



## Triumph TR7 Workshop and Maintenance Manual

# SAVE £28,000 TODAY.



The TR7 does 113 mph.  
Is shaped like a knife.

Has headlights which  
pop out of the bonnet at the  
flick of a switch.

Holds the road like glue. Has five  
gears and a faster overtaking acceleration  
than a Saab Turbo.\*\*

Does 37.9 miles per gallon at 56 mph  
- if you can get it to go that slow. Comes  
as Fixed Head or Drophead. Attracts  
envious glances. And costs from £6,137.

At £35,100, the Ferrari 512 B.B. is, we  
admit, even faster, ritzier and flashier.

But let's face it, in these hard times, you've  
got to economise somewhere.

**TR7. The exciting car you can afford.**



\*OFFICIAL UK CITY FUEL CONSUMPTION FIGURES (TR7) OPERATED UNDER DRIVING CONDITIONS: CITY 12.1 L/100KM AT 50 MPH DRIVING 12.7 L/100KM AT 70 MPH DRIVING 12.7 L/100KM AT 90 MPH DRIVING 12.7 L/100KM. THESE FIGURES ARE FOR YOUR OWN DRIVING. \*\*SAAB TURBO SEPT 82 TO SEP 83 110 MPH TR7 IN 11.2 SECS. SAAB TURBO SEPT 82 IN 10.2 SECS. PRICE GIVEN AT TIME OF QUOTE TO INCLUDE FRONT SEAT BELTS, CATALYTIC CONVERTER AND DELIVERY AND NUMBER PLATE (EXTRA). WHEELS, CRUISE CONTROL AND OPTIONAL EXTRA ALLOY WHEELS ARE STANDARD WITH THE TR7. FIXED HEADLAMP AND OPTIONAL EXTRA WITH THE TR7 DROPHEAD.



The TR7 Drophead – Quick, before it's too late.

Further information from  BLESO, Av. du Parc de Woluwé 50, 1160 Brussels.



# CONTENTS

	<b>Section</b>	<b>Page</b>
General Specification Data . . . . .	04	1
Engine Tuning Data . . . . .	05	7
Torque Wrench Settings . . . . .	06	8
Lubricants and Anti-Freeze Solutions . . . . .	09	12
Fault Finding, Diagnosis, Maintenance . . . . .	10	16
Engine -- 2 valve . . . . .	12	39
4 valve . . . . .	12	89
Emission Control . . . . .	17	126
Fuel System -- UK & Europe . . . . .	19	143
USA & Canada . . . . .	19	154
Cooling System . . . . .	26	167
Manifold & Exhaust System . . . . .	30	174
Clutch . . . . .	33	176
Gearbox -- 4 Speed . . . . .	37	179
5 Speed . . . . .	37	193
Automatic . . . . .	44	203
Propeller & Drive Shafts . . . . .	47	230
Rear Axle -- 4 Speed . . . . .	51	231
5 Speed . . . . .	51	238
Steering . . . . .	57	244
Front Suspension . . . . .	60	250
Rear Suspension . . . . .	64	255
Brakes . . . . .	70	258
Body . . . . .	76	270
Heating & Ventilation . . . . .	80	291
Air Conditioning . . . . .	82	294
Windscreen Wipers & Washers . . . . .	84	332
Electrical System . . . . .	86	340
Instruments . . . . .	88	392
Service Tools . . . . .	99	399
Index . . . . .		407

## INTRODUCTION

The purpose of this manual is to assist skilled mechanics in the efficient repair and maintenance of Triumph TR7 vehicles. Using the appropriate service tools and carrying out the procedures as detailed will enable the operations to be completed in the time stated in the 'Repair Operations Times'.

### Indexing

The contents page lists the titles and reference numbers of the divisions in numerical order.

A complete index of operations, together with their page numbers, is given in the introductory pages of this manual.

### Operation Numbering

A master index of numbered operations has been compiled for universal application to all vehicles manufactured by the British Leyland Motor Corporation and, therefore, because of the different specifications of various models, continuity of the numbering sequence cannot be maintained throughout this manual.

Each operation described in this manual is allocated a number from the master index and cross-refers with an identical number in the 'Repair Operations Times'. The number consists of six digits arranged in three pairs.

Each instruction within an operation has a sequence number and, to complete the operation in the minimum time, it is essential that the instructions are performed in numerical sequence commencing at 1 unless otherwise stated. Where applicable, the sequence numbers identify the relevant components in the appropriate illustration.

### Service Tools

Where performance of an operation requires the use of a service tool, the tool number is quoted under the operation heading and is repeated in, or following, the instruction involving its use. An illustrated list of all necessary tools is included in 'SERVICE TOOLS'.

### References

References to the left- or right-hand side in the manual are made when viewing from the rear. With the engine and gearbox assembly removed, the 'timing cover' end of the engine is referred to as the front. A key to abbreviations and symbols is given on page v.

Where the specification of the vehicle is varied, the operation will detail which variant is concerned, i.e. 4 valve for Sprint TR7's or USA and Canada for full emission vehicles. The engine, axle, fuel system and gearbox sections have alternative footlines to cater for the major variations, i.e. 2 and 4 valves; 4 and 5 speed gearbox; and the axle is similarly termed 4 and 5 speed to denote with which gearbox the axle is fitted.

## REPAIRS AND REPLACEMENTS

When service parts are required it is essential that only genuine Triumph or British Leyland Unipart replacements are used.

Attention is particularly drawn to the following points concerning repairs and the fitting of replacement parts and accessories.

Safety features embodied in the car may be impaired if other than genuine parts are fitted. In certain territories, legislation prohibits the fitting of parts not to the vehicle manufacturer's specification. Torque wrench setting figures given in the Repair Operation Manual must be strictly adhered to. Locking devices, where specified, must be fitted. If the efficiency of a locking device is impaired during removal it must be renewed. Owners purchasing accessories while travelling abroad should ensure that the accessory and its fitted location on the car conform to mandatory requirements in their country of origin.

The car warranty may be invalidated by the fitting of other than genuine British Leyland parts. All British Leyland Unipart replacements have the full backing of the factory warranty.

British Leyland Distributors and Dealers are obliged to supply only genuine service parts.



## ABBREVIATIONS AND SYMBOLS

Across flats (bolt size)	A.F.	Miles per gallon	m.p.g.
After bottom dead centre	A.B.D.C.	Miles per hour	m.p.h.
After top dead centre	A.T.D.C.	Millimetres	mm
Alternating current	a.c.	Millimetres of mercury	mmHg
Amperes	amp	Minimum	min.
Ampere-hour	Ah	Minus (of tolerance)	-
Atmospheres	Atm	Minute (of angle)	'
Before bottom dead centre	B.B.D.C.	Negative (electrical)	-
Before top dead centre	B.T.D.C.	Newton Metres	Nm
Bottom dead centre	B.D.C.	Number	No.
Brake horse-power	b.h.p.	Ohms	ohm
Brake mean effective pressure	b.m.e.p.	Ounces (force)	ozf
British Standards	B.S.	Ounces (mass)	oz
Carbon monoxide	CO	Ounce inch (torque)	ozf in
Centigrade (Celsius)	C	Outside diameter	o.dia.
Centimetres	cm	Overdrive	O/D
Cubic centimetres	cm <sup>3</sup>	Paragraphs	para.
Cubic inches	in <sup>3</sup>	Part Number	Part No.
Cycles per minute	c/min	Percentage	%
Degree (angle)	deg. or °	Pints (Imperial)	pt
Degree (temperature)	deg. or °	Pints (U.S.)	U.S. pt
Diameter	dia.	Plus or minus	±
Direct current	d.c.	Plus (tolerance)	+
Fahrenheit	F	Positive (electrical)	+
Feet	ft	Pounds (force)	lbf
Feet per minute	ft/min	Pounds (mass)	lb
Fifth	5th	Pounds feet (torque)	lbf ft
Fig. (illustration)	Fig.	Pounds inches (torque)	lbf in
First	1st	Pounds per square inch	lb/in <sup>2</sup>
Fourth	4th	Radius	r
Gallons (Imperial)	gal.	Ratio	:
Gallons (U.S.)	U.S. gal	Reference	ref.
Grammes (force)	gf	Revolutions per minute	rev/min
Grammes (mass)	g	Right-hand	R.H.
High compression	h.c.	Right-hand steering	R.H.Stg.
High tension (electrical)	h.t.	Second (angle)	"
Horse-power	hp	Second (numerical order)	2nd
Hundredweight	cwt	Single carburetter	SC
Inches	in	Society of Automobile Engineers	S.A.E.
Inches of mercury	inHg	Specific gravity	sp. gr.
Independent front suspension	i.f.s.	Square centimetres	cm <sup>2</sup>
Internal diameter	i.dia.	Square inches	in <sup>2</sup>
Kilogrammes (force)	kgf	Standard	std.
Kilogrammes (mass)	kg	Standard wire gauge	s.w.g.
Kilogramme centimetre	kgf cm	Synchronizer/synchromesh	synchro
Kilogramme metres	kgf m	Third	3rd
Kilogrammes per square centimetre	kg/cm <sup>2</sup>	Twin carburetters	TC
Kilometres	km	United Kingdom	UK
Kilometres per hour	km/h	Volts	V
Kilovolts	kV	Watts	W
King pin inclination	k.p.i.	Screw threads	
Left-hand	L.H.	American Standard Taper	
Left-hand steering	L.H. Stg.	Pipe	N.P.T.F.
Left-hand thread	L.H. Thd.	British Association	B.A.
Low compression	l.c.	British Standard Fine	B.S.F.
Low tension	l.t.	British Standard Pipe	B.S.P.
Maximum	max.	British Standard Whitworth	B.S.W.
Metres	m	Unified Coarse	U.N.C.
Microfarad	mfd	Unified Fine	U.N.F.
Miniature Edison Screw	MES		

# INDEX

	Section	Page
Introduction . . . . .	04	iv
Abbreviations and Symbols . . . . .	01	v
General Specification Data . . . . .	04	v
Engine Tuning Data . . . . .	05	1
Torque Wrench Settings . . . . .	06	8
Lubricants and Anti-Freeze Solutions . . . . .	09	12
Maintenance – UK & Europe . . . . .	10	16
Fault Finding Diagnosis – USA & Canada . . . . .	10	26
Maintenance – USA & Canada . . . . .	10	31
<b>ENGINE – 2 VALVE</b>		
	<b>Operation</b>	<b>Page</b>
	<b>No.</b>	<b>No.</b>
Alternator carrier bracket – remove and refit . . . . .	12.25.21	52
Camshaft – remove and refit . . . . .	12.13.01	42
Camshaft cover – remove and refit . . . . .	12.29.42	58
Connecting rod bearings		
– extra each – remove and refit . . . . .	12.17.18	46
– one – remove and refit . . . . .	12.17.17	46
– remove and refit . . . . .	12.17.16	46
Connecting rod and pistons		
– overhaul . . . . .	12.17.10	44
– set – remove and refit . . . . .	12.17.01	43
Crankshaft – remove and refit . . . . .	12.21.33	49
Crankshaft end-float – check and adjust . . . . .	12.21.26	48
Crankshaft pulley – remove and refit . . . . .	12.21.01	46
Crankshaft pulley and auxiliary drives – remove and refit . . . . .	12.21.02	47
Crankshaft rear oil seal – remove and refit . . . . .	12.21.20	47
Cylinder block drain plug – remove and refit . . . . .	12.25.07	51
Cylinder head		
– overhaul . . . . .	12.29.18	56
– remove and refit . . . . .	12.29.10	56
Cylinder head gasket		
– UK & Europe – remove and refit . . . . .	12.29.02	52
– USA & Canada – remove and refit . . . . .	12.29.02	54
Cylinder head nuts – tighten . . . . .	12.29.27	58
Engine assembly		
– UK & Europe – strip and rebuild . . . . .	12.41.05	63
– USA & Canada – strip and rebuild . . . . .	12.41.05	68
Engine and gearbox assembly – remove and refit . . . . .	12.37.01	60
Engine mounting		
– front L.H. – remove and refit . . . . .	12.45.01	74
– front R.H. – remove and refit . . . . .	12.45.03	74
– rear centre – remove and refit . . . . .	12.45.08	75
Engine rear adaptor plate – remove and refit . . . . .	12.53.03	76
Engine stabilizer – remove and refit . . . . .	12.45.16	75
Exhaust valve seat – remove and refit . . . . .	12.29.77	55
Flywheel – remove and refit . . . . .	12.53.07	76
Gudgeon pin bush – each – remove and refit . . . . .	12.17.13	45
Inlet valve seat – remove and refit . . . . .	12.29.76	56
Jackshaft – remove and refit . . . . .	12.10.14	41

	Operation No.	Page No.
<b>Main bearings</b>		
– each – remove and refit . . . . .	12.21.40	50
– set – remove and refit . . . . .	12.21.39	50
<b>Oil filter element</b>		
– overhaul . . . . .	12.60.08	77
– remove and refit . . . . .	12.60.02	77
<b>Oil pick-up strainer – remove and refit . . . . .</b>	12.60.20	77
<b>Oil pressure relief valve – remove and refit . . . . .</b>	12.60.56	81
<b>Oil pump</b>		
– overhaul . . . . .	12.60.32	79
– remove and refit . . . . .	12.60.26	78
<b>Oil sump – remove and refit . . . . .</b>	12.60.44	79
<b>Oil transfer housing – remove and refit . . . . .</b>	12.60.14	78
<b>Spigot bush – remove and refit . . . . .</b>	12.21.45	51
<b>Starter ring gear – remove and refit . . . . .</b>	12.53.19	77
<b>Tappets – remove and refit . . . . .</b>	12.29.57	59
<b>Timing chain – remove and refit . . . . .</b>	12.65.14	86
<b>Timing chain cover</b>		
– UK & Europe – remove and refit . . . . .	12.65.01	81
– USA & Canada – remove and refit . . . . .	12.65.01	82
<b>Timing chain guides – remove and refit . . . . .</b>	12.65.50	88
<b>Timing chain and sprockets – remove and refit . . . . .</b>	12.65.12	85
<b>Timing chain sprockets – remove and refit . . . . .</b>	12.65.22	87
<b>Timing chain tensioner – remove and refit . . . . .</b>	12.65.28	77
<b>Timing cover oil seal – remove and refit . . . . .</b>	12.65.05	83
<b>Valve clearance – check and adjust . . . . .</b>	12.29.48	58
<b>Valve timing</b>		
– UK & Europe – check and adjust . . . . .	12.65.08	83
– USA and Canada – check and adjust . . . . .	12.65.08	84
<b>Valves</b>		
– exhaust – remove and refit . . . . .	12.29.60	56
– inlet and exhaust – remove and refit . . . . .	12.29.62	56
– inlet – remove and refit . . . . .	12.29.63	56
<b>Valve guide</b>		
– exhaust – remove and refit . . . . .	12.29.71	56
– inlet – remove and refit . . . . .	12.29.70	56
<b>Water transfer housing – remove and refit . . . . .</b>	12.29.04	56
<b>ENGINE – 4 VALVE</b>		
<b>Camshaft – remove and refit . . . . .</b>	12.13.02	90
<b>Camshaft cover – remove and refit . . . . .</b>	12.29.42	104
<b>Connecting rod bearings – remove and refit . . . . .</b>	12.17.16	95
<b>Connecting rods and pistons</b>		
– overhaul . . . . .	12.17.10	92
– set – remove and refit . . . . .	12.17.01	91
<b>Crankshaft – remove and refit . . . . .</b>	12.21.33	96
<b>Crankshaft end-float – check and adjust . . . . .</b>	12.21.26	95
<b>Crankshaft pulley – remove and refit . . . . .</b>	12.21.01	94
<b>Crankshaft rear oil seal – remove and refit . . . . .</b>	12.21.20	95
<b>Cylinder block drain plug – remove and refit . . . . .</b>	12.25.07	99



**ENGINE — 4 VALVE — continued**

	Operation No.	Page No.
Cylinder head		
— overhaul . . . . .	12.29.19	101
— remove and refit . . . . .	12.29.11	99
Cylinder head gasket — remove and refit . . . . .	12.29.02	99
Cylinder head nuts — tighten . . . . .	12.29.27	105
Engine assembly — strip and rebuild . . . . .	12.41.05	108
Engine and gearbox assembly — remove and refit . . . . .	12.37.01	107
Engine mountings		
— front L.H. — remove and refit . . . . .	12.45.01	115
— front R.H. — remove and refit . . . . .	12.45.03	115
— rear centre — remove and refit . . . . .	12.45.08	116
Engine rear adaptor plate — remove and refit . . . . .	12.53.03	116
Exhaust valve seat — remove and refit . . . . .	12.29.77	101
Flywheel — remove and refit . . . . .	12.53.07	117
Gudgeon pin bush — each — remove and refit . . . . .	12.17.13	92
Inlet valve seat — remove and refit . . . . .	12.29.76	101
Jackshaft — remove and refit . . . . .	12.10.14	89
Main bearings		
— set — remove and refit . . . . .	12.21.39	98
Oil filter assembly — remove and refit . . . . .	12.60.02	107
Oil filter assembly — overhaul . . . . .	12.60.08	107
Oil transfer housing — remove and refit . . . . .	12.60.14	118
Oil pick-up strainer — remove and refit . . . . .	12.60.20	118
Oil pressure relief valve — remove and refit . . . . .	12.60.56	120
Oil pump		
— overhaul . . . . .	12.60.23	119
— remove and refit . . . . .	12.60.26	118
Oil sump — remove and refit . . . . .	12.60.44	120
Piston assembly — set — remove and refit . . . . .	12.17.03	92
Rocker shaft assembly		
— overhaul . . . . .	12.29.55	106
— remove and refit . . . . .	12.29.54	106
Spark plug tubes — remove and refit . . . . .	12.29.81	107
Spigot bush — remove and refit . . . . .	12.21.45	99
Starter ring gear — remove and refit . . . . .	12.53.19	117
Tappets — remove and refit . . . . .	12.29.57	117
Timing chain — remove and refit . . . . .	12.65.14	122
Timing chain cover — remove and refit . . . . .	12.65.01	121
Timing chain guides — remove and refit . . . . .	12.65.50	122
Timing chain and sprockets — remove and refit . . . . .	12.65.12	122
Timing chain tensioner — remove and refit . . . . .	12.65.28	124
Timing cover oil seal — remove and refit . . . . .	12.65.05	121
Valve clearance — check and adjust . . . . .	12.29.48	104
Valve timing — check and adjust . . . . .	12.65.08	121
Valves		
— exhaust — remove and refit . . . . .	12.29.64	101
— inlet and exhaust — remove and refit . . . . .	12.29.62	101
— inlet — remove and refit . . . . .	12.29.63	101

	Operation No.	Page No.
Valve guides		
– exhaust – remove and refit . . . . .	12.29.71	101
– inlet – remove and refit . . . . .	12.29.70	101
<b>EMISSION AND EVAPORATIVE LOSS CONTROL</b>		
Adsorption canister – remove and refit . . . . .	17.15.13	135
Air distribution manifold – remove and refit . . . . .	17.25.17	137
Air intake temperature control		
– description . . . . .	17.30.00	139
– fault finding . . . . .	17.30.01	140
– function test . . . . .	17.30.01	139
Air pump		
– drive belt – remove and refit . . . . .	17.25.15	137
– drive belt tensioning . . . . .	17.25.13	137
– remove and refit . . . . .	17.25.07	136
Catalytic converter – remove and refit . . . . .	17.50.01	142
Check valve		
– remove and refit . . . . .	17.25.21	137
– test . . . . .	17.25.22	138
Description		
– crankcase emission control . . . . .	17.00.04	126
– evaporative loss control . . . . .	17.00.05	129
– exhaust emission control . . . . .	17.00.08	132
Diverter and relief valve – remove and refit . . . . .	17.25.25	138
E.G.R. control valve – remove and refit . . . . .	17.45.05	142
E.G.R. valve – remove and refit . . . . .	17.45.01	141
One-way valve – remove and refit . . . . .	17.30.05	141
Running-on control valve . . . . .	17.40.01	141
Temperature sensor unit – remove and refit . . . . .	17.30.10	141
Vapour separator – remove and refit . . . . .	17.15.02	135
<b>FUEL SYSTEM – UK &amp; EUROPE</b>		
Air cleaner		
– remove and refit . . . . .	19.10.01	143
– renew element . . . . .	19.10.08	143
Carburettors		
– flexible mountings – remove and refit . . . . .	19.15.19	149
– float chamber needle and seat – remove and refit . . . . .	19.15.24	149
– overhaul . . . . .	19.15.17	147
– piston and suction chamber – remove and refit . . . . .	19.15.30	149
– remove and refit . . . . .	19.15.11	146
– tune and adjust . . . . .	19.15.02	144
Fuel pump		
– clean filter . . . . .	19.45.05	152
– remove and refit . . . . .	19.45.08	152
Fuel tank – remove and refit . . . . .	19.55.01	152
Fuel filler cap assembly – remove and refit . . . . .	19.55.08	153
Fuel pipe main line		
– engine end section – remove and refit . . . . .	19.40.04	151
– tank end section – remove and refit . . . . .	19.40.02	151
Hose – filler to tank – remove and refit . . . . .	19.40.19	152
Mixture control cable assembly		
– remove and refit . . . . .	19.20.13	151
– inner cable – remove and refit . . . . .	19.20.14	151
Throttle pedal – remove and refit . . . . .	19.20.01	150

## FUEL SYSTEM – USA & CANADA

	Operation No.	Page No.
Air cleaner		
– remove and refit . . . . .	19.10.01	154
– renew element . . . . .	19.10.08	154
Automatic choke (F.A.S.D.) – remove and refit . . . . .	19.15.38	161
Carburettor		
– complete with inlet manifold – remove and refit . . . . .	19.15.15	159
– deceleration and by-pass valve (twin carburettor)		
– remove and refit . . . . .	19.15.64	161
– diaphragm – remove and refit . . . . .	19.15.35	160
– float-chamber level – check and adjust . . . . .	19.15.32	160
– float-chamber needle valve – remove and refit . . . . .	19.15.24	160
– remove and refit . . . . .	19.15.11	158
– rubber mountings – set – remove and refit . . . . .	19.15.19	160
– starter assembly – remove and refit . . . . .	19.15.52	161
– temperature compensator – remove and refit . . . . .	19.15.59	161
– tune and adjust . . . . .	19.15.02	155
Fuel filler cap and filler assembly – remove and refit . . . . .	19.55.08	166
Fuel pump		
– clean filter . . . . .	19.45.05	165
– remove and refit . . . . .	19.45.08	165
Fuel tank – remove and refit . . . . .	19.55.01	164
Hose – filler to tank – remove and refit . . . . .	19.40.19	163
Petrol pipe		
– engine end section – remove and refit . . . . .	19.40.04	163
– main line – tank end section – remove and refit . . . . .	19.40.02	162
Throttle pedal – remove and refit . . . . .	19.20.01	162

## COOLING SYSTEM

Coolant – drain and refill . . . . .	26.10.01	167
Connecting tube . . . . .	26.30.25	170
Expansion tank – remove and refit . . . . .	26.15.01	167
Fan belt – remove and refit . . . . .	26.20.07	167
Fan blades – remove and refit . . . . .	26.25.06	168
Fan pulley and blade assembly – remove and refit . . . . .	26.25.21	169
Radiator assembly – remove and refit . . . . .	26.40.01	170
Radiator bottom hose – remove and refit . . . . .	26.30.07	170
Radiator top hoses – remove and refit . . . . .	26.30.01	169
Thermostat		
– remove and refit . . . . .	26.45.01	171
– test . . . . .	26.45.10	171
Viscous coupling – remove and refit . . . . .	26.25.19	168
Water pump		
– overhaul . . . . .	26.50.06	172
– remove and refit . . . . .	26.50.01	171

## MANIFOLD AND EXHAUST SYSTEM

Catalytic converter . . . . .	refer to 17.50.01	142
Exhaust front pipe – remove and refit . . . . .	30.10.09	174
Exhaust front pipe gasket – remove and refit . . . . .	30.10.26	174
Exhaust manifold		
– remove and refit – UK & Europe . . . . .	30.15.01	174
– remove and refit – USA & Canada . . . . .	30.15.01	175
Induction manifold – remove and refit . . . . .	30.15.02	175
Silencer – front – remove and refit . . . . .	30.10.14	174
Tail pipe and silencer – remove and refit . . . . .	30.10.22	174

<b>CLUTCH</b>	<b>Operation No.</b>	<b>Page No.</b>
Clutch assembly – remove and refit . . . . .	33.10.01	176
Clutch and brake pedal assembly		
– overhaul . . . . .	33.30.06	178
– remove and refit . . . . .	33.30.01	178
Clutch pedal return spring – remove and refit . . . . .	33.30.03	178
Drive plate – remove and refit . . . . .	33.10.02	176
Fluid pipe – remove and refit . . . . .	33.15.09	176
Hydraulic system – bleeding . . . . .	33.15.01	176
Master cylinder		
– overhaul . . . . .	33.20.07	177
– remove and refit . . . . .	33.20.01	177
Release bearing – overhaul . . . . .	33.25.17	178
Release bearing assembly – remove and refit . . . . .	33.25.12	177
Slave cylinder		
– overhaul . . . . .	33.35.07	178
– remove and refit . . . . .	33.35.01	178

### **MANUAL GEARBOX – 4 SPEED**

Clutch/bell housing – remove and refit . . . . .	37.12.07	180
Drive flange – remove and refit . . . . .	37.10.01	179
First motion shaft		
– bearing – remove and refit . . . . .	37.20.17	189
– oil seal – remove and refit . . . . .	37.23.04	191
– remove and refit . . . . .	37.20.16	189
Gear change		
– lever – remove and refit . . . . .	37.16.04	181
– lever – draught excluder – remove and refit . . . . .	37.16.05	181
– rod – oil seal – remove and refit . . . . .	37.23.10	191
– selector mechanism and housing		
– remove and refit . . . . .	37.16.37	182
– selectors – remove and refit . . . . .	37.16.31	181
Gearbox assembly		
– overhaul . . . . .	37.20.04	183
– remove and refit . . . . .	37.20.01	182
Layshaft		
– bearing – remove and refit . . . . .	37.20.22	190
– remove and refit . . . . .	37.20.19	190
Main case – remove and refit . . . . .	37.12.40	181
Mainshaft bearing – remove and refit . . . . .	37.20.26	190
Rear extension – remove and refit . . . . .	37.12.01	179
Rear oil seal – remove and refit . . . . .	37.23.01	191
Speedometer		
– drive gear – remove and refit . . . . .	37.25.01	192
– drive pinion – remove and refit . . . . .	37.25.05	192
Synchronizer assemblies – remove and refit . . . . .	37.20.07	189

### **GEARBOX – 5 SPEED**

Clutch/bell housing – remove and refit . . . . .	37.12.07	193
Drive flange – remove and refit . . . . .	37.10.01	193
First motion shaft oil seal – remove and refit . . . . .	37.23.04	201
Gear change lever – remove and refit . . . . .	37.16.04	195
Gear change remote control assembly		
– overhaul . . . . .	37.16.20	196
– remove and refit . . . . .	37.16.19	195

**GEARBOX -- 5 SPEED -- continued**

	Operation No.	Page No.
Gearbox assembly		
- overhaul . . . . .	37.20.04	198
- remove and refit . . . . .	37.20.01	197
Oil pump		
- remove and refit . . . . .	37.12.47	192
- test . . . . .	37.12.50	195
Rear cover -- remove and refit . . . . .	37.12.42	193
Speedometer drive		
- gear -- remove and refit . . . . .	37.25.01	202
- pinion -- remove and refit . . . . .	37.25.05	202

**AUTOMATIC GEARBOX**

Dipstick/filler tube -- remove and refit . . . . .	44.24.01	219
Downshift cable		
- adjust . . . . .	44.30.02	221
- initial setting . . . . .	44.30.01	221
- pressure check . . . . .	44.30.03	221
- remove and refit . . . . .	44.15.01	211
Front brake band		
- adjust . . . . .	44.30.07	221
- remove and refit . . . . .	44.10.01	205
Front clutch		
- overhaul . . . . .	44.12.10	209
- remove and refit . . . . .	44.12.04	207
Front servo		
- overhaul . . . . .	44.34.10	224
- remove and refit . . . . .	44.34.07	224
Gearbox		
- overhaul . . . . .	44.20.06	214
- remove and refit . . . . .	44.20.01	213
- selector lever -- remove and refit . . . . .	44.15.09	213
Governor		
- overhaul . . . . .	44.22.04	218
- remove and refit . . . . .	44.22.01	218
Hand selector lever		
- overhaul . . . . .	44.15.05	212
- remove and refit . . . . .	44.15.04	211
Hand selector lever turret -- overhaul . . . . .	44.15.06	212
Oil/fluid cooler -- remove and refit . . . . .	44.24.10	220
Oil/fluid filter -- remove and refit . . . . .	44.24.07	220
Output shaft -- remove and refit . . . . .	44.36.01	225
Planet gears and rear drum assembly -- remove and refit . . . . .	44.36.04	227
Pump		
- overhaul . . . . .	44.32.04	223
- remove and refit . . . . .	44.32.01	223
Rear brake band		
- adjust . . . . .	44.30.10	221
- remove and refit . . . . .	44.10.09	206
Rear clutch		
- overhaul . . . . .	44.12.13	209
- remove and refit . . . . .	44.12.07	208
Rear extension housing -- remove and refit . . . . .	44.20.15	217
Rear oil seal -- remove and renew . . . . .	44.20.18	218
Rear servo		
- overhaul . . . . .	44.34.16	224
- remove and refit . . . . .	44.34.13	224
Road test . . . . .	44.30.17	221

	Operation No.	Page No.
Selector rod		
– adjust	44.30.04	221
– remove and refit	44.15.08	212
Speedometer		
– drive gear – remove and refit	44.38.07	228
– drive pinion – remove and refit	44.38.04	228
Stall test	44.30.13	221
Starter inhibitor/reverse lamp switch – remove and refit	44.15.15	213
Torque converter		
– remove and refit	44.17.07	213
– housing – remove and refit	44.17.01	213
Transmission		
– fluid – drain and refill	44.24.02	219
– sump – remove and refit	44.24.04	219
Uni-directional clutch		
– remove and refit	44.12.16	210
Valve block		
– overhaul	44.40.04	229
– remove and refit	44.40.01	228

## PROPELLER SHAFT

Propeller shaft – remove and refit	47.15.01	230
Universal joint – remove and refit	47.15.18	230

## REAR AXLE – 4 SPEED GEARBOX

Differential assembly		
– overhaul	51.15.07	233
– pinion oil seal – remove and refit	51.20.01	235
– remove and refit	51.15.01	232
Half shaft		
– bearing and oil seal – remove and refit	51.10.02	231
– inner oil seal – remove and refit	51.20.14	236
– remove and refit	51.10.01	231
Rear axle assembly		
– casing – remove and refit	51.25.04	237
– remove and refit	51.25.01	236
Rear hub		
– oil seal – remove and refit	51.20.17	236
– remove and refit	51.10.18	232
– wheel studs – remove and refit	51.10.19	232

## REAR AXLE – 5 SPEED GEARBOX

Differential assembly – overhaul	51.15.07	239
Differential pinion oil seal – remove and refit	51.20.01	242
Half shaft assembly – remove and refit	51.10.12	238
Half shaft bearing and outer seal – remove and refit	51.10.02	238
Half shaft inner oil seal – remove and refit	51.10.14	239
Rear axle assembly – remove and refit	51.25.01	242

## STEERING

Front wheel alignment – check and adjust	57.65.01	249
Intermediate shaft – remove and refit	57.40.22	247
Nacelle – remove and refit	57.40.29	248

**STEERING — continued**

	Operation No.	Page No.
Steering-column		
— overhaul	57.40.10	247
— remove and refit	57.40.01	246
Steering geometry	57.65.00	4
Steering lock/ignition switch — remove and refit	57.40.31	248
Steering rack		
— damper — adjust	57.35.09	245
— damper — remove and refit	57.35.10	246
— gaiters — remove and refit	57.25.02	244
— rack — overhaul	57.25.07	245
— remove and refit	57.25.01	244
Steering-wheel — remove and refit	57.60.01	249
Tie-rod ball joint		
— inner — remove and refit	57.55.03	248
— outer — remove and refit	57.55.02	248
Upper universal coupling — remove and refit	57.40.26	247

**FRONT SUSPENSION**

Anti-roll bar		
— bottom link rubbers — remove and refit	60.10.06	250
— mounting rubbers — remove and refit	60.10.05	250
— remove and refit	60.10.01	250
Ball joint — bottom link — remove and refit	60.15.03	250
Bottom link		
— overhaul	60.40.06	254
— remove and refit	60.40.02	254
Bump stops — remove and refit	60.30.10	251
Dampers — remove and refit	60.30.02	253
Hub		
— bearing end-float — check and adjust	60.25.13	252
— bearings — remove and refit	60.25.14	252
— oil seal — remove and refit	60.25.15	253
— remove and refit	60.25.01	252
Road spring — remove and refit	60.20.01	251
Stub axle assembly — remove and refit	60.25.22	253
Upper swivel — remove and refit	60.30.04	253
Wheel studs — remove and refit	60.25.29	253

**REAR SUSPENSION**

Anti-roll bar — remove and refit	64.35.08	257
Bump stop — remove and refit	64.30.15	256
Radius rod		
— bushes — remove and refit	64.35.29	257
— remove and refit	64.35.28	257
Rear damper		
— remove and refit — L.H.	64.30.02	255
— remove and refit — R.H.	64.30.03	256
Road spring		
— insulating ring — remove and refit	64.20.17	255
— remove and refit	64.20.01	255
Suspension arm		
— bushes — remove and refit	64.35.05	257
— remove and refit	64.35.02	256

## BRAKES

	Operation No.	Page No.
Brake hose		
- front L.H. - remove and refit . . . . .	70.15.02	259
- front R.H. - remove and refit . . . . .	70.15.03	259
- rear - remove and refit . . . . .	70.15.17	259
Brakes		
- adjust . . . . .	70.25.03	261
- bleed . . . . .	70.25.02	261
Disc shield - remove and refit . . . . .	70.10.18	259
Front brake - disc		
- caliper - remove and refit . . . . .	70.55.02	267
- caliper seals - remove and refit . . . . .	70.55.13	268
- disc - remove and refit . . . . .	70.10.10	258
- pads - remove and refit . . . . .	70.40.02	264
Handbrake		
- cable - remove and refit . . . . .	70.35.16	264
- cables - adjust . . . . .	70.35.10	263
- lever assembly - remove and refit . . . . .	70.35.08	263
Hydraulic pipes . . . . .	70.20.00	260
Master cylinder - tandem		
- overhaul . . . . .	70.30.09	262
- remove and refit . . . . .	70.30.08	262
Pedal box		
- overhaul . . . . .	70.35.04	263
- remove and refit . . . . .	70.35.03	263
Pressure reducing valve . . . . .	70.00.00	258
- remove and refit . . . . .	70.25.21	261
Rear brake		
- backplate - remove and refit . . . . .	70.10.26	259
- drum - remove and refit . . . . .	70.10.03	258
- shoes - remove and refit . . . . .	70.40.03	265
- wheel cylinder - overhaul . . . . .	70.60.26	269
- wheel cylinder - remove and refit . . . . .	70.60.18	268
Servo		
- non-return - remove and refit . . . . .	70.50.15	265
- remove and refit . . . . .	70.50.01	266
- renewing filter . . . . .	70.50.25	267
- vacuum hose - remove and refit . . . . .	70.50.14	266

## BODY

Ashtray - remove and refit . . . . .	76.67.13	287
Air vent grille - remove and refit . . . . .	76.55.17	284
Body unit - alignment check . . . . .	76.10.01	270
Bonnet - remove and refit . . . . .	76.16.01	276
Bonnet catch		
- adjust . . . . .	76.16.20	276
- remove and refit . . . . .	76.16.34	277
Bonnet lock - remove and refit . . . . .	76.16.21	277
Bonnet release cable - remove and refit . . . . .	76.16.29	277
Bonnet stay - remove and refit . . . . .	76.16.14	276
Bumper - front - remove and refit . . . . .	76.22.08	278
Bumper - rear - remove and refit . . . . .	76.22.15	278
Carpet - floor - rear - remove and refit . . . . .	76.49.03	283



**BODY -- continued**

	<b>Operation No.</b>	<b>Page No.</b>
Carpet -- transmission tunnel -- remove and refit . . . . .	76.49.06	283
Console assembly -- remove and refit . . . . .	76.25.01	278
Control cowl -- remove and refit . . . . .	76.25.03	279
Door -- remove and refit . . . . .	76.28.01	279
Door arm-rest -- remove and refit . . . . .	76.34.23	280
Door glass -- remove and refit . . . . .	76.31.01	279
Door glass regulator -- remove and refit . . . . .	76.31.45	279
Door outside handle -- remove and refit . . . . .	76.58.01	284
Door lock -- remove and refit . . . . .	76.37.12	280
Door lock remote control -- remove and refit . . . . .	76.37.31	280
Door lock striker		
-- adjust . . . . .	76.37.27	280
-- remove and refit . . . . .	76.37.23	280
Door private lock -- remove and refit . . . . .	76.37.39	281
Door quarter-light -- remove and refit . . . . .	76.31.29	279
Door trim pad -- remove and refit . . . . .	76.34.01	280
Fascia -- remove and refit . . . . .	76.46.01	281
Fascia glovebox cowl -- remove and refit . . . . .	76.46.18	283
Fascia instrument cowl -- remove and refit . . . . .	76.46.17	282
Glovebox lid assembly -- remove and refit . . . . .	76.52.02	283
Glovebox lock -- remove and refit . . . . .	76.52.08	284
Grille -- fascia centre -- remove and refit . . . . .	76.55.14	284
Grille -- front -- remove and refit . . . . .	76.55.03	284
Headlining -- remove and refit . . . . .	76.64.01	286
Heated back-light -- remove and refit . . . . .	76.81.11	290
Hood (USA only) -- remove and refit . . . . .	76.60.01	285
Luggage compartment lid -- remove and refit . . . . .	76.19.01	277
Luggage compartment lid hinges -- remove and refit . . . . .	76.19.07	277
Luggage compartment lock -- remove and refit . . . . .	76.19.11	277
Luggage compartment lock striker -- remove and refit . . . . .	76.19.12	278
Parcel tray -- rear -- remove and refit . . . . .	76.67.06	287
Rear compartment trim pad -- remove and refit . . . . .	76.13.20	276
Rear quarter trim pad -- remove and refit . . . . .	76.13.12	276
Seat belt -- automatic -- remove and refit . . . . .	76.73.10	288
Seat -- driver -- remove and refit . . . . .	76.70.04	287
Seat -- passenger -- remove and refit . . . . .	76.70.05	287
Seat runners -- remove and refit . . . . .	76.70.21	287
Sliding roof -- remove and refit . . . . .	76.82.01	290
Sub frame -- alignment check . . . . .	76.10.04	275
Sub frame -- remove and refit . . . . .	76.10.29	275
Windscreen finisher -- lower -- remove and refit . . . . .	76.43.41	281
Windscreen -- introduction . . . . .	76.81.00	288
Windscreen -- glass -- remove and refit . . . . .	76.81.01	288

## HEATING AND VENTILATION

	Operation No.	Page No.
Air hoses		
– remove and refit – L.H.	80.15.12	291
– remove and refit – R.H.	80.15.11	291
Demister		
– ducts – remove and refit		
– passenger's side	80.15.03	291
– driver's side	80.15.08	291
Fan motor – remove and refit	80.20.15	293
Fresh air duct – remove and refit	80.15.31	292
Heater matrix – remove and refit	80.20.29	293
Heater unit – remove and refit	80.20.01	292
Swivelling vents		
– centre – remove and refit	80.15.24	292
– outer – remove and refit – L.H.	80.15.22	291
– outer – remove and refit – R.H.	80.15.23	291
Water hoses		
– feed – engine to heater		
– remove and refit	80.25.07	293
– return – heater to engine return pipe – remove and refit	80.25.12	293

## AIR CONDITIONING

Air conditioner unit		
– cold thermostat – remove and refit	82.20.18	310
– description	82.25.00	314
– expansion valve – remove and refit	82.25.01	316
– hot thermostat – remove and refit	82.20.31	312
– linkages – adjust	82.25.08	317
Cold temperature system		
– cold refrigeration circuit	82.00.00	295
– cold temperature control system	82.20.00	305
– refrigerant	82.30.00	327
Compressor		
– clutch – remove and refit	82.10.08	298
– data	82.10.00	296
– drive belt – adjust	82.10.01	297
– drive belt – remove and refit	82.10.02	297
– remove and refit	82.10.20	299
– service valves	82.30.00	321
Condenser		
– condenser and fan assembly – remove and refit	82.15.10	302
– fan motor – remove and refit	82.15.01	301
– overhaul	82.15.02	301
– remove and refit	82.15.07	302
Controls		
– cold thermostat – remove and refit	82.20.18	310
– description – cold temperature control system	82.20.00	304
– control levers	82.20.00	305
– hot temperature control system	82.20.00	305
– summary	82.20.00	305
– expansion valve – remove and refit	82.25.01	316
– high pressure cut-out – description	82.20.00	307
– remove and refit	82.20.20	311
– hot thermostat – remove and refit	82.20.31	312
– radiator switch – description	82.20.00	307
– remove and refit	82.20.09	309
– throttle jack – adjust	82.20.37	313
– description	82.20.00	307
– remove and refit	82.20.36	313
Electrical circuit		
– delay circuit flasher unit – remove and refit	refer to 86.55.31	378
– delay circuit relay – remove and refit	refer to 86.55.30	378
– description – delay circuit	82.20.00	306
– power circuit	82.20.00	306
– relay control circuit	82.20.00	306
– wiring diagram	82.20.00	306
Hot temperature system		
– hot temperature control system	82.20.00	305
– hot water circuit	82.20.00	294

**ELECTRICAL SYSTEM – continued**

	Operation No.	Page No.
Introduction . . . . .	82.00.00	294
Receiver drier – remove and refit . . . . .	82.17.01	303
<b>Servicing</b>		
– charge – complete system . . . . .	82.30.08	325
– charge – compressor only . . . . .	82.30.23	330
– data . . . . .	82.30.00	319
– description . . . . .	82.30.00	320
– discharge – complete system . . . . .	82.30.05	324
– compressor only . . . . .	82.30.20	329
– evacuate – complete system . . . . .	82.30.06	325
– compressor only . . . . .	82.30.21	329
– functional check . . . . .	82.30.16	328
– gauge set – connect . . . . .	82.30.01	323
– disconnect . . . . .	82.30.01	324
– leak test . . . . .	82.30.09	327
– service valves – positions . . . . .	82.30.00	322

**WINDSCREEN WIPERS AND WASHERS**

<b>Windscreen washer system</b>		
– jet – remove and refit . . . . .	84.10.09	333
– pump – overhaul . . . . .	84.10.24	333
– pump – remove and refit . . . . .	84.10.21	333
– reservoir – remove and refit . . . . .	84.10.01	333
– switch – remove and refit . . . . .	refer to 86.65.64	389
<b>Windscreen wiper system</b>		
– data . . . . .	84.15.00	332
– description . . . . .	84.15.00	332
– motor – overhaul . . . . .	84.15.18	337
– motor – remove and refit . . . . .	84.15.12	336
– motor and drive assembly – remove and refit . . . . .	84.15.10	335
– rack – remove and refit . . . . .	84.15.24	338
– switch – remove and refit . . . . .	refer to 86.65.64	389
– wheelbox – driver’s – remove and refit . . . . .	84.15.28	339
– wheelbox – passenger’s – remove and refit . . . . .	84.15.29	339
– wiper arm – driver’s – remove and refit . . . . .	84.15.02	335
– wiper arm – passenger’s – remove and refit . . . . .	84.15.03	334
– wiper blade – driver’s – remove and refit . . . . .	84.15.06	334
– wiper blade – passenger’s – remove and refit . . . . .	84.15.07	334

**ELECTRICAL SYSTEM**

<b>Air conditioning – electrical circuit</b>		
– air conditioning delay circuit flasher unit – remove and refit . . . . .	86.35.31	378
– air conditioning delay circuit relay – remove and refit . . . . .	86.55.30	378
<b>Alternator</b>		
– data . . . . .	86.10.00	345
– drive belt – adjust . . . . .	86.10.05	346
– overhaul . . . . .	86.10.08	348
– remove and refit . . . . .	86.10.02	345
<b>Battery – remove and refit . . . . .</b>	86.15.01	347
<b>Bulb chart . . . . .</b>	86.00.00	344
<b>Cigarette lighter – remove and refit . . . . .</b>	86.65.60	344
<b>Flasher units</b>		
– hazard flasher unit – remove and refit . . . . .	86.55.12	377
– turn signal flasher unit – remove and refit . . . . .	86.55.11	377
<b>Fuse system – fuse – remove and refit . . . . .</b>	86.70.02	391
<b>Headlamp</b>		
– actuator – overhaul . . . . .	86.40.14	367
– actuator – remove and refit . . . . .	86.40.13	367
– assembly – adjust . . . . .	86.40.16	371
– assembly – overhaul . . . . .	86.40.15	369
– assembly – remove and refit . . . . .	86.40.02	366
– beam aiming . . . . .	86.40.17	372
– circuit breaker – remove and refit . . . . .	86.40.19	372
– data . . . . .	86.40.00	365
– description . . . . .	86.40.00	365

	Operation No.	Page No.
– flash control unit – remove and refit . . . . .	86.55.38	378
– flash relay – remove and refit . . . . .	86.55.37	378
– light unit – remove and refit . . . . .	86.40.09	366
– link rod – remove and refit . . . . .	86.40.12	366
– rubber bezel – remove and refit . . . . .	86.40.01	366
– run/stop relay – remove and refit . . . . .	86.55.20	377
<b>Ignition coil and ballast resistor</b>		
– data . . . . .	86.35.00	364
– description . . . . .	86.35.00	364
– ignition coil – remove and refit . . . . .	86.35.32	364
<b>Ignition distributor</b>		
– contact assembly – remove and refit . . . . .	86.35.13	355
– contact gap – adjust . . . . .	86.35.14	355
– data . . . . .	86.35.00	352
– description . . . . .	86.35.00	350
– drive resistor – data . . . . .	86.35.00	350
– drive resistor – description . . . . .	86.35.00	350
– drive resistor – remove and refit . . . . .	86.35.37	364
– ignition timing – adjust . . . . .	86.35.15	356
– lubrication . . . . .	86.35.18	358
– overhaul . . . . .	86.35.26	360
– pick up air gap – adjust . . . . .	86.35.31	363
– remove and refit . . . . .	86.35.20	359
<b>Lamps – fascia switch panel illumination – remove and refit . . . . .</b>	<b>86.45.47</b>	<b>375</b>
– front flasher repeater lamp – remove and refit . . . . .	86.40.53	373
– front maker lamp – remove and refit . . . . .	86.40.59	373
– front parking and flasher lamp – remove and refit . . . . .	86.40.26	373
– hazard warning light – remove and refit . . . . .	86.45.76	376
– heater control illumination – remove and refit . . . . .	86.45.44	375
– instrument illumination – remove and refit . . . . .	86.45.32	375
– map/courtesy lamp – remove and refit . . . . .	86.45.10	374
– plate illumination lamp – remove and refit . . . . .	86.40.86	374
– rear lamp assembly – remove and refit . . . . .	86.40.70	374
– rear marker lamp – remove and refit . . . . .	86.40.64	373
– warning light – remove and refit . . . . .	86.45.60	376
<b>Radio</b>		
– door speaker – remove and refit . . . . .	86.50.13	376
<b>Relays</b>		
– air conditioning – control relay – remove and refit . . . . .	86.55.10	380
– headlamp – flash-relay – remove and refit . . . . .	86.55.20	381
– horn relay – remove and refit . . . . .	86.55.09	377
– starter motor relay – remove and refit . . . . .	86.55.05	376
<b>Seat belt warning system</b>		
– buzzer/timer module – remove and refit . . . . .	86.57.08	381
– fasten belts warning light – remove and refit . . . . .	86.45.60	376
<b>Spark plug – remove and refit . . . . .</b>	<b>86.35.02</b>	<b>354</b>
– remove, clean, adjust and refit . . . . .	86.35.01	354
<b>Starter motor</b>		
– data . . . . .	86.60.00	382
– remove and refit . . . . .	86.60.01	383
– roller clutch drive – remove and refit . . . . .	86.60.07	383
– overhaul . . . . .	86.60.13	384
<b>Switches</b>		
– brake line failure switch – remove and refit . . . . .	86.65.47	388
– choke switch – remove and refit . . . . .	86.65.53	389
– door switch – remove and refit . . . . .	86.65.14	386
– fascia switch panel – remove and refit . . . . .	86.65.66	391
– front fog lamp switch – remove and refit . . . . .	86.65.19	386
– hand brake switch – remove and refit . . . . .	86.65.45	388
– hazard switch – remove and refit . . . . .	86.65.50	388
– heated backlight switch – remove and refit . . . . .	86.65.36	387
– ignition/starter switch – remove and refit . . . . .	86.65.02	385
– key switch – remove and refit . . . . .	refer to 57.40.31	387
– master light switch – remove and refit . . . . .	86.65.09	386
– oil pressure switch – remove and refit . . . . .	86.65.30	387
– panel rheostat – remove and refit . . . . .	86.65.12	386
– passenger's belt switch – remove and refit . . . . .	86.65.32	387
– passenger's seat switch – remove and refit . . . . .	86.65.29	387
– rear fog lamp switch – remove and refit . . . . .	86.65.65	391
– reverse lamp switch – remove and refit . . . . .	86.65.20	386
– steering column multi-purpose switch – remove and refit . . . . .	86.65.64	389
– stop lamp switch – remove and refit . . . . .	86.65.51	388

**ELECTRICAL SYSTEM – continued**

	<b>Operation No.</b>	<b>Page No.</b>
Wiring diagram		
– UK and Europe . . . . .	86.00.01	340
– USA market . . . . .	86.00.02	342

**INSTRUMENTS**

Battery condition indicator		
– data . . . . .	88.10.00	392
– description . . . . .	88.10.00	397
– remove and refit . . . . .	88.10.07	392

Clock		
– adjust . . . . .	88.15.04	392
– data . . . . .	88.15.00	392
– remove and refit . . . . .	88.15.07	392

Fuel indication		
– data . . . . .	88.25.00	395
– description . . . . .	88.25.00	396
– fuel indicator – remove and refit . . . . .	88.25.26	397
– fuel tank unit – remove and refit . . . . .	88.25.32	397

Instrument panel		
– description . . . . .	88.20.00	393
– lens – remove and refit . . . . .	88.20.17	395
– printed circuit – remove and refit . . . . .	88.20.19	395
– remove and refit . . . . .	88.20.01	394
– warning light – remove and refit . . . . . refer to	86.45.60	376

Speedometer		
– remove and refit . . . . .	88.30.01	398
– trip reset cable – remove and refit . . . . .	88.30.02	398

Tachometer		
– remove and refit . . . . .	88.30.21	398

Temperature indication		
– data . . . . .	88.25.00	395
– description . . . . .	88.25.00	396
– temperature indicator – remove and refit . . . . .	88.25.14	397
– temperature transmitter – remove and refit . . . . .	88.25.20	397

<b>SERVICE TOOLS . . . . .</b>		<b>399</b>
--------------------------------	--	------------

## GENERAL SPECIFICATION DATA

### ENGINE

Type	In line — inclined at 40 degrees
Number of cylinders	4
Bore	3.56 in (90,3 mm)
Stroke	3.07 in (78,0 mm)
Capacity	122 in <sup>3</sup> (1998 cm <sup>3</sup> )
Valve operation	Single overhead camshaft

### Crankshaft

Main journal diameter	2.1260 to 2.1265 in (54,000 to 54,013 mm)
Minimum regrind diameter	2.0860 to 2.0865 in (52,984 to 52,997 mm)
Crankpin journal diameter	1.7500 to 1.7505 in (44,450 to 44,463 mm)
Minimum regrind diameter	1.7100 to 1.7105 in (43,434 to 43,447 mm)
Crankshaft end thrust	Taken on thrust washers at centre main bearing
Crankshaft end float	0.003 to 0.011 in (0,07 to 0,28 mm)

### Main bearings

Number	5
Diametrical clearance	0.0012 to 0.0022 in (0,030 to 0,058 mm)
Undersizes	0.010 in 0.020 in 0.030 in 0.040 in (0,254 mm 0,508 mm 0,762 mm 1,016 mm)

### Connecting rods

Small end bush fitted internal diameter	0.9377 to 0.9380 in (23,818 to 23,825 mm)
Bush external diameter	1.0015 to 1.0025 in (25,438 to 25,464 mm)
Small end diameter less bush	0.9995 to 1.0005 in (25,387 to 25,413 mm)
Big end diameter less shells	1.8955 to 1.8960 in (48,146 to 48,158 mm)
Length between centres	5.123 to 5.127 in (130,12 to 130,23 mm)
Maximum bend	0.0015 in (0,038 mm) for length of the gudgeon pin
Maximum twist	0.0015 in (0,038 mm) per inch length of gudgeon pin

### Big end bearings

Diametrical clearance	0.0008 to 0.0023 in (0,020 to 0,058 mm)
End float on crankpin	0.006 to 0.013 in (0,15 to 0,33 mm)
Undersizes	0.010 in 0.020 in 0.030 in 0.040 in (0,254 mm 0,508 mm 0,762 mm 1,016 mm)

### Gudgeon pins

Length	2.626 to 2.638 in (66,70 to 67,00 mm)
Diameter	0.9374 to 0.9376 in (23,811 to 23,815 mm)
Clearance in con rod	0.0001 to 0.0006 in (0,002 to 0,015 mm)
Clearance in piston	Zero to 0.0004 in (0,010 mm)

### Pistons

Clearance in bore measured at bottom of skirt at right angles to gudgeon pin	0.0005 to 0.0015 in (0,013 to 0,039 mm)
Top compression ring groove width	0.0705 to 0.0713 in (1,790 to 1,810 mm)
Second compression ring groove width	0.0700 to 0.0709 in (1,780 to 1,800 mm)
Oil control ring groove width	0.1579 to 0.1587 in (4,010 to 4,030 mm)

### Piston rings

Number one (top) compression ring	Chrome periphery
Gap in bore	0.015 to 0.025 in (0,40 to 0,65 mm)
Clearance in groove	0.0019 to 0.0039 (0,050 to 0,082 mm)
Number two compression ring	Upper face marked 'TOP'
Gap in bore	0.015 to 0.025 in (0,40 to 0,65 mm)
Clearance in groove	0.0015 to 0.0025 in (0,040 to 0,065 mm)
Oil control — rails	
Gap in bore	0.015 to 0.055 in (0,40 to 1,40 mm)
Oil control — expander	
Gap in bore	Ends to abut

### Camshaft

Location	Overhead
Bearings	Non-serviceable
Timing chain	0.375 in (9,52 mm) pitch x 106 pitches

### Rocker shaft — 4 valve engine

Diameter of rocker shaft	0.7482 to 0.7487 in (28.148 to 28.160 mm)
Length of shaft	16.47 in (418.33 mm)
Internal diameter of rocker bore	0.7492 to 0.7497 in (19.030 to 19.042 mm)

### Oil pump

Outer ring end-float	0.004 in (0.1 mm)
Inner ring end-float	0.004 in (0.1 mm)
Outer ring to pump body diametrical clearance	0.008 in (0.2 mm)
Rotor lobe clearance	0.010 in (0.25 mm)
Relief valve spring free length	1.70 in (43.18 mm)

### Valve timing

Inlet valves open	2 valve	4 valve
Close	16° B.T.D.C.	14° B.T.D.C.
Exhaust valves open	56° A.B.D.C.	50° A.B.D.C.
Close	56° B.B.D.C.	50° B.B.D.C.
	16° A.T.D.C.	14° A.T.D.C.

**Valves — 2 valve engine**

<b>Inlet</b>	
Overall length . . . . .	4.259 to 4.269 in (108,17 to 108,43 mm)
Head diameter . . . . .	1.560 in (39,62 mm)
Angle of face . . . . .	45°
Stem diameter . . . . .	0.3107 to 0.3113 in (7,881 to 7,907 mm)
Stem to guide clearance . . . . .	0.0017 to 0.0023 in (0,043 to 0,058 mm)
<b>Exhaust</b>	
Overall length . . . . .	4.254 to 4.258 in (108,05 to 108,15 mm)
Head diameter . . . . .	1.280 in (32,51 mm)
Angle of face . . . . .	45°
Stem diameter . . . . .	0.3100 to 0.3106 in (7,87 to 7,89 mm)
Stem to guide clearance . . . . .	0.0014 to 0.0030 in (0,035 to 0,076 mm)

**Valve seats — 2 valve engine**

Outside diameter: Inlet . . . . .	1.6695 to 1.6705 in (42,405 to 42,430 mm)
Exhaust . . . . .	1.3335 to 1.3345 in (33,870 to 33,896 mm)
Angle of seat . . . . .	44½°

**Valve springs — 2 valve engine**

Free length . . . . .	1.600 in (40,40 mm)
Fitted length . . . . .	1.440 in (36,57 mm)
Number of working coils . . . . .	3¾

**Valves — 4 valve engine**

Head diameter . . . . .	1.38 in (35.05 mm)	Exhaust 1.21 in (30.73 mm)
Stem diameter . . . . .	0.2794 to 0.2800 in (7.097 to 7.112 mm)	0.2787 to 0.2793 in (7.078 to 7.094 mm)
Length . . . . .	4.422 to 4.432 in (112.31 to 112.57 mm)	4.518 to 4.528 in (114.75 to 115.01 mm)
Seat angle . . . . .	45°	45°

**Valve springs — 4 valve engine**

Free length (approx.) . . . . .	1.60 in (40.64 mm)
Solid length . . . . .	1.013 in (25.73 mm)
Fitted length . . . . .	1.44 in (36.58 mm)
Number of working coils fitted . . . . .	3¾
Wire diameter . . . . .	0.162 in (4.11 mm)
Inside diameter of coils . . . . .	0.800 in (20.32 mm)

**Cylinder head machining dimensions — 4 valve engine**

Inlet valve seat bore — dimension 'A' . . . . .	1.430 to 1.429 in (36.32 to 36.29 mm)
Inlet valve seat bore depth — dimension 'B' . . . . .	0.250 to 0.255 in (6.35 to 6.45 mm)
Exhaust valve seat bore — dimension 'C' . . . . .	1.281 to 1.282 in (32.53 to 32.56 mm)
Exhaust valve seat bore — dimension 'D' . . . . .	0.250 to 0.255 in (6.35 to 6.45 mm)

**Valve seat inserts — 4 valve engine**

Outside diameter . . . . .	<b>Inlet</b> 1.4235 to 1.4245 in (36.157 to 36.182 mm)	<b>Exhaust</b> 1.2755 to 1.2765 in (32.397 to 32.413 mm)
Height . . . . .	0.248 to 0.250 in (6.29 to 6.35 mm)	0.248 to 0.250 in (6.29 to 6.35 mm)
Seat angle . . . . .	89° inclusive angle	89° inclusive angle
Seat width . . . . .	0.060 in (1.524 mm)	0.080 in (2.032 mm)

<b>Lubrication</b>	
System	Wet sump, pressure fed
Oil warning light extinguishes at	3 to 5 lbf/in <sup>2</sup> (0,21 to 0,35 kgf/cm <sup>2</sup> )
Oil filter	Full-flow, replaceable element
Oil pump type	Hobourn-Eaton
Oil pressure relief valve	
Type	Non-adjustable

<b>FUEL SYSTEM</b>	
Carburetter	Refer to 'ENGINE TUNING DATA'
Fuel pump	Mechanically-operated, diaphragm-type
Operating pressure	2.5 to 3.5 lbf/in <sup>2</sup> (0,17 to 0,24 kgf/cm <sup>2</sup> )

<b>COOLING SYSTEM</b>	
Type	Pressurized spill return with thermostat control, pump and fan-assisted
Type of pump	Centrifugal
Thermostat	88°C (190°F)
Pressure cap	15 lbf/in <sup>2</sup> (1,05 kgf/cm <sup>2</sup> )

<b>CLUTCH</b>	
Make/type	Borg & Beck, diaphragm-type
Clutch plate diameter	8.5 in (215,9 mm)
Facing material	2124F
Number of damper springs	6
Damper spring colours	Red and Violet
Clutch release bearing	Ball journal
Clutch fluid	Refer to 'LUBRICANTS'

<b>GEARBOX - 4 speed</b>	
Type	Single helical, constant mesh
Speeds	4 forward, 1 reverse
Synchromesh	All forward speeds
Ratios: Fourth (Top)	1.00 : 1
Third	1.25 : 1
Second	1.78 : 1
First	2.65 : 1
Reverse	3.98 : 1
Overall ratios: Fourth (Top)	3.63 : 1
Third	4.56 : 1
First	9.62 : 1
Reverse	10.95 : 1

<b>GEARBOX - 5 speed</b>	
Type	Single helical, constant mesh
Speeds	5 forward, 1 reverse
Synchromesh	All forward speeds
Ratios: Fifth (Top)	0.83 : 1
Fourth	1.00 : 1
Third	1.40 : 1
Second	2.09 : 1
First	3.32 : 1
Reverse	3.43 : 1
Overall ratios: Fifth (Top)	3.24 : 1
Fourth	3.90 : 1
Third	5.46 : 1
Second	8.15 : 1
First	12.95 : 1
Reverse	13.38 : 1

<b>GEARBOX - AUTOMATIC</b>				
Type	Borg Warner 65			
Transmission conversion range	3rd 1.00-1.91	2nd 1.45-2.77	1st 2.39-4.57	Rev. 209-3.99
Overall ratios to 1	3.27-6.25	4.74-9.05	7.82-14.95	6.85-13.08
Road speed corresponding to 1000 engine r.p.m.				
m.p.h.	20.0-10.5			
km.p.h.	32.0-16.8			

**AUTOMATIC TRANSMISSION SHIFT SPEEDS**

Throttle Position	Zero throttle	Light throttle		Part throttle
Selector	1	2	D	D
Shift	2-1	1-2	2-3	3-2
Road speed m.p.h.	30-38	8-12	12-16	30-40
km.p.h.	48-61	13-19	23-26	48-64

Throttle Position	Kickdown						
Selector	D	D	D	1	D	2	2
Shift	1-2	2-3	3-2	2-1	3-1	1-2	2-1
Road speed m.p.h.	38-44	65-71	58-66	42-50	30-38	38-44	30-38
km.p.h.	61-71	105-114	93-106	68-81	48-61	61-71	48-61



**PROPELLER SHAFT**

Type .....  
 Universal joints .....  
 Overall length, face to face, fully compressed .....  
 936 mm (36.85 in)

**FINAL DRIVE — Used with 4 speed gearbox**

Type .....  
 Ratio .....  
 Hypoid  
 3.63 : 1

**FINAL DRIVE — Used with 5 speed gearbox**

Type .....  
 Ratio .....  
 Hypoid  
 3.90 : 1

**SUSPENSION — UK & Europe**

Front .....  
 Independent. McPherson strut telescopic damper units with co-axial coil springs and anti-roll bar

**Coil springs**

Number of working coils ..... 5.5  
 Free length ..... 13.855 in (352.0 mm)  
 Rate ..... 93.7 lb/in (16.4 N/mm)  
 Identification ..... Red paint stripe  
 Rear ..... Four link system. Lower trailing arms, upper trailing radius rods with telescopic damper units, coil springs and anti-roll bar

**Coil spring**

Number of working coils ..... 5  
 Free length ..... 10.71 in (272.0 mm)  
 Rate ..... 165 lb/in (28.9 ± 5% N/mm)  
 Identification ..... White paint stripe

**SUSPENSION — USA Market Specifications**

Front .....  
 Independent. McPherson strut telescopic damper units with co-axial coil springs

**Coil springs**

		<b>Vehicle fitted with</b>
Number of working coils	4 & 5 speed gearbox	air conditioning
Free length	5.25	5.5
Rate	13.29 in (337.6 mm)	13.39 in (340 mm)
Identification	88 lbf/in (164 N/mm)	White & yellow
	White & blue	

Rear .....  
 Four link system. Lower trailing arms, upper trailing radius rods with telescopic damper units & coil springs

**Coil spring**

Number of working coils ..... 5  
 Free length ..... 10.27 in (261 mm)  
 Rate ..... 165 lbf/in (28.9 N/mm)  
 Identification ..... White & red

**STEERING**

Make/type ..... Alford & Alder, rack and pinion  
 Steering wheel diameter ..... 14.5 in (368 mm)  
 Steering wheel turns, lock-to-lock ..... 3.875  
 Steering angles and dimensions:  
 Front wheel alignment ..... Zero to 0.062 in (1.5 mm) toe-in  
 Camber angle ..... ¼° negative ± 1°  
 Castor angle ..... 3½° positive ± 1° } Check with the vehicle in the kerb condition  
 King pin inclination ..... 11¼° ± 1°

**BRAKES**

**Foot brake**

Type ..... Divided hydraulic system with discs at front and drums at rear  
 Operation ..... Hydraulic, servo-assisted, boost ratio 2.3 : 1 nominal

**Front brake**

Type ..... Hub-mounted discs with two pistons  
 Disc diameter ..... 9.75 in (247.6 mm)  
 Disc thickness ..... 0.375 in (9.5 mm)  
 Front pad area ..... 16.6 in<sup>2</sup> (107 cm<sup>2</sup>)  
 Front swept area ..... 183.5 in<sup>2</sup> (1182 cm<sup>2</sup>)  
 Pad material ..... FERODO 2441-FG

**Rear brake**

Type ..... Drums, service brake actuated, self-adjusting

	<b>4 speed specification</b>	<b>5 speed specification</b>
Drum internal diameter	7.995 to 8.000 in (203.20 to 203.33 mm)	8.995 to 9.000 in
Drum maximum worn dia.	8.050 in (204.47 mm)	9.050 in
Shoe arrangement	One leading & one trailing	One leading & one trailing
Shoe lining width	1.50 in (38.1 mm)	1.75 in (44.5 mm)
Lining material	DON 202 GG	
Rear lining area	46 in <sup>2</sup> (297 cm <sup>2</sup> )	60.4 in <sup>2</sup> (390 cm <sup>2</sup> )
Rear swept area	75.4 in <sup>2</sup> (486 cm <sup>2</sup> )	98.9 in <sup>2</sup> (638 cm <sup>2</sup> )

**Hand brake**

Type ..... Mechanical, operating rear shoes

**WHEELS**

Size/type ..... 5½J x 13 in dia pressed steel rims

**TYRES AND TYRE PRESSURES**

Refer to Driver's Handbook

**ELECTRICAL EQUIPMENT**

System	12 volt, negative earth
Fuses	See page 86.70.00
Battery capacity	40 amp-hour at 20 hr rate
Alternator	Lucas 17 ACR, 20 ACR air conditioning
Starter motor	Lucas 2M 100 PE
Wiper motor	Lucas 16 W
Windscreen washer pump	Lucas 103 J
Headlamp actuator	Lucas 15 W
Distributor	See 'ENGINE TUNING DATA'
Bulb chart	See 'ELECTRICAL SYSTEM'

**GENERAL DIMENSIONS (APPROXIMATE)**

Overall length	160.0 in (4065 mm) U.K & Europe 164.3 in (4173 mm) U.S.A.
Overall width	66.2 in (1681 mm)
Overall height	49.9 in (1268 mm)
Wheelbase	85.0 in (2160 mm)
Track, front	55.5 in (1409 mm)
Track, rear	55.3 in (1404 mm)
Ground clearance	4.5 in (114 mm)
Turning circle: Between kerbs	29.0 feet (8,8 m)
Between walls	31.5 feet (9,5 m)

**WEIGHTS — 4 valve engine**

	4 speed		5 speed	
Vehicle dry weight	2158 lb	979 kg	2264 lb	1027 kg
Kerbside — basic	2249 lb	1020 kg	2355 lb	1068 kg
Kerbside — with options	2403 lb	1090 kg	2463 lb	1117 kg
Vehicle capacity	571 lb	259 kg	551 lb	250 kg
Gross vehicle weight	2820 lb	1279 kg	2906 lb	1318 kg
Maximum axle load: Front	1499 lb	680 kg	1499 lb	680 kg
Rear	1349 lb	612 kg	1442 lb	654 kg
Towing capacity (braked trailer)	1684 lb	764 kg	1684 lb	764 kg
Roof rack maximum load	112 lb	51 kg	112 lb	51 kg

**CAPACITIES (NOMINAL)**

	USA	Imperial	Metric
Fuel tank (except Federal and California 2 valve)	14.4 gals	12.0 gals	54.5 litres
Fuel tank (California and Federal 2 valve)	14.6 gals	12.1 gals	55.3 litres
Engine sump and filter	9.5 pts	8.0 pts	4.5 litres
Engine sump — drain/refill	8.4 pts	7.0 pts	4.0 litres
Gearbox from dry (4 speed)	2.4 pts	2.0 pts	1.1 litres
Gearbox from dry (5 speed)	3.3 pts	2.7 pts	1.5 litres
Rear axle from dry (4 speed)	2.7 pts	2.25 pts	1.3 litres
Rear axle from dry (5 speed)	2.4 pts	2.0 pts	1.1 litres
Cooling system, including reservoir and heater or air cond. (2 valve)	15.6 pts	13 pts	7.4 litres
Cooling system, including reservoir and heater or air cond. (4 valve)	16.9 pts	14.1 pts	8.0 litres
Automatic transmission with oil cooler	11.4 pts	9.5 pts	5.4 litres

**WEIGHTS — 2 valve engine**

Showroom: Minimum	2251 lb (1021 kg)
Maximum	2282 lb (1035 kg)
Unladen: Minimum	2341 lb (1062 kg)
Maximum	2372 lb (1076 kg)
Gross vehicle weight	2866 lb (1300 kg)
Roof rack capacity	110 lb (50 kg)
Max. axle load: Front	1477 lb (670 kg)
Rear	1455 lb (660 kg)
Towing capacity — braked trailer	1680 lb (762 kg)

## PAINT AND TRIM CODING SYSTEM

The Commission number plate bears symbols for identification of the vehicle's exterior and trim colours.

### Colour Code

The basic colours are allocated a letter as shown in the table. Shades of these colours are allocated two suffix letters. For example, a commission number plate stamped 'Paint JAA, Trim PAA, denotes that the vehicle is painted 'French Blue' and trimmed 'Black'.

Basic Colour	Basic Colour Letter	Paint Trim Code					
Brown/Buff	A	AAA Beige (trim)	AAB Sand Fleck (trim)	AAC Maple	AAD Chestnut (trim)	AAE Russet Brown	
Bronze	B						
Red/Maroon	C	CAA Carmine	CAB Pimento	CAE Vermilion			
Pink	D						
Orange	E	EAA Topaz					
Yellow	F	FAA Mimosa	FAB Inca Yellow				
Gold	G						
Green	H	HAA British Racing Green	HAD Tara Green	HAE Brooklands Green			
Blue	J	JAA French Blue	JAB Delft	JAC Ice Blue	JAD Shadow Blue (trim)	JAF Astral Blue	JAG Pageant Blue
Mauve/Purple/Violet	K						
Grey	L	LAA Birch Grey (trim)	LAB Grey (trim)				
Silver/Aluminium	M						
White/Ivory/Cream	N	NAA White (trim)	NAC Sebring White (trim)	NAD Honeysuckle	NAF Leyland White		
Black	P	PAA Black (trim)	PAB Black (matt)	PAC Black (gloss)	PAD Black (rally)		
Multi-coloured	R	RAA Red/Black	RAB Green/Black				

## ENGINE TUNING DATA – UK & Europe

<b>ENGINE</b>	
Type .....	O.H.V. in line 4 cylinder
Capacity .....	122 in <sup>3</sup> (1998 cm <sup>3</sup> )
Compression ratio .....	9.25 : 1 (2 valve) 9.5 : 1 (4 valve)
Firing order .....	1 - 3 - 4 - 2
Number one cylinder .....	Front
Idle speed .....	800 rev/min
Fast idle speed (engine hot) .....	1500 to 1700 rev/min
Ignition timing: Static .....	10° B.T.D.C.
Dynamic (with vacuum pipe connected) .....	10° B.T.D.C. at 650 to 850 rev/min
Location of ignition timing marks .....	Scale on front cover – notch on pulley
Valve clearance (engine cold): Inlet .....	0.008 in (0.2 mm) (2 valve)
Exhaust .....	0.018 in (0.5 mm) (4 valve)
0.018 in (0.5 mm) (2 valve)	
0.018 in (0.5 mm) (4 valve)	
Valve clearance adjustment .....	Pallets between valve and cam follower
Valve timing .....	See page 1

### IGNITION DISTRIBUTOR

Make/type .....	A.C. Delco D302 (2 valve)
Rotation, viewed on rotor .....	Lucas 44D4 (4 valve)
Contact breaker gap .....	Anti-clockwise
Dwell angle .....	0.014 to 0.016 in (0.34 to 0.41 mm)
39° ± 1° (2 valve)	
51° ± 5° (4 valve)	
Centrifugal advance .....	} See page 356
Vacuum advance .....	

### SPARK PLUGS

Make .....	Champion
Type .....	N12Y (2 valve)
BN9Y (4 valve)	
Gap .....	0.024 to 0.026 in (0.61 to 0.66 mm)

### IGNITION COIL

Make/type .....	Lucas 15C6
Primary resistance at 20°C (68°F) .....	1.3 to 1.5 ohms

### CARBURETTERS

Make/type .....	Twin – S.U. HS6
Needle size .....	BDM (2 valve)
BDQ (4 valve)	
Jet size .....	100

## ENGINE TUNING DATA – USA Markets

### ENGINE

Type .....	O.H.V. in line 4 cylinder	
Capacity .....	122 in <sup>3</sup> (1998 cm <sup>3</sup> )	
Compression ratio .....	80.0 : 1	
Firing order .....	1 - 3 - 4 - 2	
Number one cylinder .....	Front	
Idle speed .....	800 ± 100 rev/min	
Ignition timing:	<b>Federal</b>	<b>California</b>
Static .....	10° B.T.D.C.	10° B.T.D.C.
Dynamic at idle .....	10° B.T.D.C.	2° A.T.D.C.
Location of ignition timing marks .....	Scale on front cover – notch on pulley	
Valve clearance (engine cold):		
Inlet .....	0.008 in (0.2 mm)	
Exhaust .....	0.018 in (0.5 mm)	
Valve clearance adjustment .....	Pallets between valve and cam follower	
Valve timing .....	See page 1	

### IGNITION DISTRIBUTOR – FEDERAL

#### Market Specification

Make/type .....	Lucas 47DE4
Rotation viewed on rotor .....	Anti-clockwise
Pick up air gap .....	0.014 to 0.016 in (0.35 to 0.40 mm)
Drive resistor .....	10 ± 5% ohm
Centrifugal advance .....	See page 357

### IGNITION DISTRIBUTOR –

#### CALIFORNIA Market Specification

Make/type .....	Lucas 47DE4
Rotation viewed on rotor .....	Anti-clockwise
Pick up air gap .....	0.014 to 0.016 in (0.35 to 0.40 mm)
Drive resistor .....	10 ± 5% ohm
Centrifugal advance .....	} See page 357
Vacuum retard .....	

### SPARK PLUGS

Make .....	Champion
Type .....	N12Y
Gap .....	0.024 to 0.026 in

### IGNITION COIL

Make/type .....	
Primary resistance at 20°C (68°F) .....	

### CARBURETTERS

Quantity & make .....	Two Zenith
Type .....	175 CDFVX Automatic chokes
Choke size .....	
Metering needle .....	B1DH
Orifice .....	0.100 in
Piston return spring .....	Red

Operation	Description	Specified torque			Operation	Description	Specified torque		
		Nm	lbf ft	kgf m			Nm	lbf ft	kgf m
<b>ENGINE</b>									
Air Cleaner to Carburetter	5/16" UNC Setscrew	11	8	1,1	Heater By-Pass Pipe to Inlet Manifold	11/16" Union Nut	19	14	1,9
Air Pump Adjusting Link and Mounting Bracket to Block	5/16" UNF Bolt	27	20	2,7	Hot Air Manifold to Exhaust Manifold	5/16" UNF Setscrew	27	20	2,7
Air Pump Bracket and Alternator Adjusting Link to Block	5/16" UNF Bolt	27	20	2,7	Inlet Manifold to Carburetter Flex Mounting	5/16" UNC Setscrew	27	20	2,7
Air Pump Adjusting Link Attachment	5/16" UNF Bolt	27	20	2,7	Inlet Manifold Attachment	5/16" UNC Setscrew	27	20	2,7
Air Pump to Mounting Bracket	5/16" UNF Bolt	27	20	2,7	Idler Shaft Chainwheel Attachment	3/8" UNF Setscrew	51	38	5,2
Alternator to Mounting Bracket	5/16" UNF Bolt	27	20	2,7	Oil Pump to Cylinder Block	5/16" UNF Bolt	27	20	2,7
Alternator Mounting Bracket to Bracing Link	5/16" UNF Bolt	27	20	2,7	Oil Seal Housing Attachment	1/4" UNF Setscrew	12	9	1,2
Alternator Adjusting Link and Timing Cover to Block	5/16" UNF Bolt	27	20	2,7	Oil Seal Housing Attachment	1/4" Setscrew	12	9	1,2
Bearing Caps to Block	7/16" UNF Bolt	88	65	8,9	Oil Sump Drain Plug	3/8" Dryseal Plug	34	25	3,4
Camshaft Chain Wheel Attachment	1/4" UNF Setscrew	14	10	1,38	Oil Sump to Block	5/16" UNF Bolt	27	20	2,7
Camshaft Cover Attachment	1/4" UNC Pan Hd. Setscrew	7	5	0,69	Oil Sump to Block	5/16" UNF Screw	27	20	2,7
Camshaft Bearing Cap Attachment	5/16" UNF Stud	19	14	1,9	Oil Sump to Timing Cover	5/16" UNF Screw	27	20	2,7
Camshaft Bearing Cap and Cover Attachment	5/16" UNF Stud	3	2	0,27	Oil Suction Pipe to Block	1/4" UNF Bolt	12	9	1,2
Carburetter Flexible Mounting to Inlet Manifold	5/16" UNC Setscrew	19	14	1,9	Oil Suction Pipe to Block	1/4" UNF Setscrew	12	9	1,2
Carburetter to Flexible Mounting	5/16" UNF Stud	19	14	1,9	Oil Transfer Adaptor to Block	3/8" UNF Bolt	46	34	4,7
Clutch to Flywheel	5/16" UNF Setscrew	30	22	3,0	Rear Engine Mounting to Crossmember	8 mm Setscrew	28	21	2,9
Clutch Housing to Rear Engine Plate	3/8" UNF Dowel Bolt		34	4,7	Rear Engine Mounting to Bracket	12 mm Setscrew	80	59	8,1
Clutch Housing to Rear Engine Plate	5/16" UNF Bolt	27	20	2,7	Rear Engine Mounting Bracket to Gearbox	8 mm Setscrew	228	21	2,9
Clutch Housing and Front Engine Support Bracket to Rear Engine Plate	5/16" UNF Bolt	27	20	2,7	Rear Engine Mounting Crossmember to Body	8 mm Setscrew	28	21	2,9
Clutch Housing to Block	5/16" UNF Bolt	27	20	2,7	Rear Engine Plate to Block	5/16" UNF Setscrew	27	20	2,7
Connecting Rod Bolt	3/8" Bolt	61	45	6,2	Right Hand Front Engine Mounting Bracket to Body	8 mm Setscrew	28	21	2,9
Crankshaft Pulley Attachment	5/8" UNF Bolt	160	120	16,5	Right Hand Front Engine Mounting to Engine Bracket	8 mm Setscrew	28	21	2,9
Cylinder Head to Block	7/16" UNC Bolt	75	55	7,6	Right Hand and Left Hand Engine Mounting Attachment	10 mm	50	37	5,1
Cylinder Head to Block	7/16" UNC Stud	75	55	7,6	Starter Motor to Clutch Housing	10 mm Bolt	12	9	1,2
Distributor to Block	1/4" UNF Setscrew	12	9	1,2	Throttle Linkage and Mounting Bracket Assembly to Inlet Manifold	1/4" UNC Setscrew	10	7	0,9
Diverter Valve to Mounting Bracket	1/4" UNF Setscrew	14	10	1,38	Timing Chain Tensioner to Block	1/4" UNF Bolt	12	9	1,2
Drive Plate to Crank	3/8" UNF Bolt	61	45	6,2	Timing Chain Support Bracket and Guides to Block	5/16" UNF Setscrew	27	20	2,7
Engine Stay Bracket to Block	5/16" UNF Bolt	27	20	2,7	Timing Cover to Cylinder Block	5/16" UNF Bolt	27	20	2,7
Engine Stay Attachment	3/8" UNF Jam Nut	46	34	4,7	Timing Cover to Cylinder Head	5/16" UNF Setscrew	27	20	2,7
Engine Support to Block (R.H.)	5/16" UNF Setscrew	27	20	2,7	Water Outlet Elbow to Inlet Manifold	5/16" UNF Setscrew	27	20	2,7
Evaporative Loss Canister Mounting Bracket to Body	6 mm Setscrew	10	7	0,9	Water Pump Cover to Block	5/16" UNF Setscrew	27	20	2,7
Fan to Holset Coupling	1/4" UNF Bolt	12	9	1,2	Water Pump Impeller Retaining Head	5/16" UNC Bolt	19	14	1,9
Fan Pulley Bearing Housing to Timing Cover	5/16" UNC Setscrew	19	14	1,9	Water Transfer Housing to Cylinder Head	5/16" UNC Setscrew	27	20	2,7
Flywheel to Crankshaft	3/8" UNF Bolt	61	45	6,2					
Front Lifting Eye to Block	3/8" UNF Setscrew	46	34	4,7					
Fuel Pump to Block	5/16" UNF Setscrew	19	14	1,9					
Gearbox Adaptor Attachment	5/16" UNF Stud	27	20	2,7					

Operation	Description	Specified torque			Operation	Description	Specified torque			
		Nm	lbf ft	kgf m			Nm	lbf ft	kgf m	
<b>EXHAUST SYSTEM</b>										
Exhaust Manifold Attachment	3/8" UNF Setscrew	46	34	4,7	<b>REAR AXLE — add Axle for 5sp. use</b>	Crown Wheel Attachment	3/8" UNF Bolt	62	46	6,3
Exhaust Pipe to Manifold	10 mm Stud	50	37	5,1		Drain Plug	3/8" Plug	34	25	3,4
Exhaust Pipe to Brackets on Gearbox and Clutch Housing	8 mm Setscrew	28	21	2,9		Hub to Axle Shaft	5/8" UNF on Axle	160	120	16,5
Exhaust Silencer to Front Exhaust Pipe	8 mm Bolt	10	7	0,9		Hypoid Housing to Axle Casing	5/16" UNF Bolt	27	20	2,7
Exhaust Silencer to Rear Silencer and Tail Pipe	8 mm Bolt	10	7	0,9		Hypoid Housing Bearing Cap Retention	3/8" UNF Bolt	52	38	5,2
Exhaust Support Bracket to Pipe	8 mm Setscrew	28	21	2,9		Hypoid Flange to Pinion	5/8" on Pinion	Tighten to obtain correct pre load as Specified in Division 51.		
Rear Silencer Strap to Support Bracket	8 mm Bolt	28	21	2,9		Wheel Attachment	12 mm Stud	100	75	10,3
Rear Silencer Support Bracket to Floor	8 mm on Mounting Rubber	28	21	2,9		<b>FRONT SUSPENSION</b>				
<b>CLUTCH, GEARBOX AND PROPELLER SHAFT add 5sp. gearbox</b>										
Boss to Clutch Housing	5/16" UNF Setscrew	27	20	2,7		Anti Roll Bar to Crossmember	10 mm Bolt	50	37	5,1
Clutch and Brake Pedal Mounting Bracket Attachment	8 mm Setscrew	28	21	2,9	Anti Roll Bar to Lower Link	12 mm on Bar	80	59	8,1	
Clutch Housing to Gearbox Case	3/8" UNF Wedglock Bolt	43	32	4,4	Sub-frame Attachment Front Fixing	12 mm Bolt	80	59	8,1	
Clutch Housing to Gearbox Case	3/8" UNF Setscrew	43	32	4,4	Sub-frame Attachment Rear Fixing	12 mm Bolt	80	59	8,1	
Clutch Housing to Rear Engine Plate	3/8" UNF Dowel Bolt	43	32	4,4	Damper Unit Closure Nut	1.781" x 24 UNF	81	60	8,2	
Clutch Housing to Rear Engine Plate	5/16" UNF Bolt	27	20	2,7	Hub to Stub-Axle	9/16" UNF on Axle	Tighten to 5 lbf ft (0,69 kgf m) unscrew one flat and insert pin			
Clutch Housing and Front Exhaust Support Bracket to Rear Engine Plate	5/16" UNF Bolt	27	20	2,7	Lower Link to Crossmember	12 mm Bolt	80	59	8,1	
Clutch Housing to Cylinder Block	5/16" UNF Bolt	27	20	2,7	Lower Link to Strut Assembly	1/2" Unfon Ball Joint	61	45	6,2	
Clutch Master Cylinder to Dash	8 mm Setscrew	28	21	2,9	Strut Mounting to Body	8 mm on Mounting Studs	28	21	2,9	
Cover to Gearbox Case	1/4" UNF Setscrew	12	9	1,2	Strut to Mounting	12 mm on Cartridge	60	44	6,0	
Cover Plate to Top Cover	1/4" UNF Setscrew	12	9	1,2	Tie Rod Lever to Stub Axle	12 mm Bolt	100	74	10,2	
Exhaust Pipe Support Bracket Attachment	5/16" UNF Setscrew	27	20	2,7	Wheel Attachment	12 mm Stud	100	74	10,2	
Flange to Mainshaft	5/8" UNF Nut	163	120	16,5	<b>REAR SUSPENSION</b>					
Magnetic Drain Plug	3/8" Dryseal Plug	34	25	3,4	Anti Roll Bar to Lower Link	10 mm x 30 Bolt Clamp Nut	50	37	5,1	
Oil Filler Plug	3/8" NP Taper Plug	34	25	3,4	Damper to Trailing Arm	3/8" UNF on Damper Lock Nut	27	20	2,7	
Oil Sump Coupling Plate to Clutch Housing	10 mm Setscrew	50	37	5,1	Lower Link to Body and Axle	7/16" UNF Bolt	65	48	6,6	
Overdrive Adaptor Fixings	5/16" UNF Setscrew	27	20	2,7	Upper Link to Body and Axle	7/16" UNF Bolt	65	48	6,6	
Pipe, Clutch Master Cylinder to Slave Cylinder	12 mm Tube Nut	12	9	1,2	<b>STEERING</b>					
Prop Shaft to Gearbox and Rear Axle	3/8" UNF Bolt	46	34	4,7	Rack (Pinion Side) to Crossmember	10 mm Bolt	50	29	4,0	
Prop Shaft Safety Strap Attachment	8 mm Bolt	28	21	2,9	Rack to Crossmember	10 mm Bolt	50	29	4,0	
Reverse Idler Spindle Locating Screw	5/16" UNF Pointed Setscrew	19	14	1,9	Steering Column Clamp to Upper Column	8 mm Bolt	12	9	1,2	
Selector Shaft to Forks	5/16" UNF Taper Setscrew	13	10	1,38	Steering Column Lock Shear Head Bolt	Shear Bolt	Tighten to shear			
Slave Cylinder to Boss	5/16" UNF Bolt	12	9	1,2	Steering Column to Body	Shear Bolt	Tighten to shear			
Slave Cylinder to Clutch Housing	8 mm Bolt	28	21	2,9	Steering Column Clamp Locating Plate Attachment	7/16" UNF Grub Screw	20	15	2,0	
Slave Cylinder Attachment	5/16" UNF Setscrew	27	20	2,7	Steering Column Clamp Locating Plate Attachment	7/16" UNF Jam Nut	50	37	5,1	
Sump Coupling Plate to Clutch Housing	10 mm Setscrew	50	37	5,1	Steering Column Clamp to Column	1/4" Bolt	12	9	1,2	
Top Cover to Gearbox Case	1/4" UNF Bolt	13	10	1,3						
Top Cover to Gearbox Case	1/4" UNF Setscrew	13	10	1,3						

Operation	Description	Specified torque			Operation	Description	Specified torque		
		Nm	lbf ft	kgf m			Nm	lbf ft	kgf m
Steering Column Rail to 'A' Post	6 mm Screw	10	7	0,9	Bonnet Striker Pin	3/8" UNF on striker pin	19	14	1,9
Steering Column Support Rail to Tunnel Bracket	6 mm Screw	10	7	0,9	Dash Assembly Deflector to Re-inforced Steering Column Support Rail	6 mm Weld Stud	8	6	0,8
Steering Wheel to Column	11/16" Steering Wheel Nut	50	37	5,1	Door Division Channel to Door	6 mm Setscrew	10	7	0,9
Tie Rod End Ball Joint Assembly	12 mm on Ball Joint	50	37	5,1	Door Glass Run Channel to Door	6 mm Setscrew	10	7	0,9
Tube to Support Rail	6 mm Screw	10	7	0,9	Door Hinge to Door	8 mm Stud on Hinge Assembly	28	21	2,9
Tube to Dash and Pedal Bracket	6 mm Screw	10	7	0,9	Door Lock Attachment	6 mm Setscrew Csk.	8	6	0,8
Universal Joint Assembly to Upper and Lower Columns and Rack	8 mm Bolt	28	21	2,9	Door Striker to 'B' Post	6 mm Setscrew	8	6	0,8
<b>BRAKES</b>					Fascia Attachment Brackets (Upper) to Dash Top	6 mm Setscrew	10	7	0,9
Brake and Clutch Pedal Mounting Bracket Attachment	8 mm Setscrew	28	21	2,9	Fascia Support Bracket (Lower) to Support Rail	6 mm Setscrew	8	6	0,8
Brake Master Cylinder Attachment	8 mm Stud	14	10	1,3	Fascia to Dash	6 mm Setscrew	10	7	0,9
Caliper Assembly Attachment	12 mm Bolt	100	74	10,2	Front Bumper Cover Assembly to Front Bumper Bar	6 mm Setscrew	3	2.2	0,3
Disc to Hub	3/8" UNC Bolt	43	32	4,4	Front Bumper Assembly to Body	8 mm Weld Bolt	20	15	2,0
Disc Shield Assembly to Stub Axle	6 mm Setscrew	10	7	0,9	Front Tie Down Bracket to Front Crossmember Panel	8 mm Setscrew	28	21	2,9
Front Hose to Caliper	10 mm Nut	15	11	1,4	Front Upper Assembly to Front Fenders	6 mm Setscrew	10	7	0,9
Hand Brake Cable to Lever on Backplate	5/16" UNF Fork End	10	7	0,9	Fuel Tank Attachment	10 mm Stud	50	37	5,1
Hand Brake Compensator Lever to Abutment Boss	6 mm Setscrew	10	7	0,9	Mirror Mounting Bracket to Door Bracket	6 mm Setscrew	10	7	0,9
Hand Brake Fulcrum Compensator	8 mm Nut	28	21	2,9	Mirror Mounting Bracket to Door Inner Panel	6 mm Setscrew	10	7	0,9
Hand Brake Mounting Bracket and Clamp Plate to Floor	6 mm Setscrew	10	7	0,9	Plenum Panel Fixing	6 mm Pan Head Screw	8	6	0,8
Master Cylinder to Pressure Reducing Valve	10 mm Male tube nut	12	9	1,2	Radiator Crossmember to Longitudinal Members	8 mm Setscrew	28	21	2,9
Pipe, Pressure Reducing Valve to Front Hoses	10 mm Female pipe nut	12	9	1,2	Radiator Fan Guard to Radiator Attachment	8 mm Setscrew	28	21	2,9
Pipe, Pressure Reducing Valve to Rear Hoses	10 mm Male tube nut	12	6	1,2	Radiator Mounting Bracket to Bonnet Hinge Mounting Panel	8 mm Weld Bolt	20	15	2,0
Pipe, Pressure Reducing Valve and Bracket to Turret	8 mm Bolt	28	31	2,9	Rear Bumper to Body	8 mm Weld Bolt	20	15	2,0
Rear Brake Backplate Attachment	5/16" UNF Bolt	19	14	1,9	Rear Bumper Assembly to Body	8 mm Weld Bolt	20	15	2,0
Rear Brake Drum to Hub	1/4" UNF Setscrew	10	7	0,9	Rear Bumper Corner Struts to Body	8 mm Setscrew	28	21	2,9
Rear Hose to R.H. Rear Wheel Cylinder	10 mm Female pipe nut	12	9	1,2	Rear Bumper Cover to Rear Bumper Bumper	6 mm setscrew	3	2.2	0,3
R.H. Rear Wheel Cylinder to L.H. Rear Wheel Cylinder	10 mm Male tube not	12	9	1,2	Relay Plate to Bracket on Dash Front	8 mm Weld Bolt	20	15	2,0
<b>BODY</b>					Seat Belt Buckle Assembly to Seat Slide	7/16" UNF Setscrew	43	32	4,4
Accelerator Pedal to Mounting Bracket	6 mm Setscrew	10	7	0,9	Seat Belt (Inner to Seat Slide)	7/16" UNF Setscrew	43	32	4,4
Accelerator Mounting Bracket to Dash	6 mm Setscrew	10	7	0,9	Seat Belt to Wheel Arch	7/16" UNF Setscrew	43	32	4,4
Bonnet Buffer Fixing	8 mm Jam Nut	12	9	1,2	Seat Belt to Mounting Bracket	7/16" UNF Setscrew	43	32	4,4
Bonnet Hinge to Front Panel Assembly	6 mm Setscrew	10	7	0,9	Seat Belt Warning Switch to Gearbox Extension	3/8" UNC Switch	20	15	2,0
Bonnet Lock Striker to Bonnet	8 mm Setscrew	28	21	2,9	Seat Slides to Floor	8 mm Cap Screw	28	21	2,9
Bonnet Lock to Body	8 mm Setscrew	28	21	2,9	Seat Slides to Seat Frame	6 mm Cap Screw	10	7	0,9
Bonnet Release Cable to Fascia Support Rail Bracket	1/2" UNF Jam Nut	12	9	1,2					
Body Side to Front End Assembly	6 mm Setscrew	10	7	0,9					

Operation	Description	Specified torque			Operation	Description	Specified torque		
		Nm	lbf ft	kgf m			Nm	lbf ft	kgf m
Side Lamp and Head Lamp Cables to Radiator closing Panel	6 mm Setscrew	10	7	0,9	Reverse lever mounting pin to centre plate	10 mm on pin	28	21	2,9
Trunk Lid Hinges to Trunk Lid	8 mm Setscrew	28	21	2,9	Reverse baulk plate to gearbox extension	6 mm x 40 mm Bolt	10	7	0,9
Trunk Lid Hinges to Body	6 mm Setscrew	10	7	0,9	Remove control housing to gearcase rear extension	8 mm x 40 mm Setscrew			
Trunk Lid Support to Support Bracket Tonneau	6 mm Setscrew	10	7	0,9		Setscrew	20	15	1,8
Trunk Lock to Lid	6 mm Setscrew	10	7	0,9	Speedo cable clip to gearbox	6 mm x 20 mm Setscrew	10	7	0,9
Trunk Lock Striker to Body	¼" UNF Setscrew	12	9	1,2	Torsion spring brackets to gearbox extension	6 mm x 20 mm Setscrew	10	7	0,9
Window Regulator Attachment	¼" UNF Setscrew	12	9	1,2	Torsion spring adjuster screw locking	8 mm x 25 mm Setscrew	20	15	1,8
<b>ELECTRICAL</b>									
NOTE: Refer to Section 86 for additional torque settings on proprietary items									
Battery Attachment	¼" on Fixing Rod	3	2	0,27	<b>REAR AXLE – 5 speed option</b>				
Battery Earth to Body	6 mm Setscrew	10	7	0,9	Rear cover to axle case		28	21	2,9
Headlamp Box to Hinge Arm	6 mm Weld Bolt	6	4,5	0,6	Pinion oil seal housing to axle case		50	37	4,0
Headlamp Hinge Arm to Pivot Bracket	10 mm	40	30	4,0	Differential unit bearing caps to axle case		100	75	10,2
Headlamp Hinge Arm to Bracket Assemblies	8 mm Setscrew	20	15	2,0	Crown wheel to differential unit (with loctite)		122	90	12,2
Headlamp Hinge Arm to Pivot Pin	8 mm	20	15	2,0	Pinion Flange to pinion		160	120	16,5
Headlamp Mechanism to Body	8 mm Weld Bolt	20	15	2,0	Axle shafts/backplates to axle casing		60	40	6,0
Headlamp Mechanism Crank Arm to Gearbox	6 mm Nut	15	11	1,4					
Headlamp Raising Link Adjustment	6 mm Jam Nut	6	4,5	0,6					
Headlamp Tension Spring Attachment	6 mm Shouldered Bolt	8	6	0,8					
Heater Mountings	6 mm Setscrew	10	7	0,9					
Horn Attachment	6 mm Setscrew	10	7	0,9					
Ignition Coil to Mounting Plate	6 mm Setscrew	10	7	0,9					
<b>GEARBOX – 5 speed option</b>									
Driving flange to mainshaft	18 mm nyloc nut	200	150	20,4					
Dustcap assembly to extension housing	6 mm x 12 mm Setscrew	10	7	0,9					
Extension and centre plate to main case	8 mm x 55 mm bolt	28	21	2,9					
Fifth gear selector fork pivot bracket to centre plate	8 mm x 25 mm	28	21	2,9					
Front cover to maincase	8 mm x 25 mm Setscrew	28	21	2,9					
Interlock spool retainer to gearbox case	6 mm x 16 mm Setscrew	10	7	0,9					
'J' coupling pin to main selector shaft	8 mm on pin	20	15	1,8					
Mounting bracket upper fixing	8 mm x 20 mm Setscrew	28	21	2,9					
Mounting bracket lower fixing	8 mm x 30 mm Bolt	28	21	2,9					
Magnetic drain plug	16 mm Plug	35	26	3,5					
Oil pump body to rear extension	6 mm x 20 mm screw	10	7	0,9					
Oil inlet access hole blanking	8 mm x 8 mm socket Locwel Setscrew	20	15	1,8					



## RECOMMENDED LUBRICANTS &amp; ANTI-FREEZE SOLUTIONS – BRITISH ISLES – ALL SEASONS

COMPONENT	BP	CASTROL	DUCKHAMS	ESSO	MOBIL	PETROFINA	TEXACO	SHELL
Engine Carburetter Dashpots and Oil can  Oils must meet Leyland Cars Specification BLS.OL.02	BP Super Visco-Static 20-50	Castrol GTX	Duckhams Q Motor Oil	Esso Uniflo 15W/50	Mobiloil Super 15W-50	Fina Super grade Motor Oil S.A.E. 20W-50	Havoline Motor Oil 20W-50	Shell Super Multigrade 20W-50
Manual Gearbox - 4 Speed*	BP Gear Oil S.A.E. 90 EP	Castrol Hypoy	Duckhams Hypoid 90	Esso Gear Oil GX 85W/140	Mobilube HD 90	Fina Pontonic MP S.A.E. 90	Texaco Multigear Lubricant EP 90	Shell Spirax 90 EP
Manual Gearbox - 5 Speed†	BP Gear Oil S.A.E. 80 EP	Castrol Hypoy B 75	Duckhams Hypoid 75	Esso Gear Oil GP 80W	Mobilube HD 80	Fina Pontonic MP SAE 80	Texaco Multigear Lubricant EP 80	Shell Spirax HD 75/80W
Rear Axle	BP Gear Oil S.A.E. 90 EP	Castrol Hypoy	Duckhams Hypoid 90	Esso Gear Oil GX 85W/140	Mobilube HD 90	Fina Pontonic MP S.A.E. 90	Texaco Multigear Lubricant EP 90	Shell Spirax 90 EP
Rear Hubs, Brake Cables, Grease Gun‡	BP Energrease L 2	Castrol LM Grease	Duckhams LD 10 Grease	Esso Multi- Purpose Grease H	Mobilgrease MP or MS	Fina Marson HTL 2 Grease	Marfak All Purpose Grease	Shell Retinax A
Automatic Transmission and Power Steering	BP Autran B	Castrol TQF	Duckhams 'Q'-Matic	Esso Glide	Mobil ATF 210	Fina Purfimatic 33F	Texamatic Type 'F'	Shell Donax T7
Clutch and Brake Reservoirs	Unipart Universal Brake Fluid or other brake fluids having a minimum boiling point of 260°C (500°F) and complying with FMVSS DOT 3 or SAE J1703 specification.							
Approved Anti-Freeze	Unipart Universal Anti-Freeze.							
	* Manual gearbox, if drained, MUST be refilled with Hypoid 75W gear oil.							
	† Manual gearbox, if drained, MUST be refilled with Hypoid 75W gear oil. For service top-up use Hypoid 75W gear oil, or where this oil is not available, the Hypoid 80W oils shown above may be used.							
	‡ Front hub grease – Mobilgrease MS or Super.							

## RECOMMENDED LUBRICANTS AND ANTI-FREEZE SOLUTIONS – OVERSEAS MARKETS

	SERVICE CLASSIFICATION	AMBIENT TEMPERATURE °C					
		-30	-20	-10	0	+10	+20
ENGINE	Oils must meet Leyland Cars' Specification BLS.OL.02 and/or the European Motor Manufacturers' requirements and/or A.P.I.-SE Performance Level						
FINAL DRIVE	A.P.I. – GL5 MIL-L-2105B						
MANUAL GEARBOX* – 4 SPEED	A.P.I. – GL4 MIL-L-2105						
MANUAL GEARBOX† – 5 SPEED	A.P.I. – GL4 MIL-L-2105						
AUTOMATIC GEARBOX POWER STEERING	ATF TYPE F						
HUBS‡ AND CHASSIS GREASE POINTS	N.L.G.I.–2 Multi-purpose Grease						
BRAKE & CLUTCH RESERVOIRS – USA	LOCKHEED 3295 UNIVERSAL BRAKE FLUID or other brake fluids having a minimum boiling point of 260°C (500°F) and complying with FMVSS 116 DOT3 specifications.						
– except USA	UNIPART UNIVERSAL BRAKE FLUID or other brake fluids having a minimum boiling point of 260°C (500°F) and complying with FMVSS 116 DOT3 or S.A.E. J1703d specifications.						
ANTI-FREEZE	Permanent type ethylene glycol base with suitable inhibitor for MIXED METAL ENGINES.						
WINDSHIELD WASHER	Windshield Washer Anti-Freeze Fluid (Proprietary Brands).						

\* Manual gearbox, if drained, MUST be refilled with Hypoid 75W gear oil.

† Manual gearbox, if drained, MUST be refilled with Hypoid 75W gear oil. For Service top-up use Hypoid 75W gear oil, or where this oil is not available, Hypoid 80W oils may be used.

‡ Front hub grease = N.L.G.I. No. 2 high melting-point grease.

## RECOMMENDED LUBRICANTS, FLUIDS AND FUEL -- CAPACITIES

## ANTI-FREEZE SOLUTIONS

ANTI-FREEZE CONCENTRATION		25%	30%	35%	50%
SPECIFIC GRAVITY OF COOLANT AT 15.5° C (60° F)		1.039	1.048	1.054	1.076
ANTI-FREEZE QUANTITY	US pints	3.875	4.65	5.425	7.75
	UK pints	3.25	3.9	4.55	6.5
	Litres	1,85	2,22	2,59	3,7
DEGREE OF PROTECTION	<b>Complete</b> Car may be driven away immediately from cold	-12° C 10° F	-16° C 3° F	-20° C -4° F	-36° C -33° F
	<b>Safe Limit</b> Coolant in mushy state. Engine may be started and driven away after short warm-up period	-18° C 0° F	-22° C -8° F	-28° C -18° F	-41° C -42° F
	<b>Lower Protection</b> Prevents frost damage to cylinder head, block and radiator. Thaw out before starting engine.	-26° C -15° F	-32° C -26° F	-37° C -35° F	-47° C -53° F

**LUBRICATION** -- Note. Figures in *italics* refer to U.S.A. market specification vehicles

**NOTE:** Ensure that the vehicle is standing on a level surface when checking the oil levels.

**Weekly or before a long journey**

- 1 Check/top up cooling system level.
- 13 Check engine oil level.

**Every 3,000 Miles (5,000 km) – 3, 9, 16, 22, 28, 34, 41, 47 miles x 1000**

- 1 Check/top up cooling system level.
- 13 Check/top up engine oil level.
- 12 Check/top up brake fluid reservoir.
- 11 Check/top up clutch fluid reservoir.

**Every 6,000 Miles (10,000 km) – 6, 19, 31, 44 miles x 1000**

- 1 Check/top up cooling system.
- 12 Check/top up brake fluid reservoir.
- 11 Check/top up clutch fluid reservoir.
- 13 Drain engine oil and refill.
- 3 Renew oil filter.
- 10 Lubricate accelerator linkage/pedal fulcrum.
- 4 Clean and grease battery connections.
- 6 Check/top up level of gearbox oil.
- 8 Check/top up level of final drive oil.
- 14 Lubricate steering rack and pinion.
- 7 Lubricate handbrake linkage and cable guides.
- 9 Lubricate brake and clutch pedal pivots.  
Lubricate all locks, door hinges, strikers and bonnet release.

**Every 12,000 Miles (20,000 km) – 12.5, 25, 37.5, 50 miles x 1000**

- 1 Check/top up cooling system.
- 12 Check/top up brake fluid reservoir.
- 11 Check/top up clutch fluid reservoir.
- 13 Drain engine oil and refill.
- 3 Renew oil filter.
- 10 Lubricate accelerator linkage/pedal fulcrum.
- 4 Clean and grease battery connections.
- 6 Check/top up level of gearbox oil.
- 8 Check/top up level of final drive oil.
- 14 Lubricate steering rack and pinion.
- 7 Lubricate handbrake linkage and cable guides.

- 9 Lubricate brake and clutch pedal pivots.  
Lubricate all locks, door hinges, strikers and bonnet release.
- 5 Lubricate distributor.
- 2 Check/top up carburettor piston dampers.

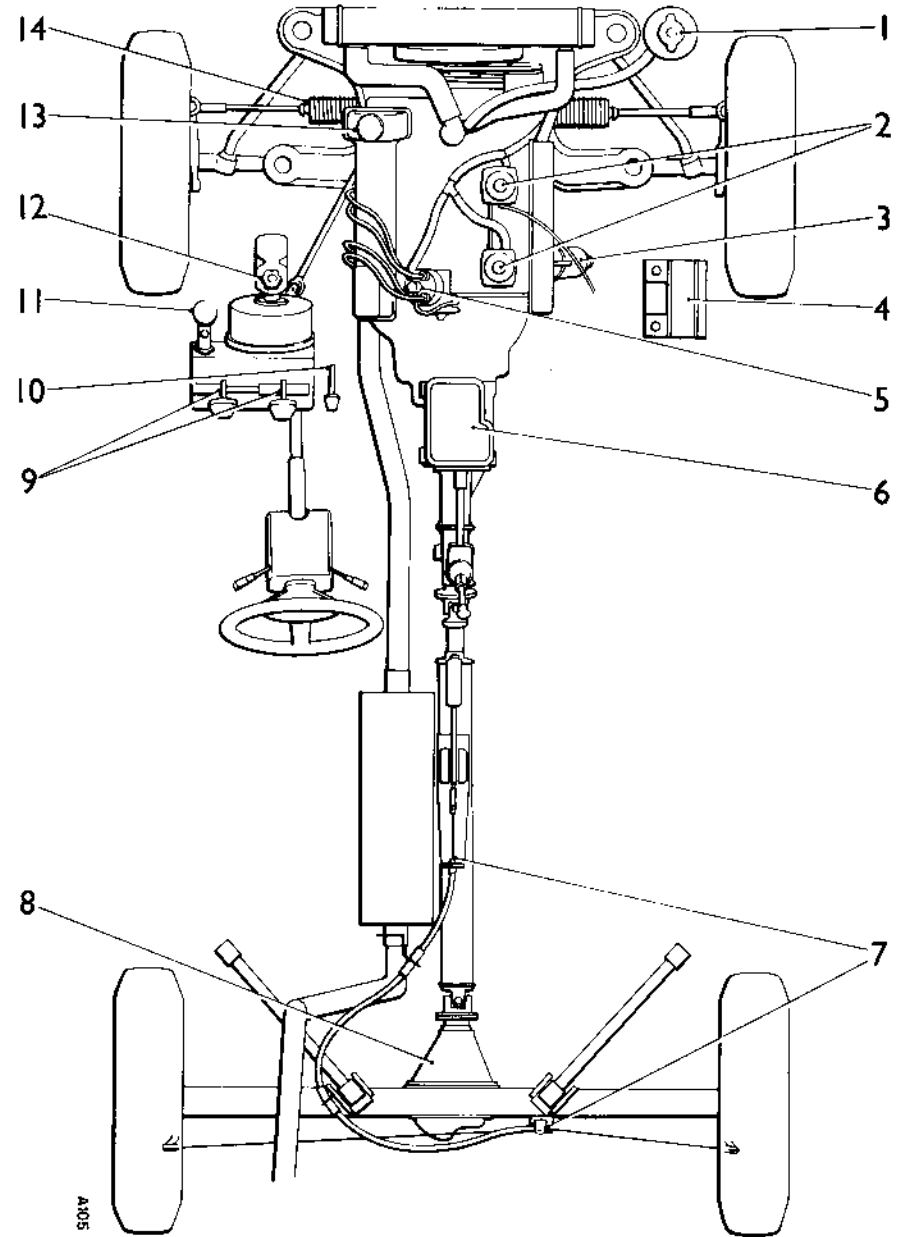

A105

KEY: MILEAGE x 1,000 MILES

OPERATION No.	MILEAGE	SERVICE
10.10.03	1	
10.10.06	3, 9, 15, 21, 27, 33, 39, 45	C
10.10.12	6, 18, 30, 42	A
10.10.24	12, 24, 36, 48	B

OPERATION Description	SERVICE	1000 Miles	C	A	B
<b>ENGINE</b>					
1 Check/top up engine oil			X		
2 Check/top up cooling system		X	X	X	X
3 Check/adjust operation of all washers and top up reservoirs		X	X	X	X
4 Renew engine oil		X		X	X
5 Renew engine oil filter				X	X
6 Lubricate accelerator control linkage (and pedal pivot) – check operation		X		X	X
7 Check cooling and heater system for leaks and hoses for security and condition		X	X	X	X
8 Check for oil leaks		X	X	X	X
9 Check/adjust torque of cylinder head nuts/bolts		X			
10 Check driving belts, adjust or renew		X	X	X	X
11 Check security of engine mountings		X			
12 Check/adjust carburetter idle settings		X		X	X
13 Top up carburetter piston dampers		X		X	X
14 Renew carburetter air cleaner element					X
15 Clean fuel pump filter		X			X
<b>IGNITION</b>					
16 Clean/adjust spark plugs				X	
17 Renew spark plugs					X
18 Check distributor points: adjust or renew				X	X
19 Lubricate distributor		X		X	X
20 Check/adjust ignition timing using electronic equipment		X		X	X

SERVICE	1000 Miles	C	A	B
<b>TRANSMISSION</b>				
21 Check for oil leaks	X	X	X	X
22 Check/top up gearbox oil	X		X	X
23 Check/top up rear axle/final drive oil	X		X	X
24 Check tightness of propeller shaft coupling bolts				X
25 Check clutch pipes for leaks and chafing	X	X	X	X
26 Check/top up clutch fluid reservoir	X	X	X	X
27 Lubricate clutch pedal pivots				X
<b>STEERING AND SUSPENSION</b>				
28 Check steering rack/gear for oil/fluid leaks	X	X	X	X
29 Check security of suspension fixings	X			X
30 Check condition and security of steering unit, joints and gaiters	X	X	X	X
31 Check/adjust front wheel alignment	X		X	X
32 Adjust front hub bearing end float				X
33 Lubricate steering rack and pinion			X	X
34 Check shock absorbers for fluid leaks	X	X	X	X
<b>BRAKES</b>				
35 Inspect brake pads for wear and discs for condition		X		
36 Inspect brake linings/pads for wear and drums/discs for condition			X	X
37 Check/top up brake fluid reservoir(s)	X	X	X	X
38 Check foot-brake operation: adjust to manufacturer's instructions (Self-adjusting)	X		X	X
39 Check handbrake operation, adjust to manufacturer's instructions	X		X	X
40 Lubricate brake pedal pivot(s)				X
41 Lubricate handbrake mechanical linkage and cable guides (lever pivot)			X	X
42 Check visually hydraulic pipes and unions for chafing, leaks and corrosion	X	X	X	X
43 Check brake servo hose(s) for security and condition	X	X	X	X
<b>ELECTRICAL</b>				
44 Check function of original equipment, i.e. interior and exterior lamps, horns, wipers and warning indicators	X	X	X	X
45 Check/top up battery electrolyte	X	X	X	X
46 Clean and grease battery connections			X	X
47 Check/adjust headlamps alignment	X	X	X	X
48 Check, if necessary renew, wiper blades		X	X	X

SERVICE	1000 Miles	C	A	B
<b>EXHAUST AND FUEL PIPES</b>				
49 Check exhaust system for leaks and security	X	X	X	X
50 Check fuel system for leaks, pipes and unions for chafing and corrosion	X	X	X	X
<b>WHEELS AND TYRES</b>				
51 Check/adjust tyre pressures including spare	X	X	X	X
52 Check that tyres comply with manufacturer's specification	X	X	X	X
53 Check tightness of road wheel fastenings	X	X	X	X
54 Check tyres for external cuts in tyre fabric, exposure of ply or cord structure, lumps or bulges	X			
55 Check tyres for tread depth and visually for external cuts in tyre fabric, exposure of ply or cord structure, lumps or bulges		X	X	X
Important: If tyres do not conform with legal requirements report to owner				
<b>BODY</b>				
56 Lubricate all locks and hinges (not steering lock)	X		X	X
57 Check condition and security of seats and seat belts	X	X	X	X
58 Check rear view mirrors for cracks and crazing		X	X	X
59 Check operation of all door, bonnet and boot locks	X			X
60 Check operation of seat belt warning system		X	X	X
61 Check operation of seat belt inertia reel mechanism	X	X	X	X
62 Check operation of window controls	X			X
63 Check tightness of sub frame/body mountings	X			
64 Ensure cleanliness of controls, door handles and steering wheel	X	X	X	X
<b>ROAD TEST</b>				
65 Road/roller test and check function of all instrumentation	X		X	X
66 Report additional work required		X	X	X

At 36,000 miles (60,000 km) or 3 years (whichever is the sooner)

Renew the air filter in the brake servo unit.

## PREVENTIVE MAINTENANCE

In addition to the recommended periodical inspection of brake components it is advisable as the car ages and as a precaution against the effects of wear and deterioration to make a more searching inspection and renew parts as necessary.

It is recommended that:

- 1 Disc brake pads, drum brake linings, hoses and pipes should be examined at intervals no greater than those laid down in the Maintenance Summary Chart.
- 2 Brake fluid should be changed completely every 18,000 miles (30,000 km) or 18 months whichever is the sooner.
- 3 All fluid seals in the hydraulic system should be renewed and all flexible hoses should be examined and renewed if necessary every 36,000 miles (60,000 km) or 3 years whichever is the sooner. At the same time the working surfaces of the pistons and bores of the master cylinder, wheel cylinders and other slave cylinders should be examined and new parts fitted where necessary.

Care must be taken always to observe the following points:

- a At all times use the recommended brake fluid.
- b Never leave fluid in unsealed containers, it absorbs moisture quickly and can be dangerous if used in the brake system in this condition.
- c Fluid drained from the system or used for bleeding should be discarded.
- d The necessity for absolute cleanliness throughout cannot be over-emphasized.

Replacing brake shoes.

When it becomes necessary to renew the brake-shoes it is essential that only genuine shoes, with the correct grade of lining, are used. Always fit new shoes as complete sets, never individually or as a single wheel set. Serious consequences could result from out-of-balance braking due to the mixing of lining.

## MAINTENANCE SUMMARY - UK & Europe

The Maintenance Summary list gives details of mileage intervals for the following operations. The figure in parentheses to the left of each heading refers to the item number on the summary list.

### ENGINE

#### (1) Check/top up engine oil level

**NOTE:** Allow time for the oil to drain back into the sump after running the engine.

Stand the vehicle on level ground.

- 1 Withdraw the dipstick, wipe it clean and push fully home again before withdrawing it for reading.
- 2 Add oil via the filler cap until the level reaches the 'High' mark on the dipstick.

**DO NOT OVERFILL** and ensure that the dipstick and filler cap are replaced.

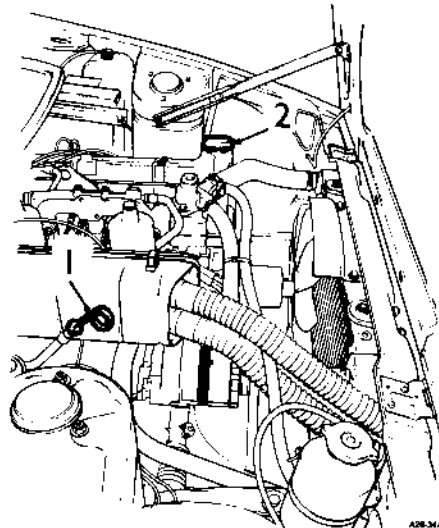

#### (2) Check/top up cooling system

**WARNING:** Do NOT remove cooling system filler caps or plugs when engine is hot.

- 1 Slowly turn the pressure cap anti-clockwise until the resistance of the safety stop is felt. Leave the cap in this position until all pressure is released. Press the cap downwards against the spring to clear the safety stops and continue turning until it can be lifted off.
- 2 Maintain the level of the coolant in the expansion tank at half full by topping up as necessary whilst the system is cool.

**NOTE:** Ensure that the specific gravity of the coolant is maintained, see 'LUBRICANTS, FLUIDS & FUEL'.

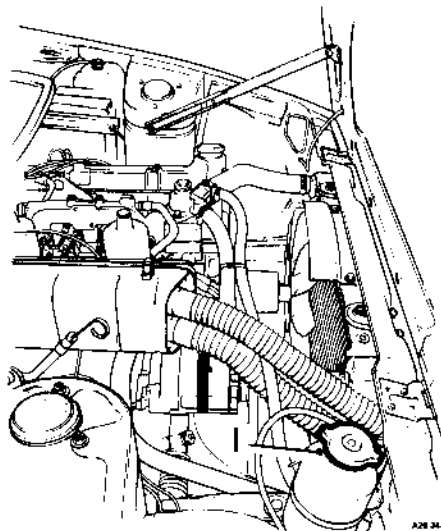

#### (3) Check/adjust operation of all washers and top up reservoirs

- 1 Replenish the container with clean soft water. The addition of a small amount of mild detergent will prevent smearing on the windscreen.
- 2 During freezing conditions it is beneficial to fill the container with a mixture of one part methylated spirits (wood alcohol) to two parts of water. This will assist in the dispersal of snow and ice from the screen.
- 3 Do not add anti-freeze solutions to the container as this will discolour the paintwork and damage wiper blades and sealing rubber.

#### (4) Renew engine oil

**NOTE:** This operation is best carried out when the engine is warm and with the vehicle standing level on a ramp or over a pit.

- 1 To drain the sump, unscrew the drain plug three complete turns to direct the oil stream into a receptacle while the engine is warm. When the rate of flow lessens remove the plug completely. Refit the plug and refill the sump with the appropriate grade of engine oil. The use of additives is unnecessary.

#### (5) Renew engine oil filter See 12.60.01 and 12.60.02.

**(6) Lubricate accelerator linkage/pedal fulcrum and check operation**

**Lubricate**

Use an oil can, lubricate the accelerator linkage on the carburetter and the accelerator pedal pivot. Wipe away any surplus oil to avoid drips or any possibility of staining the carpet inside the car.

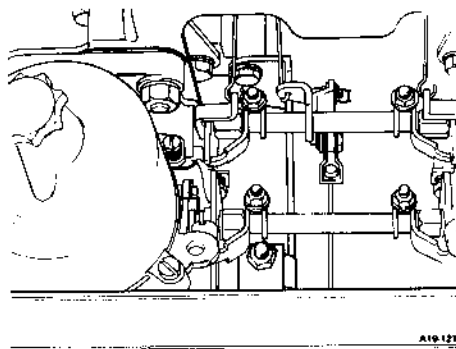

**Check operation**

Check carburetter throttle response to initial movement of the accelerator pedal. If required, adjust the throttle cable at the carburetter.

Check carburetter throttle position with accelerator pedal fully depressed, by observing that the carburetter lever(s) move to a positive stop.

If the throttle movement is not satisfactory, investigate the cause and rectify as necessary, proceeding in the following order.

Check that the throttle pedal movement is not restricted by floor mats or carpet etc.

Check the carburetter lever(s) for correct position and settings, see 19.15.01 or 19.15.02, as applicable.

Check the throttle cable location and condition, see 19.20.06.

**(7) Check cooling and heater systems for leaks and hoses for security and condition**

- 1 Check for leaks from engine and radiator drain taps/plugs (where fitted).
- 2 Check for leaks from the water hose joints.
- 3 Check for leaks from the water hoses through damage or porosity.
- 4 Check for leaks from the water pump, thermostat housing, radiator and heater unit.
- 5 Report any leaks found.

**(8) Check/report oil/fuel/fluid leaks**

- 1 Check for oil leaks from the engine and transmission.
- 2 Check for fuel leaks from the pump, carburetter pipes, joints and unions.
- 3 Check for fluid leaks from the brake master cylinder, pipes, joints and unions.
- 4 Check for fluid leaks from the clutch master cylinder, pipes, joints and unions.
- 5 Report any leaks found.

**(9) Check/adjust torque of cylinder head nuts/bolts**

See 12.29.27.

**(10) Check driving belt; adjust or renew**

Check and adjust alternator drive belt, see 86.10.05; if visibly worn or damaged, renew.

**(11) Check security of engine mountings**

Using the torque figures shown in 'TORQUE WRENCH SETTINGS'.

**(12) Check/adjust carburetter idle speed**

See 19.15.01 or 19.15.02 where applicable.

**(13) Top up carburetter piston dampers**

- 1 Unscrew and remove the damper assembly from the top of the carburetter.
- 2 Top up with clean engine oil to bring the level 13 mm (½ in) above the top of the hollow piston rod.
- 3 Push the damper assembly back into position and screw the cap firmly into the reservoir.

**NOTE:** Under no circumstances should a heavy-bodied lubricant be used.

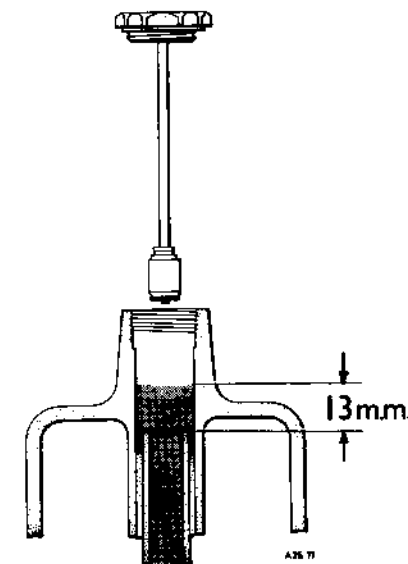
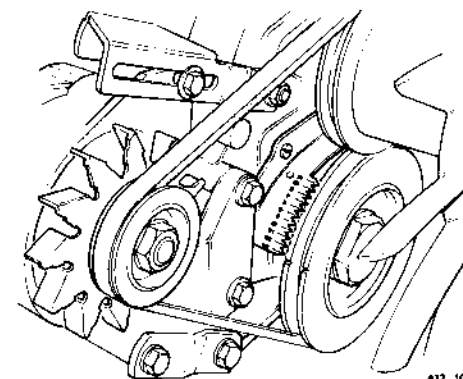



**(14) Renew carburettor air cleaner element**  
See 19.10.08.

**(15) Clean fuel pump filter**

- 1 Remove the centre bolt from the fuel pump top cover.
- 2 Withdraw the filter gauge and wash it in clean fuel.
- 3 Using a small screwdriver, loosen any sediment in the chamber.
- 4 Blow out the dirt using a low pressure air line.
- 5 Renew the gasket if necessary and refit the filter gauge and cover.

**NOTE:** Leakage of air at the gasket or centre bolt will prevent the pump from functioning correctly.

**IGNITION**

**(16) Clean/adjust spark plugs - for each spark plug in turn**

- 1 Remove the ignition high tension lead from the plug.
- 2 Unscrew the plug from the engine using a special plug spanner or a box type spanner. See (17) for method of removal.
- 3 Wipe clean the ceramic body of the plug.
- 4 Visually check the plug body for cracks and renew the plug if any cracks are present.
- 5 Unscrew the end terminal cap from the plug.
- 6 Clean the plug terminal threads with a wire brush.
- 7 Clean the cap threads using a low pressure air line.

- 8 Screw the end terminal cap firmly into position on the plug.
  - 9 Clean the electrode area and the plug threads with a wire brush or sand blasting machine.
  - 10 Visually check the electrode for damage and renew the plug if there are any signs of damage.
  - 11 Check the electrode gap, which if correct will just allow 0.025 in (0.64 mm) feeler gauge to slide slowly between the electrodes under light pressure.
- If adjustment is necessary
- 12 a Using a suitable tool, carefully move the side electrode.
  - b Check the gap, repeat this procedure until the gap is correct.
- 13 Refit the plug to the engine and tighten to the correct torque.
  - 14 Refit the high tension lead to the plug.

**(17) Renew spark plugs - for each plug in turn**

- 2 valve
- 1 Remove the ignition high tension lead from the plug.
  - 2 Unscrew the plug from the engine using a special plug spanner or a suitable box spanner.
  - 3 Discard the plug.
  - 4 Visually check the new plug for damage to the body and electrodes, discard the plug if there are any signs of damage.
  - 5 Check the electrode gap on the new plug which when correct will just allow a 0.025 in (0.64 mm) feeler gauge to slide slowly between the electrodes under light pressure.
- If adjustment is necessary, using a suitable tool carefully move the side electrode. Re-check the gap and repeat this procedure until the gap is correct.
- 6 Fit the new plug to the engine.
  - 7 Tighten the plug to the correct torque.
  - 8 Refit the high tension lead to the plug.

**4 valve**  
Tool: S 357A Plug spanner with rubber insert to hold spark plug. Supplied in vehicle tool kit.

- 1 Pull off the high tension lead, including the rubber moulding.
- 2 Locate the spanner to the spark plug.
- 3 Unscrew the spark plug.
- 4 Withdraw the spark plug and spanner together from the engine spark plug tube.
- 5 Pull the spark plug from the spanner. Check that the spark plug gap is correct, then refit as follows.
- 6 Locate the spark plug to the spanner.
- 7 Insert the spark plug and spanner together into the engine spark plug tube.
- 8 Screw in the spark plug. Torque load to 6 to 8 lbf ft (0.8 to 1.1 kgf m).  
**NOTE:** NO gasket is fitted to the spark plug.  
The cylinder head threads and tapered seat are aluminium alloy. Do not overtighten, otherwise great difficulty will be experienced when the plug is next removed and damage may be caused to the cylinder head.  
The spark plug with a gasket on a conventional Triumph engine is torque loaded to 14 to 20 lbf ft (1.9 to 2.8 kgf m). The above requirement is approximately half this figure.
- 9 Pull the spanner from the spark plug.
- 10 Push on the high tension lead, including the rubber moulding to engage the connector to the spark plug terminal.

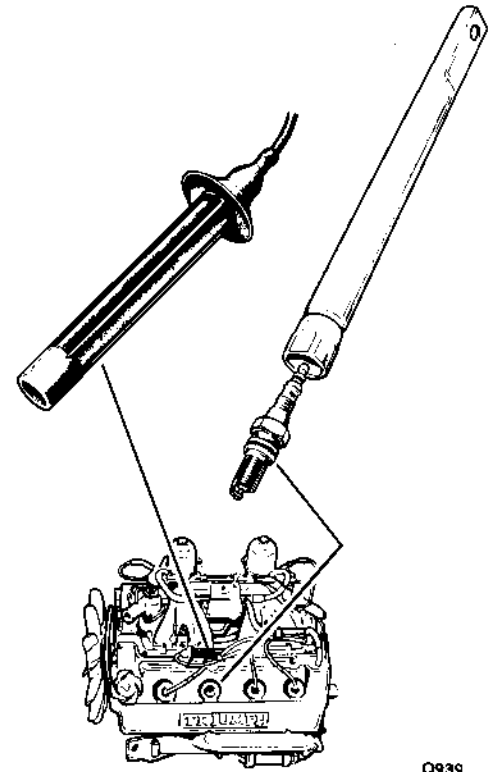

0939

**(18) Check distributor points: Adjust or renew**  
See 86.35.14.

**(19) Lubricate distributor**  
See 86.35.18

**(20) Check/adjust ignition timing using electronic equipment**  
See 86.35.00 or 86.35.15.

## TRANSMISSION

### (21) Check for oil leaks

See Maintenance Operation No. 8.

### (22) Check/top up gearbox oil

- 1 With the vehicle standing in a level position, remove the oil level/filler plug and using a suitable dispenser filled with the correct grade oil, see 'LUBRICANTS & ANTI-FREEZE SOLUTIONS', top up the gearbox until the oil is level with the bottom of the filler hole threads.
- 2 Allow surplus oil to drain away, then refit the filler plug and wipe clean.

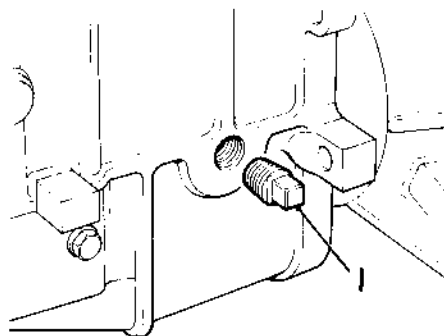

A10 18

### (23) Check/top up level of rear axle/final drive oil

- 1 With the vehicle standing in a level position, remove the oil lever/filler plug and top up the final drive unit with the correct grade oil, see 'LUBRICANTS & ANTI-FREEZE SOLUTIONS', until the oil is level with the bottom of the filler hole threads.
- 2 Allow surplus oil to drain away, then refit the filler plug and wipe clean.

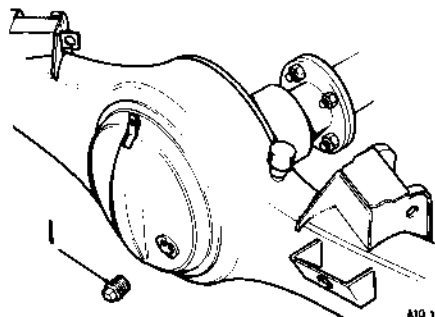

A10 19

### (24) Check tightness of propeller shaft coupling bolts

Refer to 'TORQUE WRENCH SETTINGS'.

### (25) Check clutch pipes for leaks and chafing, check visually

- 1 Clutch pipes, hoses and unions for chafing, leaks and corrosion.
- 2 Report any defects found.

### (26) Check/top up clutch fluid reservoir

Top up when required with new fluid of the type recommended, see 'LUBRICANTS & ANTI-FREEZE SOLUTIONS'.

### (27) Lubricate clutch pedal pivots

- 1 Using an oil can lubricate the clutch pedal pivot.
- 2 Wipe away the surplus oil to prevent staining the carpet.

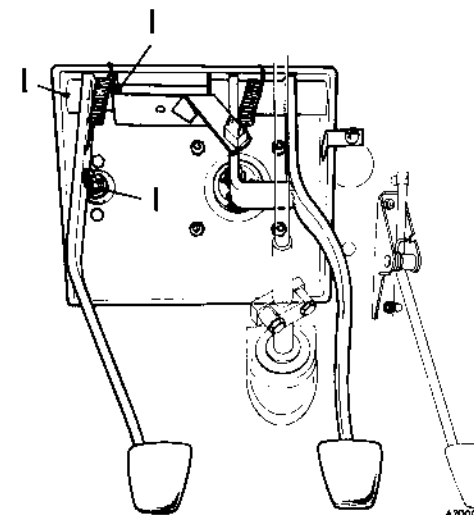

A70007

STEERING AND SUSPENSION

(28) Check steering rack/gear for oil fluid leaks

See Maintenance Operation No.8.

(29) Check security of suspension fixings

Refer to 'TORQUE WRENCH SETTINGS'.

(30) Check condition and security of steering unit, joints and gaiters

- 1 Check security of steering unit mounting and steering joints - refer to 'TORQUE WRENCH SETTINGS'.
- 2 Check steering for backlash.
- 3 Check condition of steering gaiters.
- 4 Report any defects found.

(31) Check/adjust front wheel alignment

See 57.65.01.

(32) Adjust front hub bearing end-float

- 1 Remove the road wheel.
- 2 Check the hub for end-float.
- 3 If any adjustment is required, remove the grease cap, split pin, and nut retaining cap.
- 4 Tighten the slotted nut as required to eliminate the end-float.

**NOTE:** A torque of 5 lbf ft (0.691 kgf m) must not be exceeded or damage may be caused to the bearings and the bearing tracks.

- 5 Refit the nut retaining cap.
- 6 Insert and lock the split pin.
- 7 Clean grease cap and refit.
- 8 Fit the road wheel.

(33) Lubricate steering rack and pinion

- 1 Wipe clean the plug and surrounding area.
- 2 Remove the plug.
- 3 Fit a suitable grease nipple in place of the plug.
- 4 Apply a grease gun, filled with the correct grade of grease, see 'LUBRICANTS & ANTI-FREEZE SOLUTIONS', to the grease nipple and give five strokes only.

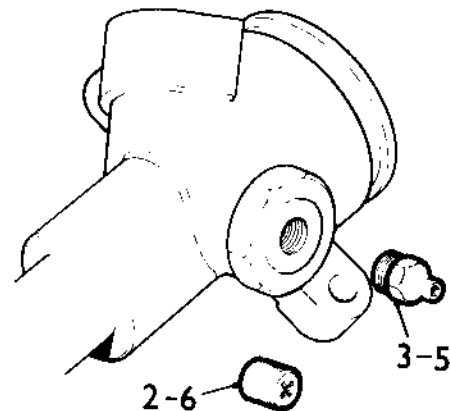

A10 20

**CAUTION:** Over greasing can cause damage to the protective bellows.

- 5 Remove the grease nipple.
- 6 Refit the plug.
- 7 Wipe away any surplus grease.

(34) Check shock absorbers for fluid leaks

Report any fluid leaks found.

BRAKES

(35) Inspect brake pads for wear and discs for condition

- 1 Jack up the front of the car and place safely onto stands before removing the disc brake pads (see 70.40.02).

**CAUTION:** Do NOT depress the brake pedal while the pads are removed.

- 2 Report pad condition if the friction lining has been reduced to 0.125 in (3 mm) or if there is not sufficient material to provide a thickness of 0.125 in (3 mm) at the completion of a further 3,000 miles (5,000 km) motoring.
- 3 Check the brake discs for excessive scoring and run out and report this if present.
- 4 Refit the pads, road wheels and lower the car.
- 5 Firmly depress the footbrake several times to correctly locate the friction pads.

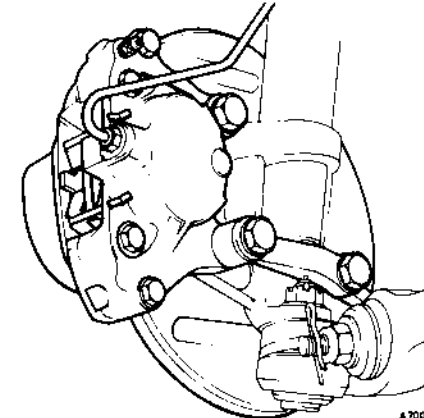

(36) Inspect brake linings/pads for wear and drums/discs for condition

- 1 Jack up the rear of the car and support the body on stands.
- 2 Remove the rear road wheels.
- 3 Remove the rear brake drum, see 70.10.03.
- 4 Check the brake linings for wear, report if they are excessively worn, damaged or contaminated by oil or grease. Remove any surplus oil or grease and dust linings and drums.
- 5 Remove the brake drum, see 70.10.03.
- 6 Fit the rear road wheels and lower the car.
- 7 See Maintenance No. 35 for the front brake pads and discs inspection.

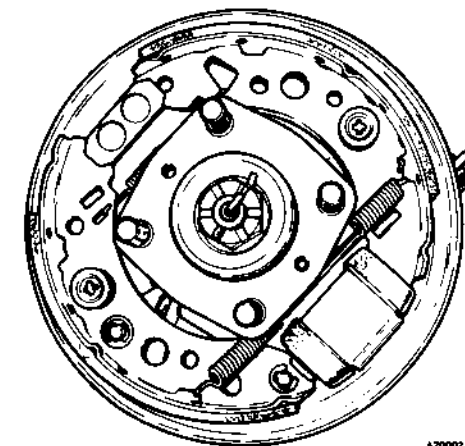

**(37) Check/top up brake fluid reservoir(s)**

- 1 Wipe clean the reservoir cap and surrounding area.
- 2 Remove the reservoir cap.
- 3 Check the fluid level against the mark on the side of the reservoir.
- 4 If necessary, add fluid to bring the level up to the mark on the side of the reservoir.

**WARNING:** Use only new fluid of the correct specification, see 'LUBRICANTS & ANTI-FREEZE SOLUTIONS'. DO NOT use fluid of unknown origin, or fluid that has been exposed to the atmosphere, or fluid that has been discharged during bleeding operations.

- 5 Replace the reservoir cap.
- 6 Remove any spilled fluid with a clean cloth.

**CAUTION:** Paintwork can be damaged by direct contact with brake fluid.

**(38) Check footbrake operation, adjust to manufacturer's instructions (Self-adjusting)**

- 1 With the handbrake off, check the brake pedal for spongy operation.
- 2 If the pedal has spongy operation, bleed and adjust the brakes, see 70.25.01.

**(39) Check handbrake operation, adjust to manufacturer's instructions**

- 1 If the handbrake travel is excessive, adjust the handbrake, see 70.35.10.

**(40) Lubricate brake pedal pivot(s)**

- 1 Using an oil can, lubricate the brake pedal pivot.
- 2 Wipe away the surplus oil to prevent staining the carpet.

**(41) Lubricate handbrake mechanical linkage and cable guides (lever pivot)**

- 1 Lubricate the handbrake pivot.
- 2 Smear grease around the handbrake lever cable connection, working it well into the clevis.
- 3 Smear grease around the brake drum cable connections, working it well into the clevis pin.
- 4 Grease the exposed section of the inner cable to combat corrosion.

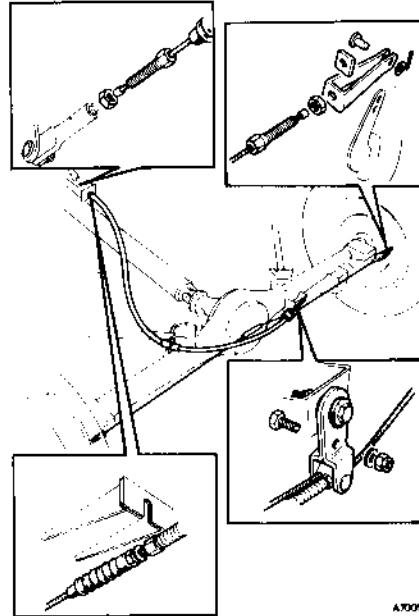

- (42) Check visually hydraulic pipes and unions for chafing, leaks and corrosion**  
Report any defects found.

- (43) Check brake servo hose(s) for security and condition**

**ELECTRICAL**

**(44) Check function of original equipment i.e. interior and exterior lamps, horns, wipers and warning indicators**

- In sequence, check operation of:
- 1 Side, tail and headlamps (including dip/main beam and 'Flash' control).
  - 2 Instrument panel illuminations.
  - 3 Interior light.
  - 4 Horns.
  - 5 Auxiliary lights.
- With ignition circuits energised, check operation of:
- 6 All warning lights:
  - 7 Fuel lever indicator.
  - 8 Heater blower motor.
  - 9 Windscreen washers.
  - 10 Windscreen wipers
  - 11 Direction indicators.
  - 12 Brake lights.
  - 13 Reversing lights.
  - 14 Start engine and note that the oil pressure warning light has extinguished.
- Check operation of:
- 15 Charging system warning light in relation to engine speed.
  - 16 Temperature indicator.
  - 17 Switch off the engine and return the ignition switch to the auxiliary position, then re-check the function of any fitted accessories e.g. a radio, that are supplied with power from this switch position.
  - 18 Report any defects found.

- (45) Check/top up battery electrolyte**  
Using **DISTILLED WATER ONLY** top up; the electrolyte level is correct when it just covers the separators.

**(46) Clean and grease battery connections**

- 1 Check the battery and surrounding area for corrosion from battery chemicals.
- 2 Clean off any corrosion found.
- 3 Check visually for cracks in the battery case and report on any case cracks found.
- 4 Check security of terminal connections.

- (47) Check/adjust headlamp alignment**  
See 86.40.17, Headlamp beam aiming.

**(48) Check, if necessary renew, wiper blades**

- 1 Examine each wiper blade in turn for damage.
- 2 With the wiper blades in position and the windscreen wet, operate the wiper motor.
- 3 Check the wiper blade operation for smearing and adequate removal of dirt.
- 4 Stop the wiper motor.
- 5 If the checks in procedures 1 and 3 are not satisfactory replace the wiper blades as necessary.  
See 84.15.06 or 84.15.07.

**EXHAUST AND FUEL PIPES**

**(49) Check exhaust system for leaks and security**

- 1 Check the security of the exhaust pipe to the manifold nuts, correct tightening torque is 37 lbf ft (5.1 kgf m).
- 2 Check the security of the exhaust pipe joint clips.
- 3 Check the security of the exhaust system mounting bolts.
- 4 Using a second operator, run the engine at fast idle speed.
- 5 Check the exhaust system joints for leaks.
- 6 Check the exhaust pipes for leaks arising from damage or deterioration.
- 7 Check the exhaust silencers for leaks arising from damage or deterioration.
- 8 Stop the engine.
- 9 Report any defects found.

**(50) Check fuel system for leaks, pipes and unions for chafing and corrosion**  
Report any defects found.

**WHEELS AND TYRES**

**(51) Check/adjust tyre pressures including spare**

Refer to Driver's Handbook for pressure settings.

**WARNING:** It can be dangerous :

- a To use a car fitted with tyres in a damaged condition.
- b To mix cross ply and radial ply tyres on the same axle or to fit radial ply tyres to the front wheels only.
- c To use a car fitted with tyres that have a tread depth of less than 0.039 in (1.0 mm) over three-quarters of the tread width for the entire circumference of the tyre.
- d To use a car with the tyres inflated to a pressure that is not suitable for the use to which the vehicle is put.

If the tyres do not conform with legal requirements report to the owner.

**(52) Check that tyres comply with manufacturer's specifications**

See 'GENERAL SPECIFICATION DATA'.

Report any deviations that may influence the car's performance or the accuracy of the speedometer.

**(53) Check tightness of road wheel fastenings**

Refer to 'TORQUE WRENCH SETTINGS'.

**(54) Check tyres for external cuts in the fabric, exposure of ply or cord structure, lumps or bulges.**

**(55) Check tyres for tread depth and visually for external cuts in tyre fabric, exposure of ply or cord structure, lumps or bulges**

**BODY**

**(56) Lubricate all locks and hinges (not steering lock)**

Using an oil can sparingly, lubricate all locks, door hinges, strikers and bonnet release. Wipe away any surplus oil to avoid staining paintwork or interior fittings.

**(57) Check condition and security of seat and seat belts**

**(58) Check rear view mirror for cracks and crazing**

**(59) Check operation of all door, bonnet and boot locks**

**(60) Check operation of seat belt warning system**

**(61) Check operation of seat belt inertia reel mechanism**

**(62) Check operation of window controls**

**(63) Check tightness of sub-frame/body mountings**

Refer to 'TORQUE WRENCH SETTINGS'.

**(64) Ensure cleanliness of controls, door handles and steering wheel**

**ROAD TEST**

**(65) Road/roller test and check function of all instrumentation**

**(66) Report additional work required**

At 36,000 miles (60,000 km) or 3 years, whichever is the sooner. Renew the air filter in the brake servo unit.

## FAULT FINDING CHART—North American Federal Specification—excluding California Specification Vehicles

This chart indicates the possible areas of fault causes. Progressively work through the 'possible causes' cross referring to the key.

Possible causes shown in brackets only relate to the condition bracketed in the fault column.

FAULT	POSSIBLE CAUSES IN ORDER OF CHECKING
Will not start	1, 2, 17, 18, 9, 10, 11, 12, 22
Poor or erratic idle	17, 30, 21, 26, 21, 11, 12, 13, 36, 38, 39, 40, 41, 6, 4, 20, 18, 31, 19, 23, 33, 34, 35, 24, 22, 29, 25, 27, 43, 42, 32, 45, 14, 47, 51, 52
Hesitation or flat spot (cold engine)	17, 18, 28, 50, 26, 33, 5, 23, 24, 25, 11, 15, 12, 35, 4, 6, 20, 27, 36, 38, 39, 40, 41, 43, 47, 49, 52, 51, 50, 48, 22, 29, 3, 14, 42
Excessive fuel consumption	19, 31, 24, 5, 26, 25, 22, 35, 4, 11, 13, 15, 12, 47, 49, 52, 51, 50, 48, 43, 6, 20, 27, 36, 38, 39, 40, 41, 29, 3, 14, 42
Lack of engine braking or high idle speed	33, 30, 32, 12, 26, 5, 22, 24, 25
Lack of engine power	17, 18, 34, 5, 35, 11, 13, 15, 12, 26, 24, 25, 22, 4, 47, 49, 52, 51, 50, 48, 43, 6, 20, 27, 36, 38, 39, 40, 41, 29, 14, 3, 42
Engine overheating	7, 12, 51, 50, 48, 26, 25, 8, 14, 42
Engine misfires	17, 18, 11, 13, 15, 12, 35, 4, 26, 24, 25, 6, 20, 27, 36, 38, 39, 40, 41, 49, 14, 3
Fuel smells	19, 31, 24, 39, 37, 38, 40, 41, 26, 25, 35
Engine 'runs on'	17, 30, 33, 32, 38, 7, 12, 51, 50, 50, 48, 26, 25, 8, 14, 42
Engine knock or 'pinking'	17, 12, 7, 51, 50, 48, 26, 25, 14, 8, 42
Arcing at plugs	13, 15
Lean running (low CO)	26, 17, 18, 24, 25, 6, 20, 27, 36, 38, 39, 40, 41, 43, 49
Rich running (excess CO)	26, 40, 24, 25, 52, 51, 50, 48, 44, 46, 45
Backfiring in exhaust	17, 18, 35, 4, 6, 12, 20, 36, 43, 27, 32

FAULT	POSSIBLE CAUSES IN ORDER OF CHECKING
Noisy air injection pump	44, 46, 45
Engine cuts out or stalls (at idle)	17, 18, (30), 35, 4, 11, 13, 15, 12, 26, 24, 25, 6, 20, 27, 36, 38, 39, 40, 41, 43, 49, 22, 23, 29, 52, 51, 50, 48, 14, 42, 3

### KEY TO POSSIBLE CAUSES

#### Basic Engine Checks

- |   |   |
|---|---|
| 1 Low battery condition or poor connections.        | 27 Leakage at throttle spindles.                  |
| 2 Starter system deficient.                         | 28 Piston damper inoperative.                     |
| 3 Poor compressions.                                | 29 Air valve spring missing, or incorrect.        |
| 4 Exhaust system leaking or blocked.                | 30 Idle speed incorrectly set.                    |
| 5 Faults on areas of the vehicle other than engine. | 31 Leakage from fuel connection joints or seals.  |
| 6 Air leaks at inlet manifold.                      | 32 Incorrectly set or faulty by-pass valve.       |
| 7 Cooling system blocked or leaking.                | 33 Sticking throttle.                             |
| 8 Cylinder head gasket leaking.                     | 34 Throttle linkage inhibited or incorrectly set. |
|   | 35 Dirty or blocked air cleaner.                  |

#### Ignition System Checks

- 9 H.T. circuit faults.
- 10 L.T. power faults.
- 11 L.T. switching faults.
- 12 Ignition timing incorrect.
- 13 System deterioration.
- 14 Advance mechanism faults.
- 15 Spark plug faults.
- 16 Distributor failure.

#### Fuel System Checks

- 17 Insufficient or incorrect fuel.
- 18 Fuel starvation.
- 19 Fuel leaks.

#### Carburettor checks

- 20 Air leak at carburettor/manifold joints.
- 21 Diaphragm uncorrectly located or damaged.
- 22 Air valve sticking.
- 23 Obstructed float chamber or diaphragm vent holes.
- 24 Incorrect fuel level in float chamber.
- 25 Metering needle faults.
- 26 Mixture incorrectly set.

#### Evaporative & Crankcase Ventilation System Checks

- 36 Engine oil filler cap loose or leaking.
- 37 Fuel filler cap defective.
- 38 Restrictors missing or blocked.
- 39 Hoses blocked or leaking.
- 40 Adsorption canister restricted or blocked.
- 41 Vapour separator blocked.
- 42 E.G.R. valve malfunction.
- 43 Leaks at E.G.R. vacuum control lines.
- 44 Incorrectly tensioned air pump driving belt.
- 45 Relief valve malfunction or insufficient + pump pressure.
- 46 Check valve sticking.
- 47 Hot air inlet hose loose, adrift or blocked.
- 48 Flap valve jammed.
- 49 Vacuum pipes disconnected or leaking.
- 50 One way (low leak) valve faults.
- 51 Temperature sensor faulty, leaking or jammed.
- 52 Flap valve diaphragm leaking.

POSSIBLE CAUSE	CHECK AND REMEDIAL ACTION	POSSIBLE CAUSE	CHECK AND REMEDIAL ACTION
1 Low battery condition or poor connections.	Check battery condition with hydrometer. Recharge, clean and secure terminals or renew as necessary. (if battery is serviceable but discharged, trace and rectify cause of flat battery e.g. short circuit or insufficient charge from alternator).		b) Check voltage at coil "- ve" terminal. If less than 2 volts, proceed to (c) below. If more than 2 volts, check the drive resistor (8-11 ohms) and renew if necessary.
2 Starter system deficient.	If starter fails to turn engine briskly, check engagement circuit and connections. Check and clean main starter circuit and connections.		c) Disconnect the white/blue lead and recheck the coil "- ve" terminal voltage. If this is more than 9 volts, check the coil by substitution. If less than 9 volts, disconnect coil "- ve" lead and again check voltage on coil "- ve" terminal. If the voltage is then 9 volts, check the coil by substitution, but, if more than 9 volts, refer to 16.
3 Poor compressions.	Check compressions with proprietary tester. If compressions are low or uneven, remove cylinder head for further examination and rectification.		Ensure ignition off and check pick-up gap in distributor. This should be 0.014 to 0.016 in (0.36 to 0.41 mm). Adjust if necessary.
4 Exhaust system leaking or	Check and rectify as necessary.	11 L.T switching faults.	Check ignition timing and adjust as necessary.
5 Faults on areas of vehicle other than engine.	Check for binding brakes, slipping clutch etc.	12 Ignition timing incorrect.	Check ignition wiring for fraying, chafing and deterioration. Check distributor cap for cracks and tracking and rotor for condition. Renew leads, cap or rotor as necessary.
6 Air leaks at inlet manifold.	Check inlet manifold/cylinder head joint. Remake with new gasket if necessary. Check manifold tappings for leaks-seal as necessary.	13 System deterioration.	Check operation of advance mechanism against figures using a stroboscopic timing light. Lubricate or renew as necessary.
7 Cooling system blocked or leaking.	Flush system and check for blockage. Check hoses and connections for security and leakage. Renew as necessary. Check thermostat and renew if faulty.	14 Advance mechanism faults.	Remove plugs, clean, reset gap and test on proprietary spark plug testing machine. Renew if in doubt.
8 Cylinder head gasket leaking.	Check cylinder block/head joint for signs of leakage. Renew gasket if necessary.	15 Spark plug faults.	a) Ensure that the distributor is earthed. b) With the distributor cap removed, crank the engine and check that the distributor shaft rotates. If not, investigate and rectify.
9 H.T. circuit faults.	Disconnect king lead at distributor and position the end approximately 3/16" (5 mm) from earthed metal. Switch on ignition, disconnect white/blue lead and check for spark at king lead end each time white/blue lead is disconnected. If spark is non-existent or weak, renew king lead and retest. If spark is satisfactory, check H.T. leads for fraying, deterioration and security, distributor cap for cracks, tracking, dirt or condensation, distributor rotor for deterioration and spark plugs. Renew leads, cap, rotor or plugs as necessary.	16 Distributor failure.	c) Recheck as detailed in 9, 10, 11, and 15.
10 L.T power faults.	a) Ensure ignition switch on and check supply voltage. If less than 11 volts, check ignition switch, wiring and connections. If more than 11 volts, check voltage at coil "+ ve" terminal. If this is in the range 4-8 volts, proceed to (b) below. If it is not 4-8 volts renew the ballast resistance wire.	17 Insufficient or incorrect fuel.	d) As the last resort, renew the distributor complete. Ensure that the fuel tank has an adequate amount of the correct type and grade of fuel.
		18 Fuel starvation.	NOTE: It is essential that unleaded fuels, are used in this vehicle otherwise serious damage can be caused to the catalytic converter. Insert a pressure gauge into the pump to carburettor fuel line and check the pressure with the engine running. If not

**POSSIBLE CAUSE****CHECK AND REMEDIAL ACTION**

satisfactory, check fuel feed and breather pipes for leaks or blockage. Renew connectors if damaged or deteriorated. If contamination of fuel is discovered, flush fuel system and clean or renew the tank filter. If necessary, renew the pump to rectify low pressure.

Check fuel system for leaks and rectify as necessary. Renew any doubtful connectors.

Check joints. Remake with new gaskets if necessary. Check CO.

Remove air valve cover and check location of diaphragm – piston depression holes should be in line with and face towards the throttle spindle. Renew diaphragm if damaged or deteriorated.

Clean air valve and guide and reassemble. Check free movement by hand-unit should move freely and return, to carburetter bridge with an audible 'click'.

23 Obstructed float chamber or Ensure that gaskets, piping or dirt are not blocking the holes.

Reset float height and clean or renew needle valve and or float as necessary.

Check that needle is correct type. Ensure that shoulder of needle is flush with face of air valve and that needle bias is correct.

Check/adjust CO at idle.

Check spindles and seals – renew as necessary.

Check/top up damper oil level. Check damper operation by raising piston by hand. Resistance should be apparent.

Check that spring is correct (colour code) and refit/renew as necessary.

Check/adjust idle speed.

Check fuel inlet connection – renew connector if necessary. Inspect float chamber joint and sealing plug 'O' ring seal – renew if necessary.

Reset or renew by-pass valve as a unit.

Check throttle operation – free off and reset as necessary.

Check that throttle linkage and accelerator pedal are not inhibited by carpets, mats, sound insulation pads etc. and that full throttle is obtainable. Lubricate and reset if necessary.

Inspect air cleaner element. Fit new element of correct type if necessary.

**POSSIBLE CAUSE****CHECK AND REMEDIAL ACTION**

36 Engine oil filler cap loose or leaking.

37 Fuel filler cap defective.

38 Restrictors missing or

39 Hoses blocked or leaking.

40 Adsorption canister restricted

41 Vapour separator blocked

42 E.G.R valve malfunction.

43 Leaks at E.G.R vacuum control lines.

44 Incorrectly tensioned air pump driving belt.

45 Relief valve malfunction or insufficient + pump pressure

46 Check valve sticking.

47 Hot air inlet hose loose, adrift or blocked.

48 Flap valve jammed.

49 Vacuum pipes disconnected or leaking.

50 One way (low leak) valve faults.

51 Temperature sensor faulty leaking or jammed.

52 Flap valve diaphragm leaking.

Check cap for security. Renew cap if seal is deteriorated.

Check seal for condition – renew if deteriorated. Check filler cap for security – rectify or renew as necessary.

Check and clear or renew as necessary.

Check and clear as necessary. Renew any deteriorated hoses.

Inspect and renew if necessary.

Check and clear or renew as necessary.

Check the function of the E.G.R valve on the vehicle. If not satisfactory, remove and clean valve and pipework. Renew valve if spring is broken, diaphragm ruptured or other fault obvious.

Check security and condition of control lines. Renew connectors or lines as necessary.

Check/adjust belt tension. Renew belt if necessary.

Check that the relief valve operates at the correct pressure by using a pressure gauge between the relief valve and outlet pipe to measure the point at which air pressure ceases to rise with engine speed. If any deviation is apparent, renew the pump/valve assembly. If the pump does not produce enough pressure to operate the relief valve check 44. and renew pump if necessary.

Disconnect air hose at check and blow through valve. If the valve obstructs flow from the pump to the manifold or allows flow from the manifold towards the pump, renew the valve after checking hoses for blockage.

Check hot air inlet hose for condition and security. Renew if necessary.

Check operation of flap valve. Renew flap valve if performance is unsatisfactory.

Check vacuum pipes for security of connections and deterioration. Renew if necessary.

Blow through valve to check "one-way" action. If the valve leaks, fit a new valve. Check and renew if necessary.

Check with a distributor vacuum test unit. If leakage is apparent, renew servo motor and cover unit.



# FAULT FINDING CHART—North American California Specification

This chart indicates the possible areas of fault causes. Progressively work through the 'possible causes' cross referring to the key.

Possible causes shown in brackets only relate to the condition bracketed in the fault column.

FAULT	POSSIBLE CAUSES IN ORDER OF CHECKING
Will not start (warm engine)	1, 2, 18, 19, 37, (38), 9, 10, 11, 12, 23
Poor or erratic idle	18, 31, 22, 27, 16, 10, 11, 12, 15, 13, 39, 42, 43, 44, 45, 6, 4, 21, 19, 32, 20, 24, 34, 35, 36, 25, 38, 23, 30, 26, 24, 28, 47, 46, 33, 49, 14, 51, 55, 56, 52, 8, 3
Hesitation or flat spot (cold engine)	18, 19, 29, (37), (54), 27, 34, 5, 24, 25, 30, 26, 11, 13, 16, 12, 15, 36, 4, 6, 21, 28, 39, 42, 43, 44, 45, 47, 51, 53, 56, 55, 54, 52, 23, 30, 3, 14, 46
Excessive fuel consumption	20, 32, 25, 5, 27, 38, 26, 23, 36, 4, 11, 13, 16, 12, 15, 51, 53, 56, 55, 54, 52, 47, 6, 21, 28, 39, 42, 43, 44, 45, 30, 3, 14, 46
Lack of engine braking or high idle speed	34, 31, 15, 33, 12, 27, 5, 23, 25, 38, 26
Lack of engine power	18, 19, 35, 5, 36, 11, 13, 16, 12, 27, 25, 38, 26, 23, 4, 51, 53, 56, 55, 54, 52, 47, 6, 21, 15, 28, 39, 42, 43, 44, 47, 30, 14, 3, 46
Engine overheating	7, 12, 15, 55, 54, 52, 27, 26, 8, 14, 46
Engine misfires	18, 19, 11, 13, 16, 12, 36, 4, 27, 25, 38, 26, 6, 21, 15, 28, 39, 42, 43, 44, 45, 53, 14, 3
Fuel smells	20, 32, 25, 43, 40, 42, 44, 45, 38, 27, 26, 36
Engine 'runs on'	18, 31, 34, 33, 42, 41, 7, 12, 27, 55, 54, 52, 27, 26, 38, 8, 14, 46
Engine knock or 'pinking'	18, 12, 15, 7, 55, 54, 52, 27, 26, 14, 8, 46
Arcing at plugs Lean running (low CO)	13, 16 27, 18, 19, 25, 26, 6, 21, 15, 28, 39, 42, 43, 44, 45, 47, 53

FAULT	POSSIBLE CAUSES IN ORDER OF CHECKING
Rich running (excess CO)	27, 44, 25, 38, 26, 56, 55, 54, 52, 48, 50, 49
Backfiring in exhaust	18, 19, 36, 4, 6, 12, 15, 21, 39, 47, 28, 33
Noisy air injection pump	48, 50, 49
Engine cuts out or stalls (at idle)	18, 19, (31), (37), 36, 4, 11, 13, 16, 12, 38, 27, 25, 26, 6, 21, 15, 28, 39, 42, 43, 44, 45, 47, 53, 23, 24, 30, 56, 55, 54, 52, 14, 46, 3

## KEY TO POSSIBLE CAUSES

### Engine checks

- 1 Low battery condition or poor connections.
- 2 Starter system deficient.
- 3 Poor compressions.
- 4 Exhaust system leaking or blocked.
- 5 Faults on areas of vehicle other than engine.
- 6 Air leaks at inlet manifold.
- 7 Cooling system blocked or leaking.
- 8 Cylinder head gasket leaking.

### Ignition System Checks

- 9 H.T. circuit faults.
- 10 L.T. power faults.
- 11 L.T. switching faults.
- 12 Ignition timing incorrect.
- 13 System deterioration.
- 14 Advance mechanism faults.
- 15 Vacuum system faults.
- 16 Spark plug faults.
- 17 Distributor failure.

### Fuel System Checks

- 18 Insufficient or incorrect fuel.
- 19 Fuel starvation.
- 20 Fuel leaks.

### Carburettor Checks

- 21 Air leak at carburettor/manifold joints.
- 22 Diaphragm incorrectly located or damaged.

- 23 Air valve sticking.
- 24 Obstructed float chamber or diaphragm vent holes.
- 25 Incorrect fuel level in float chamber.
- 26 Metering needle faults.
- 27 Mixture incorrectly set.
- 28 Leakage at throttle spindles (after considerable service).
- 29 Piston dampers inoperative.
- 30 Air valve spring missing or incorrect.
- 31 Idle speed incorrectly set.
- 32 Leakage from fuel connection joints or seals.
- 33 Incorrectly set or faulty by-pass valve.
- 34 Sticking throttle.
- 35 Throttle linkage inhibited or incorrectly set.
- 36 Dirty or blocked air cleaner.
- 37 Choke inoperative.
- 38 Choke sticking on.

### Evaporative & Crankcase Ventilation System Checks.

- 39 Engine oil filler cap loose or leaking.
- 40 Fuel Filler cap defective.
- 41 Anti-run on valve inoperative.
- 42 Restrictors missing or blocked.
- 43 Hoses blocked or leaking.
- 44 Adsorption canister restricted or blocked.
- 45 Vapour separator blocked.

### E.G.R. System Checks

- 46 E.G.R. valve malfunction.
- 47 Leaks at E.G.R. vacuum control lines.

### Air Injection System Checks

- 48 Incorrectly tensioned air pump driving belt.
- 49 Relief valve malfunction or insufficient + pump pressure.
- 50 Check valve sticking.

### Miscellaneous

- 51 Hot air inlet hose loose, adrift or blocked.
- 52 Flap valve jammed.
- 53 Vacuum piped disconnected or leaking.
- 54 One way (low leak) valve faults.
- 55 Temperature sensor faulty, leaking or jammed.
- 56 Flap valve diaphragm leaking.

### POSSIBLE CAUSE

- 1 Low battery condition or poor connections.
- 2 Starter system deficient.
- 3 Poor compressions.
- 4 Exhaust system leaking or blocked.
- 5 Faults on areas of vehicle other than engine.
- 6 Air leaks at inlet manifold.
- 7 Cooling system blocked or leaking.
- 8 Cylinder head gasket leaking.
- 9 H.T. circuit faults.

### CHECK AND REMEDIAL ACTION

Check battery condition with hydrometer. REcharge, clean and secure terminals or renew as necessary. (if battery is serviceable but discharged, trace and rectify cause of flat battery e.g. short circuit or insufficient charge from alternator).

If starter fails to turn engine briskly, check engagement circuit and connections. Check and clean main starter circuit and connections.

Check compressions with proprietary tester. If compressions are low or uneven, remove cylinder head for further examination and rectification.

Check and rectify as necessary.

Check for binding brakes, slipping clutch etc.

Check inlet manifold/cylinder head joint. Remake with new gasket if necessary. Check manifold tappings for leaks-seal as necessary.

Flush system and check for blockage. Check hoses and connections for security and leakage. Renew as necessary. Check thermostat and renew if faulty.

Check cylinder block/head joint for signs of leakage. Renew gasket if necessary.

Disconnect king lead at distributor and position the end approximately 3/16" (5 mm) from earthed metal. Switch on ignition, disconnect white/blue lead and check for spark at king lead end each time white/blue lead is disconnected. If spark is non-existent or weak, renew king lead and retest. If spark is satisfactory, check H.T. leads for fraying, deterioration and security, distributor cap for cracks, tracking, dirt or condensation,

### POSSIBLE CAUSE

- 10 L.T. power faults.

- 11 L.T. switching faults.

- 12 Ignition timing incorrect.

- 13 System deterioration.

- 14 Advance mechanism faults.

- 16 Spark plug faults.

- 17 Distributor failure.

### CHECK AND REMEDIAL ACTION

distributor rotor for deterioration and spark plugs (16). Renew leads, cap, rotor or plugs as necessary.

a) Ensure ignition switch on and check supply voltage. If less than 11 volts, check ignition switch, wiring and connections. If more than 11 volts, check voltage at coil "+ ve" terminal. If this is in the range 4-8 volts, proceed to (b) below. If it is not 4-8 volts renew the ballast resistance wire.

b) Check voltage at coil "- ve" terminal. If less than 2 volts, proceed to (c) below. If more than 2 volts, check the drive resistor (8-11 ohms) and renew if necessary.

c) Disconnect the white/blue lead and recheck the coil "- ve" terminal voltage. If this is more than 9 volts, check the coil by substitution. If less than 9 volts, disconnect coil "- ve" lead and again check voltage on coil "- ve" terminal. If the voltage is then 9 volts, check the coil by substitution, but, if more than 9 volts, refer to 17.

Ensure ignition off and check pick-up gap in distributor. This should be 0.014 to 0.016 in (0.36 to 0.41 mm). Adjust if necessary.

Check ignition timing and adjust as necessary

Check ignition wiring for fraying, chafing and deterioration. Check distributor cap for cracks and tracking and rotor for condition. Renew leads, cap or rotor as necessary.

Check operation of advance mechanism against figures using a stroboscopic timing light. Lubricate or renew as necessary.

Remove plugs, clean, reset gap and test on proprietary spark plug testing machine. Renew if in doubt.

a) Ensure that the distributor is earthed.  
b) With the distributor cap removed, crank the engine and check that the distributor shaft rotates. If not, investigate and rectify.

c) Recheck as detailed in 9, 10, 11, and 16.

d) As the last resort, renew the distributor complete.

POSSIBLE CAUSE	CHECK AND REMEDIAL ACTION	POSSIBLE CAUSE	CHECK AND REMEDIAL ACTION
18 Insufficient or incorrect fuel.	Ensure that the fuel tank has an adequate amount of the correct type and grade of fuel. <b>NOTE:</b> It is essential that unleaded fuels, are used in this vehicle otherwise serious damage can be caused to the catalytic converter.	35 Throttle linkage inhibited or incorrectly set.	Check that throttle linkage and accelerator pedal are not inhibited by carpets, mats, sound insulation pads etc. and that full throttle is obtainable. Lubricate and reset if necessary.
19 Fuel starvation.	Insert a pressure gauge into the pump to carburetter fuel line and check the pressure with the engine running. If not satisfactory, check fuel feed and breather pipes for leaks or blockage (see also 32 and 24). Renew connectors if damaged or deteriorated. If contamination of fuel is discovered, flush fuel system and clean or renew the tank filter. If necessary, renew the pump to rectify low pressure.	36 Dirty or blocked air cleaner.	Inspect air cleaner element. Fit new element of correct type if necessary.
20 Fuel leaks.	Check fuel system for leaks and rectify as necessary. Renew any doubtful connectors.	37 Choke inoperative.	Check connections and seals of mixture feed pipe at inlet manifold and autochoke. Check connections of water feed pipes and bleed autochoke system. Check electrical connections, at cut-out switch on inlet manifold, and autochoke. If still unsatisfactory renew autochoke.
21 Air leak at carburetter/manifold joints.	Check joints. Remake with new gaskets if necessary. Check CO.	38 Choke sticking on.	Bleed autochoke.
22 Diaphragm incorrectly located or damaged.	Remove air valve cover and check location of diaphragm - piston depression holes should be in line with and face towards the throttle spindle. Renew diaphragm if damaged or deteriorated.	39 Engine oil filler cap loose or leaking.	Check cap for security. Renew cap if seal is deteriorated.
23 Air valve sticking.	Clean air valve and guide and reassemble. Check free movement by hand-unit should move freely and return, to carburetter bridge with an audible 'click'.	40 Fuel filler cap defective.	Check seal for condition - renew if deteriorated. Check filler cap for security - rectify or renew as necessary.
24 Obstructed float chamber or diaphragm vent holes.	Ensure that gaskets, piping or dirt are not blocking the holes.	41 Anti-run on valve inoperative	Apply current to the run on valve solenoid with the engine running. If the engine does not stop, the valve is suspect - renew valve and retest. If the engine does not stop, check wiring between valve, control (oil pressure) switch and the ignition switch.
25 Incorrect fuel level in float chamber.	Reset float height and clean or renew needle valve and or float as necessary.	42 Restrictors missing or blocked.	Check and clear or renew as necessary.
26 Metering needle faults.	Check that needle is correct type. Ensure that shoulder of needle is flush with face of air valve and that needle bias is correct.	43 Hoses blocked or leaking.	Check and clear as necessary. Renew any deteriorated hoses.
27 Mixture incorrectly set.	Check/adjust CO at idle.	44 Adsorption canister restricted or blocked.	Inspect and renew if necessary.
28 (After considerable service) leakage at throttle spindles.	Check spindles and seals - renew as necessary.	45 Vapour separator blocked.	Check and clear or renew as necessary.
29 Piston damper inoperative.	Check/top up damper oil level - Check damper operation by raising piston by hand. Resistance should be apparent.	46 E.G.R. valve malfunction.	Check the function of the E.G.R. valve on the vehicle. If not satisfactory, remove and clean valve and pipework. Renew valve if spring is broken, diaphragm ruptured or other fault obvious.
30 Air valve spring missing, or incorrect.	Check that spring is correct (colour code) and refit/renew as necessary.	47 Leaks at E.G.R. vacuum control lines.	Check security and condition of control lines. Renew connectors or lines as necessary.
31 Idle speed incorrectly set.	Check/adjust idle speed.	48 Incorrectly tensioned air pump driving belt.	Check/adjust belt tension. Renew belt if necessary.
32 Leakage from fuel connection, joints or seals.	Check fuel inlet connection - renew connector if necessary. Inspect float chamber joint and sealing plug 'O' ring seal - renew if necessary.	49 Relief valve malfunction, or insufficient + pump pressure.	Check that the relief valve operates at the correct pressure by using a pressure gauge between the relief valve and outlet pipe to measure the point at which air pressure ceases to rise with engine speed. If any deviation is apparent, renew the pump/valve assembly. If the pump does not produce enough pressure to operate the relief valve check 48 and renew pump if necessary.
33 Incorrectly set or faulty by-pass valve.	Reset or renew by-pass valve as a unit.		
34 Sticking throttle.	Check throttle operation - free off and reset as necessary.		

**POSSIBLE CAUSE**

**CHECK AND REMEDIAL ACTION**

50 Check valve sticking.

Disconnect air hose at check and blow through valve. If the valve obstructs flow from the pump to the manifold or allows flow from the manifold towards the pump, renew the valve after checking hoses for blockage.

51 Hot air inlet hose loose, adrift or blocked.

Check hot air inlet hose for condition and security. Renew if necessary.

52 Flap valve jammed.

Check operation of flap valve. Renew flap valve if performance is unsatisfactory.

53 Vacuum pipes disconnected or leaking.

Check vacuum pipes for security of connections and deterioration. Renew if necessary.

54 One way (low leak) valve faults.

Blow through valve to check "one-way" action. If the valve leaks, fit a new valve. Check and renew if necessary.

55 Temperature sensor faulty, leaking or jammed.

Check and renew if necessary.

56 Flap valve diaphragm leaking.

Check with a distributor vacuum test unit. If leakage is apparent, renew servo motor and cover unit.

**MAINTENANCE SUMMARY, USA Market Specification**

KEY: MILEAGE x 1,000 MILES

OPERATION No.	MILEAGE
10.10.03	1
10.10.14	3, 9, 16, 22, 28, 34, 41, 47
10.10.26	6, 19, 31, 44
10.10.28	12.5, 37.5
10.10.50	25, 50

Key to operation numbers and mileage	10. 10. 03	10. 10. 14	10. 10. 26	10. 10. 28	10. 10. 50
<b>Operation Description</b>					
<b>ENGINE</b>					
1 Check/top up engine oil		X			
2 Check/top up cooling system	X	X	X	X	X
3 Check/adjust operation of all washers and top up reservoir	X	X	X	X	X
4 Renew engine oil	X		X	X	X
5 Renew engine oil filter			X	X	X
6 Lubricate accelerator control linkage and pedal pivot - check operation	X		X	X	X
7 Check cooling/heater systems for leaks and hoses for security and condition	X	X	X	X	X
8 Check for oil leaks	X	X	X	X	X
9 Check/adjust torque of cylinder head nuts/bolts	X				
10 Check driving belts, adjust or renew	X			X	X
11 Check security of engine mountings	X				
12 Check/adjust carburetter idle settings	X			X	X
13 Top up carburetter, piston damper(s)	X			X	X
14 Renew carburetter/air intake, air cleaner element				X	X
15 Check/adjust deceleration by-pass valve	X			X	X
16 Check security of E.G.R. valve operating lines	X				
17 Check E.G.R. system					X
18 Check air-intake temperature control system				X	X

Key to operation numbers and mileage intervals	10. 10. 03	10. 10. 14	10. 10. 26	10. 10. 28	10. 10. 50
19 Check crankcase breathing and evaporate loss system hoses for security	X				
20 Check crankcase breathing and evaporative loss systems. Check hoses/pipes and restrictors for blockage, security and condition				X	X
21 Check air injection system hoses/pipes for security and condition				X	X
22 Check/top up air conditioning compressor fluid				X	X
23 Renew adsorption canister					50 only
24 Renew catalytic converter					50 only
<b>IGNITION</b>					
25 Check security of distributor vacuum unit and operation of vacuum unit (California Market only)	X			X	X
26 Lubricate distributor				X	X
27 Check/adjust ignition timing using electronic equipment	X			X	X
28 Check ignition wiring for fraying, chafing and deterioration	X			X	X
29 Clean distributor cap, check for cracks and tracking				X	X
30 Renew spark plugs				X	X
31 Check coil performance on oscilloscope				X	X
<b>TRANSMISSION</b>					
32 Check/top up gearbox oil	X		X	X	X
33 Check/top up rear axle/final drive oil	X		X	X	X
34 Check for oil leaks	X	X	X	X	X
35 Check tightness of propeller shaft coupling bolts				X	X
36 Check/top up automatic gearbox fluid	X		X	X	X
37 Lubricate automatic gearbox exposed selector linkage			X	X	X

Key to operation numbers and mileage	10. 10. 03	10. 10. 14	10. 10. 26	10. 10. 28	10. 10. 50
38 Check clutch pipes for leaks and chafing	X	X	X	X	X
39 Check/top up clutch fluid reservoir	X	X	X	X	X
40 Lubricate clutch pedal pivots				X	X
<b>STEERING AND SUSPENSION</b>					
41 Check steering rack for oil leaks	X	X	X	X	X
42 Check security of suspension fixings	X			X	X
43 Check condition and security of steering unit joints and gaiters	X	X	X	X	X
44 Check/adjust front wheel alignment	X		X	X	X
45 Adjust front hub bearing end float				X	X
46 Lubricate steering rack and pinion			X	X	X
47 Check shock absorber for fluid leaks	X	X	X	X	X
<b>BRAKES</b>					
48 Inspect brake pads for wear and discs for condition		X			
49 Inspect brake linings/pads for wear, and drums/discs for condition			X	X	X
50 Check/top up brake fluid reservoir	X	X	X	X	X
51 Check footbrake operation; adjust to manufacturer's instructions (self-adjusting)	X		X	X	X
52 Check handbrake operation; adjust to manufacturer's instructions	X		X	X	X
53 Lubricate brake pedal pivot				X	X
54 Lubricate handbrake mechanical linkage and cable guides			X	X	X
55 Check visually, hydraulic pipes and unions for chafing leaks and corrosion	X	X	X	X	X
56 Check brake servo hoses for security and condition	X	X	X	X	X

Key to operation numbers and mileage	10. 10. 03	10. 10. 14	10. 10. 26	10. 10. 28	10. 10. 50
<b>ELECTRICAL</b>					
57 Check function of original equipment, i.e. interior and exterior, lamps, horns, wipers and warning indicators	X	X	X	X	X
58 Check/top up battery electrolyte	X	X	X	X	X
59 Clean and grease battery connections			X	X	X
60 Check/adjust headlamp alignment	X	X	X	X	X
61 Check, if necessary renew wiper blades		X	X	X	X
62 Check output of charging system	X		X	X	X
<b>EXHAUST AND FUEL PIPES</b>					
63 Check exhaust system for leaks and security	X	X	X	X	X
64 Check fuel system for leaks, pipes and unions for chafing and corrosion	X	X	X	X	X
65 Check condition of fuel filler cap seal				X	X
<b>WHEELS AND TYRES</b>					
66 Check/adjust tyre pressure including spare	X	X	X	X	X
67 Check that tyres comply with manufacturer's specification		X	X	X	X
68 Check tightness of road wheel fastenings	X	X	X	X	X
69 Check tyres for external cuts in tyre fabric, exposure of ply or cord structure, lumps or bulges	X				
70 Check tyres for tread depth and visually for external cuts in fabric, exposure of ply or cord structure, lumps or bulges <b>IMPORTANT:</b> If tyres do not conform with legal requirements report to the owner		X	X	X	X
<b>BODY</b>					
71 Lubricate all locks and hinges (not steering lock)	X		X	X	X

Key to operation numbers and mileage	10. 10. 03	10. 10. 14	10. 10. 26	10. 10. 28	10. 10. 50
72 Check condition and security of seats and seat belts	X	X	X	X	X
73 Check rear view mirror for cracks and crazing		X	X	X	X
74 Check operation of all door, bonnet and boot locks	X			X	X
75 Check operation of seat belt warning system		X	X	X	X
76 Check operation of seat belt inertia reel mechanism	X	X	X	X	X
77 Check operation of window controls	X			X	X
78 Check tightness of sub frame/body mountings	X				
79 Ensure cleanliness of controls, door handles, steering wheel	X	X	X	X	X
<b>GENERAL</b>					
80 Road/roller test and check function of all instrumentation	X		X	X	X
81 Report additional work required		X	X	X	X

At 37,500 miles or 3 yrs whichever is the sooner -

Renew air filter in brake servo unit

### ADDITIONAL WORK FOR CANADIAN MARKET SPECIFICATION VEHICLES

- 1 Check/adjust choke settings (manual choke) - operation Nos. 10.10.03, 10.10.28, 10.10.50.
- 2 Check operation of distributor vacuum unit - operation Nos. 10.10.28, 10.10.50.

#### (1) Check/adjust choke settings (manual choke)

- 1 Maintain the engine at normal running temperature.
- 2 Check that the mixture control cam lever on both carburetters returns to its stop.
- 3 Check and if necessary adjust the mixture control cable so that there is free movement.
- 4 Pull-out the mixture control cable knob on the control cowl approximately  $\frac{1}{4}$  in until the fast idle cams are correctly engaged with the ball locators.
- 5 Slaken the fast idle screw lock-nut on both carburetters, start the engine and rotate the screw head (on both carburetters) against the cam until the engine revolutions reach a steady 1600 rev/min.
- 6 Use the air flow meter to check that the carburetters are in balance at 1600 rev/min. if necessary adjust the fast idle screws as required.
- 7 Tighten the fast idle screw lock-nut on both carburetters and push the mixture control knob fully home.

**NOTE:** An engine set to 1600 rev/min. while hot is equivalent to a fast idle speed of approximately 1300 rev/min. when cold.

#### (2) Check operation of distributor vacuum unit.

- 1 Check security of distributor vacuum unit operating line.
- 2 Start the engine and warm to normal running temperature.
- 3 When the engine is idling steadily, disconnect the vacuum pipe at the distributor.

- 4 A noticeable rise in engine speed (approximately 500 rev/min) should be apparent if the vacuum unit is functioning, otherwise overhaul or renew the distributor.
- 5 When satisfied that the vacuum unit is operating correctly, reconnect the vacuum unit pipe, ensuring a secure connection.

### MAINTENANCE SUMMARY - North American Specification

The Maintenance Summary gives details of mileage intervals for the following operations. The figure in parenthesis to the left of each heading refers to the item number on the summary list.

#### ENGINE

##### (1) Check/top up engine oil

**NOTE:** Allow time for oil to drain back into sump after running engine.

Stand vehicle on level ground.

- 1 Withdraw the dipstick, wipe it clean and push fully home again before withdrawing it for reading.
- 2 Add oil via the filler cap until the level reaches the 'High' mark on the dipstick.  
**DO NOT OVERFILL** and ensure that the dipstick and filler cap are replaced.

##### (2) Check/top up cooling system

**WARNING:** Do NOT remove cooling system filler caps or plugs when engine is hot.

- 1 Slowly turn the pressure cap anti-clockwise until the resistance of the safety stop is felt. Leave the cap in this position until all pressure is released. Press the cap downwards against the spring to clear the safety stops and continue turning until it can be lifted off.
- 2 Maintain the level of the coolant in the expansion tank at half full by topping up as necessary whilst the system is up cool.

**NOTE:** Ensure that the specific gravity of the coolant is maintained - see 'LUBRICANTS, FLUIDS AND FUEL'.

##### (3) Check/adjust operation of all washers & top up reservoirs.

- 1 Replenish the container with clean soft water. The addition of a small amount of mild detergent will prevent smearing on the windscreen.
- 2 During freezing conditions it is beneficial to fill the container with a mixture of one part methylated spirits (wood alcohol) to two parts of water. This will assist in the dispersal of snow and ice from the screen.
- 3 Do not add anti-freeze solutions to the container as this will discolour the paintwork and damage wiper blades and sealing rubber.

##### (4) Renew engine oil

**NOTE:** This operation is best carried out when the engine is warm and with the vehicle standing level on a ramp or over a pit.

To drain the sump, unscrew the drain plug three complete turns to direct the oil stream into a receptacle while the engine is warm. When the rate of flow lessens, remove the plug completely. Refit the plug and refill the sump with the appropriate grade of engine oil. The use of additives is unnecessary.

##### (5) Renew oil filter element

See 12.60.01 and 12.60.02.

##### (6) Lubricate accelerator linkage/pedal pivot - check operation

###### Lubricate

Using an oil can, lubricate the accelerator linkage on the carburetter and the accelerator pedal pivot. Wipe away any surplus oil to avoid drips or any possibility of staining the carpet inside the car.

###### Check operation

Check carburetter throttle response to initial movement of the accelerator pedal. If required, adjust the throttle cable at the carburetter.

Check carburetter throttle position with accelerator pedal fully depressed, by observing that the carburetter lever(s) move to a positive stop.

If the throttle movement is not satisfactory, investigate the cause and rectify as necessary, proceeding in the following order.

Check that the throttle pedal movement is not restricted by floor mats or carpet etc. Check the carburetter lever(s) for correct position and settings - see 19.15.01 or 19.15.02, as applicable.

Check the throttle cable location and condition - see 19.20.06.

##### (7) Check cooling/heater systems for leaks and hoses for security and condition

- 1 Check for leaks from engine and radiator drain taps/plugs (where fitted).
- 2 Check for leaks from water hose joints.
- 3 Check for leaks from water hoses through damage or porosity.
- 4 Check for leaks from the water pump thermostat housing, radiator and heater unit.
- 5 Report any leaks found.

##### (8) Check for oil leaks

Report any found.

##### (9) Check/adjust torque of cylinder head nuts/bolts

See 12.29.27.

##### (10) Check driving belts, adjust or renew

Check condition where belt is visibly worn or damaged. Fit new belt if necessary.

Check and adjust:

- a Alternator drive belt - see 86.10.05.
- b Air pump drive belt - see 17.25.13.
- c Compressor drive belt (where applicable) - see 82.10.01.

**(11) Check security of engine mountings**  
Check the security of the following engine fixings using the data in 'TORQUE WRENCH SETTINGS'.

- 1 Inlet manifold and exhaust manifold.
- 2 Cam cover.
- 3 Air cleaner and carburetters.
- 4 Air pump.
- 5 Sump.
- 6 Timing cover.
- 7 E.G.R. valve.
- 8 Engine and gearbox mountings.
- 9 Alternator.

**(12) Check/adjust carburetter idle settings**  
See 19.15.01 or 19.15.02, as applicable.

**(13) Top up carburetter piston damper(s)**

- 1 Release the two toggle clips securing the outer section of the air cleaner housing.
- 2 Pivot the outer section about the hot air intake hose to gain access to the air cleaner element. Take care that the air intake control vacuum pipe is not disturbed.
- 3 Remove the carburetter damper assembly from the carburetter by unscrewing the hexagonal plug in top of the carburetter.
- 4 Raise the piston by inserting a finger into the carburetter air intake hole. With the piston raised top up the hollow damper guide with a recommended engine oil, until the oil level is  $\frac{1}{4}$ " (6 mm) below the top of the guide.
- 5 Release the piston and refit the damper assembly, screwing down the plastic plug.
- 6 To ensure correct location of the oil retaining cup in the damper guide, again raise and lower the piston.

**NOTE:** A certain amount of pressure will be left when lifting the piston, but it is essential that the piston is lifted to its maximum height to ensure correct location of the oil retaining cup.

**(14) Renew carburetter/air intake air cleaner element**  
See 19.10.08.

**(15) Check/adjust deceleration by-pass valve**  
See 19.15.01 or 19.15.02, as applicable.

**(16) Check security of E.G.R. valve operating lines**

Check E.G.R. valve operating pipe lines for security of push fit connections at the following units:

- a E.G.R. valve.
- b Cut-off valve.
- c Tee-piece (Canada only).
- d Fuel trap.
- e Carburetter.

Renew any pipes that show signs of deterioration.

**(17) Check E.G.R. system**

- 1 Disconnect the vacuum pipe from the top of the E.G.R. valve.
- 2 Remove the two bolts securing the E.G.R. valve to the inlet manifold and withdraw the valve.
- 3 Clean the base of the valve with a wire brush.
- 4 Use a standard spark plug machine to clean the valve seat and pintle. Insert the valve opening into the machine and lift the diaphragm evenly by using two fingers. Blast the valve for approximately 30 seconds, remove the inspect. If necessary, repeat until all carbon deposits are removed. Use compressed air to remove all traces of carbon grit from the valve.
- 5 Examine the E.G.R. ports in the manifold. Light deposits are not detrimental to system function and should not be disturbed. Heavy deposits must be cleared by removing the inlet manifold and cleaning the ports.

**CAUTION:** Do not attempt to clean the ports with the manifold in position.

- 6 Using a new gasket, refit the E.G.R. valve and two securing bolts.
- 7 Reconnect the vacuum pipe to the top of the E.G.R. valve.
- 8 Check E.G.R. valve operating lines for security of push fit connections at E.G.R. valve, cut-off valve, tee-piece, fuel trap and carburetter. Renew any pipes that show signs of deterioration.

**9 Check function of E.G.R. valve as follows:**

- Start and run the engine until normal operating temperature is attained. Ensure that the choke control knob is pushed fully in. Open and close the throttle several times and observe or feel the E.G.R. valve, which should open and close with the changes in engine speed. The valve should close instantly when the throttle is closed.
- 10 If the operation of the valve does not appear completely satisfactory, check the valve by connecting the vacuum pipe of a distributor vacuum test unit to the valve. Ensure that the valve is actuated, held, and that there is no leak of vacuum, otherwise, fit a new E.G.R. valve complete.

**(18) Check air intake temperature control system, excluded on catalytic converter vehicles**

See 17.30.01.

**(19) Check crankcase breathing and evaporative loss system hoses for security**

- 1 Visually check the following hoses for security, and rectify as necessary.
  - 2 Crankcase purge line.
  - 3 Carburetter float chamber vent pipe.
  - 4 Adsorption canister purge line.
  - 5 Fuel tank vent pipe.
  - 6 Manifold vacuum line.

**(20) Check breathing and evaporative loss systems**

Check hoses and restrictors for blockage, security and condition.

- 1 Inspect all hoses illustrated, items 2 to 6, for condition and renew any hoses that show signs of deterioration, including slackness or cracking.
- 2 Completely disconnect the crankcase purge line and the adsorption canister purge line, illustration items 2 and 4, then using a low pressure air supply, blow through these hoses to check for blockage. Investigate and clear any blockage, paying particular attention to the restrictors fitted at points 'A' and 'B'.
- 3 Refit the purge lines, ensuring that all connections are secure and tight. Renew any doubtful hose.

**(21) Check air injection system, hoses pipes for security and condition**

**(22) Check/top up air conditioning compressor fluid**

**(23) Renew adsorption canister**  
See 17.15.13.

**(24) Renew Catalytic converter Excluded on Non Catalytic Converter Vehicles**

See 17.50.01.

Reset Catalytic Converter service interval indicator, using special key.

**IGNITION**

**(25) Check security of distributor vacuum unit line and operation of vacuum unit (California and Canadian Market only)**

- 1 Check security of distributor vacuum unit operating line connections at carburetter, fuel trap and distributor.
- 2 Start the engine and warm it to normal running temperature.
- 3s When the engine is idling steadily, disconnect the vacuum unit pipe at the distributor.
- 4 A noticeable rise in engine speed (approximately 500 rev/min) should be apparent if the vacuum unit is functioning.
- 5 When satisfied that the vacuum unit is operating correctly, reconnect the vacuum unit pipe to the distributor, ensuring a secure connection.

**(26) Lubricate distributor**

- 1 Remove the distributor cap and rotor arm. Using an oil can, apply three drops of a clean, recommended engine oil into the reservoir in the rotor carrier.
- 2 Remove flash-over shield and lubricate pick-up centre bearing plate with a drop of the same oil in each of the two holes provided. DO NOT disturb the screw securing the base plate. Refit the flash-over shield.

**(27) Check/adjust ignition timing using electronic equipment**  
See 86.35.15.



**(28) Check ignition wiring for fraying, chafing and deterioration****Low tension circuit**

- 1 Check connections of the ballast resistor wire, drive resistor, distributor, coil and ignition switch.
- 2 Check ignition coil connections.
- 3 Check wiring between coil and distributor.
- 4 Check distributor external connections.
- 5 Remove distributor cap and check internal wiring.
- 6 Check distributor internal connections.
- 7 Refit distributor cap.

**High tension circuit.**

- 8 Check lead between coil and distributor.
- 9 For each spark plug in turn: Check lead between plug and distributor.
- 10 Check high tension lead connections.
- 11 Report wiring condition.

**(29) Clean distributor cap, check for cracks and tracking**

- 1 Using a nap-free cloth, wipe the distributor cap and rotor arm clean. Inspect the cap and rotor, internally and externally, for cracks and any trace of tracking.
- 2 Refit the rotor arm and cap if serviceable, otherwise, fit new components as necessary.

**(30) Renew spark plugs****For each plug in turn**

- 1 Withdraw ignition high tension lead from plug.
- 2 Unscrew plug from engine using a special plug spanner or a suitable tube spanner.
- 3 Discard the plug.
- 4 Visually check new plug for damage to body and electrodes, discard plug if damaged.
- 5 Check electrode gap on new plug, which when correct, will just allow a 0.0025 in (0,64 mm) feeler gauge to slide slowly between the electrodes under light pressure.

- 6 If adjustment is necessary, using a suitable tool, carefully move the side electrode. Recheck the gap and repeat this procedure until the gap is correct.
- 7 Check sealing washer for cracks and distortion, and renew washer if necessary.
- 8 Fit new spark plug to engine.
- 9 Tighten plug to 20 lbf ft (2,8 kgf m).
- 10 Refit the high tension lead to the plug.

**(31) Check coil performance on oscilloscope**

- 1 Using proprietary electronic testing equipment, in accordance with the equipment instructions, check the resistance of the ignition coil primary winding, which must be 1.2 to 1.5 ohms. If necessary, fit a new ignition coil.

**TRANSMISSION****(32) Check/top up gearbox oil**

- 1 With the vehicle standing in a level position, remove the oil level/filler plug and, using a suitable dispenser filled with the correct grade oil, see 'LUBRICANTS & ANTI-FREEZE SOLUTIONS', top up the gearbox until the oil is level with the bottom of the filler hole threads.
- 2 Allow surplus oil to drain away, then refit the filler plug and wipe clean.

**(33) Check/top up rear axle/final drive oil**

- 1 With the vehicle standing in a level position, remove the oil level/filler plug and top up the final drive unit with the correct grade of oil, see 'LUBRICANTS & ANTI-FREEZE SOLUTIONS', until the oil is level with the bottom of the filler hole threads. Allow surplus oil to drain away, then refit the filler plug and wipe clean.

**(34) Check for oil leaks**

Report any found.

**(35) Check tightness of propeller shaft coupling bolts**

Refer to 'TORQUE WRENCH SETTINGS' for data.

**(36) Check/top up automatic gearbox fluid**  
Refer to 'LUBRICANTS & ANTI-FREEZE SOLUTIONS' for recommended fluids.**(37) Lubricate automatic gearbox exposed selector linkage****(38) Check clutch pipes for leaks and chafing**

Report any found

**(39) Check/top up clutch fluid reservoir****(40) Lubricate clutch pedal pivots****STEERING AND SUSPENSION****(41) Check steering rack/for oil/leaks**

Report any found

**(42) Check security of suspension fixings**  
Refer to 'TORQUE WRENCH SETTINGS' for data.**(43) Check condition and security of steering unit joints and gaiters**

Refer to 'TORQUE WRENCH SETTINGS' for data, report any defects found.

**(44) Check/adjust front wheel alignment**

See 57.65.01.

**(45) Adjust front hub bearing end float**

- 1 Remove road wheel.
- 2 Check hub for end float.
- 3 If adjustment is required, remove hub cap and split pin.
- 4 Tighten slotted nut as required to eliminate end float. A torque of 5 lbf ft (0,691 kgf m) must not be exceeded or damage may be caused to bearings and bearing tracks. Slacken nut to permit entry of split pin.
- 5 Insert and lock split pin.
- 6 Clean hub cap and refit.
- 7 Fit road wheel.

**(46) Lubricate steering rack and pinion**

- 1 Wipe clean the plug and surrounding area.
- 2 Remove the plug.
- 3 Fit a suitable grease nipple in place of the plug.
- 4 Apply a grease gun, filled with the correct grade of grease, see 'LUBRICANTS & ANTI-FREEZE SOLUTIONS', to the grease nipple and give five strokes only.  
**CAUTION:** Over-greasing can cause damage to the protective bellows.
- 5 Remove the grease nipple.
- 6 Refit the plug.
- 7 Wipe away any surplus grease.

**(47) Check shock absorbers for fluid leaks**  
Report any found.**BRAKES****(48) Inspect brake pads for wear and discs for condition**

- 1 Jack up the front of the car and place safely onto stands before removing the disc pads (see 70.40.02).

**CAUTION:** Do NOT depress the brake pedal while the pads are removed.

- 2 Report pad condition if the friction lining has been reduced to 0.125 in (3 mm) or if there is not sufficient material to provide a thickness of 0.125 in (3 mm) at the completion of a further 3,000 miles (5,000 km) motoring.
- 3 Check the brake discs for excessive scoring and run out and report this if present.

**(49) Inspect brake lining/pads for wear, drums/discs for condition**

- 1 Jack up the car and place safely onto stands before removing the road wheel (held by 4 nuts) and the brake drum (see 70.10.03).
- 2 Check the brake linings for wear and report if they are excessively worn, damaged or contaminated by oil or grease. Remove surplus oil or grease and any brake lining dust before replacing the brake drum.
- 3 For discs see Maintenance Operation 48 for front pads and disc inspection.

**(50) Check/top up brake fluid reservoir**

Top up when required with new fluid of the correct type recommended — see 'LUBRICANTS & ANTI-FREEZE SOLUTIONS.' Do not allow the fluid level to drop below the danger mark on the reservoir.

**WARNING:** Use only new brake fluid of the correct specification. DO NOT use fluid of unknown origin, or fluid that has been exposed to the atmosphere, or discharged during bleeding operations. If significant topping is required, check the hydraulic system for leaks.

**CAUTION:** Paintwork can be damaged by direct contact with brake fluid.

**(51) Check footbrake operation, adjust to manufacturers instructions (self adjusting)**

- 1 With the handbrake off, check the brake pedal for spongy operation.
- 2 If the pedal has spongy operation, bleed and adjust the brakes, see 70.25.01.

**(52) Check handbrake operation; adjust to manufacturers instructions**

- 1s If the handbrake travel is excessive, adjust the handbrake, see 70.35.10.

**(53) Lubricate brake pedal pivot**

- 1 Using an oil can, lubricate the brake pedal pivot.
- 2 Wipe away the surplus oil to prevent staining the carpet.

**(54) Lubricate handbrake mechanical linkage and cable guides**

- 1 Smear grease around the handbrake compensator, working it well into the clevis pins.
- 2 Smear grease around the rear brake-drum clevis pins.
- 3 Grease all exposed sections of the inner cable to resist corrosion.

**(55) Check visually, hydraulic pipes and unions for chafing, leaks and corrosion**

**(56) Check brake servo hoses for security and condition.**

**ELECTRICAL**

**(57) Check function of original equipment, i.e. interior and exterior lamps, horns, wipers and warning indicators**

In sequence, check operation of:

- 1 Side, tail and headlamps (including dip/main beam and 'Flash' control) also number plate illumination lamp.
- 2 Instrument panel illumination.
- 3 Interior light(s).
- 4 Horns.
- 5 Auxiliary lights.  
With ignition circuits energised check operation of:
  6. All warning lights.
  7. Fuel level indicator.
  8. Heater blower motor.
  9. Windscreen washers.
  10. Windscreen wipers.
  11. Direction indicators.
  12. Brake lights.
  13. Reversing lights.
- 14 Start engine and note that the oil pressure warning has extinguished.  
Check operation of:
  - 15 Charging system warning light in relation to engine speed.
  - 16 Temperature indicator.
  - 17 Switch off the engine and return the ignition switch to the auxiliary position, then re-check the function of any fitted accessories e.g. a radio, that are supplied with power from this switch position.
- 18 Report any defects found.

**(58) Check/top up battery electrolyte**

Using DISTILLED WATER ONLY top up; the electrolyte level is correct when it just covers the separators.

**(59) Clean and grease battery connections**

- 1 Check the battery and surrounding area for corrosion from battery chemicals.
- 2 Clean off any corrosion found.
- 3 Check visually for any cracks in the battery case and report on any case cracks found.
- 4 Check security of terminal connections.
- 5 Coat terminals with petroleum jelly.

**(60) Check/adjust headlamp alignment**

See 86.40.17.

**(61) Check, if necessary renew wiper blades**

- 1 Examine each wiper blade in turn for damage before wetting the windscreen and operating the wiper motor control.
- 2 Replace wiper blades if they are damaged or if the screen is smeared.

**(62) Check output of charging system**

**EXHAUST AND FUEL PIPES**

**(63) Check exhaust system for leaks and security**

- 1 Check security of exhaust pipe to manifold nuts, correct tightening torque is 30 to 37 lbf ft (4,2 to 5,1 kgf m).
- 2 Check security of exhaust pipe joint clips.
- 3 Check security of exhaust system mounting bolts.
- 4 Using a second operator, run engine at fast idle speed.
- 5 Check exhaust system joints for leaks. Check exhaust pipes for leaks arising from damage or deterioration.
- 6 Check exhaust silencers for leaks arising from damage or deterioration.
- 7 Stop engine.
- 8 Report any defects found.

**(64) Check fuel system for leaks, pipes and unions for chafing and corrosion**

Report any defects found.

**(65) Check conditions of fuel filler cap seal**

- 1 Make a visual check of the seal for the fuel tank filler cap.
- 2 Renew the seal if its condition is doubtful.

**WHEELS AND TYRES**

**(66) Check/adjust tyre pressures including spare**

Refer to Driver's Handbook for pressure settings.

**(67) Check that tyres comply with manufacturers specification**

See Driver's Handbook.

Report any deviations that may influence the car's performance or the accuracy of the speedometer.

**(68) Check tightness of road wheel fastenings**

Refer to 'TORQUE WRENCH SETTINGS' for data.

**(69) Check tyres for external cuts in tyre fabric, exposure of ply or cord structure, lumps or bulges**

**(70) Check tyres for tread depth and visually for external cuts in fabric, exposure or ply or cord structure, lumps or bulges.**

**WARNING**

It can be dangerous

- a To use a car fitted with tyres in a damaged condition.
- b To mix cross ply and radial ply tyres on the same axle or to fit radial ply tyres to the front wheels only.
- c To use a car fitted with tyres that have a tread depth of less than 0.039 in (1.0 mm) over three-quarters of the tread width for the entire circumference of the tyre.
- d To use a car with the tyres inflated to a pressure that is not suitable for the use to which the vehicle is put.

If the tyres do not conform with legal requirements report to the owner.

**BODY**

**(71) Lubricate all locks and hinges (not steering lock)**

**(72) Check condition and security of seats and seat belts**

**(73) Check rear view mirror for cracks and crazing**

**(74) Check operation of all door, bonnet and boot locks**

(75) Check operation of seat belt warning system

(76) Check operation of seat belt inertial reel mechanism

(77) Check operation of window controls

(78) Check tightness of subframe/body mountings

Refer to 'TORQUE WRENCH SETTINGS' for data.

(79) Ensure cleanliness of controls, door handles, steering wheel

#### GENERAL

(80) Road/roller test and check function of all instrumentation

(81) Report additional work required

## PREVENTIVE MAINTENANCE

In addition to the recommended periodical inspection of brake components it is advisable as the car ages and as a precaution against the effects of wear and deterioration to make a more searching inspection and renew parts as necessary.

It is recommended that:

- 1 Disc brake pads, drum brake linings, hoses and pipes should be examined at intervals no greater than those laid down in the Maintenance Summary Chart.
- 2 Brake fluid should be changed every 18 months or 19,000 miles whichever is the sooner.
- 3 All fluid seals in the hydraulic system should be renewed and all flexible hoses should be examined and renewed if necessary every 3 years or 37,500 miles whichever is the sooner. At the same time the working surface of the piston and of the bores of the master cylinder, wheel cylinders and other slave cylinders should be examined and new parts fitted where necessary.

Care must be taken always to observe the following points:

- a At all times use the recommended brake fluid.
- b Never leave fluid in unsealed containers. It absorbs moisture quickly and can be dangerous if used in your braking system in this condition.
- c Fluid drained from the system or used for bleeding should be discarded.
- d The necessity for absolute cleanliness throughout cannot be overemphasized.

#### Replacing brake shoes

When it becomes necessary to renew the brake-shoes, it is essential that only genuine shoes, with the correct grade of lining, are used. Always fit new shoes as complete sets, never individually or as a single wheel set. Serious consequences could result from out-of-tolerance braking due to the mixing of lining.

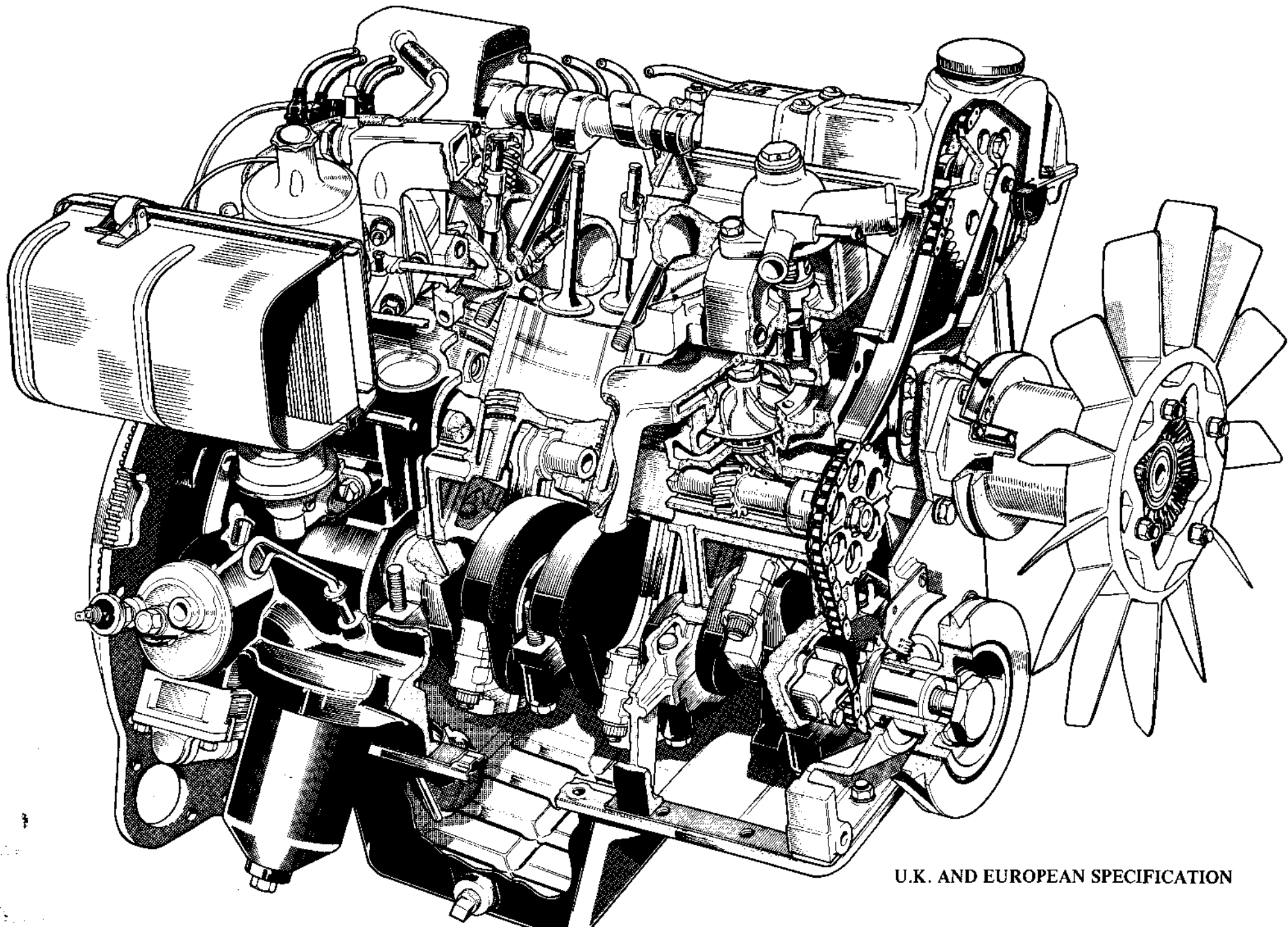

U.K. AND EUROPEAN SPECIFICATION

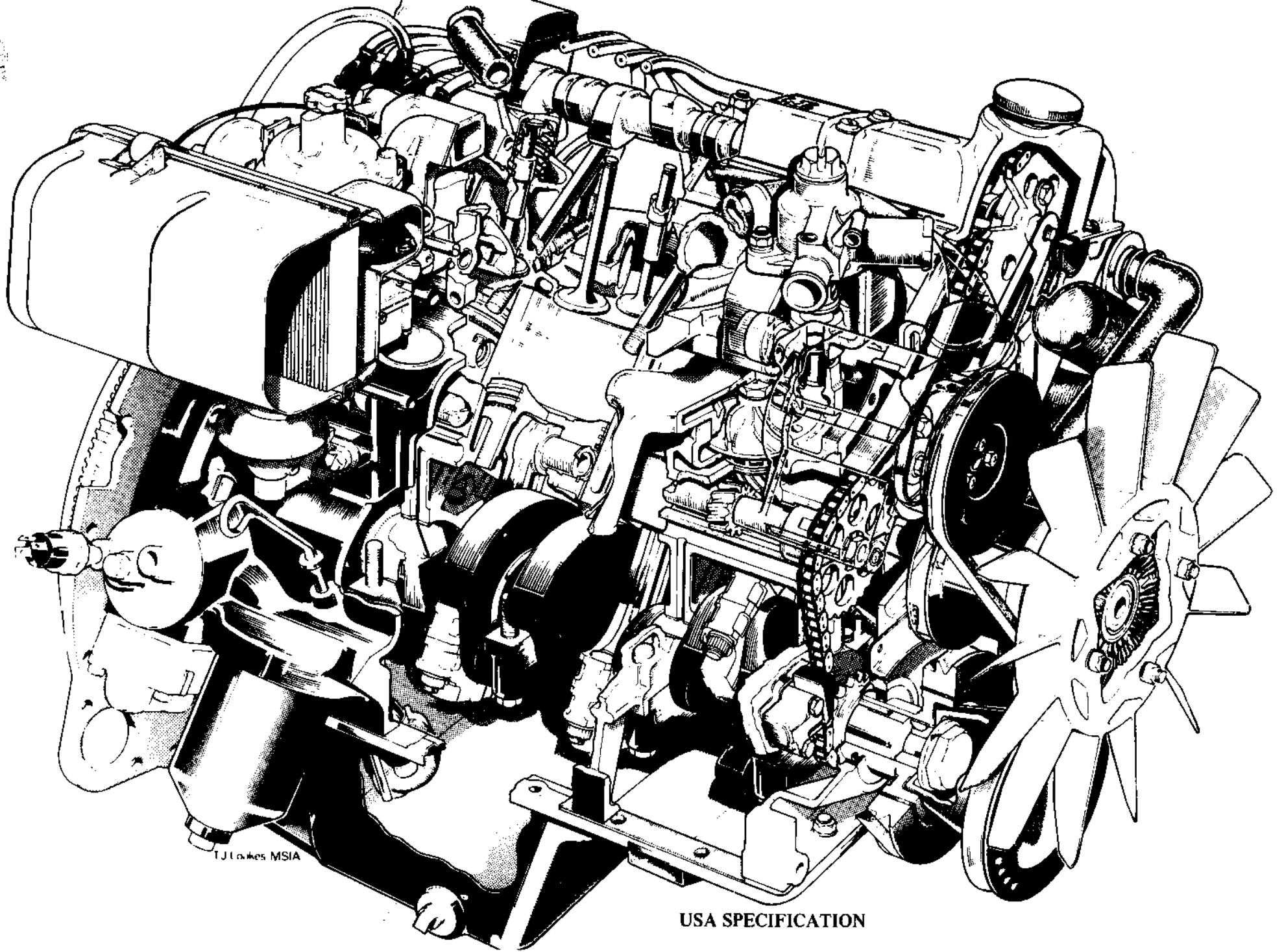

TJ Loves MSIA

USA SPECIFICATION

## JACKSHAFT

Remove and refit 12.10.14

### Removing

- 1 Disconnect the battery.
- 2 Remove the fresh air duct. 80.15.31.
- 3 Remove the radiator. 26.40.01.
- 4 Remove the air conditioning condenser 82.15.10 (if fitted).
- 5 Remove the timing cover. 12.65.01.
- 6 Remove the inlet manifold complete with carburettors. 19.15.15.
- 7 Remove the water pump cover. 26.50.01.
- 8 Remove the impeller. 26.50.01.
- 9 Remove the petrol pump. 19.48.08.
- 10 Remove the camshaft cover. 12.29.42.
- 11 Turn the engine over so that the timing mark on the camshaft flange is in line with the groove on the camshaft front bearing cap.
- 12 Remove the distributor cap and check that the rotor arm points to the last manifold bolt hole in the cylinder head thus indicating that the engine is at T.D.C. number one cylinder firing.
- 13 Remove the distributor.
- 14 Remove the hydraulic timing chain tensioner. 12.65.28.

- 15 Remove the adjustable timing chain guide. 12.65.50.
- 16 Remove the two Allen screws and withdraw the jackshaft keeper plate.
- 17 Lift the timing chain clear of the sprocket and withdraw the jackshaft complete with the sprocket.
- 18 Hold the jackshaft in a vice and remove the sprocket retaining bolt, tab washer and sprocket.

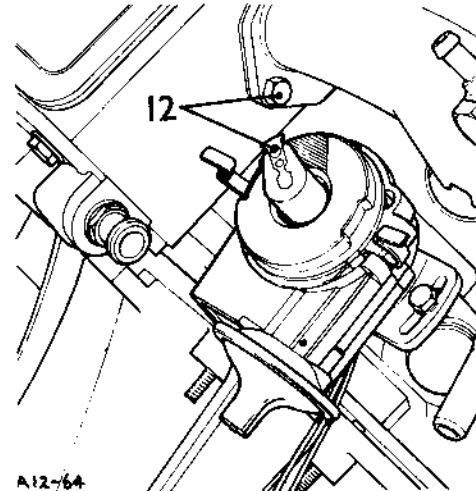

USA Specification

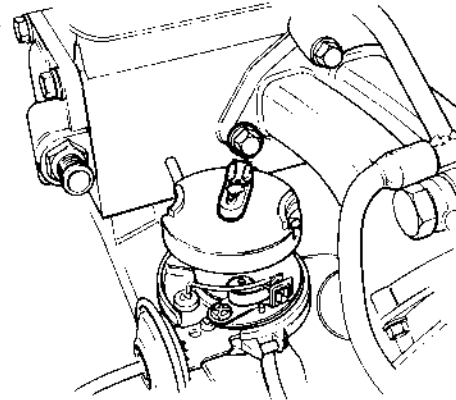

UK and Europe Specification

### Refitting

- 19 Fit the sprocket to the jackshaft using a new tab washer.
- 20 Insert the jackshaft into the cylinder block and secure with the keeper plate and two Allen screws.
- 21 Turn the jackshaft so that the scribed line across the sprocket is equidistant between the lower bolt securing the camshaft sprocket support bracket and the timing cover centre retaining bolt hole. Fit the chain whilst holding the jackshaft in this position.
- 22 Fit the adjustable chain guide and leave the bolt slack.
- 23 Fit the hydraulic timing chain tensioner 12.65.28 instructions 7 to 19.
- 24 Fit the petrol pump ensuring that the lever rides on top of the jackshaft cam.
- 25 Fit the water pump impeller and cover - instructions 9 to 14. 26.50.01.
- 26 Fit the distributor and line-up the rotor as in instruction 12 and check the timing. 86.35.15.
- 27 Fit the timing chain cover. 12.65.01.
- 28 Fit the camshaft cover.

- 29 Fit the air conditioning condenser 82.15.10.
- 30 Fit the radiator. 26.40.01.
- 31 Fit the inlet manifold complete with carburettors. 19.15.15.
- 32 Fit the fresh air duct. 80.15.31.
- 33 Check that the cooling system has been filled and connect the battery.

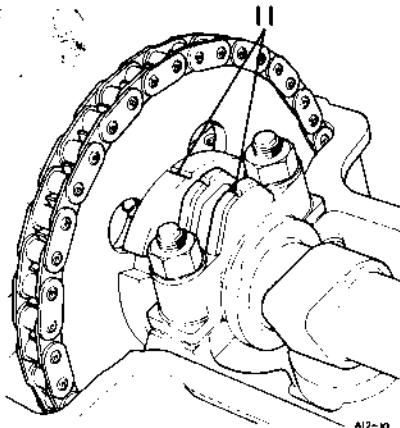
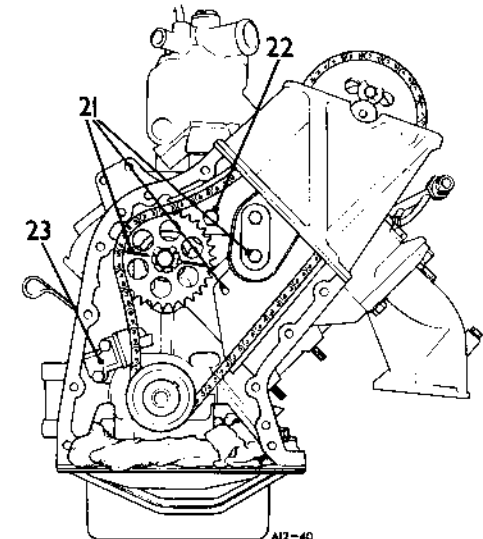
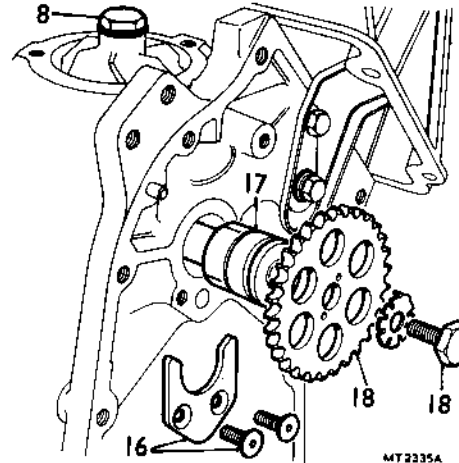

## CAMSHAFT

Remove and refit

12.13.01

### Removing

- 1 Disconnect the battery.
- 2 Remove the fresh air duct. 80.15.31.
- 3 Remove the camshaft cover. 12.29.42.
- 4 Turn the engine over so that the timing mark on the camshaft flange is 180° distant from the groove in the camshaft front bearing cap to gain access to the lower bolt.
- 5 Anchor the camshaft sprocket to the support bracket using a 'slave' nut.
- 6 Unlock and remove the exposed camshaft sprocket lower retaining bolt.
- 7 Turn the engine over so that the timing mark on the camshaft flange is exactly in line with the groove in the camshaft front bearing cap.
- 8 Unlock and remove the remaining sprocket retaining bolt and lock washer.
- 9 Evenly slacken-off the ten camshaft bearing cap nuts and remove them complete with plain washers.
- 10 Check that the bearing caps are numbered for identification i.e. starting at the front of the engine, number one is recognized by the timing grooves and the remainder are numbered 2 to 5.
- 11 Withdraw the caps and remove the camshaft.

### Refitting

- 12 Clean and lubricate the camshaft journals and corresponding bearings in the cylinder head and fit the camshaft.
- 13 Lubricate and fit the bearing caps in their correct order.

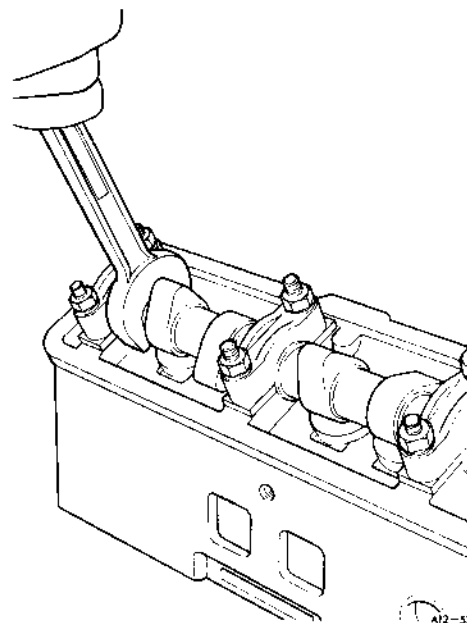
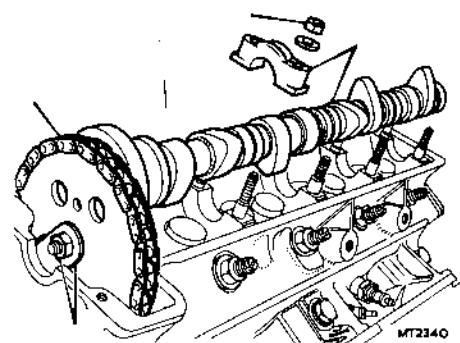
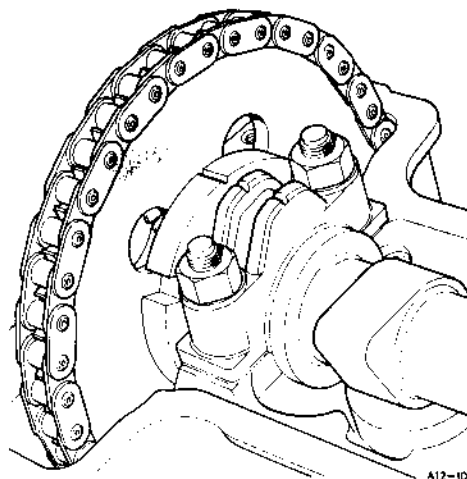
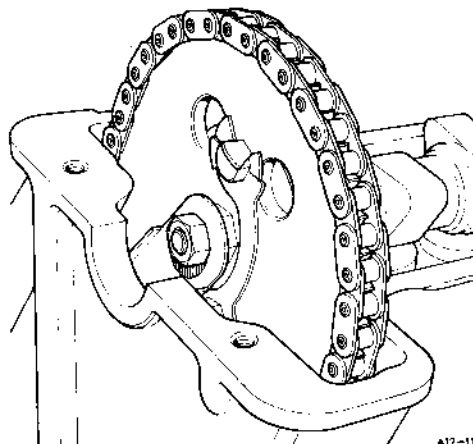

**CAUTION:** Before commencing instruction 14 ensure that the timing mark on the camshaft flange is approximately in line with the groove in the front bearing cap to avoid damage being caused to the pistons by the valve heads.

- 14 Fit and tighten the bearing cap nuts and washers evenly to the correct torque figure – see section 06.

**NOTE:** At this stage in the operation the valve clearances may be checked if desired – see 12.29.48 but it is vital that before doing so the crankshaft is turned 90° so that the pistons are not at T.D.C. and therefore not in danger of being damaged by the valve heads.

- 15 Finally adjust the position of the camshaft timing mark in relation to the groove in the front bearing cap by turning the shaft by means of a spanner on the hexagon at the rear of the shaft.
- 16 Secure the camshaft sprocket to the camshaft using a new lock washer – do not at this stage fully tighten or lock the bolt.
- 17 Turn the engine over so that the remaining bolt may be fitted.
- 18 Tighten both bolts to the correct torque figure – see section 06 and bend over the lock tabs.
- 19 Remove the 'slave' nut holding the sprocket to the support bracket.
- 20 Fit the semi-circular sealing rubber to the cylinder head.
- 21 Fit the camshaft cover. 12.29.42.
- 22 Fit the fresh air duct. 80.15.31.
- 23 Reconnect the battery.

## CONNECTING RODS AND PISTONS

Remove and refit 12.17.01

Special tool: 38 U3.

**CAUTION:** Do not mix any components during this operation.

### Removing

- 1 Drive the car onto a ramp and disconnect the battery.
- 2 Remove the inlet manifold complete with carburetters. 19.15.15.
- 3 Remove the cylinder head. 12.29.10.
- 4 Remove the sump. 12.60.44.
- 5 Check the identification numbers on the connecting rods and caps.
- 6 Turn the crankshaft to bring numbers 1 to 4 pistons to T.D.C. and remove the nuts of numbers 2 and 3 connecting rods.

- 7 Withdraw the bearing caps and lower shells and fit plastic or rubber sleeves over the connecting rod bolts to prevent damage to the crankpins.
- 8 Push the piston and connecting rod assemblies upwards and withdraw through the top of the bores and remove the upper shells.
- 9 Turn the crankshaft to bring numbers 1 and 4 connecting rod bolts to an accessible position and remove the nuts and withdraw the bearing caps and lower shells.
- 10 Push the piston and connecting rod assemblies upwards and withdraw as instruction 8.

### Refitting

- 11 Stagger the piston ring gaps.
- 12 Lubricate the pistons and rings and compress the rings with special tool number 38 U3.
- 13 Insert the connecting rod and piston assemblies into their respective bores ensuring that the raised flat part of the piston crown and the valve head recesses are towards the right-hand side of the engine (as from the driver's side of the engine).

**NOTE:** Some pistons may have arrows stamped on both sides of the skirt, on the gudgeon pin bore side, to indicate the direction of the gudgeon pin off-set. Ensure that when fitting the piston assemblies to the bores that these arrows point to the right-hand side of the engine also. Alternatively some pistons may have an arrow on the crown and the piston assemblies must be fitted with the arrow pointing to the front of the engine.

- 14 Fit the upper bearing shells to the connecting rods ensuring that the keeper tags locate correctly in the connecting rod recesses.
- 15 Fit the lower bearing shells to the caps ensuring that the keeper tags locate in the recesses.
- 16 Pull the connecting rods onto the crankpins and fit the bearing caps to their respective connecting rods making sure that the identification numbers coincide and are adjacent. Note also that the bearing keeper recesses in the connecting rods and the caps are on the same side.
- 17 Secure the bearing caps with NEW nuts and tighten evenly to the correct torque — see 'TORQUE WRENCH SETTINGS'.
- 18 Fit the oil sump. 12.60.44.
- 19 Fit the cylinder head. 12.29.10.
- 20 Fit the inlet manifold complete with carburetters. 30.15.02.
- 21 Refill the sump with the recommended grade of oil to the high mark on the dip-stick.
- 22 Refill the cooling system. 26.10.01
- 23 Reconnect the battery.

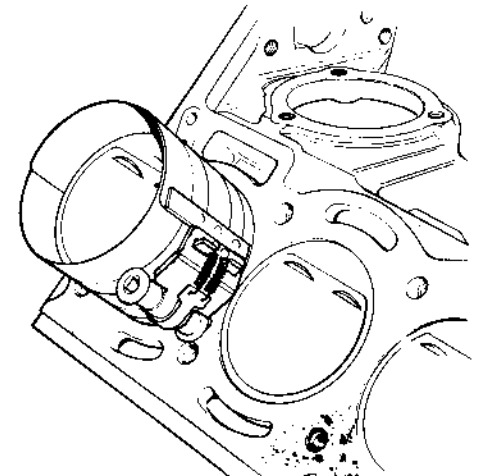
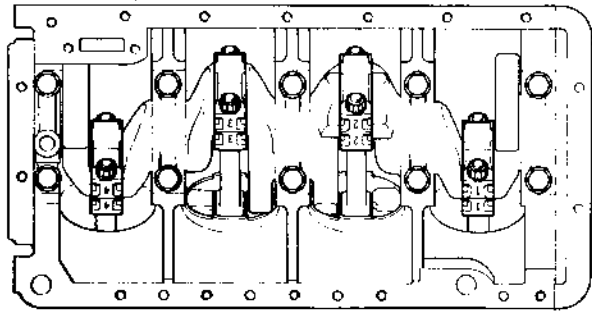
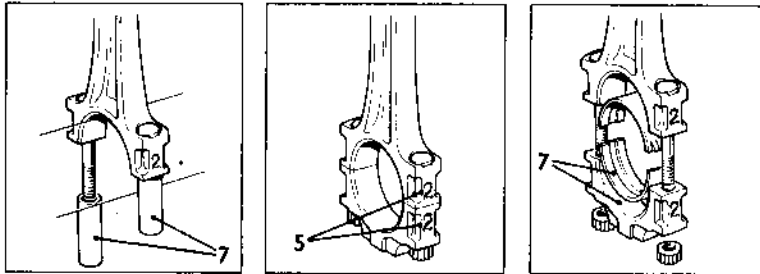



**CONNECTING RODS AND PISTONS**

Overhaul	12.17.10
Gudgeon pin bush – each – – remove and refit	12.17.13

Special tool: 335

**CAUTION:** Do not mix the components during this operation.**Removing**

- 1 Remove the connecting-rods and pistons. 12.17.01.

**Dismantling**

- 2 Remove the two gudgeon pin retaining circlips.
- 3 Push out the gudgeon pin and separate the piston from the connecting-rod.
- 4 Remove the top, scraper and oil control rings.
- 5 Repeat instructions 2 to 4 on the remaining pistons and connecting-rod assemblies.
- 6 De-grease all components and remove carbon deposits from the pistons.

**Examination – Pistons and Gudgeon Pins**

- 7 Examine the pistons for damage, scoring and cracks.
- 8 Determine the maximum clearance that exists between the pistons and their respective bores as follows:
  - a Measure the piston across the skirt – dimension A – at right angles to the gudgeon pin.
  - b Using a cylinder bore measuring gauge determine the maximum cylinder bore wear.
  - c Subtract (a) from (b) and compare the result with the clearance given in data for a new engine.

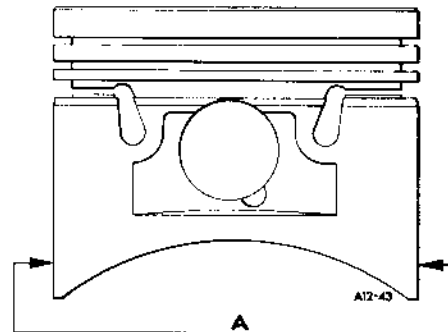
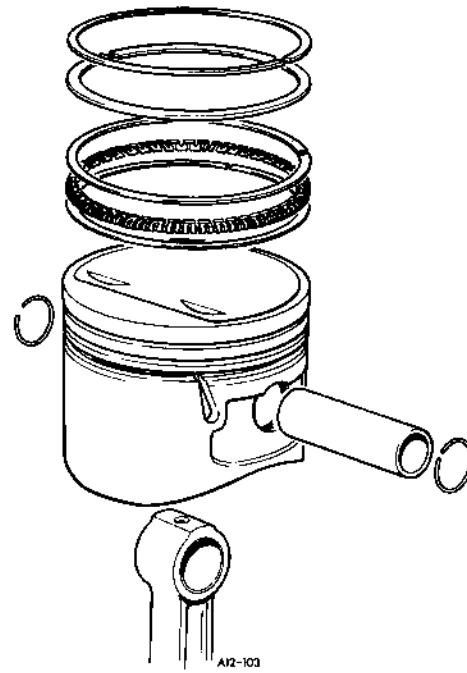

- 9 Check the dimension of the piston ring grooves and the gap between the piston ring and groove – see DATA.
- 10 Examine the gudgeon pin for scores and pitting. Check for wear – see data. The gudgeon pin should be a thumb push fit in the piston at a temperature of 68 F.
- 11 Check the top and scraper piston ring gaps when inserted squarely into the bores – see DATA.

**NOTE:** Two grades of standard piston designated F and G are fitted to new engines built on production. The cylinder block is stamped on the L.H. side as illustrated to indicate the individual bore grade. The grade of the corresponding piston is stamped on the crown.

Whilst these pistons are not supplied for service purposes, a single standard piston 0.001 in (0,0254 mm) oversize is available. Therefore should it be necessary to fit a new piston to a standard bore, the bore must be honed to accommodate the piston with the specified clearance – see DATA.

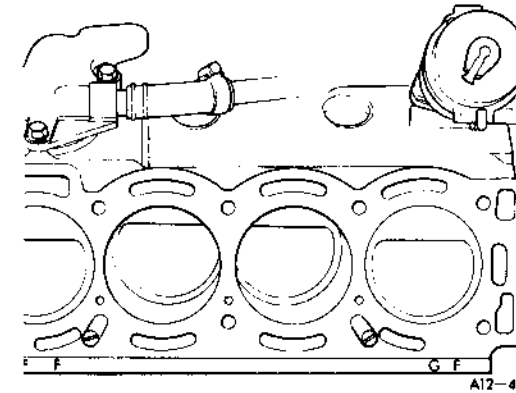
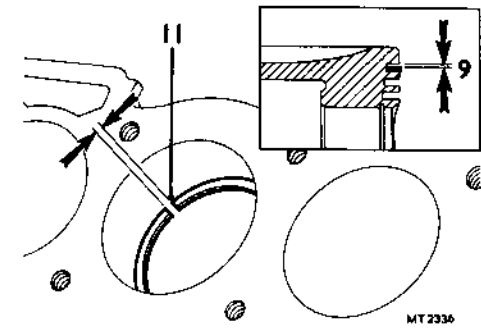
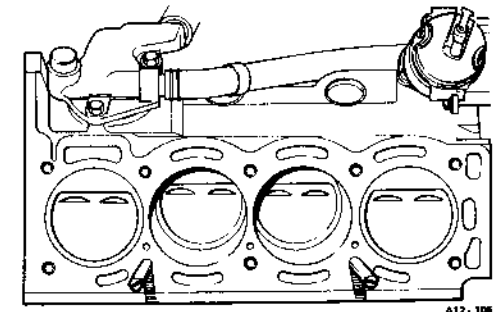
**USA Specification****UK & Europe Specification**

**Examination – Connecting-rods**

12 Using special tool 335 check the connecting-rods for:

- A. Bend
- B. Twist.

Rods that exceed the tolerances in data should be realigned or renewed.

13 Check the gudgeon pin bush for wear and if necessary remove the old bush and fit a new one using a suitable press. Ensure that the oil hole in the bush corresponds exactly with the hole in the connecting-rod. Ream the new bush to size – see DATA.

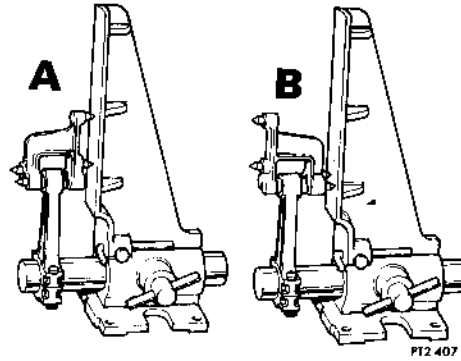

**Reassembling**

14 Fit the piston rings in the following order:

**NOTE:** The oil control ring comprises three parts, A, B and C, namely the centre expander rail, flanked by two identical chrome rails.

- A. Fit the expander rail into the bottom groove ensuring that the ends butt, not overlap.
- B. Fit the bottom chrome rail to the bottom groove.
- C. Fit the top chrome rail to the bottom groove.
- D. Fit the scraper ring to the centre groove in the piston with the word 'TOP' uppermost.
- E. Fit the top compression chrome ring to the top groove.

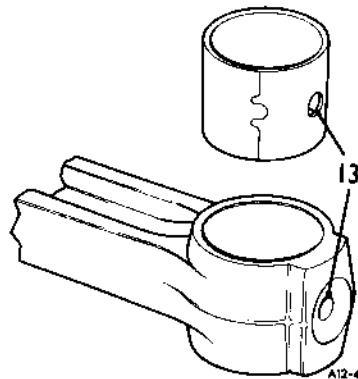
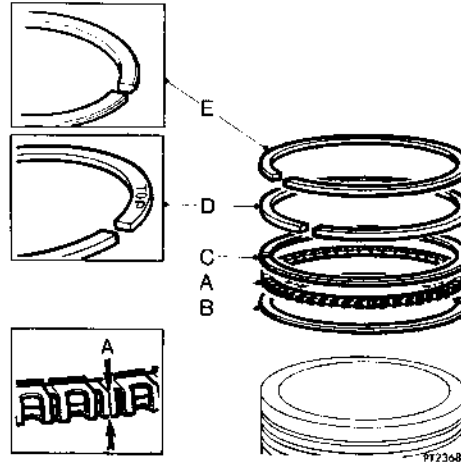

- 15 Refit the pistons to the connecting-rods so that the identification numbers and the shell bearing keeper recesses are on the opposite side to the raised part of the piston crown.
- 16 Locate the gudgeon pin with the two circlips ensuring that they fit properly in the grooves.
- 17 Fit the connecting-rods and pistons to the engine – instructions 10 to 21 12.17.01 ensuring that the sump is refilled with oil to the high mark on the dipstick.
- 18 Refill the cooling system before connecting the battery.



**DATA**

Cylinder bore size	3.56 in (90,3 mm)
Piston clearance in bore measured at bottom of skirt at right angles to the gudgeon pin	0.0005 to 0.0015 in (0,013 to 0,039 mm)

**Pistons**

Top compression ring groove width	0.0705 to 0.0713 in (1,790 to 1,810 mm)
Second compression ring groove width	0.0700 to 0.0709 in (1,780 to 1,800 mm)
Oil control ring groove width	0.1579 to 0.1587 in (4,010 to 4,020 mm)

**Piston rings**

Top compression – gap in bore	0.015 to 0.025 in (0,40 to 0,65 mm)
Top compression – clearance in groove	0.0019 to 0.0039 in (0,050 to 0,082 mm)
Second compression ring – gap in bore	0.015 to 0.025 in (0,40 to 0,65 mm)
Second compression ring – clearance in groove	0.0015 to 0.0025 in (0,040 to 0,065 mm)
Oil control rails – gap in bore	0.015 to 0.055 in (0,40 to 1,40 mm)
Oil control expander – gap in bore	ends to butt
Oversize rings	0.010 to 0.020 in (0,254 to 0,508 mm)

**Connecting rods**

Small end bush fitted internal diameter	0.9377 to 0.9380 in (23,818 to 23,825 mm)
Bush external diameter	1.0015 to 1.0025 in (25,438 to 25,464 mm)

## CONNECTING ROD BEARINGS

Remove and refit – set	12.17.16
– one	12.17.17
– extra each	12.17.18

## Removing

- 1 Drive the car onto a ramp.
- 2 Disconnect the battery.
- 3 Drain the sump oil, and remove the dipstick.
- 4 Remove the sump. 12.60.44.
- 5 Turn the engine until numbers 1 and 4 big-end bearings are in an accessible position.
- 6 Check that the connecting-rods and caps are numbered correctly.

**CAUTION:** Do not mix components whilst carrying out the following instructions.

- 7 Remove the two special nuts securing each big-end cap and withdraw the caps complete with lower shells.

- 8 Push the connecting rod upwards sufficiently to enable the upper shell bearing to be removed.
- 9 Fit rubber or plastic sleeves over the big-end bolts to prevent damage being caused to the crankpins.
- 10 Turn the crankshaft sufficiently to bring numbers 3 and 4 big-end bearings to an accessible position.
- 11 Repeat instructions 6 to 9 on numbers 2 and 3 big-ends.

## Refitting

- 12 Clean numbers 2 and 3 crankpins and corresponding bearings and caps.
- 13 Fit the upper bearing shell to the connecting-rod ensuring that the keeper tag locates in the connecting-rod recess and pull the rod onto the crankpin.
- 14 Fit the lower bearing shell to the cap ensuring that the keeper tag locates correctly in the connecting-rod recess.

- 15 Remove the protective sleeves from the connecting-rod bolts and fit the bearing cap checking that:
  - a The correct number cap is being fitted to the connecting-rod concerned.
  - b The keeper tags are adjacent – i.e. on the same side of the bearing.
- 16 Fit and evenly tighten new nuts to the correct torque figure – see 'TORQUE WRENCH SETTINGS'.
- 17 Turn the crankshaft to bring numbers 1 and 4 big-ends to an accessible position.
- 18 Repeat instructions 12 to 18 on numbers 1 and 4 big-ends.
- 19 Fit the sump. 12.60.44.
- 20 Lower the ramp and fill the sump to high mark on the dipstick with oil of a recommended grade.
- 21 Reconnect the battery.
- 22 Drive the car from the ramp.

- 10 Secure the pulley with the special bolt and washer, and tighten to the correct torque figure – see 'TORQUE WRENCH SETTINGS'.
- 11 Lower the ramp, fit and tension the drive belt.
- 12 Put the gear lever in the 'neutral' position and re-connect the battery and drive the car off the ramp.

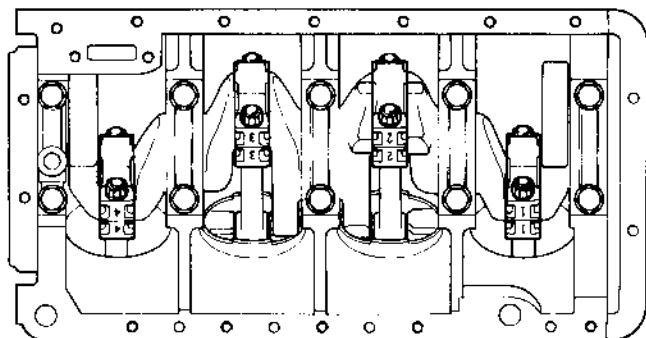
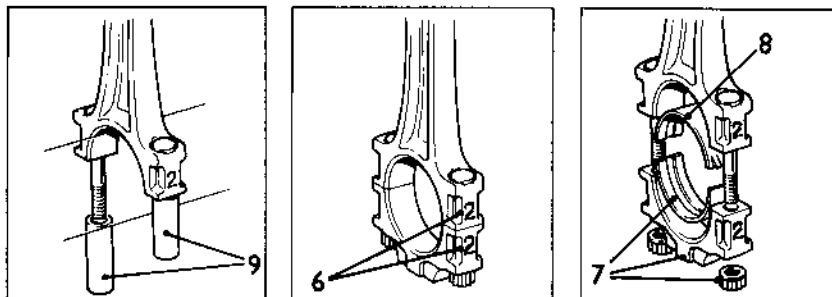

PT220

## CRANKSHAFT PULLEY

Remove and refit 12.21.01

## Removing

- 1 Drive the car on to a ramp.
- 2 Disconnect the battery.
- 3 Slacken the alternator drive belt tension and slip it from the crankshaft pulley.
- 4 Place the car in gear and put the handbrake 'on'.
- 5 Raise the ramp.
- 6 Turn the special bolt – securing the pulley – to the crankshaft – anti-clockwise and remove together with the washer.
- 7 Withdraw the crankshaft pulley.

## Refitting

- 8 Ensure the key is in position in the crankshaft.
- 9 Lubricate the crankshaft and fit the pulley.

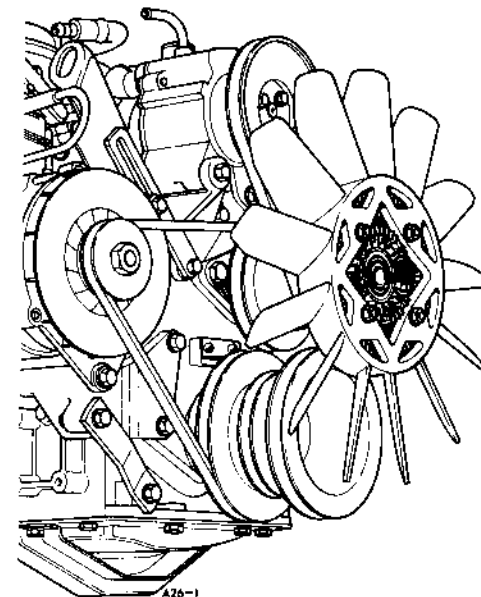

A16-1

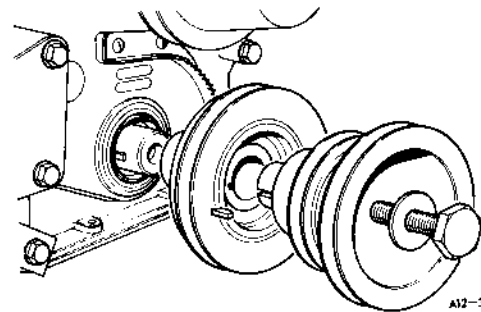

A12-3

## CRANKSHAFT PULLEY AND AUXILIARY DRIVES – USA Specification

Remove and refit 12.21.02

### Removing

- 1 Drive the car onto a ramp, and disconnect the battery.
- 2 Remove the fan blades. 26.25.06.
- 3 Slacken the compressor adjustment bolts, and slip the belt from the pulley, see operation 82.10.02 instructions 1 to 3.
- 4 Slacken the alternator – fan drive belt adjustment bolts and release the belt from the pulley.
- 5 Place the car in gear and put the hand brake on.
- 6 Raise the ramp.
- 7 Remove the special bolt and washer securing the pulleys to the crankshaft.
- 8 Withdraw the auxiliary pulley cluster.
- 9 Remove the crankshaft pulley.

### Refitting

- 10 Lubricate the crankshaft pulley boss and fit it to the crankshaft locating on the crankshaft key.
- 11 Fit the auxiliary pulley cluster locating on the crankshaft key.
- 12 Secure the assembly with the special bolt and washer and tighten to the correct torque figure see section 06.
- 13 Lower the ramp and put the gear lever in neutral.
- 14 Fit the alternator – fan drive belt and adjust the tension see operation 86.10.05 instructions 4 to 7.
- 15 Fit the compressor drive belt to the pulleys and adjust the tension see operation 82.10.01 instructions 7 to 11 and lower ramp.
- 16 Refit the fan blades 26.25.06 instructions 6 to 8.
- 17 Reconnect the battery and remove the car from ramp.

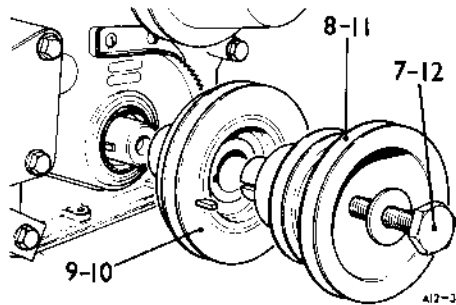
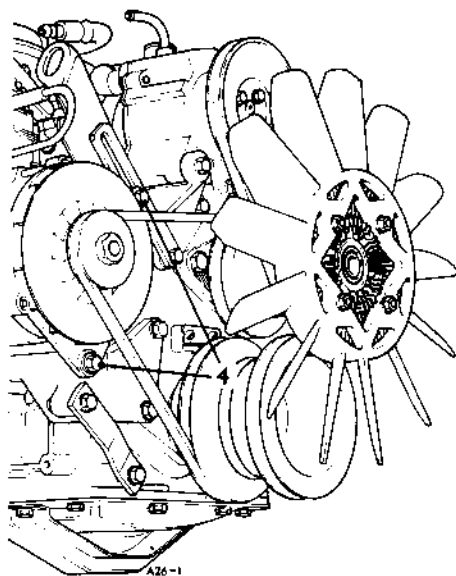

## CRANKSHAFT REAR OIL SEAL

Remove and refit 12.21.20

### Removing

- 1 Drive the car onto a ramp.
- 2 Disconnect the battery.
- 3 Remove the gearbox. 37.20.01.
- 4 Remove the clutch. 33.10.01.
- 5 Remove the flywheel. 12.53.07.
- 6 Remove the two rear sump bolts.
- 7 Slacken the two rear-most R.H. side sump bolts.
- 8 Slacken the L.H. side sump rear-most nut and bolt.
- 9 Remove the six bolts securing the crankcase oil seal housing to the crankcase.
- 10 Press out the oil seal from the housing.

### Refitting

- 11 Lubricate the outer diameter of a new seal and press it squarely into the housing so that the lip faces the crankshaft.
- 12 Clean the crankcase and seal housing mating faces and using sealing compound fit a new gasket.
- 13 Lubricate the crankshaft and carefully ease the seal into position locating the housing on the two dowels.
- 14 Fit the six housing retaining bolts loosely noting that the two lower opposing bolts are longer.
- 15 Evenly tighten the bolts to the correct torque figure – see section 06.
- 16 Fit and tighten the two rear sump to seal bolts.
- 17 Tighten the R.H. side sump bolts.
- 18 Tighten the L.H. side nuts and bolts.
- 19 Fit the flywheel.
- 20 Fit the clutch assembly. 33.10.01.
- 21 Fit the gearbox. 37.20.01.
- 22 Reconnect the battery and remove the car from ramp.

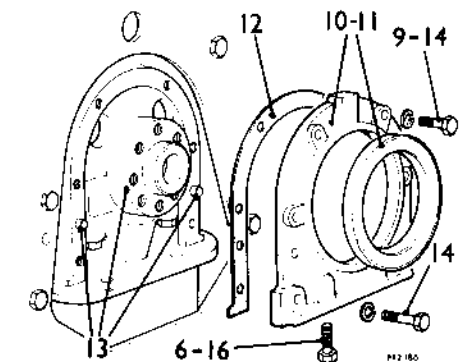
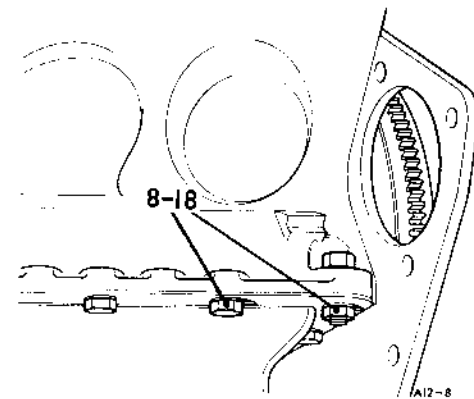
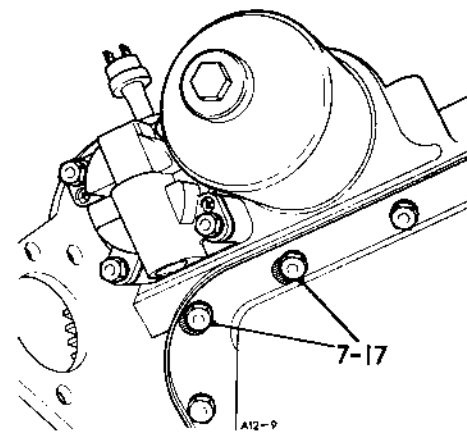

# CRANKSHAFT END-FLOAT

Check and adjust 12.21.26

## Checking

- 1 Raise the car on a ramp.
- 2 Disconnect the battery.
- 3 Attach the magnetic base of a dial gauge stand to the underside of the sump and arrange the dial gauge so that the stylus rests in a loaded condition on the front face of the crankshaft pulley.
- 4 Lever the crankshaft rearwards.
- 5 Zero the dial gauge and lever the crankshaft forward and note the reading.
- 6 Repeat instructions 4 and 5 several times until a constant reading is achieved – see DATA.
- 7 Remove the dial gauge and magnetic base.

## Adjusting

- 8 Drain the sump oil and remove the dipstick.
- 9 Remove the sump. 12.60.44.
- 10 Remove two bolts and withdraw number 3 main bearing cap and lower shell.
- 11 Using the blade of a thin screwdriver and taking care not to damage the crankshaft, remove the two crankshaft thrust bearings.

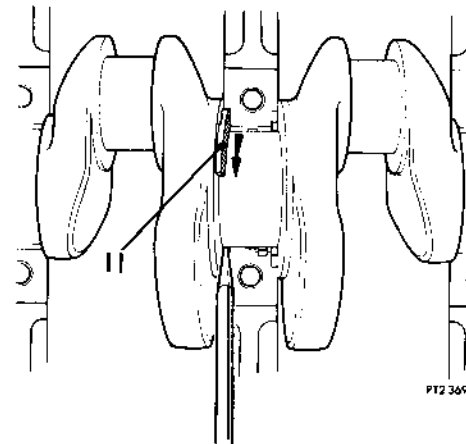
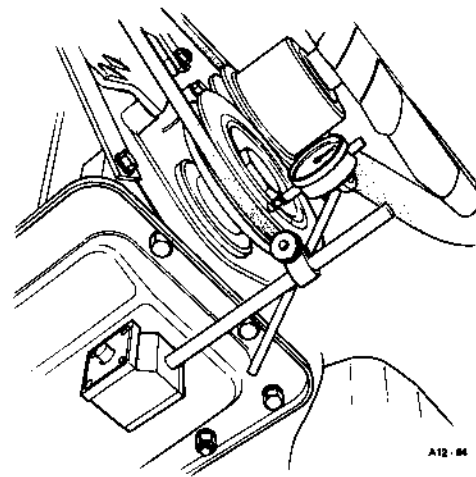

- 12 Lubricate and feed the thrust bearings of the appropriate size into the channel, reversing the method of removal. Ensure however, that the two grooves in the thrust bearing face outwards away from the bearing cap.
- 13 Fit the main bearing cap and lower shell noting that the keeper recesses in the cap and crankcase are adjacent. Temporarily tighten the two retaining bolts.
- 14 Using a feeler gauge or clock gauge check the crankshaft end-float by levering the crankshaft forwards or rearwards.
- 15 Repeat instructions 10 to 14 if necessary to achieve the correct end-float.
- 16 Finally tighten the number 3 main bearing cap bolts to the correct torque figure – see section 06.
- 17 Refit the sump. 12.60.44.
- 18 Refill the sump to the high mark on the dipstick with oil of a recommended grade.
- 19 Lower the car.
- 20 Connect the battery.

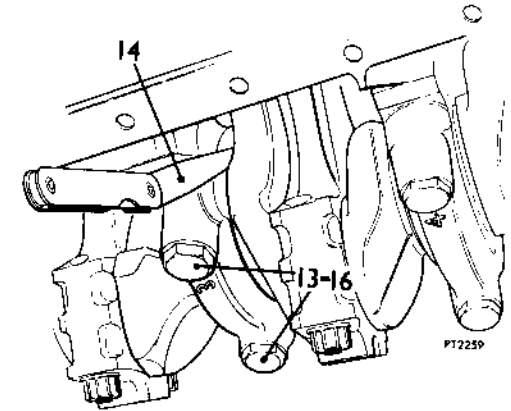
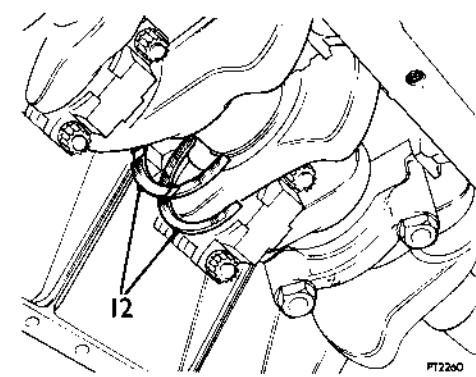

## DATA

Crankshaft end-float . . . . .	0.003 to 0.011 in (0,07 to 0,28 mm)
Adjustment . . . . .	By selective thrust bearings 0.005 in (0,127 mm)

## CRANKSHAFT

Remove and refit 12.21.33

### Removing

- 1 Remove the engine and gearbox assembly from the car. 12.37.01.
- 2 Drain the sump.
- 3 Remove the gearbox, noting the position of the remaining bell housing bolts to assist refitting.
- 4 Remove the clutch.
- 5 Remove the flywheel - 12.53.07 instructions 4 to 6.
- 6 Remove the engine rear adaptor plate.
- 7 Remove the sump, and dipstick.
- 8 Remove the crankshaft rear main oil seal - 12.21.20 instruction 9.
- 9 Remove the timing chain cover - 12.65.01
- 10 Remove the oil pick-up strainer.
- 11 Remove the oil thrower.
- 12 Remove the crankshaft sprocket.
- 13 Remove the drive key and shims.
- 14 Remove the connecting rod bearing caps and lower shells, and push the pistons up the bores just sufficiently to clear the crankshaft journals. 12.17.16.

- 15 Fit plastic or rubber sleeves over the connecting rod bolts to prevent damage to the crankshaft journals.
- 16 Remove the timing chain 12.65.14 instructions 2 to 15.
- 17 Remove the ten bolts retaining the main bearing caps.
- 18 Withdraw the five main bearing caps and lower shells.
- 19 Lift out the crankshaft.
- 20 Remove the spigot bush.
- 21 Remove the upper shells and thrust washers from the crankcase.

### Refitting

- 22 Fit the upper shells to the crankcase ensuring that the keepertags locate in the recesses.
- 23 Fit the thrust washers to number three main bearing noting that the grooves face outwards.
- 24 Clean and lubricate the main bearing journals and lower the crankshaft into the crankcase.

- 25 Clean and fit the main bearing shells to the caps ensuring that the keeper tags locate in the cap recesses.
- 26 Fit the main bearing caps to the crankcase partially tightening the securing bolts and ensuring that the caps are fitted to their correct crankcase bearings.
- 27 Check the crankshaft end-float - see Data - by inserting a feeler gauge between the crankshaft and the thrust washers in number three bearing, see 12.21.26 instruction 14, or using a dial gauge.
- 28 Tighten the ten main bearing bolts to the correct torque.
- 29 Clean and lubricate the crankshaft journals, pull the connecting rods and upper shells onto the journals and remove the protective sleeves from the bolts.
- 30 Clean and fit the connecting rod caps ensuring:
  - a The caps are fitted to their correct connecting rods.
  - b The keeper tags in the rods and caps are adjacent.
  - c The nuts are tightened to the correct torque.
- 31 Temporarily fit the crankshaft sprocket and check its alignment with the jackshaft sprocket using a straight-edge across the two sprockets. Adjust by fitting shims between the crankshaft and sprocket.
- 32 Check that the timing mark on the camshaft flange is in line with the groove on the camshaft front bearing cap.

**CAUTION:** While the timing chain is disconnected do not allow the pistons to reach T.D.C. otherwise damage to the valves and pistons may result.

*continued*

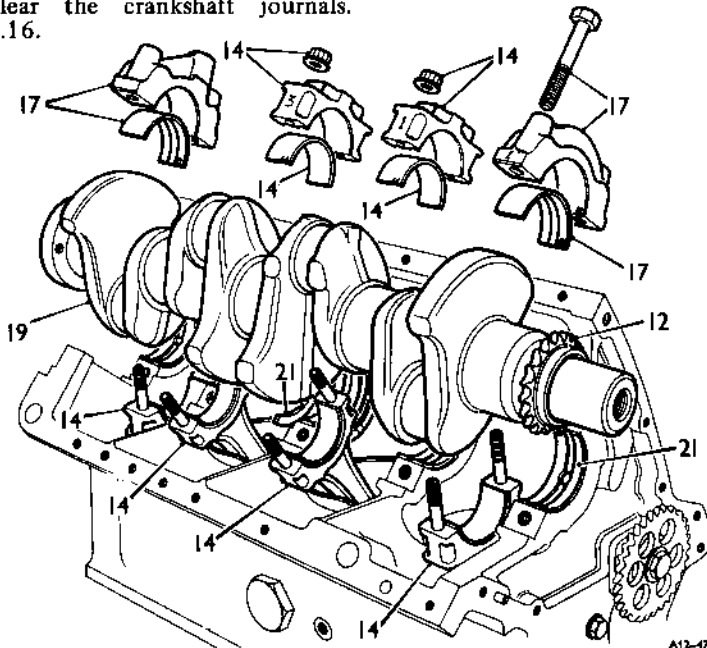

A12-47

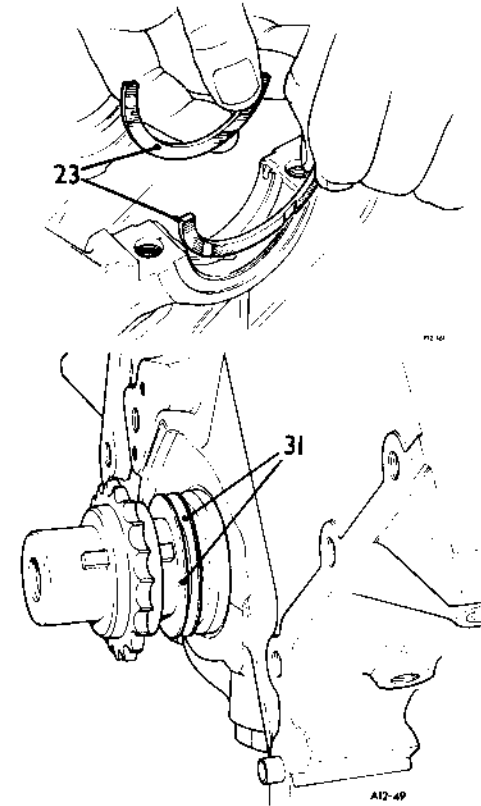

A12-49

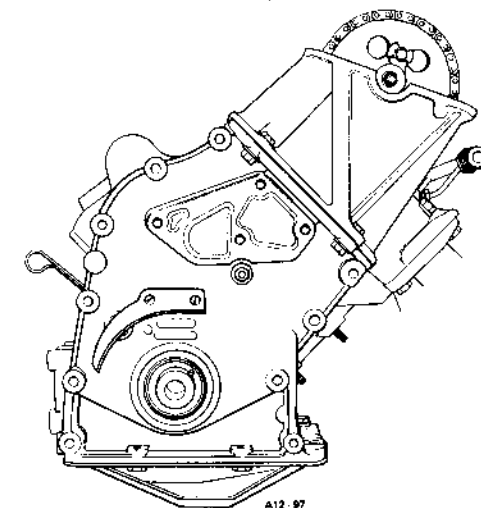

A12-97

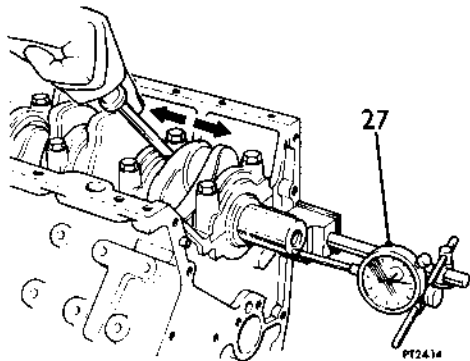

- 33 Fit the timing chain. 12.65.14.
- 34 Fit the oil thrower - dished face outwards.
- 35 Using a new gasket fit the timing chain cover locating it over the dowels. Secure with the centre retaining bolt, noting that it has a fibre washer under the head.
- 36 Fit the two nuts and bolts securing the timing cover to the cylinder head.
- 37 Fit the crankshaft pulley.
- 38 Fit the fan pulley assembly.
- 39 Fit the alternator mounting bracket. 12.25.21.

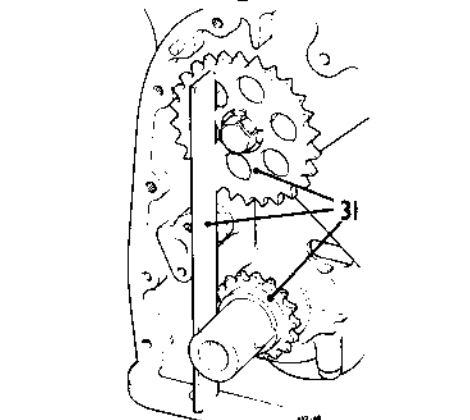

- 40 Fit the alternator and drive belt and adjust the tension. 86.10.02.
- 41 Fit a new crankshaft rear main oil seal 12.21.20 instructions 11 to 15.
- 42 Fit the engine rear adaptor plate 12.53.03 instructions 6 and 7.
- 43 Fit the oil pick-up strainer.
- 44 Fit the sump and dipstick.
- 45 Fit the spigot bush.
- 46 Fit the flywheel 12.53.07 instructions 7 to 11.
- 47 Fit the clutch. 33.10.01.
- 48 Fit the gearbox.
- 49 Fit the engine and gearbox to the car. 12.37.01.

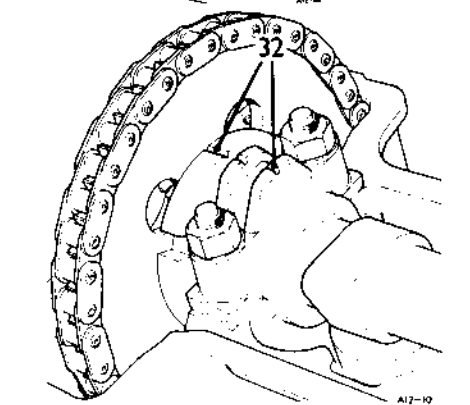

- 50 Fill the sump with oil of a recommended grade to the high mark on the dipstick.
- 51 Fill the cooling system. 26.10.01.
- 52 Connect the battery.
- 53 Check and if necessary adjust the ignition timing. 86.35.15.

**DATA**

Main bearing journal diameter .....	2.1260 to 2.1265 in (54,000 to 54,013 mm)
Crankpin diameter .....	1.7500 to 1.7505 in (44,450 to 44,463 mm)
Minimum re-grind diameter	
- main bearings .....	2.0860 to 2.0865 in (52,984 to 52,997 mm)
- crankpins .....	1.7100 to 1.7105 in (43,434 to 43,447 mm)

**MAIN BEARINGS**

- Remove and refit - set 12.21.39
- Remove and refit - each 12.21.40

**Removing**

- 1 Drive the car on to a ramp.
- 2 Disconnect the battery.
- 3 Drain the oil sump and remove the dipstick.
- 4 Remove the sump. 12.60.44.

**CAUTION:** It is important that during the following instructions the bearing caps, shells and bolts are not mixed but are kept identified with their respective bearings. It

will be noted that the bearing caps are numbered 1 to 5 commencing at the front of the engine.

- 5 Remove the two bolts securing the bearing cap to the crankcase.
- 6 Withdraw the bearing cap complete with the lower shell.
- 7 With the tag end leading, carefully slide the upper shell bearing out from between the crankshaft journal and crankcase.
- 8 Remove the lower shell bearing from the bearing cap.
- 9 Repeat instructions 5 to 8 on the remaining bearings.

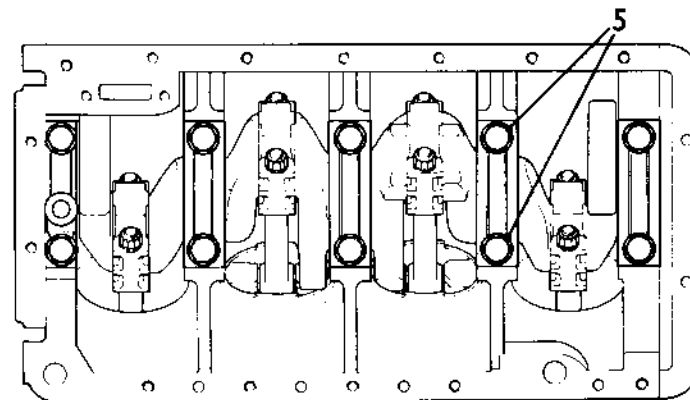
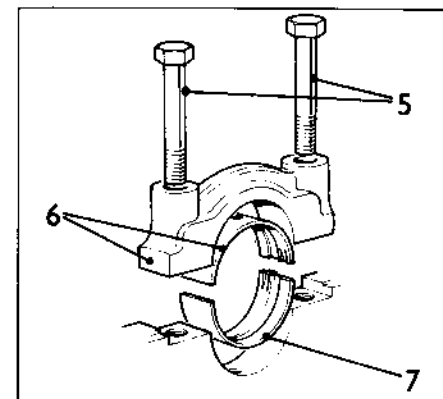
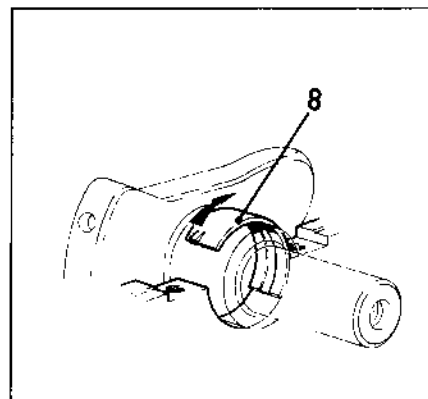

P12221

### Refitting

- 10 Lubricate with clean engine oil all bearing shells.
- 11 With the tag end trailing, feed the upper shell bearing between the crankshaft journal and the crankcase. Ensure that the keeper tag locates properly in the crankcase recess.
- 12 Fit the lower shell bearing into the bearing cap ensuring that the keeper tag locates correctly in the cap recess.
- 13 Fit the cap to the crankcase noting that the keeper tag is fitted adjacent to its counterpart in the crankcase.
- 14 Secure the cap with the bolts and tighten evenly to the correct torque figure – see 'TORQUE WRENCH SETTINGS'.
- 15 Repeat instructions 11 to 14 on the remaining bearings.
- 16 Check and if necessary adjust the crankshaft end-float. 12.21.26.
- 17 Fit the sump. 12.60.44.
- 18 Lower the ramp and fill the sump with oil of a recommended grade to the high mark on the dipstick.
- 19 Reconnect the battery.
- 20 Drive the car from the ramp.

### SPIGOT BUSH

Remove and refit 12.21.45

#### Removing

- 1 Remove the gearbox. 37.20.01.
- 2 Remove the clutch assembly. 33.10.01.
- 3 Remove the eight flywheel retaining bolts.
- 4 Remove the spigot bush retaining plate.
- 5 Withdraw the spigot bush.

#### Refitting

- 6 Insert the spigot bush into the crankshaft bore.
- 7 Fit the spigot bush retaining plate and the eight flywheel retaining bolts and tighten to the correct torque figure – see 'TORQUE WRENCH SETTINGS'.
- 8 Refit the clutch assembly. 33.10.01.
- 9 Refit the gearbox. 37.20.01.

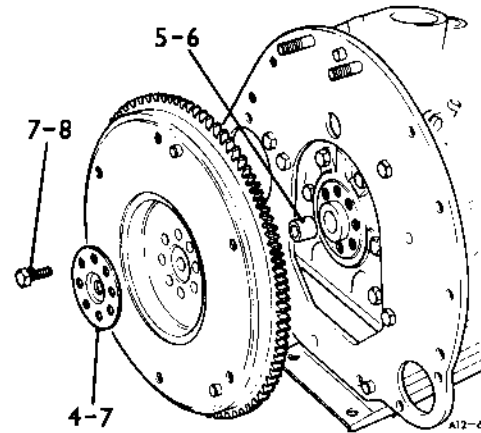

### CYLINDER BLOCK DRAIN PLUG

Remove and refit 12.25.07

#### Removing

**WARNING:** This operation must only be carried out when the engine is cold.

- 1 Drive the car onto a ramp and disconnect the battery.
- 2 Raise the ramp and using a long extension with a universal joint and socket remove the drain plug slowly to allow the coolant to drain.
- 3 Remove the plug completely when the coolant flow lessens.

#### Refitting

- 4 Reverse instructions 1 to 3, using a new washer.

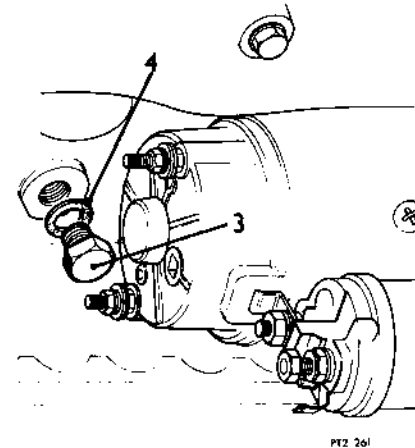



**ALTERNATOR CARRIER BRACKET**

Remove and refit 12.25.21

**Removing**

- 1 Disconnect the battery.
- 2 Remove the alternator. 86.10.02.
- 3 Remove the four bolts securing the carrier bracket to the engine.
- 4 Remove the support strap from the bracket.

**Refitting**

- 5 Secure the bracket to the engine with the two front bolts.
- 6 Fit the rear bolt ensuring that the correct thickness of washer is used between the bracket and engine.
- 7 Fit the support strap.
- 8 Refit the alternator and tension the belt. 86.10.02.
- 9 Reconnect the battery.

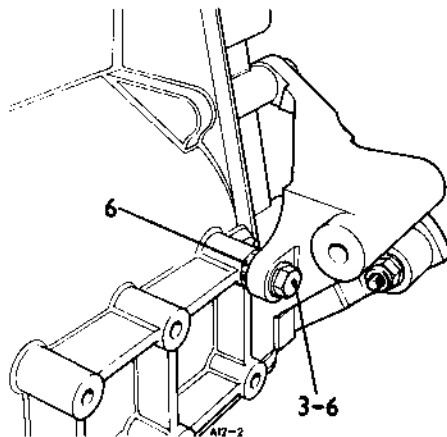
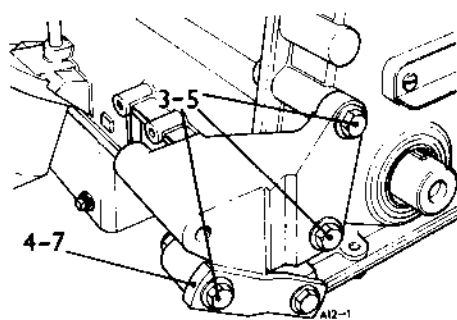

**CYLINDER HEAD GASKET – UK and Europe Specification**

Remove and refit 12.29.02

**Removing**

- 1 Drive the car onto a ramp and disconnect the battery.
- 2 Drain the cooling system. 26.10.01.
- 3 Remove the air duct. 80.15.31.
- 4 Remove the air cleaner.
- 5 Remove the inlet manifold complete with carburetters. 19.15.15.
- 6 Remove the camshaft cover.
- 7 Remove the distributor cap.
- 8 Remove the semi-circular grommet.
- 9 Turn the engine over so that the camshaft sprocket bottom bolt is accessible.
- 10 Unlock and remove the bottom bolt.
- 11 Anchor the camshaft sprocket to the support bracket.
- 12 Turn the engine over so that the timing mark on the camshaft flange is in line with groove in the camshaft front bearing cap and the distributor rotor arm points to the manifold rear attachment hole in the cylinder head.
- 13 Unlock and remove the camshaft sprocket top retaining bolt.

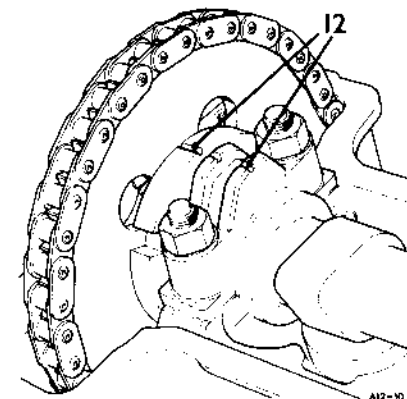
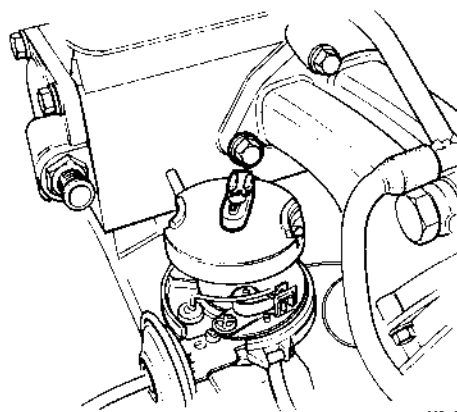
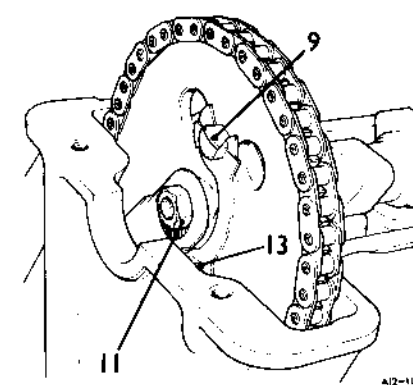

- 14 Disconnect the pipe from the water transfer housing.
- 15 Raise the ramp and disconnect the exhaust front pipe from the manifold flange.
- 16 Lower the ramp and remove the two cylinder head bolts to timing cover nuts and bolts.
- 17 Slacken the cylinder head retaining nuts and bolts in the reverse order as shown in operation 12.29.27.
- 18 Remove the five cylinder head studs and five bolts.
- 19 Withdraw the cylinder head complete with exhaust manifold.
- 20 Remove the cylinder head gasket.

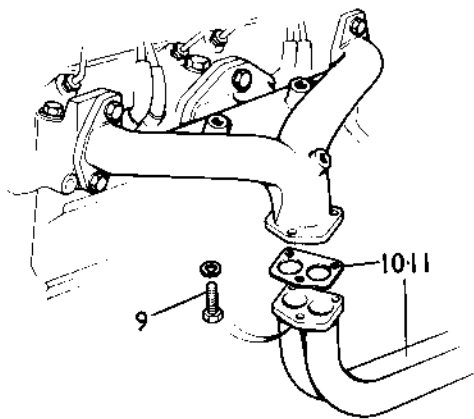

#### Refitting

- 21 Clean the cylinder block and cylinder head mating faces.
- 22 Insert two guide studs in the cylinder block bolt holes as illustrated, to facilitate fitting the cylinder head and gasket.

**NOTE:** Suitable guide studs may be made to the dimensioned drawing and to enable the studs to be inserted and withdrawn a slot to accommodate a screwdriver blade should be made in one end.

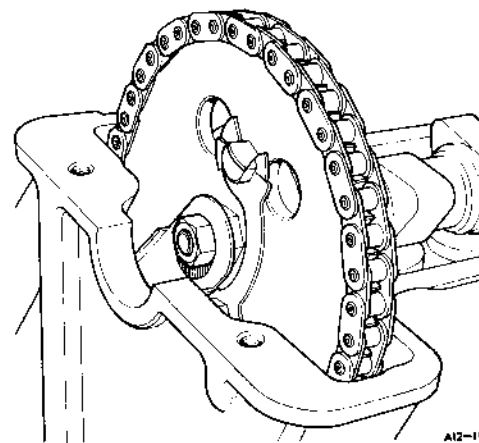
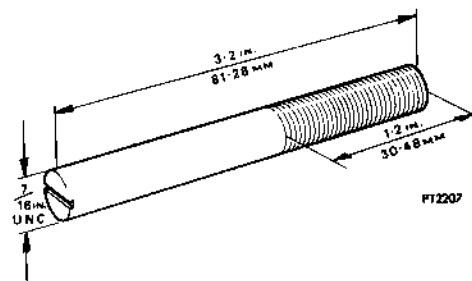
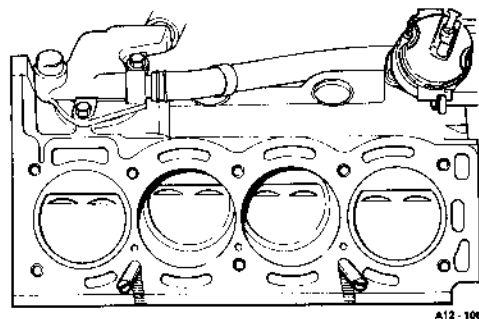
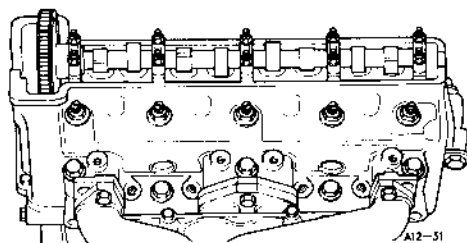
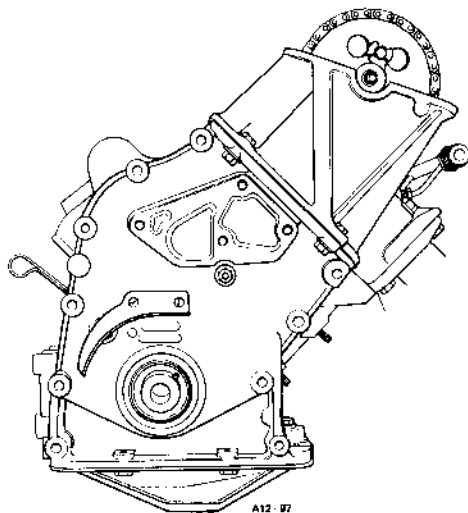

- 23 Check that number 1 and 4 pistons are at T.D.C. and that the distributor rotor arm is in the same position as in instruction 12.
- 24 Fit the cylinder head gasket.
- 25 Fit the cylinder head locating it over the two guide studs.
- 26 Fit the five cylinder head studs.
- 27 Remove the two guide studs.
- 28 Fit and finger tighten only the five cylinder head bolts and washers.
- 29 Fit and finger tighten the five cylinder head nuts, washers and the two brackets for locating the spark plug leads.
- 30 Tighten the nuts and bolts to the correct torque — see 'TORQUE WRENCH SETTINGS' — in the sequence shown in operation 12.29.27.
- 31 Fit the lock washer and camshaft sprocket top retaining bolt.
- 32 Turn the engine over to enable the bottom bolt to be fitted.
- 33 Tighten and lock the two bolts.
- 34 Remove the 'slave' nut from the camshaft sprocket.
- 35 Fit the semi-circular grommet to the cylinder head.
- 36 Fit the two timing covers to the cylinder head nuts and bolts.
- 37 Fit the camshaft cover.
- 38 Connect the heater hose to the water transfer housing.
- 39 Fit the plug leads and the distributor cap.
- 40 Raise the ramp and connect the exhaust down-pipe to the manifold flange.
- 41 Lower the ramp and fit the inlet manifold complete with carburettors. 30.15.02.
- 42 Fit the air cleaner. 19.10.02
- 43 Fit the air duct. 80.15.31.
- 44 Fill the cooling system. 26.10.01.
- 45 Connect the battery and drive the car off the ramp.

# CYLINDER HEAD GASKET – USA Specification

Remove and refit

12.29.02

## Removing

- 1 Drive the car onto a ramp and disconnect the battery.
- 2 Drain the cooling system. 26.10.01.
- 3 Remove the air duct. 80.15.31.
- 4 Remove the air cleaner.
- 5 Remove the inlet manifold complete with carburetters. 19.15.15.
- 6 Remove the camshaft cover.
- 7 Remove the distributor cap.
- 8 Remove the semi-circular grommet.
- 9 Turn the engine over so that the camshaft sprocket bottom bolt is accessible.
- 10 Unlock and remove the bottom bolt.
- 11 Anchor the camshaft sprocket to the support bracket.
- 12 Turn the engine over so that the timing mark on the camshaft flange is in line with groove in the camshaft front bearing cap and the distributor rotor arm points to the manifold rear attachment hole in the cylinder head.
- 13 Unlock and remove the camshaft sprocket top retaining bolt.

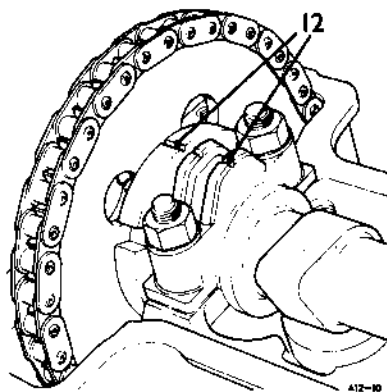
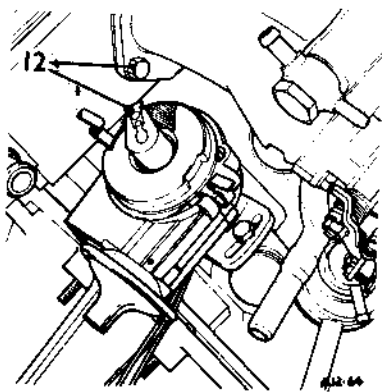
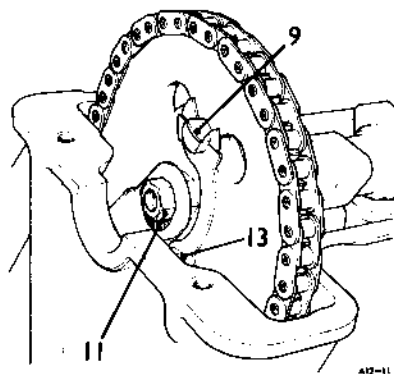

- 14 Disconnect the pipe to the check valve.
- 15 Disconnect the pipe from the water transfer housing.
- 16 Raise the ramp and disconnect the exhaust front pipe from the manifold flange.
- 17 Lower the ramp and remove the two cylinder head bolts to timing cover nuts and bolts.
- 18 Slacken the cylinder head retaining nuts and bolts in the reverse order as shown in operation 12.29.27.
- 19 Remove the five cylinder head studs and five bolts.
- 20 Withdraw the cylinder head complete with exhaust manifold.
- 21 Remove the cylinder head gasket.

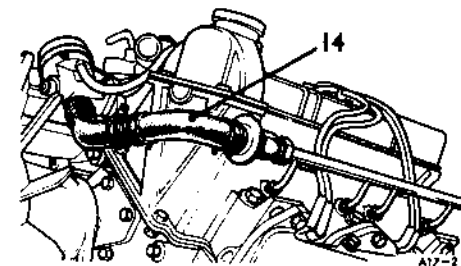

## Refitting

- 22 Clean the cylinder block and cylinder head mating faces.
- 23 Insert two guide studs in the cylinder block bolt holes as illustrated, to facilitate fitting the cylinder head and gasket.  
**NOTE:** Suitable guide studs may be made to the dimensioned drawing and to enable the studs to be inserted and withdrawn a slot to accommodate a screwdriver blade should be made in one end.
- 24 Check that number 1 and 4 pistons are at T.D.C. and that the distributor rotor arm is in the same position as in instruction 12.
- 25 Fit the cylinder head gasket.
- 26 Fit the cylinder head locating it over the two guide studs.
- 27 Fit the five cylinder head studs.
- 28 Remove the two guide studs.
- 29 Fit and finger tighten only the five cylinder head bolts and washers.
- 30 Fit and finger tighten the five cylinder head nuts, washers and the two brackets for locating the spark plug leads.
- 31 Tighten the nuts and bolts to the correct torque – see 'TORQUE WRENCH SETTINGS' – in the sequence shown in operation 12.29.27.

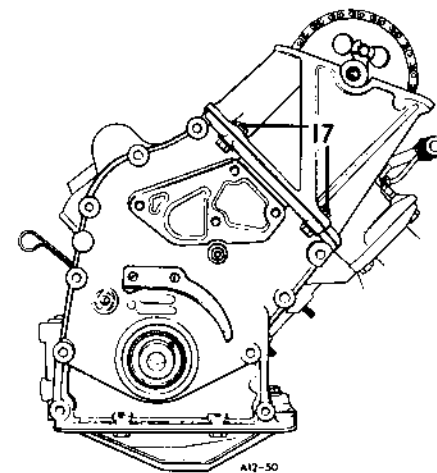
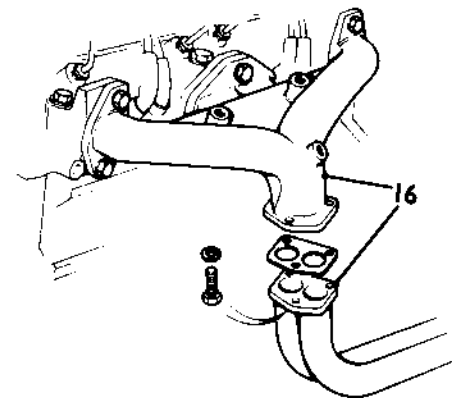

- 32 Fit the lock washer and camshaft sprocket top retaining bolt.
- 33 Turn the engine over to enable the bottom bolt to be fitted.
- 34 Tighten and lock the two bolts.
- 35 Remove the 'slave' nut from the camshaft sprocket.
- 36 Fit the semi-circular grommet to the cylinder head.
- 37 Fit the two timing covers to cylinder head nuts and bolts.
- 38 Fit the camshaft cover.
- 39 Connect the heater hose to the water transfer housing.
- 40 Connect the hose to the check valve.
- 41 Fit the plug leads and the distributor cap.
- 42 Raise the ramp and connect the exhaust down-pipe to the manifold flange.
- 43 Lower the ramp and fit the inlet manifold complete with carburetters. 30.15.02.
- 44 Fit the air cleaner. 19.10.02.
- 45 Fit the air duct. 80.15.31.
- 46 Fill the cooling system. 26.10.01.
- 47 Connect the battery and drive the car off the ramp.

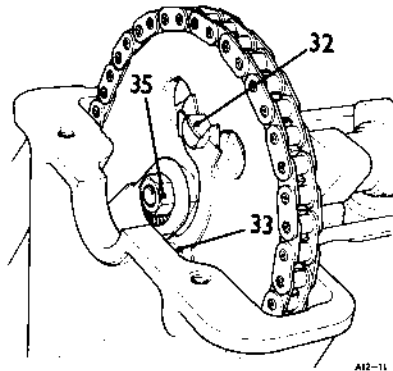
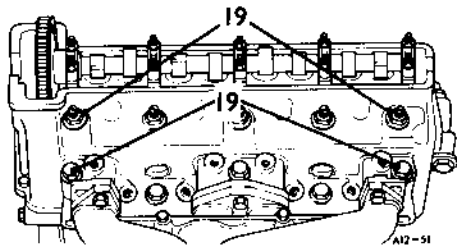
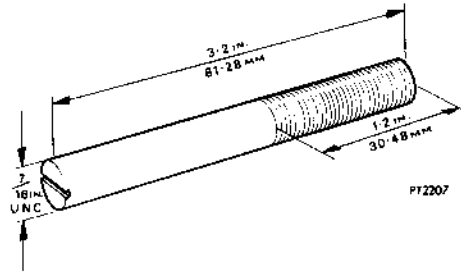
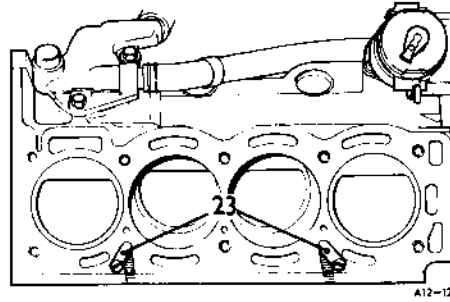

**WATER TRANSFER HOUSING**

Remove and refit 12.29.04

**Removing**

- 1 Disconnect the battery.
- 2 Drain the cooling system. 26.10.01.
- 3 Remove the fresh air duct. 80.15.31.
- 4 Disconnect the heater hose from the housing.
- 5 Remove the five bolts and plain washers securing the housing to the cylinder head.

**Refitting**

- 6 Clean the cylinder head and housing mating faces.
- 7 Using a new gasket fit the housing and secure with the five bolts and plain washers.
- 8 Connect the heater hose to the housing.
- 9 Fit the fresh air duct.
- 10 Fill the cooling system. 26.10.01.
- 11 Reconnect the battery.

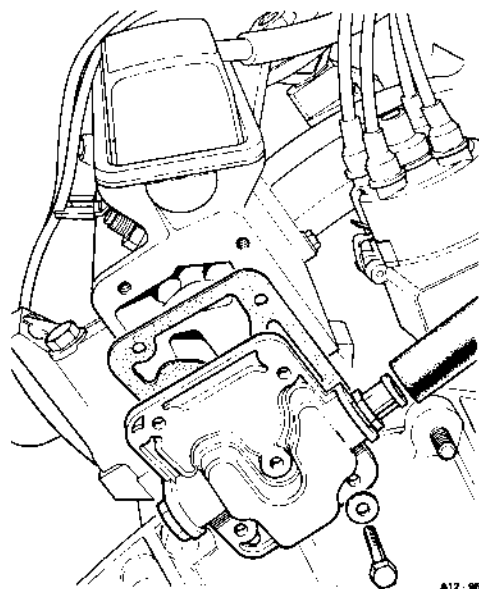

A12-96

**CYLINDER HEAD**

Remove and refit 12.29.10

This operation is covered under CYLINDER HEAD GASKET 12.29.02.

**CYLINDER HEAD**

Overhaul 12.29.18

Which includes:

- Valves – exhaust – remove and refit 12.29.60
- Valves – inlet and exhaust – remove and refit 12.29.62
- Valves – inlet – remove and refit 12.29.63
- Valve guide – inlet – remove and refit 12.29.70
- Valve guide – exhaust – remove and refit 12.29.71
- Inlet valve seat – remove and refit 12.29.76
- Exhaust valve seat – remove and refit 12.29.77

Special tools: S352, S60A-8 with 60A and 560A-2

**Dismantling**

- 1 Remove the cylinder head. 12.29.10.
  - 2 Remove the exhaust manifold.
  - 3 Remove the camshaft. 12.13.01 instructions 8 to 10.
  - 4 Remove the tappets and pallets keeping them in their correct order.
  - 5 Compress each valve spring in turn using special tool S352 and extract the collets, collars, springs, spring seats and valves.
- NOTE:** Keep all components in sets for reassembly in their original positions unless new items are to be fitted.
- 6 Remove all carbon deposits from the combustion chambers, exhaust ports and cylinder head face.

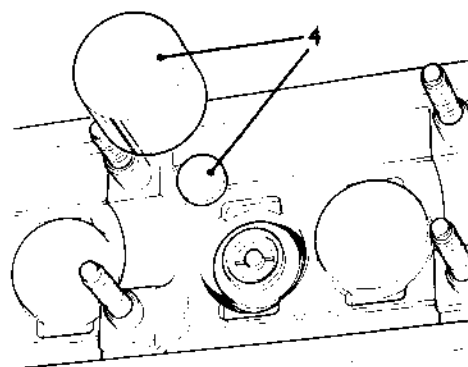

A12-22

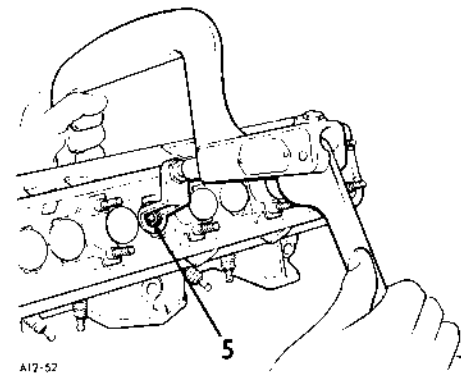

A17-52

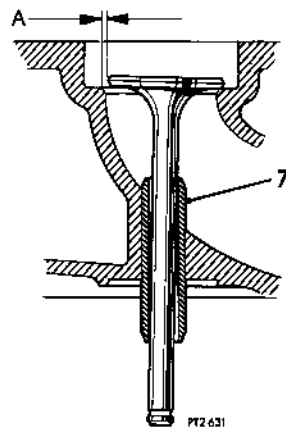

PT2-631

**Valve guides – checking**

- 7 Check the inlet and exhaust valve guides for wear by inserting a new valves in each guide and tilting it. If movement across the valve seat – dimension 'A', 0.20 in (5.08 mm) – is exceeded, the valve guide should be renewed.

**Valve guides – removing inlet and exhaust**

- 8 Position main tool S60A on the top face of the cylinder head and using adaptor S60A-2 withdraw any worn guides.

**Valve guides – fitting inlet and exhaust**

- 9 Apply graphite grease to the new valve guides. Assemble main tool S60A and adaptors S60A-2 and S60A-8 on the combustion face of the cylinder head and draw-in the new guides.

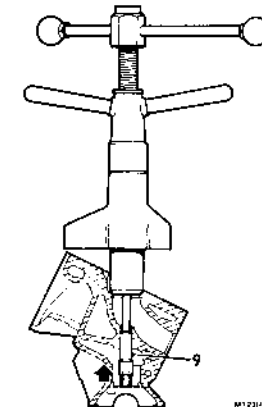

M1231F

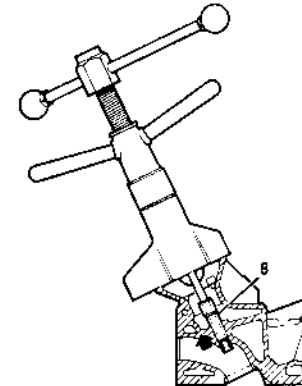

M1232

### Valve guides – reaming inlet and exhaust

- 10 Ream out the newly fitted guides using a 0.3125 in (7,95 mm) reamer.
- 11 Re-cut the valve seats and grind-in the valves where new guides have been fitted.

### Valves

- 12 Examine the valves and discard any with worn or bent stems and badly pitted or burnt heads. Valves with the head thickness reduced below dimension 'A' should be renewed. Valves in an otherwise satisfactory condition may be refaced.

### Valve springs

- 13 Examine the valve springs for cracks and distortion. Check the springs against the information in data and discard any that do not meet these requirements.

### Valve seat inserts

- 14 Examine the valve seat inserts for wear pits, scores and pooketing. Reface where necessary, removing only the minimum of material to obtain a gas tight seal and a correctly seating valve.
  - A Correctly seating valve.
  - B Incorrectly seating valve.

- 15 Valve seat inserts that cannot be restored by machining to provide a correctly seating valve must be renewed as follows:

Machine-out the existing inserts taking care not to damage the insert bores in the cylinder head.

- 16 Machine the INLET valve seat bore in the cylinder head – dimension C to 1.665 to 1.666 in (42.29 to 42.32 mm).

- 17 Machine the EXHAUST valve seat bore – dimension B to 1.329 to 1.330 in (33.75 to 33.78 mm).

- 18 Heat the cylinder head uniformly to a temperature of 180°C and immediately fit the new inlet and exhaust valve seats squarely into the cylinder head.

- 19 Allow the cylinder head to cool and machine the inlet and exhaust seats to an inclusive angle of 89° – dimension D.

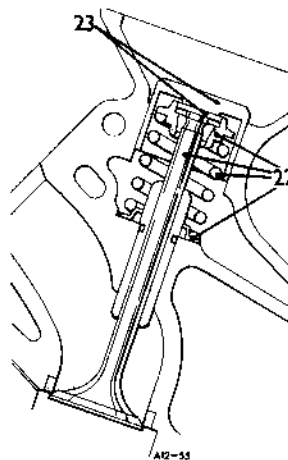
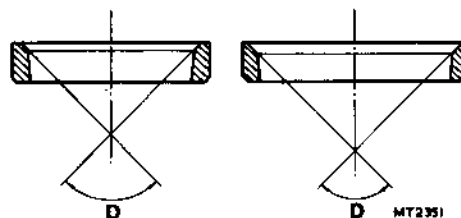
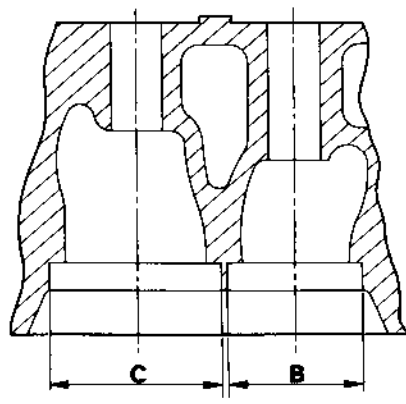
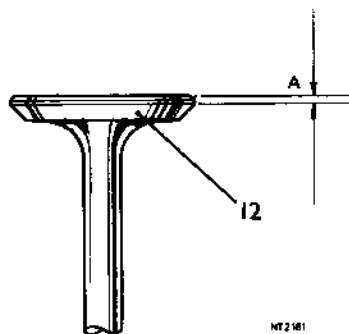
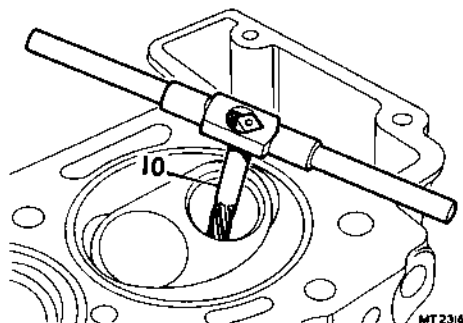

### Lapping-in the valves

- 20 Insert each valve, in turn in its guide and lap-in using coarse followed by fine carborundum compound, until a continuous narrow band is obtained round the valve face and its seating.
- 21 Clean off all traces of compound from the valves and inserts.

### Reassembling

- 22 Using the valve spring compressor S352, fit the valves, spring seats, spring collars, and secure with the split collets.
- 23 Fit the pallets and tappets.
- 24 Fit the camshaft and bearing caps ensuring that they are fitted in their correct positions and tighten the nuts to the correct torque – see 'TORQUE WRENCH SETTINGS'.
- 25 Check and if necessary adjust the valve clearances. 12.29.48.
- 26 Fit the exhaust manifold.
- 27 Fit the cylinder head. 12.29.10.

### DATA

#### Valves

##### Inlet

Overall length . . . . .	4.259 to 4.269 in (108,17 to 108,43 mm)
Head diameter . . . . .	1.560 in (39,62 mm)
Angle of face . . . . .	45°
Stem diameter . . . . .	0.3107 to 0.3113 in (7,881 to 7,907 mm)
Stem to guide clearance. . . . .	0.0017 to 0.0023 in (0,043 to 0,058 mm)

##### Exhaust

Overall length . . . . .	4.264 to 4.543 in (108,30 to 115,4 mm)
Head diameter . . . . .	1.280 in (32,51 mm)
Angle of face . . . . .	45°
Stem diameter . . . . .	0.3100 to 0.3106 in (7,87 to 7,89 mm)
Stem to guide clearance. . . . .	0.0014 to 0.0030 in (0,035 to 0,076 mm)

#### Valve springs

Free length . . . . .	1.600 in (40,40 mm)
Fitted length . . . . .	1.440 in (36,57 mm)
Number of working coils . . . . .	3¾

#### Valve seat inserts

Outside diameter – Inlet . . . . .	1.6695 to 1.6705 in (42,405 to 42,430 mm)
– Exhaust . . . . .	1.3335 to 1.3345 in (33,870 to 33,896 mm)
Angle of seat . . . . .	42½°

## CYLINDER HEAD NUTS AND BOLTS

Tighten 12.29.27

- To avoid distortion of the cylinder head it is important that the retaining nuts and bolts are tightened in the following alphabetical order, as illustrated, to the correct torque – see 'TORQUE WRENCH SETTINGS'.  
A. B. C. D. E. F. G. H. I. J.
- When releasing the nuts and bolts, prior to removing the cylinder head, the above sequence must be reversed i.e.  
J. I. H. G. F. E. D. C. B. A.
- When checking the torque loading of the nuts and bolts they should first be slackened off to overcome static friction and then re-tightened to the correct torque figure.

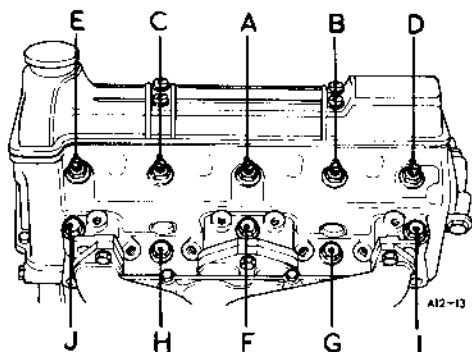

## CAMSHAFT COVER

Remove and refit 12.29.42

### Removing

- Disconnect the H.T. leads from the spark plugs.
- Disconnect the H.T. leads from the retainers on the camshaft cover and move the leads away.
- Pull off the breather hose from the camshaft cover.
- Remove the four slotted sleeve nuts and sealing washers.
- Remove the two screws and washers.
- Remove the camshaft cover.
- Remove the gasket.

### Refitting

- Clean the camshaft cover and cylinder head mating faces.
- Lightly smear both sides of a new gasket with grease.
- Fit the gasket and camshaft cover, locating over the four studs.
- Fit the four slotted sleeve nuts using, if necessary new:
  - Washers
  - Sealing rings.
- Fit the two screws and spring washers.
- Fit the breather hose.
- Connect the H.T. leads to the spark plugs and attach the lead clips to the retainers.

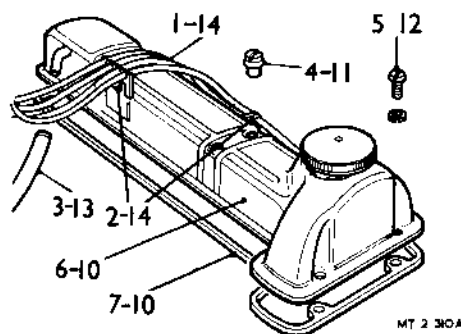

MT 2 30A

## VALVE CLEARANCE

Check and adjust 12.29.48

**NOTE:** This operation may be carried out with the cylinder head on the engine or on the bench. When on the bench turn the camshaft using a spanner on the hexagon at the rear of the shaft.

### Checking

- Disconnect the battery.
- Remove the camshaft cover. 12.29.42.
- Slacken off the camshaft bearing cap nuts and re-tighten to the correct torque – see 'TORQUE WRENCH SETTINGS'.
- Rotate the engine and check and record the maximum clearance of each valve, in turn, using a feeler gauge between the cam heel and tappet. The maximum clearance exists when the cam is vertical to the cylinder head.

**NOTE:** If all the valve clearances are correct to that given in DATA, refit the camshaft cover and reconnect the battery. Should adjustments be necessary continue with the following instructions.

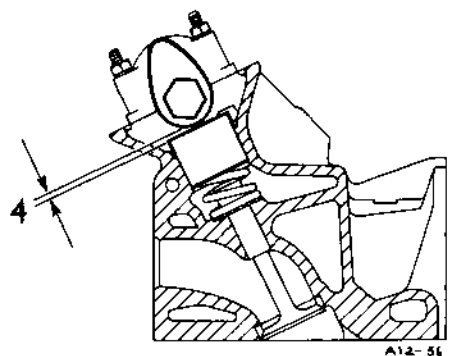
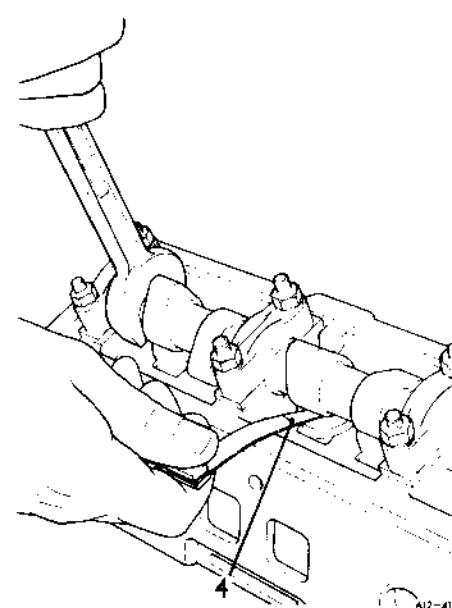

### Adjusting

- 5 Remove the camshaft. 12.13.01.
- 6 Withdraw each tappet and pallet where the clearance requires adjustment and keep them in their numbered sequence.
- 7 Using a micrometer, measure and record the thickness of each pallet.
- 8 The following calculations should be followed, as an example, to select a new pallet of the appropriate thickness to give a correct valve clearance.

#### Excessive clearance (exhaust valve used for example)

Valve clearance recorded	0.023 in
Valve clearance required	0.018 in

Valve clearance excess	+ 0.005 in
Plus pallet thickness recorded	0.090 in

= Pallet thickness required      0.095 in

#### Insufficient clearance (inlet valve used for example)

Valve clearance recorded	0.005 in
Valve clearance required	0.008 in

Insufficient clearance	- 0.003 in
Pallet thickness recorded	0.100 in

Pallet thickness required      0.097 in

- 9 Fit the new pallets where necessary and refit the tappets 12.29.57 instructions 5 to 7.
- 10 Refit the camshaft. 12.13.01.
- 11 Fit the camshaft cover. 12.29.42.

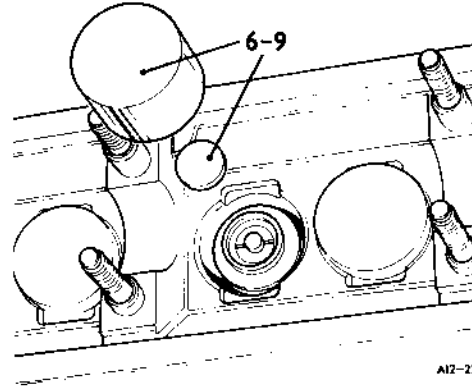

## TAPPETS

Remove and refit      12.29.57

### Removing

- 1 Disconnect the battery.
- 2 Remove the camshaft cover. 12.29.42.
- 3 Remove the camshaft. 12.13.01.
- 4 Lift out the tappets and pallets, and identify them for reassembly.

### Examination

- 5 Check the tappets for wear, scoring and pitting and discard as necessary.

### Refitting

- 6 Fit the pallets into the valve collars.
- 7 Fit the tappets to the same valve assemblies renewing any faulty ones.
- 8 Refit the camshaft 12.13.01 ensuring that the valve clearances are checked and if necessary adjusted.
- 9 Fit the camshaft cover. 12.29.42.
- 10 Reconnect the battery.

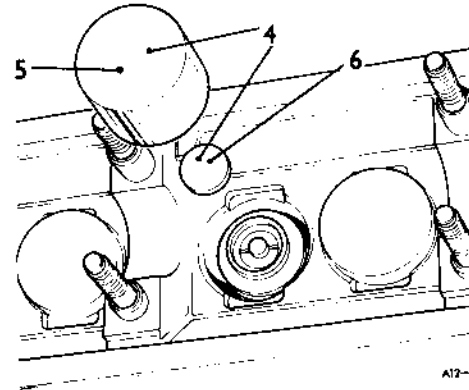

## DATA

### Valve clearances

Inlet	0.008 in (0.2 mm)
Exhaust	0.018 in (0.5 mm)



**ENGINE AND GEARBOX ASSEMBLY—  
UK and Europe Specification**

**Remove and refit 12.37.01**

**Removing**

- 1 Disconnect the battery.
- 2 Remove the bonnet. 76.16.01.
- 3 Remove the fresh air duct.
- 4 Remove the radiator. 26.40.01.
- 5 Disconnect, from the engine, the heater hoses.
- 6 Disconnect the overflow hose from thermostat housing.
- 7 Pull off the air intake hoses from the air cleaner.
- 8 Disconnect the brake servo hose from the engine.
- 9 Disconnect the oil pressure lead from the switch.
- 10 Disconnect the H.T. and L.T. leads from the distributor.
- 11 Disconnect the water temperature transmitter lead from the thermostat housing switch.
- 12 Disconnect the harness plug from the alternator.
- 13 Remove the fuel pipe from the pump inlet, and blank-off the pipe and pump.
- 14 Disconnect the throttle cable.
- 15 Disconnect the mixture control cable.
- 16 Pull-off the float chamber spill pipe from the rear carburetter.
- 17 Remove the bonnet lock. 76.16.21.
- 18 Remove the exhaust front pipe. 30.10.09.
- 19 Remove the gear lever. 37.16.04.
- 20 Jack up the front of the car and lower onto axle stands.
- 21 Jack up the rear of the car and lower onto axle stands.
- 22 Mark the relationship of the propshaft to the gearbox drive flange and disconnect it from the gearbox.
- 23 Disconnect the two reverse light snap connectors.
- 24 Remove the speedometer cable from the gearbox.
- 25 Remove the clutch slave cylinder and move to one side.
- 26 Remove the engine LH mounting retaining nut.

- 27 Remove the stabiliser — where fitted. 12.45.16.
- 28 Remove starter motor shield.
- 29 Remove the battery lead from the starter motor solenoid.
- 30 Disconnect the Lucar connector from the starter motor solenoid.
- 31 Remove the bolt securing the battery earth lead to the bell housing.
- 32 Remove the propshaft guard.
- 33 Lower the propshaft.
- 34 Fit slings to engine lifting hooks and hoist to take the weight of the engine.
- 35 Support the gearbox with a trolley jack.
- 36 Remove the four nuts retaining the rear mounting to the body.
- 37 Remove the RH engine mounting nut.
- 38 Lower the jack supporting the gearbox.
- 39 Hoist the engine and gearbox assembly and manoeuvre from the engine bay.

**Refitting**

- 40 Fit slings to the engine lifting eyes, hoist engine and gearbox assembly and manoeuvre into the engine bay.
- 41 Place a trolley jack under the gearbox.
- 42 Lower the engine to line-up the LH mounting with its sub-frame location.
- 43 Continue lowering, so that the engine RH rubber mounting stud locates in the slot in the body bracket.
- 44 Raise the gearbox and connect up the cross member to the body locating studs.
- 45 Fit the nut and washer to the RH engine mounting stud.
- 46 Fit the nut and washer to the engine LH mounting stud.
- 47 Remove slings from engine lifting eyes.
- 48 Remove the jack from beneath gearbox.
- 49 Secure the propshaft to the gearbox lining up the identification marks. Tighten the nuts to the correct torque — see 'TORQUE WRENCH SETTINGS'.
- 50 Fit the stabiliser — where fitted. 12.45.16.
- 51 Fit the propshaft guard.
- 52 Secure RH harness to its retaining clip.
- 53 Connect the reverse light snap connectors.

- 54 Fit the clutch slave cylinder.
- 55 Secure the LH harness to its retaining clip.
- 56 Connect the negative earth lead from the battery to the bell housing.
- 57 Fit battery lead to starter motor solenoid.
- 58 Fit Lucar connector to the starter motor solenoid.
- 59 Fit the starter motor shield.
- 60 Fit the speedometer cable to the gearbox.
- 61 Fit the exhaust front pipe. 30.10.09.
- 62 Jack up rear of car and remove axle stands
- 63 Jack up front of car and remove axle stands.
- 64 Fit and align the bonnet lock. 76.16.21.
- 65 Fit spill pipe to the rear carburetter.
- 66 Fit the heater hoses to the engine connections.
- 67 Remove the blanking and fit the fuel pipe to the pump.
- 68 Fit the oil pressure warning light Lucar to the switch.
- 69 Connect the L.T. and H.T. leads to the distributor.
- 70 Connect the harness plug to the alternator.
- 71 Connect the coolant temperature transmitter lead.
- 72 Fit the vacuum hose to the engine.
- 73 Fit and adjust the throttle cable
- 74 Fit the mixture control cable.
- 75 Fit the air intake hoses to the air cleaner.
- 76 Connect the overflow hose to the thermostat housing.
- 77 Fit the radiator. 26.40.01.
- 78 Fit the fresh air duct.
- 79 Fit the bonnet. 76.16.01
- 80 Fit the gear lever. 37.16.04.
- 81 Check the coolant level.
- 82 Check and if necessary top up the sump with oil of a recommended make and grade.
- 83 Check and if necessary top up the gearbox oil level — see 'MAINTENANCE'.
- 84 Connect the battery.
- 85 Start the engine and run until normal operating temperature is reached whilst checking for coolant and oil leaks.

- 86 Check and adjust the ignition timing. 86.35.15.
- 87 Check and if necessary tune and adjust the carburetters. 19.15.02.
- 88 Road test the car.

**ENGINE AND GEARBOX ASSEMBLY —  
USA and Canada Specification**

**Remove and refit 12.37.01**

**Removing**

- 1 Disconnect the battery.
- 2 Disconnect the bottom hose at the radiator and allow the collant to drain.
- 3 Remove the bonnet. 76.16.01.
- 4 Remove the radiator. 26.40.01.
- 5 Remove the fresh air duct. 80.15.31.
- 6 Remove the hot air hose.
- 7 Disconnect the heater hoses at the bulkhead connections.
- 8 Disconnect the brake servo hoses at the inlet manifold connection.
- 9 Disconnect two hoses from the adsorption canister.
- 10 Disconnect the cooling system expansion hose from the thermostat housing.
- 11 Disconnect the vacuum hose from the inlet manifold to the anti-run-on valve.
- 12 Disconnect the electrical leads from the following:
  - a The oil pressure switch.
  - b Alternator.
  - c Temperature transmitter.
  - d Anti-run-on valve.
  - e L.T. leads from ignition coil.
  - f Lead from alternator to the throttle jack.
  - g H.T. lead from the coil to the distributor.
- 13 Disconnect the main fuel feed from the pump to the carburetter fuel line.
- 14 Disconnect the choke cable from the rear carburetter.
- 15 Disconnect the throttle cable from the throttle linkage.
- 16 Remove the gear lever assembly. 37.16.04.
- 17 Jack-up the front and rear of the car and lower onto chassis stands.

*continued*

- 18 Disconnect the propeller shaft from the gearbox.
- 19 Disconnect the reverse light and seat belt interlock wires from the multi-way connector.
- 20 Remove the exhaust down-pipe. 30.10.09.
- 21 Disconnect the speedometer cable from the gearbox.
- 22 Remove the clutch slave cylinder. 33.35.01.
- 23 Remove the engine stabilizer complete (where fitted). 12.45.16.
- 24 Remove the nut securing the L.H. engine mounting rubber to the sub-frame.

- 25 Disconnect the starter motor leads.
- 26 Release the harness from the bell housing clips.
- 27 Remove bell housing bolts necessary to remove the clips and release the clutch hydraulic pipe.
- 28 Disconnect the main positive earth lead.
- 29 Remove the bonnet lock from the bulkhead. 76.16.21.
- 30 De-pressurize the air conditioning system - where fitted - and disconnect the hoses from the compressor. 82.30.05.
- 31 Using a sling with a 23 in leg to the rear lifting eye and an 18 in leg to the

- front eye or similar ratio raise the hoise to take the weight of the engine.
32. Disconnect the R.H. engine mounting rubber from the engine bracket.
33. Remove the five bolts and release the engine rear mounting cross-member from the body, complete with the tie bar and restraint cable - nut A.
- 34 Raise the rear end of the car.
- 35 Hoist the engine and remove the L.H. engine mounting.
- 36 Continue hoisting the engine and manoeuvre it from the car.
- 37 Lower the rear end of the car.

#### Refitting

- 38 Using a sling as in instruction 31 hoist the engine and gearbox assembly to a position over the engine bay.
- 39 Fit the L.H. engine mounting rubber to the sump cross-member.
- 40 Raise the rear end of the car and lower the engine unit into the car.
- 41 When the rear engine mounting is approximately 8 in from the floor lower the rear end of the car and jack-up the gearbox.

*continued*

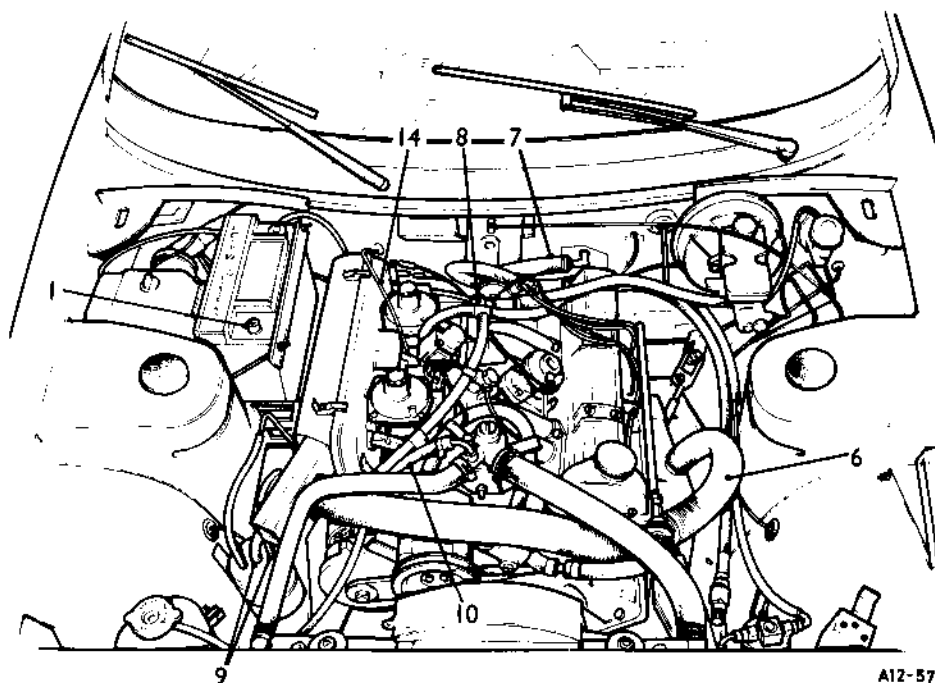

A12-57

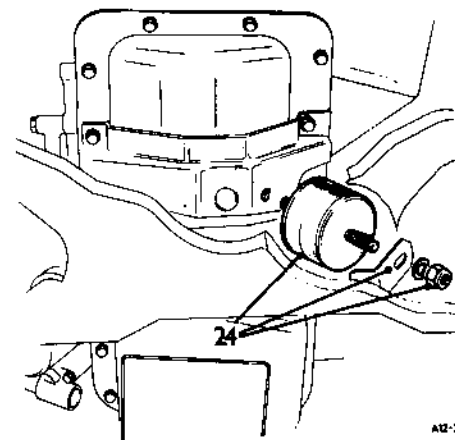

A12-31

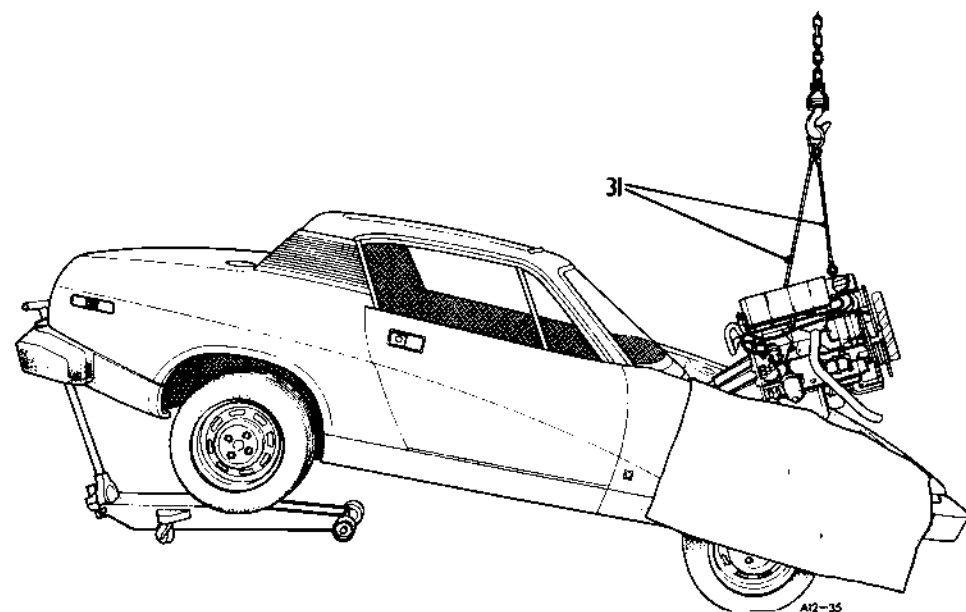

A12-35

- 42 Continue lowering the engine whilst guiding the L.H. engine mounting stud into its sub-frame location.
- 43 Remove the slings from the engine.
- 44 Connect up the R.H. engine mounting to the engine bracket.
- 45 Bolt the engine and gearbox assembly rear mounting to the body with the four bolts.
- 46 Connect the propeller shaft to the gearbox.
- 47 Fit the clutch slave cylinder.
- 48 Fit the bell housing bolts and secure the clutch hydraulic pipe over the bell housing with the clips, with an earth wire.
- 49 Fit the L.H. engine mounting retaining nut.
- 50 Connect the gearbox harness to the multi-way connector.
- 51 Connect up the main earth lead to the bell housing.
- 52 Fit the engine stabilizer and adjust to the correct setting – where fitted. 12.45.16.
- 53 Fit the starter motor heat shield.
- 54 Fit the exhaust down-pipe. 30.10.09.

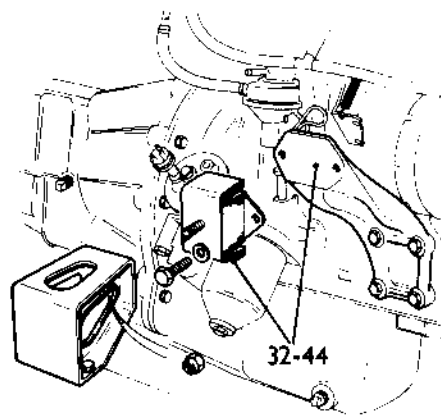
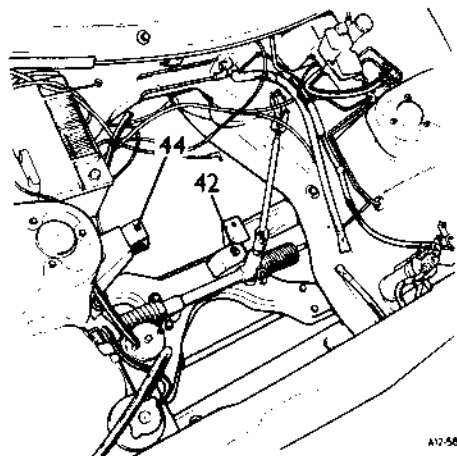

A12-30

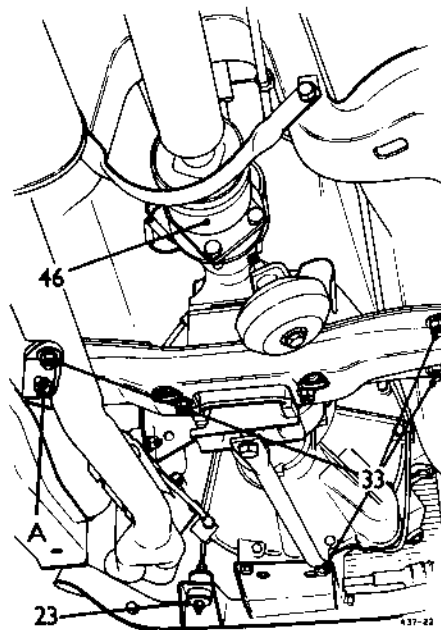

A17-23

- 55 If fitted connect the air conditioning hoses to the compressor.
- 56 Connect up the compressor electromagnet clutch lead.
- 57 Fit the heater pipes to the bulkhead connections. 80.25.07.
- 58 Fit the brake servo hose to the manifold.
- 59 Fit the mixture control cable.
- 60 Fit the throttle cable to the carburetter linkage.
- 61 Fit the anti-run-on vacuum pipe to the manifold.
- 62 Fit the main-line fuel pipe to the inlet side of the pump.
- 63 Connect up the electrical leads – reversing instruction 12.
- 64 Fit the cooling system expansion pipe to the thermostat housing.

- 65 Fit the pipes to the adsorption canister.
- 66 Connect the H.T. lead to the distributor.
- 67 Remove the blanking plug and fit the fuel pipe to the pump.
- 68 Fit the fresh air duct. 80.15.31.
- 69 Fit the radiator and connect the top and bottom hoses. 26.40.01.
- 70 Fit the hot air hose.
- 71 Fit the bonnet. 76.16.01.
- 72 Fit the gear lever assembly. 37.16.04.
- 73 Fill the cooling system. 26.10.01.
- 74 Fill the sump with oil of the correct grade to the high mark on the dipstick.
- 75 Check the gearbox oil level.
- 76 Connect the battery.

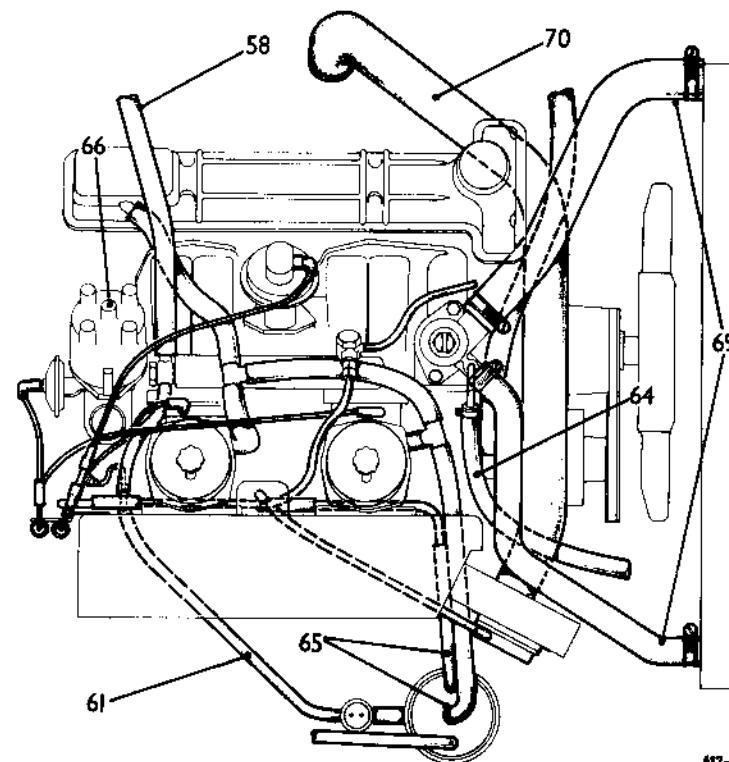

A17-11

## ENGINE ASSEMBLY — UK & Europe Specification

Strip and rebuild

12.41.05

Special tool: 38 U3

### Stripping

- 1 Remove the engine and gearbox assembly from the car 12.37.01 and drain the sump.
- 2 Remove the gearbox — noting the position of the remaining bolts for refitting.
- 3 Drain the cylinder block.
- 4 Remove the starter motor.
- 5 Remove the clutch.
- 6 Remove the inlet manifold complete with carburetters, air cleaner and dipstick and tube.

- 7 Remove the water pump and remove the bottom hose
- 8 Remove the fuel pump.
- 9 Remove the distributor.
- 10 Remove the R.H. engine mounting bracket.
- 11 Remove the alternator complete with bracket.
- 12 Remove the alternator link.
- 13 Remove the exhaust manifold.
- 14 Remove the fan pulley and viscous coupling.
- 15 Remove the water pump.
- 16 Remove the spark plugs.
- 17 Remove the flywheel — 12.53.07 instructions 4 to 6.
- 18 Remove the oil pressure switch.
- 19 Remove the crankshaft pulley.

- 20 Remove the front lifting eye.
- 21 Remove the oil filter bowl and sealing ring.
- 22 Remove the oil pump and hexagon drive.
- 23 Remove the oil transfer housing.
- 24 Withdraw the six bolts and remove the rear adaptor plate.
- 25 Remove the camshaft cover.
- 26 Unlock and remove one of the camshaft sprocket retaining bolts.
- 27 Anchor the sprocket with a 'slave' nut to the support bracket and unlock and remove the remaining bolt.
- 28 Remove the two nuts and bolts securing the timing cover to the cylinder head.
- 29 Slacken the cylinder head retaining nuts and bolts in the reverse order as shown in operation 12.29.27.

- 30 Remove the five cylinder head studs and five bolts.
- 31 Withdraw the cylinder head complete with the camshaft and discard the gasket.
- 32 Remove the sump.
- 33 Remove the oil pick-up strainer.
- 34 Withdraw the remaining bolts — noting their positions and remove the timing cover.
- 35 Remove the oil thrower.
- 36 Remove the two retaining bolts and withdraw the timing chain tensioner.
- 37 Remove the three bolts securing the two chain guides and support bracket.
- 38 Remove the guides and support bracket complete with the chain and camshaft sprocket.

*continued*

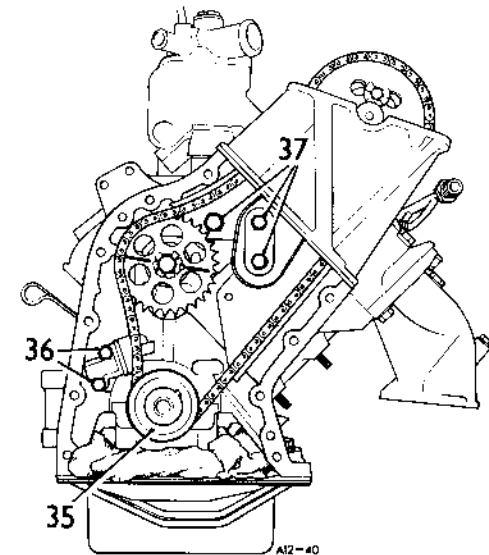
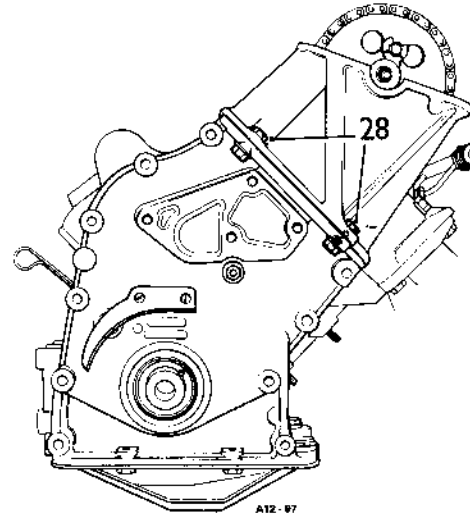
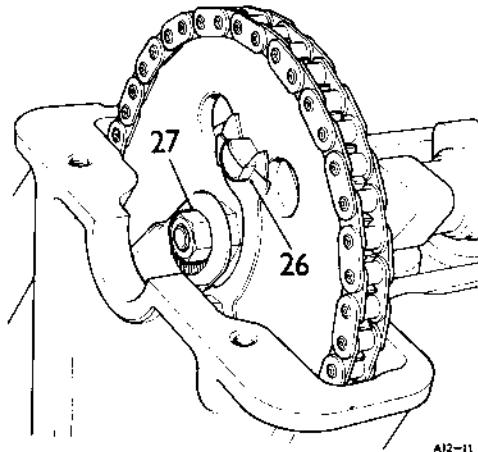
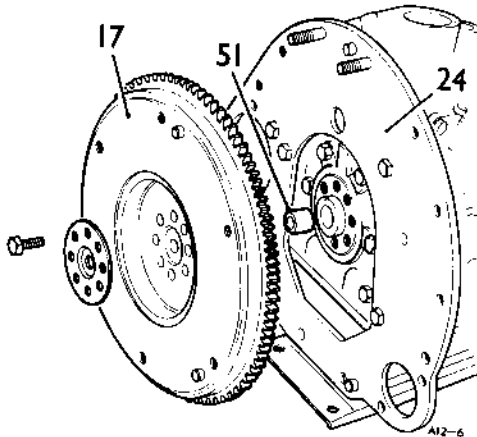

- 39 Turn the jackshaft sprocket to expose the two Allen screws retaining the jackshaft keeper plate. Remove the screws and withdraw the plate.
- 40 Withdraw the jackshaft and sprocket from the cylinder block.
- 41 Unlock the tab washer and remove the bolt and sprocket from the jackshaft.
- 42 Withdraw the crankshaft sprocket.
- 43 Remove the drive key and shims from the crankshaft.
- 44 Remove the six bolts and remove the rear main oil seal and housing.

- 45 Remove the nuts securing the connecting rod bearing caps and withdraw the caps and lower shells ensuring that if the shells are to be refitted they are kept identified with their respective caps.
- 46 Push the connecting rods upwards and withdraw the piston assemblies through the top of the bores, keeping the shells identified with their respective connecting-rods.
- 47 Remove the ten bolts securing the five main bearing caps and withdraw the caps and lower shells.

- 48 Lift out the crankshaft.
- 49 Remove the upper shells from the crankcase.
- 50 Remove the thrust washers from number three main bearing.
- 51 Withdraw the spigot bush from the crankshaft.

**NOTE:** The following rebuilding instructions assume that all the individual components and assemblies have been examined, worn parts renewed and assemblies overhauled. Moreover, all joint faces are clean and parts lubricated before assembly.

- 52 Fit the five main bearing upper shells ensuring that the keeper tags locate in the recess.
- 53 Fit the crankshaft thrust washers to number 3 main bearing noting that the oil grooves face outwards.
- 54 Lower the crankshaft into the crankcase.
- 55 Fit the lower shells to the main bearing caps and fit them to the crankcase. Partially tighten the securing bolts.

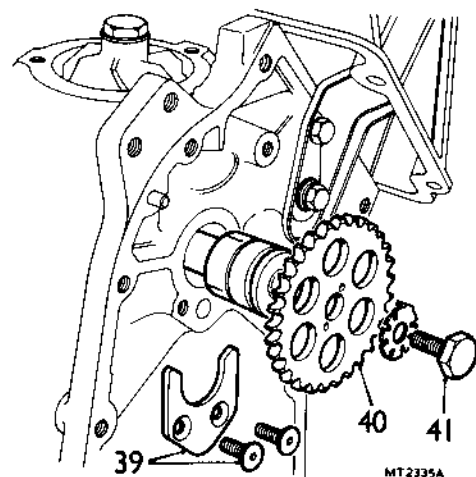

MT2335A

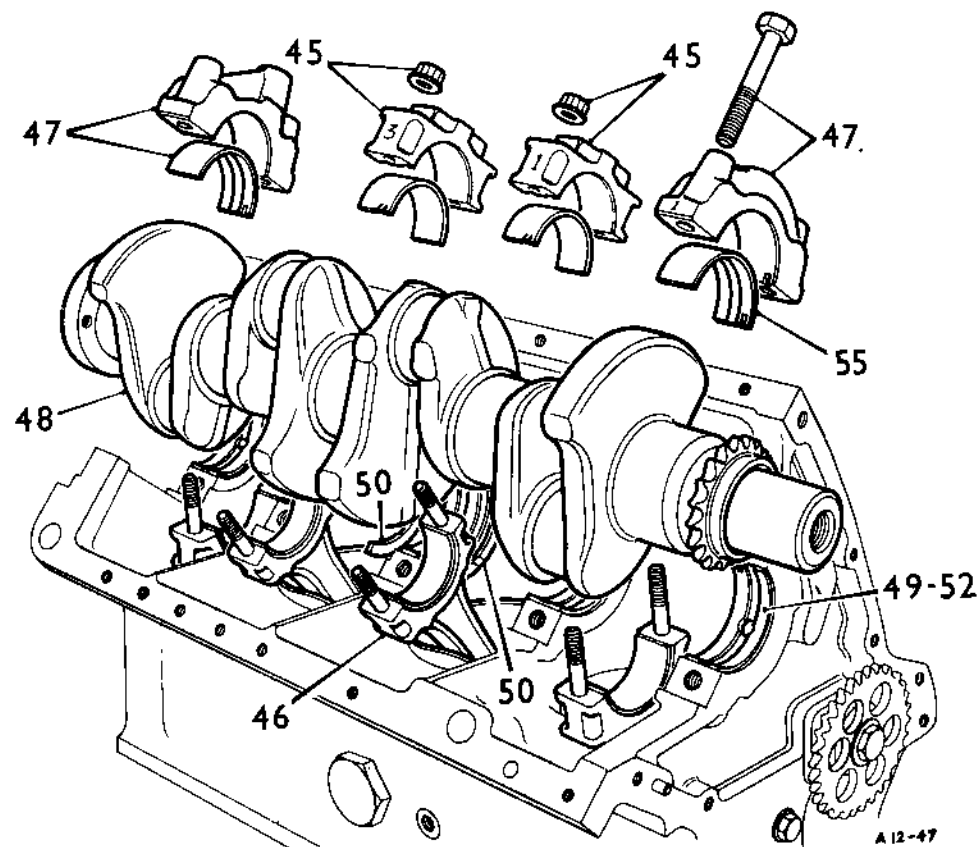

A 12-47

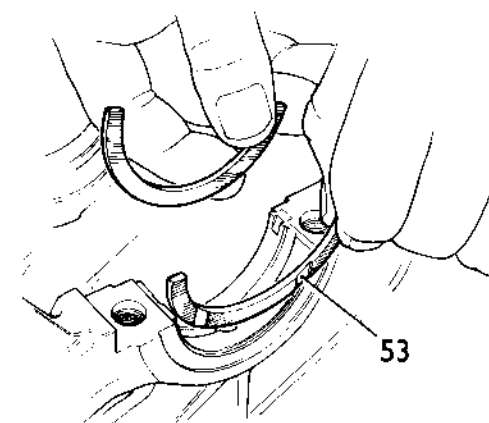

PT 139

- 56 Using either a dial gauge or feelers check the crankshaft end-float – see data.
- 57 Tighten the main bearing cap bolts to the correct torque – see 'TORQUE WRENCH SETTINGS'.
- 58 Stagger the piston ring gaps, avoiding a gap on the thrust side and compress the rings using special tool number 38 U3.
- 59 Turn the crankshaft to position numbers 2 and 3 crankpins at B.D.C. Insert the respective connecting rod and piston assemblies into the bores and tap the pistons home noting that the flat raised part and the valve head recesses on the piston crown are fitted to the L.H. side of the engine.
- 60 Fit the upper bearing shells to the connecting rods ensuring that the keeper tags locate in the recesses and pull the connecting rods onto the journals.
- 61 Fit the lower shells to the connecting rod caps ensuring that the keeper tags locate in the recesses and fit them to the connecting rods. Tighten new nuts to the correct torque – see 'TORQUE WRENCH SETTINGS'.
- 62 Repeat instructions 58 to 61 on numbers 1 and 2 pistons and connecting rod assemblies.

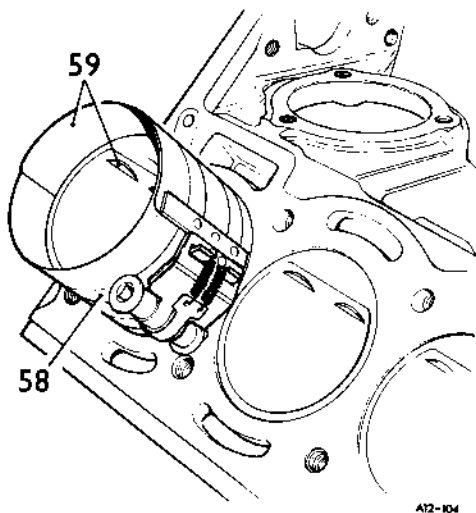

A12-104

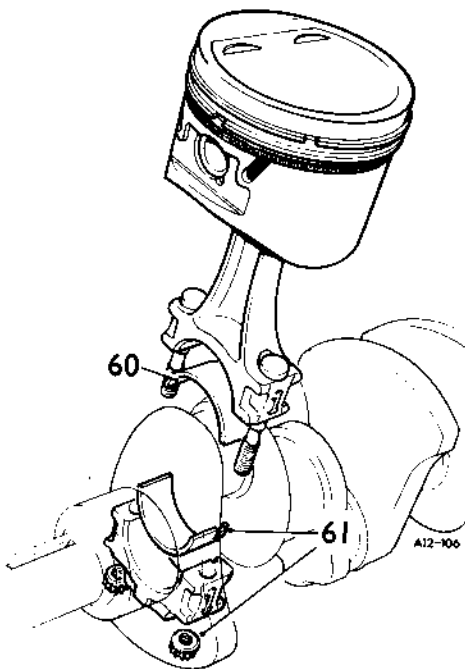

A12-106

- 63 Fit a new seal to the rear main oil seal housing (lip towards the crankshaft) and using a new gasket and jointing compound fit the housing locating it over two dowels. Secure with the six bolts and spring washers noting that the two longer bolts are fitted at the bottom.
- 64 Fit the rear adaptor plate locating it on two dowels and secure with the six bolts.
- 65 Fit the spigot bush to the crankshaft.
- 66 Fit the flywheel – lining up the punch marks – if the original flywheel or crankshaft is being refitted.
- 67 Secure with the spigot bush retaining plate and eight bolts and tighten to the correct torque – see 'TORQUE WRENCH SETTINGS'.
- 68 Check the flywheel for run-out using a dial gauge – see DATA.

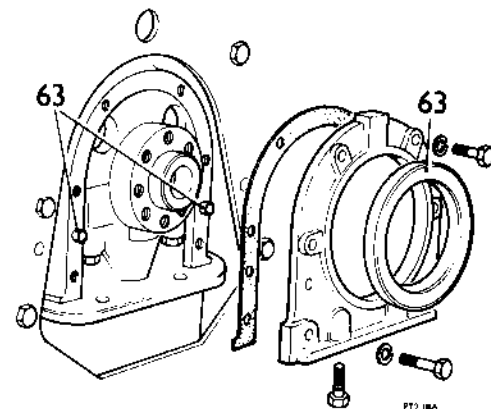

P12-186

*continued*

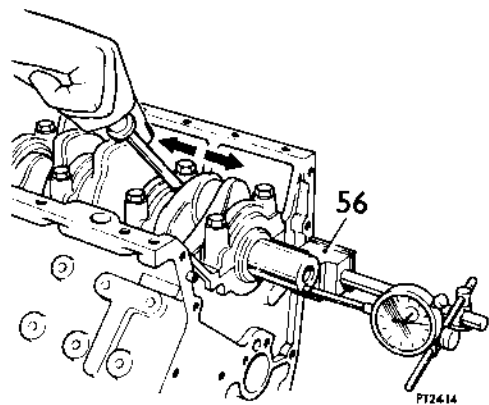

P12414

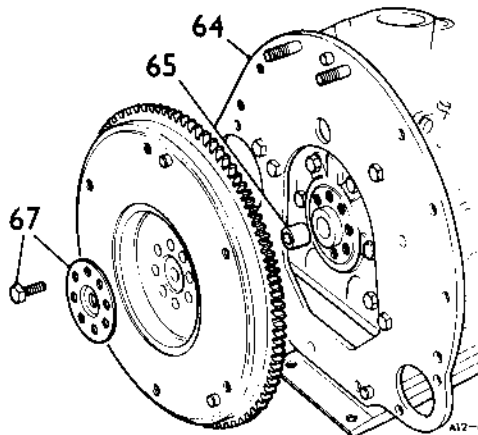

A12-6

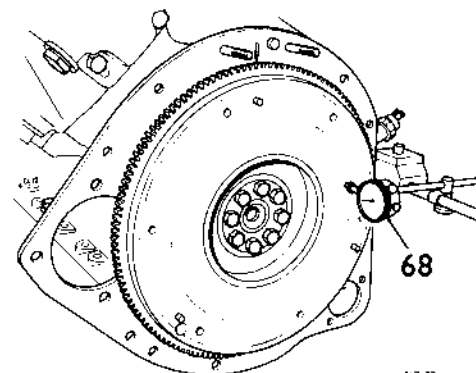

A12-33

- 69 Fit the clutch driven and pressure plates locating the pressure plate assembly over the three dowels.
- 70 Centralize the driven plate using a dummy primary shaft and evenly tighten the six bolts and spring washers to the correct torque. See 33.10.01.
- 71 Fit the sprocket to the jackshaft locating it over the single dowel and secure with bolt and new lock washer.
- 72 Fit the jackshaft to the cylinder block, locate it with the keeper plate and secure the plate with the two Allen screws.
- 73 Fit the water pump impeller and cover assembly checking the clearance as described in the refitting instructions. 26.50.01.
- 74 Fit the oil transfer adaptor ensuring that new 'O' rings are fitted and correctly located. Secure with the single bolt.
- 75 Ensure that the pistons are not at T.D.C. see cautionary note below.
- 76 Fit two 'slave' guide studs to the bolt holes in the cylinder block to facilitate the fitting of the cylinder head and gasket.

**NOTE:** See 12.29.02 for dimensional drawing of suitable studs.

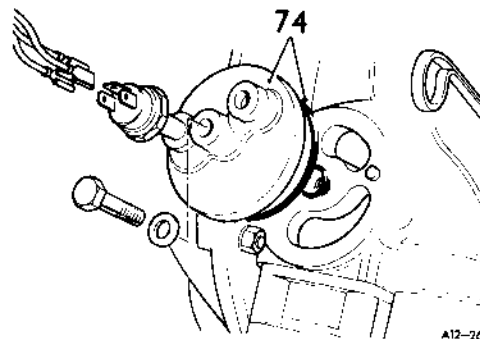
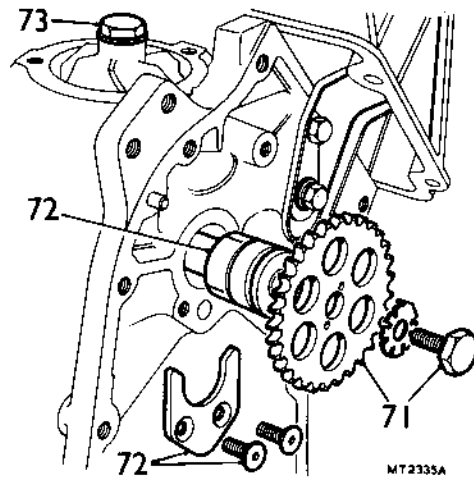

- 77 Fit the cylinder head gasket locating it over the studs.
- 78 Fit the cylinder head easing it over the guide studs.
- 79 Fit the five cylinder head studs.
- 80 Remove the two 'slave' studs and fit the five cylinder head retaining bolts and plain washers.
- 81 Fit the nuts and plain washers to the cylinder head studs.
- 82 Tighten the nuts and bolts to the correct torque and in the correct sequence. 12.29.27.

**CAUTION:** Once the pistons are fitted care must be taken to ensure that the crankshaft is not allowed to turn a complete revolution until the valve timing has been completed, otherwise damage to the valves and pistons will occur.

- 83 Temporarily fit the crankshaft sprocket and check its alignment with the jackshaft sprocket by placing a straight edge across the two sprockets.
- 84 Adjust any misalignment by removing the crankshaft sprocket and fitting shims of suitable thickness between it and the crankshaft. Ensure that the sprocket is pushed fully home when checking the alignment.
- 85 Remove the sprocket, fit the crankshaft drive key and refit the sprocket.

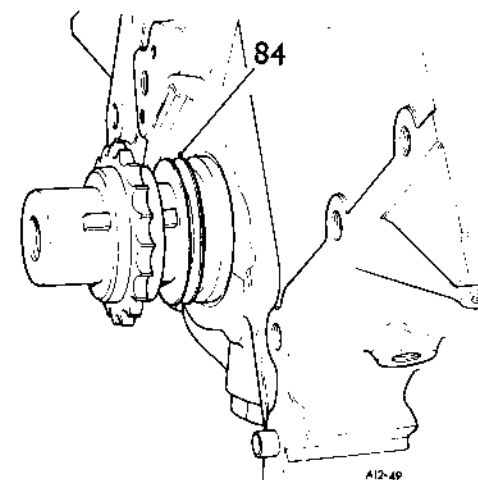
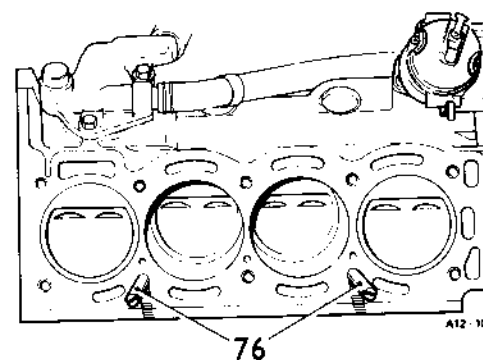
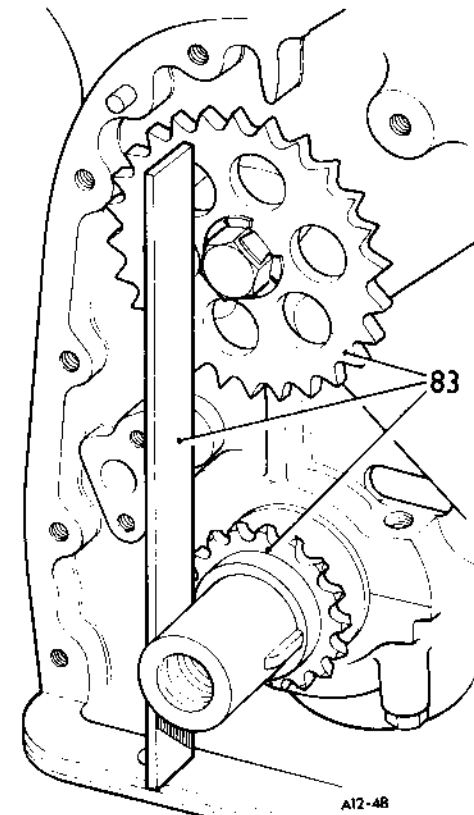

- 86 Turn the camshaft until the timing mark on the flange is in line with the groove on the camshaft front bearing cap.
- 87 Temporarily locate the timing cover and crankshaft pulley and turn the crankshaft (having regard for the above CAUTION) until number 1 and 4 pistons are at T.D.C. Remove the pulley and timing cover.
- 88 Turn the jackshaft until the scribed line across the sprocket is equidistant between bolt A and hole B with the dowel to the left. Remove the pulley and timing cover.
- 89 Encircle the camshaft sprocket with the timing chain and insert through the cylinder head aperture. Locate the sprocket on the camshaft flange and secure with the lock plate and one bolt.
- 90 Keeping the chain taut on the drive side (i.e. the run between the camshaft and crankshaft sprockets) fit the chain to the crankshaft and jackshaft sprockets. Check and if necessary make any adjustment to the position of the jackshaft sprocket to maintain it in its correct position as in instruction 88.
- 91 Fit and loosely secure the guides as follows:
  - a The adjustable guide.
  - b The straight fixed guide.
  - c The support bracket.
- 92 Fit a 'slave' bolt to the lower hole in the fixed guide to ensure alignment when fitting the timing cover centre bolt.
- 93 Fit the timing chain hydraulic tensioner and secure with the two bolts and spring washers. 12.65.28.

**NOTE:** To prevent the tensioner releasing while fitting, fit a spacer between the tensioner body and the back of the slipper.

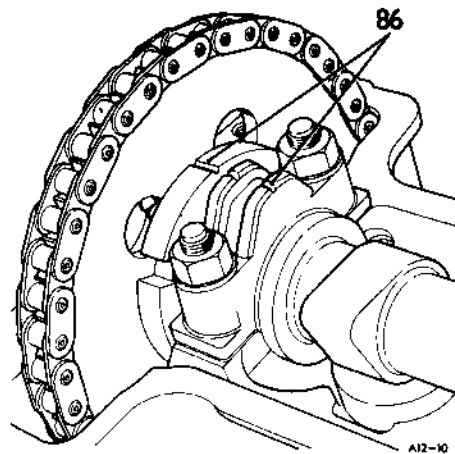

A12-10

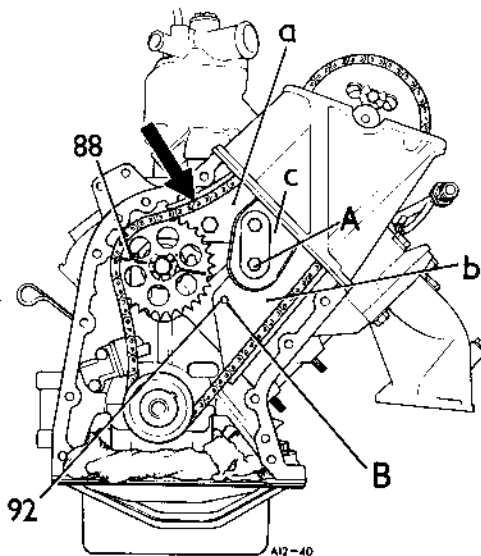

A12-40

- 94 Remove the spacer and insert a 0.100 in (2,54 mm) feeler gauge or slip gauge in its place, dimension A.
- 95 Adjust the chain tension by applying pressure, in the direction of the arrow, to the adjustable guide while tightening the clamp bolt.
- 96 Remove the gauge and check that the scribed line on the jackshaft sprocket is still correctly positioned.
- 97 Tighten all the guide retaining bolts and remove the 'slave' bolt.
- 98 Turn the engine sufficiently to enable the remaining camshaft sprocket retaining bolt to be fitted and locked.
- 99 Check that the threaded spigot on the camshaft sprocket does not foul the support bracket.
- 100 Fit the oil thrower with the dished face outwards.
- 101 Using sealing compound fit a new timing cover gasket and position the timing cover over the two dowels.
- 102 Secure the cover with the centre bolt noting that it has a fibre washer under the head.
- 103 Fit the two nuts and bolts retaining the timing cover to the cylinder head.
- 104 With the lip face leading press-in a new timing cover oil seal flush with the outer face of the cover.

*continued*

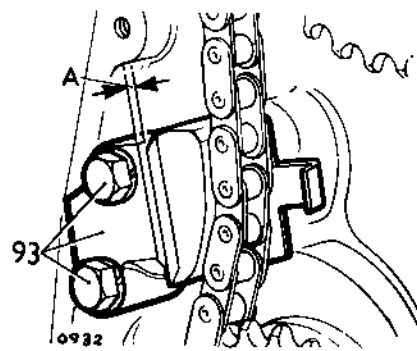

0932

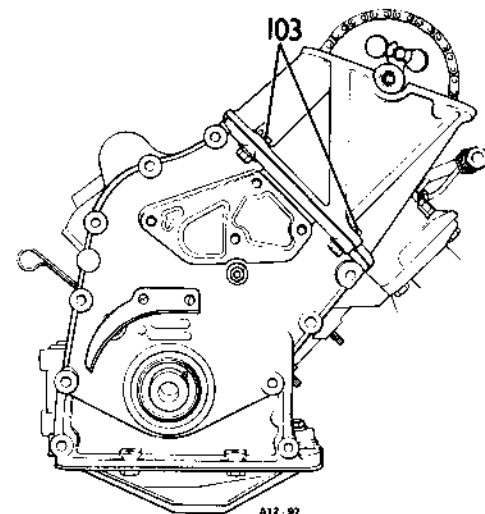

A12-97

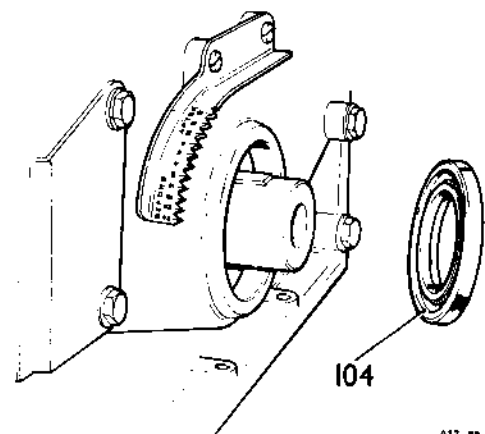

A12-98



- 105 Fit the crankshaft pulley.
- 106 Turn the crankshaft to bring numbers 1 and 4 pistons to T.D.C. with the timing mark on the camshaft flange in line with the groove on the front bearing cap.
- 107 Fit the distributor so that the vacuum advance unit is pointing directly rearward and the rotor arm is in line with the manifold rear retaining bolt hole in the cylinder head.
- 108 Temporarily tighten the distributor retaining bolts pending final adjustment when the engine is installed.
- 109 Fit the camshaft cover.
- 110 Fit the oil pick-up strainer.
- 111 Fit the sump.
- 112 Fit the fuel pump using a new gasket and ensuring that the actuating lever rides on top of the jackshaft cam.
- 113 Fit the fan pulley assembly and the drive belt on the pulley.
- 114 Fit the alternator complete with bracket and adjusting link.
- 115 Fit the front lifting eye.
- 116 Fit and adjust the alternator belt tension. 86.10.05.
- 117 Fit the exhaust manifold.
- 118 Fit the hexagon drive and oil pump using a new sealing ring.
- 119 Fit the oil pressure switch.
- 120 Insert a new filter element in the filter bowl and fit the assembly with a new sealing rubber.
- 121 Fit the R.H. engine mounting bracket noting that the long bolts are fitted to the top two holes.
- 122 Fit the water pump to heater and inlet manifold pipe and hose.
- 123 Fit the bottom hose to the water pump cover.

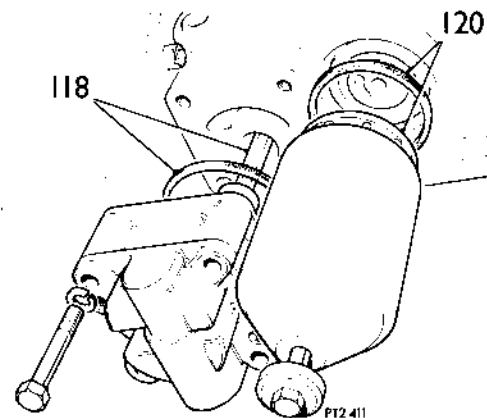
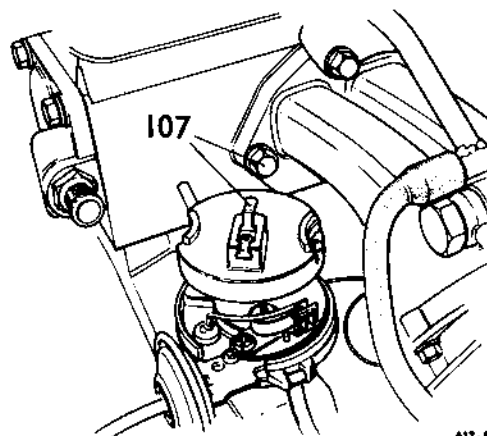

- 124 Fit the inlet manifold complete with carburetters 19.15.15 and the rear lifting eye.
- 125 Connect the fuel pump to carburetter hose.
- 126 Connect the engine breather pipes.
- 127 Fit the dipstick.
- 128 Fit the spark plugs.
- 129 Fit the distributor cap and connect the H.T. leads to the plugs (firing order 1, 3, 4, 2 distributor turns anti-clockwise).
- 130 Fit the gearbox.
- 131 Fit the starter motor.
- 132 Fit the engine and gearbox assembly to the car 12.37.01.
- 133 Check and if necessary adjust the ignition timing 86.35.15.

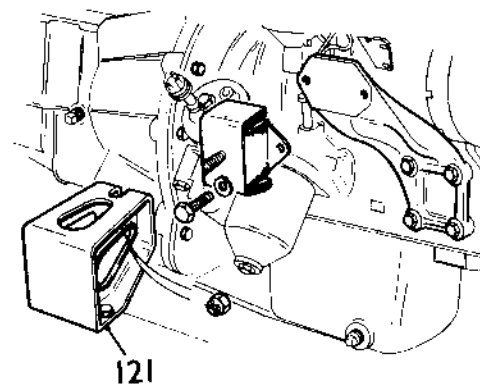

## ENGINE ASSEMBLY – USA & Canada Specification

Strip and rebuild 12.41.05

Special tool: 38 U3

### Stripping

- 1 Remove the engine and gearbox assembly from the car 12.37.01 and drain the sump.
- 2 Remove the gearbox – noting the position of the remaining bolts for refitting.
- 3 Drain the cylinder block.
- 4 Remove the starter motor.
- 5 Remove the clutch.
- 6 Remove the inlet manifold complete with carburetters and air cleaner.
- 7 Remove the water pump and remove the bottom hose.
- 8 Remove the fuel pump.
- 9 Remove the distributor.
- 10 Remove the R.H. engine mounting bracket.
- 11 Remove the alternator complete with bracket.
- 12 Remove the alternator link.
- 13 Remove the air distribution manifold complete with diverter and relief valve, check valve and hoses.
- 14 Remove the exhaust manifold.

- 15 Remove the air conditioning compressor – where fitted – complete with brackets.
- 16 Remove the air pump.
- 17 Remove the fan pulley and torquatrol assembly.
- 18 Remove the water pump.
- 19 Remove the spark plugs.
- 20 Remove the flywheel – 12.53.07 instructions 4 to 6.
- 21 Remove the oil pressure switch.
- 22 Remove the dipstick.
- 23 Remove the auxiliary and crankshaft pulleys. 12.21.01.
- 24 Remove the front lifting eye.
- 25 Remove the oil filter bowl and sealing ring.
- 26 Remove the oil pump and hexagon drive.
- 27 Remove the oil transfer housing.
- 28 Withdraw the six bolts and remove the rear adaptor plate.
- 29 Remove the camshaft cover.
- 30 Unlock and remove one of the camshaft sprocket retaining bolts.
- 31 Anchor the sprocket with a 'slave' nut to the support bracket and unlock and remove the remaining bolt.
- 32 Remove the two nuts and bolts securing the timing cover to the cylinder head.

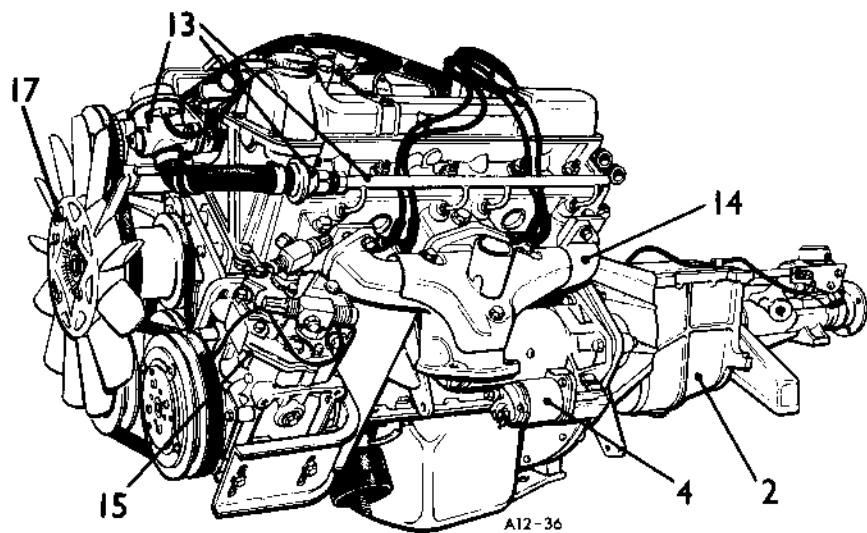

A12-36

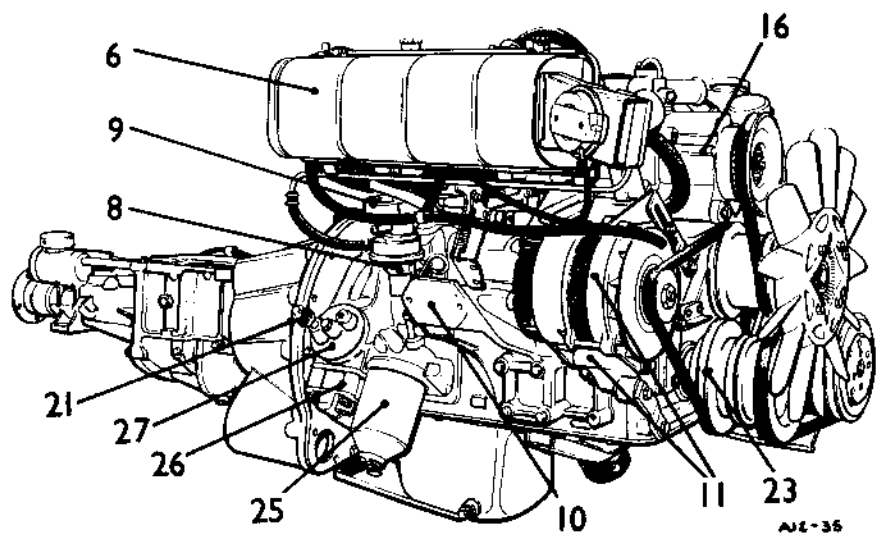

A12-35

- 33 Slacken the cylinder head retaining nuts and bolts in the reverse order as shown in operation 12.29.27.
- 34 Remove the five cylinder head studs and five bolts.
- 35 Withdraw the cylinder head complete with the camshaft and discard the gasket.
- 36 Remove the sump.
- 37 Remove the oil pick-up strainer.
- 38 Withdraw the remaining bolts — noting their positions and remove the timing cover. Remove the oil seal.
- 39 Remove the oil thrower.
- 40 Remove the two retaining bolts and withdraw the timing chain tensioner.
- 41 Remove the three bolts securing the two chain guides and support bracket.
- 42 Remove the guides and support bracket complete with the chain and camshaft sprocket.
- 43 Turn the jackshaft sprocket to expose the two Allen screws retaining the jackshaft keeper plate. Remove the screws and withdraw the plate.
- 44 Withdraw the jackshaft and sprocket from the cylinder block.
- 45 Unlock the tab washer and remove the bolt and sprocket from the jackshaft.
- 46 Withdraw the crankshaft sprocket.
- 47 Remove the drive key and shims from the crankshaft.
- 48 Remove the six bolts and remove the rear main oil seal and housing.
- 49 Remove the nuts securing the connecting rod bearing caps and withdraw the caps and lower shells ensuring that if the shells are to be refitted they are kept identified with their respective caps.
- 50 Push the connecting rods upwards and withdraw the piston assemblies through the top of the bores, keeping the shells identified with their respective connecting-rods.
- 51 Remove the 10 bolts securing the five main bearing caps and withdraw the caps and lower shells.
- 52 Lift out the crankshaft.
- 53 Remove the upper shells from the crankcase.
- 54 Remove the thrust washers from number 3 main bearing.
- 55 Withdraw the spigot bush from the crankshaft.

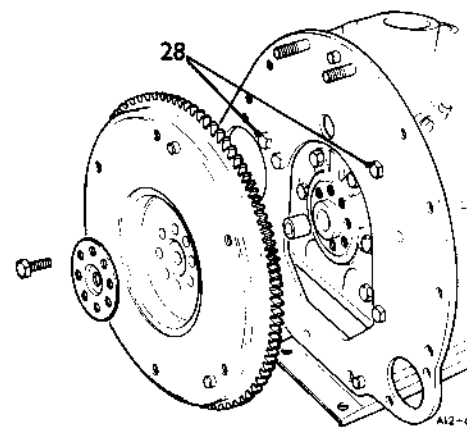

A12-4

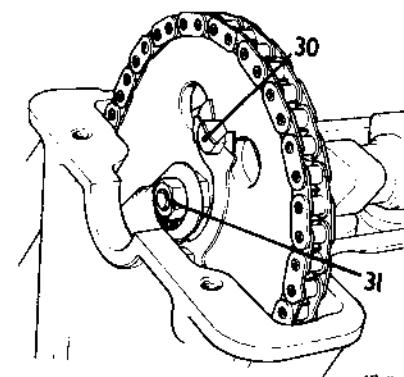

A12-11

*continued*

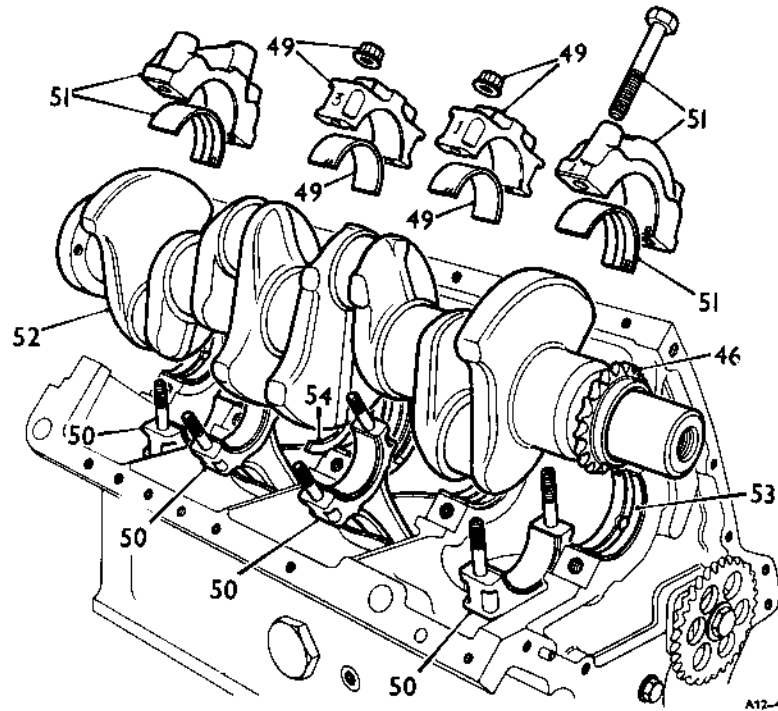
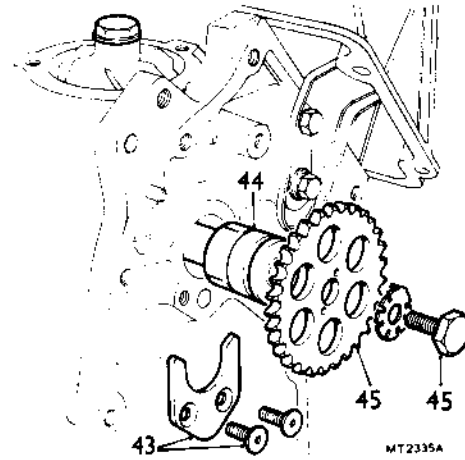
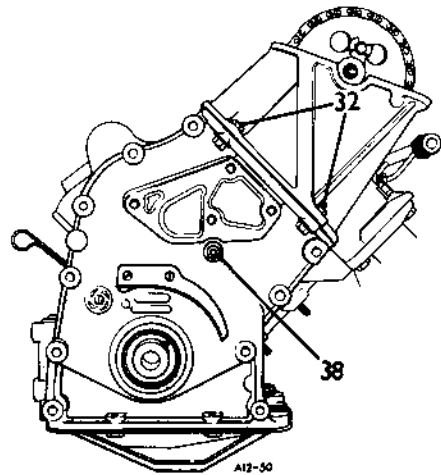
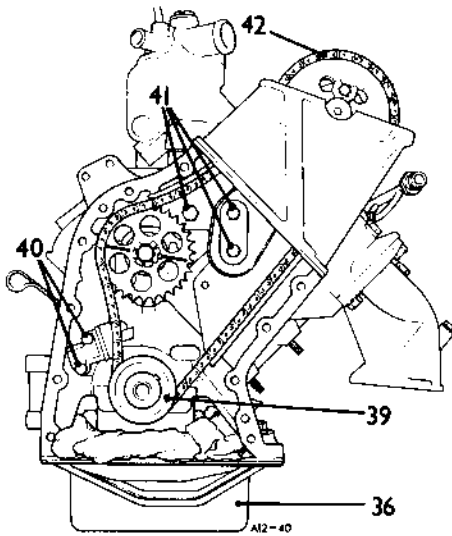

### Rebuilding

**NOTE:** The following rebuilding instructions assume that all the individual components and assemblies have been examined, worn parts renewed and assemblies overhauled. Moreover, all joint faces are clean and parts lubricated before assembly.

- 56 Fit the five main bearing upper shells ensuring that the keeper tags locate in the recesses.
- 57 Fit the crankshaft thrust washers to number 3 main bearing noting that the oil grooves face outwards.
- 58 Lower the crankshaft into the crankcase.
- 59 Fit the lower shells to the main bearing caps and fit them to the crankcase. Partially tighten the securing bolts.

- 60 Using either a dial gauge or feelers check the crankshaft end-float – see DATA.
- 61 Tighten the main bearing cap bolts to the correct torque – see section 06.
- 62 Stagger the piston ring gaps, avoiding a gap on the thrust side and compress the rings using special tool number 38 U3.
- 63 Turn the crankshaft to position numbers 2 and 3 crankpins at B.D.C. Insert the respective connecting rod and piston assemblies into the bores and tap the pistons home noting that the flat raised part of the piston crown is fitted to the L.H. side of the engine.
- 64 Fit the upper bearing shells to the connecting rods ensuring that the keeper tags locate in the recesses and pull the connecting rods onto the journals.
- 65 Fit the lower shells to the connecting rod caps ensuring that the keeper tags locate in the recesses and fit them to the connecting rods. Tighten new nuts to the correct torque – see 'TORQUE WRENCH SETTINGS'.
- 66 Repeat instructions 62 to 65 on numbers 1 and 2 pistons and connecting rod assemblies.

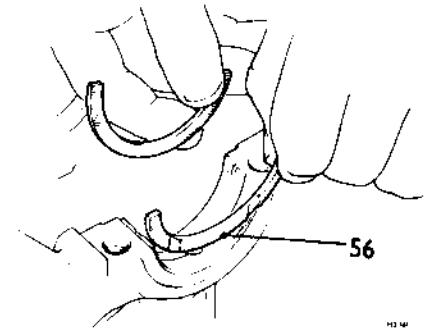

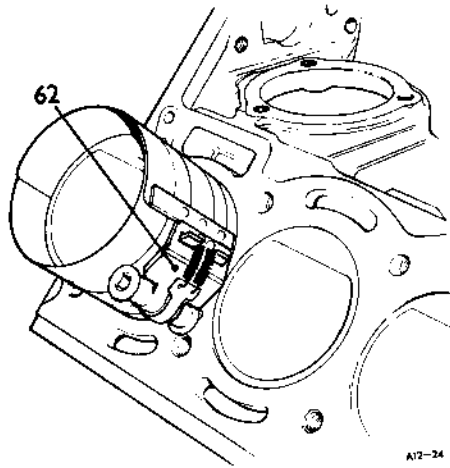

67 Fit a new seal to the rear main oil seal housing (lip towards the crankshaft) and using a new gasket and jointing compound fit the housing locating it over two dowels. Secure with the six bolts and spring washers noting that the two longer bolts are fitted at the bottom.

68 Fit the rear adaptor plate locating it on two dowels and secure with the six bolts.

69 Fit the spigot bush to the crankshaft.

70 Fit the flywheel – lining up the punch marks – if the original flywheel or crankshaft is being fitted. Secure with the spigot bush retaining plate and eight bolts and tighten to the correct torque – see 'TORQUE WRENCH SETTINGS'.

71 Check the flywheel run-out using a dial gauge – see DATA.

72 Fit the clutch driven and pressure plates locating the pressure plate assembly over the three dowels.

73 Centralize the driven plate using a dummy primary shaft and evenly tighten the six bolts and spring washers to the correct torque. See 33.10.01.

74 Fit the sprocket to the jackshaft locating it over the single dowel and secure with bolt and new lock washer.

75 Fit the jackshaft to the cylinder block, locate it with the keeper plate and secure the plate with the two Allen screws.

76 Fit the water pump impeller and cover assembly checking the clearance as described in the refitting instructions 26.50.01.

77 Fit the distributor mounting plate.

78 Fit the oil transfer adaptor ensuring that new 'O' rings are fitted and correctly located. Secure with the single bolt.

79 Ensure that the pistons are not at T.D.C. see cautionary note.

80 Fit two 'slave' guide studs to the bolt holes in the cylinder block to facilitate the fitting of the cylinder head and gasket.

**NOTE:** See 12.29.02 for dimensional drawing of suitable studs.

81 Fit the cylinder head gasket locating it over the studs.

82 Fit the cylinder head easing it over the guide studs.

83 Fit the five cylinder head studs.

84 Remove the two 'slave' studs and fit the five cylinder head retaining bolts and plain washers.

85 Fit the nuts and plain washers to the cylinder head studs.

86 Tighten the nuts and bolts to the correct torque and in the correct sequence. See 12.29.27.

**CAUTION:** Once the pistons are fitted care must be taken to ensure that the crankshaft is not allowed to turn a complete revolution until the valve timing has been completed, otherwise damage to the valves and pistons will occur.

87 Temporarily fit the crankshaft sprocket and check its alignment with the jackshaft sprocket by placing a straight edge across the two sprockets.

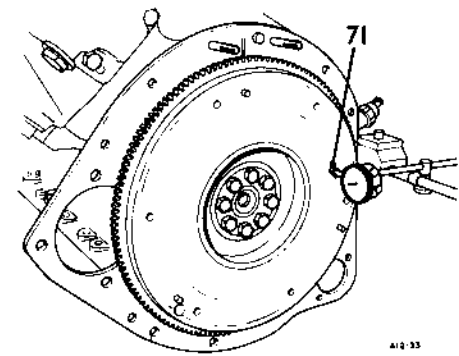
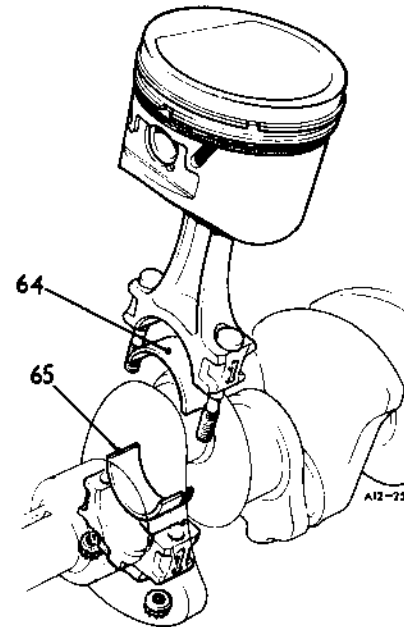
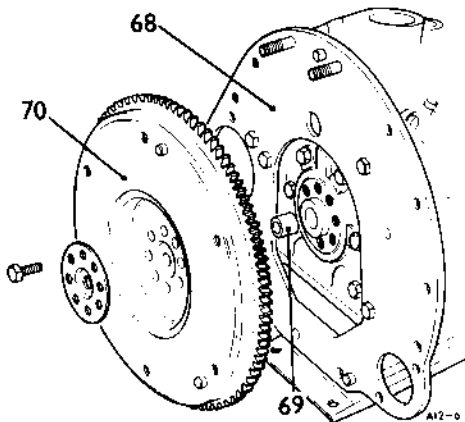
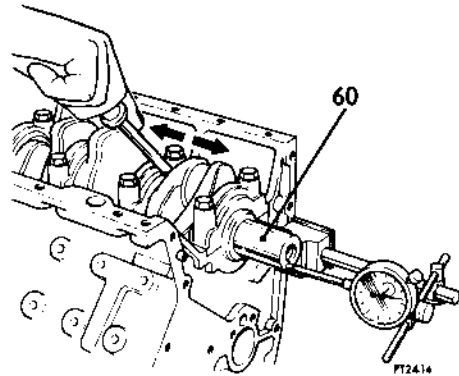
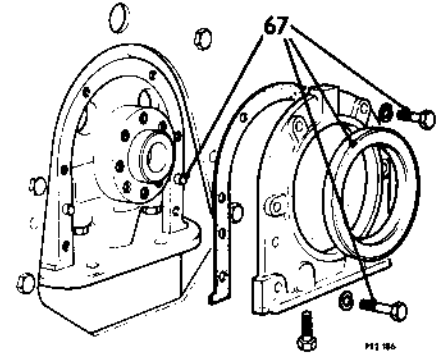

continued

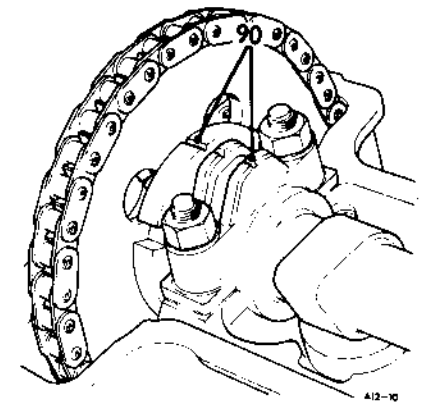
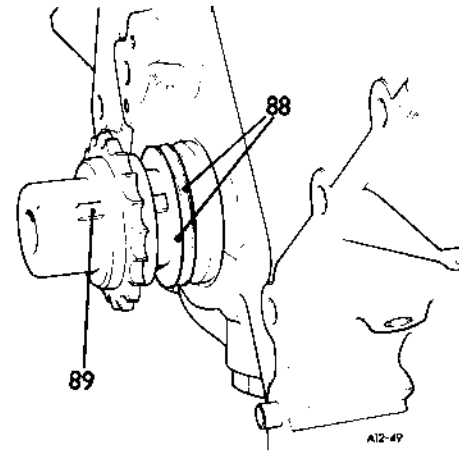
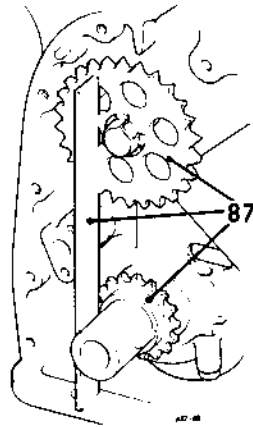
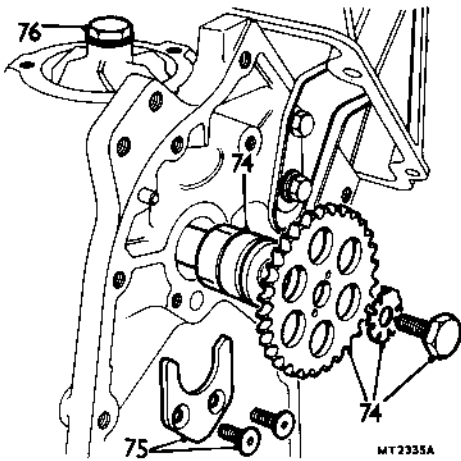
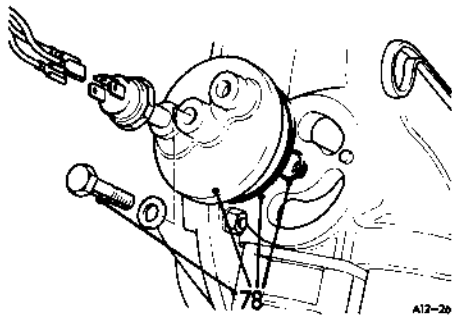

- 88 Adjust any misalignment by removing the crankshaft sprocket and fitting shims of suitable thickness between it and the crankshaft. Ensure that the sprocket is pushed fully home when checking the alignment.
- 89 Remove the sprocket, fit the crankshaft drive key and refit the sprocket.
- 90 Turn the camshaft until the timing mark on the flange is in line with the groove on the camshaft front bearing cap.
- 91 Temporarily locate the timing cover and crankshaft pulley and turn the crankshaft (having regard for the preceding CAUTION) until number 1 and 4 pistons are at T.D.C. Remove the pulley and timing cover.
- 92 Turn the jackshaft until the scribed line across the sprocket is equidistant between bolt A and hole B with the dowel to the left. Remove the pulley and timing cover.
- 93 Encircle the camshaft sprocket with the timing chain and insert through the cylinder head aperture. Locate the sprocket on the camshaft flange and secure with the lock plate and one bolt - instruction 30.

- 94 Keeping the chain taut on the drive side fit the chain to the crankshaft and jackshaft sprockets. Check and if necessary make any adjustment to the position of the jackshaft sprocket to maintain it in its correct position as in instruction 92.
- 95 Fit and loosely secure the guides as follows:
- The adjustable guide.
  - The straight fixed guide.
  - The support bracket.
- 96 Fit a 'slave' bolt to the lower hole in the fixed guide to ensure alignment when fitting the timing cover centre bolt.
- 97 Fit the timing chain hydraulic tensioner and secure with the two bolts and spring washers, 12.65.28.

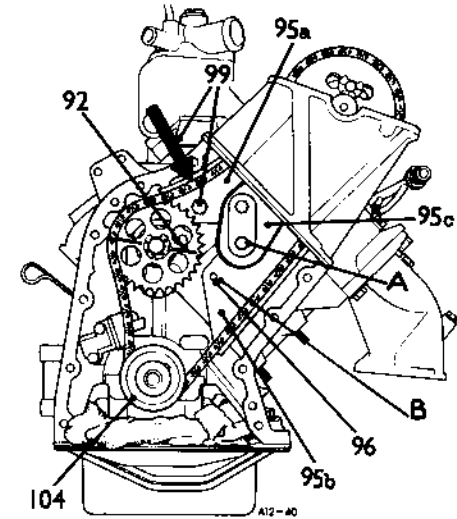

**NOTE:** To prevent the tensioner releasing while fitting, fit a spacer between the tensioner body and the back of the slipper.

- 98 Remove the spacer and insert a 0.100 in (2,54 mm) feeler gauge or slip gauge in its place, dimension A.

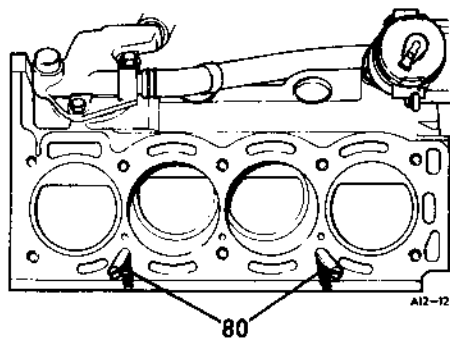
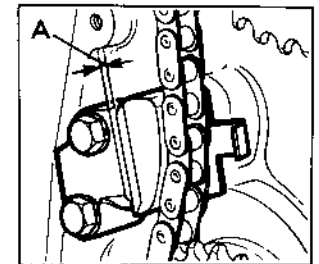

- 99 Adjust the chain tension by applying pressure, in the direction of the arrow, to the adjustable guide while tightening the clamp bolt.
- 100 Remove the gauge and check that the scribed line on the jackshaft sprocket is still correctly positioned.
- 101 Tighten all the guide retaining bolts and remove the 'slave' bolt.
- 102 Turn the engine sufficiently to enable the remaining camshaft sprocket retaining bolt to be fitted and locked.
- 103 Check that the threaded spigot on the camshaft sprocket does not foul the support bracket.
- 104 Fit the oil thrower with the dished face outwards.
- 105 Using sealing compound fit a new timing cover gasket and position the timing cover over the two dowels.
- 106 Secure the cover with the centre bolt noting that it has a fibre washer under the head.
- 107 Fit the two nuts and bolts retaining the timing cover to the cylinder head.
- 108 Wit the lip face leading press-in a new timing cover oil seal flush with the outer face of the cover.
- 109 Fit the crankshaft and auxiliary pulleys.
- 110 Turn the crankshaft to bring numbers 1 and 4 pistons to T.D.C. with the timing mark on the camshaft flange in line with the groove on the front bearing cap.
- 111 Fit the distributor so that the vacuum retard unit is pointing directly rearward and the rotor arm is in line with the manifold rear retaining bolt hole in the cylinder head.
- 112 Temporarily tighten the distributor retaining bolts pending final adjustment when the engine is installed.
- 113 Fit the camshaft cover.
- 114 Fit the oil pick-up strainer.
- 115 Fit the sump.
- 116 Fit the fuel pump using a new gasket and ensuring that the actuating lever rides on top of the jackshaft cam.
- 117 Fit the fan pulley assembly and hang the drive belts on the pulleys.
- 118 Fit the alternator complete with bracket and adjusting link.
- 119 Fit the front lifting eye.
- 120 Fit the air pump.

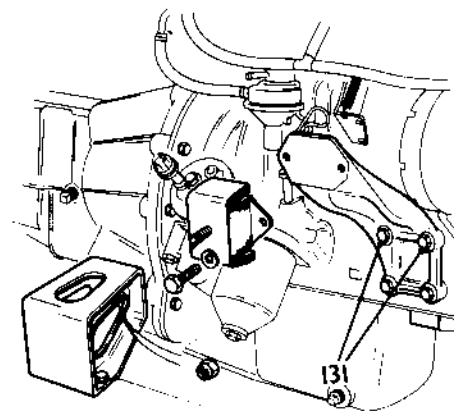
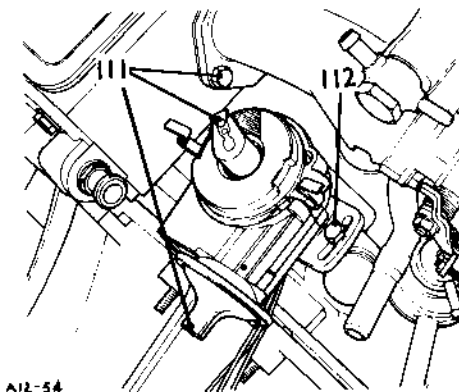
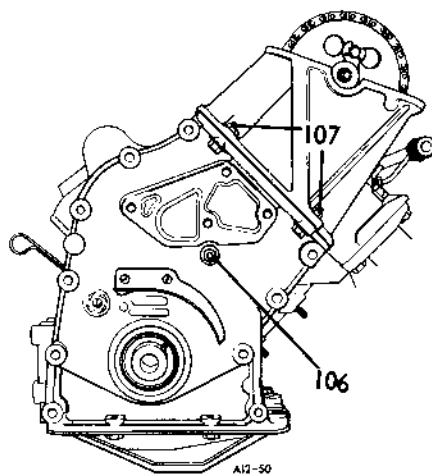
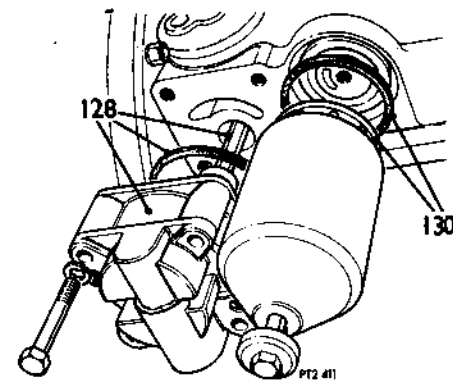
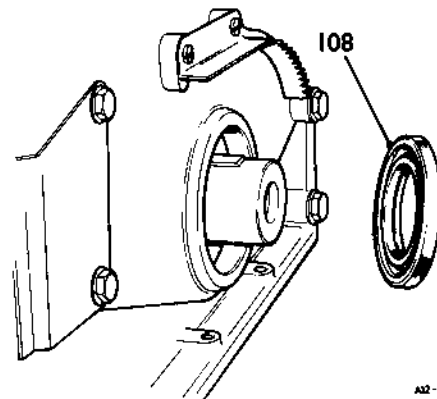
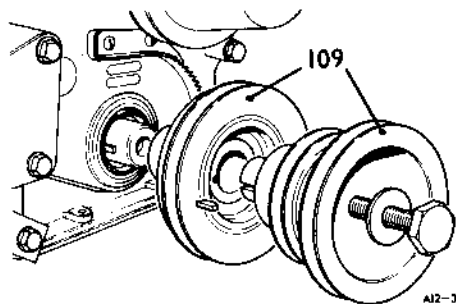

continued

- 121 Fit the diverter and relief valve complete with the air distribution manifold and hoses.
- 122 Fit the air pump to diverter and relief valve hose.
- 123 Fit and adjust the air pump drive belt tension 17.25.13 instructions 4 to 6.
- 124 Fit and adjust the alternator belt tension 86.10.05.
- 125 Install the air compressor and brackets - if fitted.
- 126 Adjust air compressor drive belt tension 82.10.01.
- 127 Fit the exhaust manifold.
- 128 Fit the hexagon drive and oil pump using a new sealing ring.
- 129 Fit the oil pressure switch.
- 130 Insert a new filter element in the filter bowl and fit the assembly with a new sealing rubber.
- 131 Fit the R.H. engine mounting bracket noting that the long bolts are fitted to the top two holes.
- 132 Fit the water pump to heater and inlet manifold pipe and hose.
- 133 Fit the bottom hose to the water pump cover.
- 134 Fit the inlet manifold complete with carburetters 19.15.15 instructions 19 to 23 and the rear lifting eye.
- 135 Connect the fuel pump to carburetter hose.
- 136 Connect the engine breather pipes.
- 137 Fit the dipstick.
- 138 Fit the spark plugs.
- 139 Fit the distributor cap and connect the H.T. leads to the plugs (firing order 1, 3, 4, 2 distributor turns anti-clockwise).
- 140 Connect the vacuum pipe to the diverter and relief valve.
- 141 Fit the gearbox.
- 142 Fit the starter motor.
- 143 Fit the engine and gearbox assembly to the car 12.37.01.
- 144 Check and if necessary adjust the ignition timing 86.35.15.

## ENGINE MOUNTING - FRONT L.H.

Remove and refit 12.45.01

### Removing

- 1 Disconnect the battery.
- 2 Remove the fan guard.
- 3 Remove the fresh air duct. 80.15.31.
- 4 Raise the car on a ramp.
- 5 Remove the engine stabilizer. 12.45.16.
- 6 Remove the single nut securing the engine mounting to the sub-frame.
- 7 Place a jack to support the engine, under the sump coupling plate.
- 8 Remove the engine R.H. mounting retaining nut.
- 9 Jack up the engine sufficiently to enable the L.H. rubber mounting to be unscrewed from the sump cross-member threaded hole.
- 10 Remove the mounting.
- 11 Remove the packing piece - where fitted.

### Refitting

- 12 Screw the mounting into the sump cross-member, inserting the packing piece - where fitted.
- 13 Lower the jack and tighten the engine R.H. mounting nut.
- 14 Remove the jack and fit and tighten the single nut securing the L.H. engine mounting to the sub-frame.
- 15 Fit and adjust the engine stabilizer. 12.45.16.
- 16 Lower the ramp.
- 17 Fit the fan guard.
- 18 Fit the fresh air duct. 80.15.31.
- 19 Connect the battery.

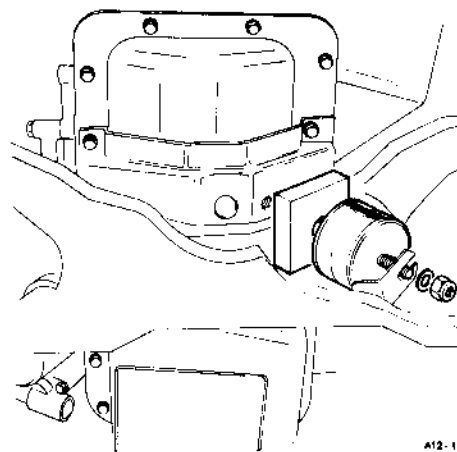

A12-110

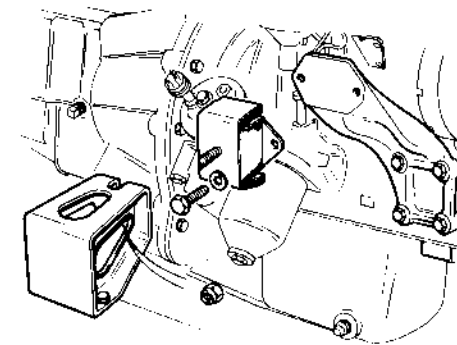

A12-96

## ENGINE MOUNTING - FRONT R.H.

Remove and refit 12.45.03

### Removing

- 1 Disconnect the battery.
- 2 Support the weight of the engine under the sump coupling plate.
- 3 Remove the single nut securing the mounting to the body bracket.
- 4 Remove the two bolts retaining the rubber mounting to the engine bracket.
- 5 Withdraw the mounting.

### Refitting

- 6 Fit the mounting to the engine bracket with the two bolts and spring washers.
- 7 Secure the mounting to the body bracket with the single nut and plain washer.
- 8 Remove the engine support.
- 9 Connect the battery.

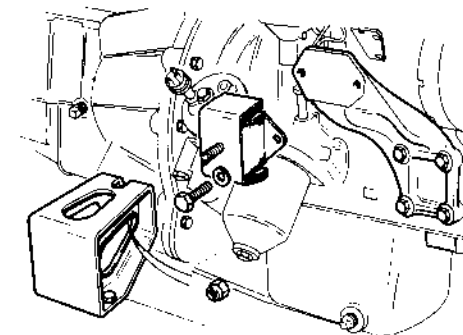

A12-98

## ENGINE MOUNTING – REAR CENTRE – UK and Europe Specification

Remove and refit 12.45.08

### Removing

- 1 Drive the car onto a ramp and disconnect the battery.
- 2 Raise the ramp and place a jack in support under the gearbox.
- 3 Remove the two nuts and bolts retaining the rear mounting assembly to the gearbox extension.
- 4 Remove the two distance plates.
- 5 Remove the four bolts retaining the mounting cross-member to the body and remove the assembly from the car.
- 6 Remove the centre bolt and nut washer.
- 7 Remove the bracket.
- 8 Remove the distance piece.
- 9 Remove the restrictor plate.
- 10 Remove the two nuts and bolts securing the rubber mounting to the cross-member.
- 11 Remove the rubber mounting rubber from the cross-member.

### Refitting

- 12 Fit the rubber mounting to the cross-member with the two nuts and bolts.
- 13 Reverse instructions 6 to 9 leaving the centre bolt and nut slack.
- 14 Fit the rear mounting assembly to the gearbox extension with the two nuts and bolts and four plain washers (one under the head of each bolt and one under the nut). Ensure that the two distance plates are fitted between the bracket and gearbox extension.
- 15 Fit the cross-member to the body with the four nuts.
- 16 Tighten the centre nut and bolt.
- 17 Remove the jack, lower the car and connect the battery.

## ENGINE MOUNTING – REAR CENTRE – USA and Canada Specification

Remove and refit 12.45.08

### Removing

- 1 Drive the car onto a ramp and disconnect the battery.
- 2 Raise the ramp and place a jack in support under the gearbox.
- 3 Disconnect the restraint cable from the crossmember.
- 4 Remove the two nuts securing the mounting assembly to the gearbox extension.
- 5 Disconnect the tie bar from the sump coupling plate.
- 6 Remove the four bolts retaining the mounting crossmember to the body and remove the assembly from the car, complete with the tie bar.
- 7 Remove the centre bolt.
- 8 Remove the tie bar.
- 9 Remove the distance piece.
- 10 Remove the restrictor plate.
- 11 Remove the two nuts and bolts securing the rubber mounting to the cross-member.

### Refitting

- 12 Fit the rubber mounting to the cross-member with the two nuts and bolts.
- 13 Reverse instructions 7 to 11 leaving the centre bolt slack.
- 14 Fit the cross-member to the body with the four nuts.
- 15 Fit the assembly to the gearbox extension with the two nuts.
- 16 Connect the tie bar to the sump coupling plate.
- 17 Tighten the centre bolt.
- 18 Connect and adjust the restraint cable 37.20.01 instruction 29.
- 19 Remove the jack, lower the car and connect the battery.

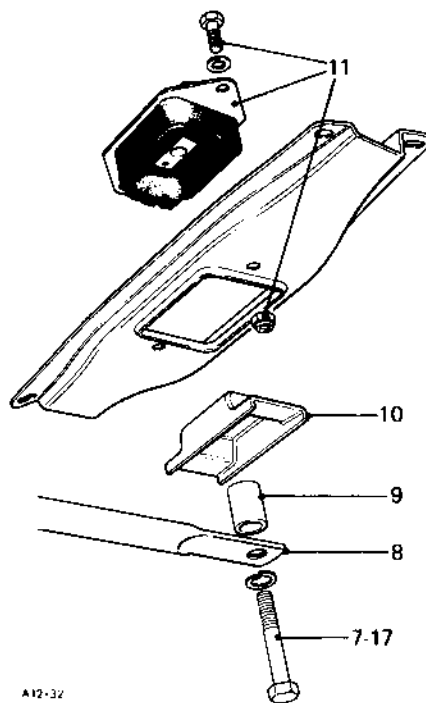
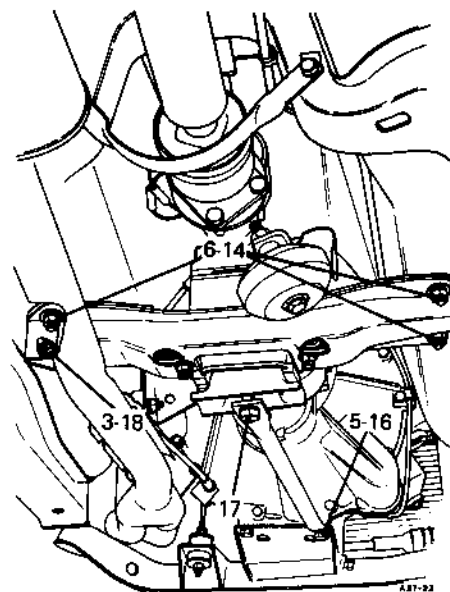

## ENGINE STABILIZER – Early Models

Remove and refit 12.45.16

### Removing

- 1 Raise the car on a ramp.
- 2 Remove the nyloc nut securing the engine stabilizer to the cylinder block bracket.
- 3 Remove the nyloc nut securing the stabilizer to the sub-frame and withdraw:
  - a The lower washer.
  - b The lower rubber.
  - c The nylon distance piece.
- 4 Remove the stabilizer complete with:
  - a The top rubber.
  - b The top washer.
  - c The top retaining nut.
  - d The lock nut.

continued

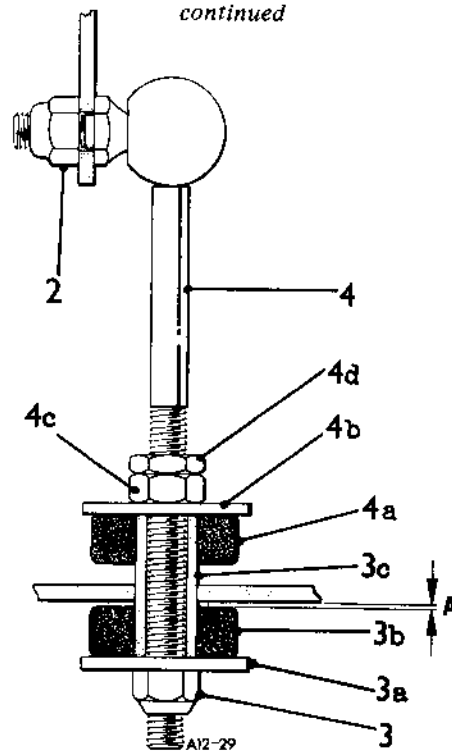

A12-32

A12-29



**Refitting**

- 5 Slacken off the lock nut and upper retaining nut.
- 6 Insert the stabilizer into the sub-frame location complete with the upper retaining nut and its lock-nut and upper washer and rubber.
- 7 Locate the stabilizer in the cylinder block bracket and secure with the nyloc nut.
- 8 Fit the nylon distance piece.
- 9 Fit the lower rubber washer and nyloc nut.
- 10 Tighten the lower nyloc nut until a gap of 0.040 in (1.0 mm) – dimension A – exists between the sub-frame and lower rubber.
- 11 Tighten the top retaining nut down until the upper washer just nips the nylon distance piece and tighten the lock nut.
- 12 Check the dimension A and lower the ramp.

**ENGINE REAR ADAPTOR PLATE**

Remove and refit 12.53.03

**Removing**

- 1 Remove the gearbox. 37.20.01.
- 2 Remove the clutch assembly.
- 3 Remove the flywheel – 12.53.07 – instructions 4 to 6.
- 4 Remove the six bolts securing the adaptor plate to the cylinder block.
- 5 Withdraw the rear adaptor plate.

**Refitting**

- 6 Clean the engine and adaptor plate mating faces and locate the plate on the engine over the dowels and studs.
- 7 Secure the plate with the six bolts.
- 8 Fit the flywheel 12.53.07 – instructions 7 to 11.
- 9 Fit the clutch. 33.10.01.
- 10 Fit the gearbox. 37.20.01.

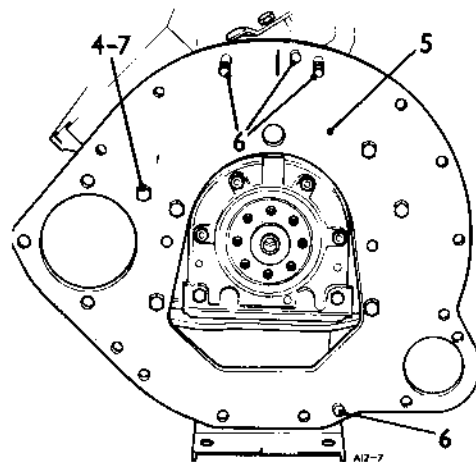
**FLYWHEEL**

Remove and refit 12.53.07

**Removing**

- 1 Isolate the battery.
- 2 Remove the gearbox. 37.20.01
- 3 Remove the clutch assembly. 33.10.01.
- 4 Remove the eight bolts and spigot bush retaining plate.
- 5 Mark for reassembly the relationship between the flywheel hub and crankshaft flange.
- 6 Withdraw the flywheel and ring gear assembly.

**Refitting**

- 7 Locate the flywheel assembly on the crankshaft so that the identification marks line up.
- 8 Secure the flywheel to the crankshaft with the eight bolts and retaining plate. Tighten the bolts to the correct torque – see 'TORQUE WRENCH SETTINGS'.
- 9 If a new flywheel has been fitted, turn the engine over so that numbers 1 and 4 pistons are at T.D.C. with number 1 cylinder firing.
- 10 Mark a chisel mark on the outside edge of the flywheel in line with the vertical mark on the engine rear adaptor plate.
- 11 Using a dial gauge check the flywheel for run-out – see DATA.
- 12 Refit the clutch. 33.10.01.
- 13 Refit the gearbox. 37.20.01.
- 14 Reconnect the battery.

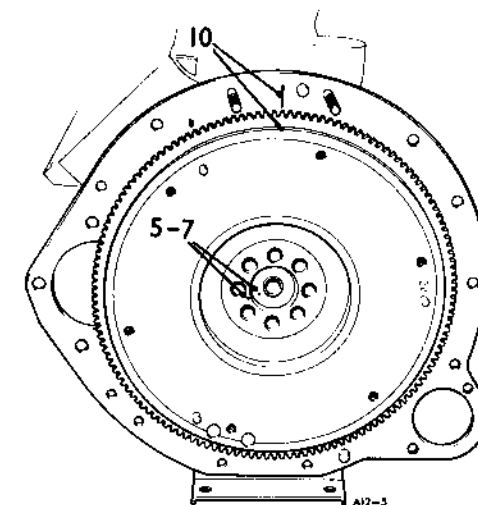
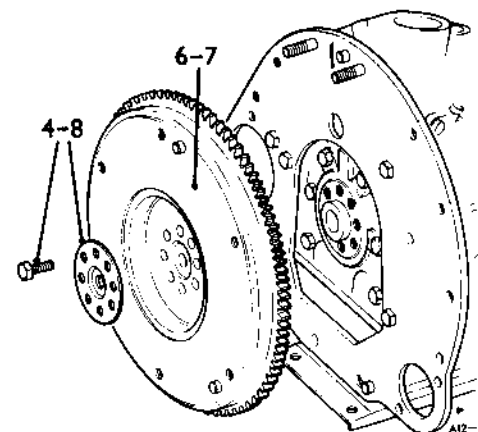
**DATA**

Flywheel run-out maximum . . . . .

0.002 (0,050 mm) at a radius of 4 in (101 mm) on the friction face.

## STARTER RING GEAR

Remove and refit 12.53.19

### Removing

- 1 Remove the flywheel. 12.53.07.
- 2 Drill a hole approximately 0.375 in (10 mm) between the root of any tooth and inner rim of the ring gear. Drill sufficiently to weaken the ring gear without damaging the flywheel.
- 3 Secure the flywheel in a soft-jawed vice.
- 4 Place a heavy cloth over the ring gear for protection against flying fragments when splitting the ring gear.

**WARNING:** Take adequate precaution to avoid injury from flying fragments when splitting the ring gear.

- 5 Place a chisel immediately above the drilled hole and strike sharply to split the gear.

### Refitting

- 6 Place the flywheel friction face downwards on a flat surface.
- 7 Heat the ring gear uniformly between 170° and 175°C (338° to 347°F) but do not exceed this temperature.
- 8 Locate the ring gear on the flywheel and retain it in position until it contracts sufficiently to grip the flywheel.
- 9 Allow the gear to cool gradually to avoid distortion. A maximum permissible gap of 0.025 in (0.6 mm) is allowed between the flywheel and ring gear in any one length of 6 in (15 cm) only of the circumference.
- 10 Fit the flywheel. 12.53.07

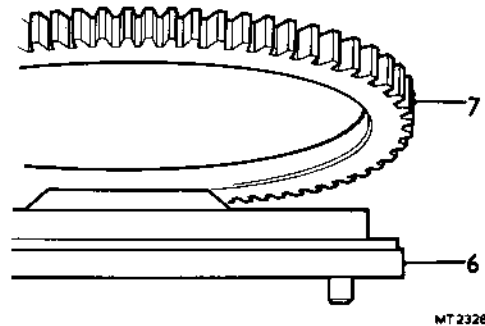
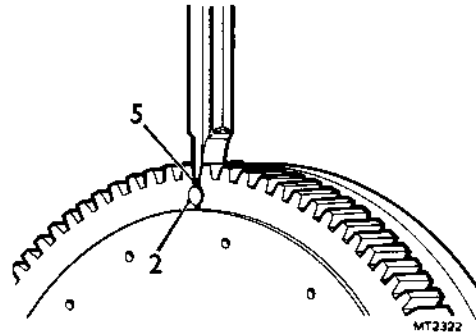

## OIL FILTER ELEMENT

Remove and refit 12.60.02  
Overhauling filter assembly – instructions 6 to 9 12.60.08

### Removing

- 1 Drive the car onto a ramp.
- 2 Disconnect the battery and raise the ramp.
- 3 Place a suitable receptacle under the filter bowl to catch surplus oil.
- 4 Remove the filter bowl centre retaining bolt, and withdraw the assembly.
- 5 Extract the seal from the annular groove in the crankcase.

### Overhauling

- 6 Remove the element and discard.
- 7 Dismantle the centre bolt assembly and clean all components including the bowl.
- 8 Assemble the centre bolt assembly to the bowl as illustrated, using new seals and if necessary renew the spring.
- 9 Secure the assembly with the retaining clip ensuring that it locates properly in the annular groove in the bolt.

### Refitting

- 10 Clean the crankcase mating face and annular groove and fit a new seal to the groove ensuring that it seats properly and is not twisted.
- 11 Insert a new element into the filter bowl and secure the assembly to the crankcase and whilst tightening the centre bolt rotate the bowl to ensure that it seats correctly in the groove. Tighten the bolt to the correct torque – see 'TORQUE WRENCH SETTINGS'.
- 12 Reconnect the battery, start the engine and check for oil leaks.
- 13 Stop the engine and lower the ramp.
- 14 Allow sufficient time for the oil to drain back into the sump, check the oil level and top-up to the high mark on the dipstick with oil of a recommended make and grade.

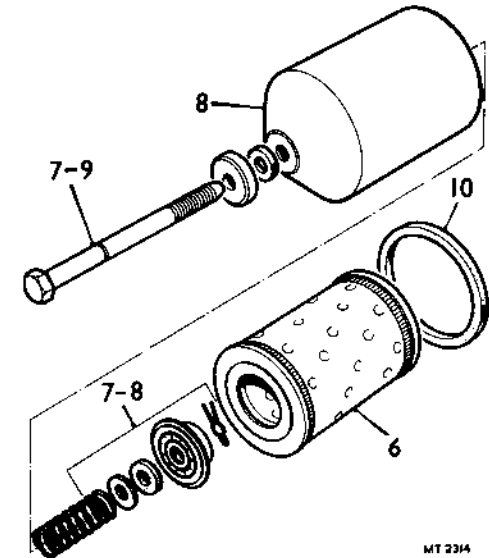
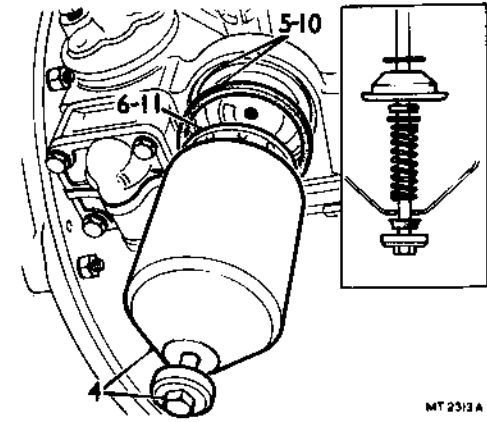

**OIL TRANSFER HOUSING**

Remove and refit 12.60.14

**Removing**

- 1 Disconnect the battery.
- 2 Disconnect the three Lucas leads from the oil pressure switch.
- 3 Remove the centre retaining bolt and withdraw the transfer housing.
- 4 Remove the 'O' ring seals from the housing.

**Refitting**

- 5 Clean the transfer housing and crankcase mating faces.
- 6 Using new 'O' ring seals fit the transfer housing engaging the dowel in the crankcase in the hole in the housing.
- 7 Fit and tighten the centre retaining bolt and plain washer.
- 8 Reconnect the three electrical leads to the correct connectors. 86.65.30.
- 9 Reconnect the battery.

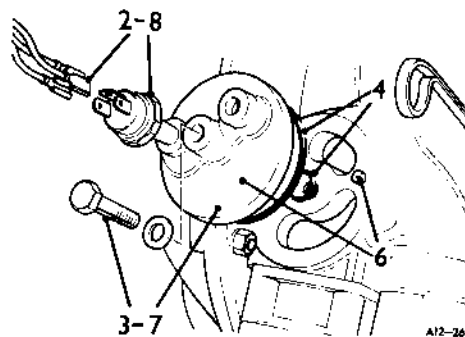
**OIL PICK-UP STRAINER**

Remove and refit 12.60.20

**Removing**

- 1 Remove the sump. 12.60.44.
- 2 Remove the two bolts and plain washers.
- 3 Withdraw the strainer.
- 4 Remove the gasket.

**Refitting**

- 5 Clean the strainer gauge.
- 6 Clean the strainer and crankcase mating faces.
- 7 Fit a new gasket.
- 8 Fit the strainer and secure with the two bolts and plain washers.
- 9 Refit the sump. 12.60.20.

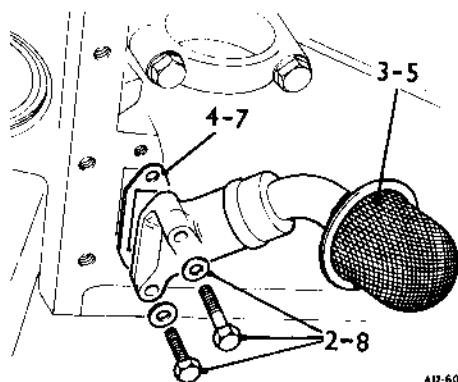
**OIL PUMP**

Remove and refit 12.60.26

**Removing**

- 1 Drive the car onto a ramp and disconnect the battery.
- 2 Raise the ramp.
- 3 Remove the two bolts securing the clutch slave cylinder to the bell housing.
- 4 Carefully withdraw the clutch slave cylinder, complete with fluid pipe.
- 5 Withdraw the slave cylinder completely and secure it in a convenient position to gain access to the oil pump.
- 6 Remove the bell housing nut and bolt.
- 7 Remove the four oil pump retaining bolts and spring washers.
- 8 Withdraw the pump complete with the hexagonal drive shaft.
- 9 Remove the 'O' sealing ring.

**Refitting**

- 10 Clean the oil pump and crankcase mating faces.
- 11 Fit a new 'O' ring to the groove in the oil pump.
- 12 Engage the hexagonal drive shaft in the oil pump rotor.
- 13 Fit the oil pump ensuring that the drive shaft engages with the distributor.
- 14 Fit and evenly tighten the four oil pump retaining bolts and spring washers to the correct torque - see 'TORQUE WRENCH SETTINGS'.
- 15 Fit the bell housing nut and bolt.
- 16 Fit the clutch slave cylinder ensuring that the push rod enters the hole in the rubber boot.
- 17 Tighten the two retaining bolts and spring washers.
- 18 Lower the ramp and reconnect the battery.
- 19 Run the engine for three minutes, raise the ramp and check for oil leaks.

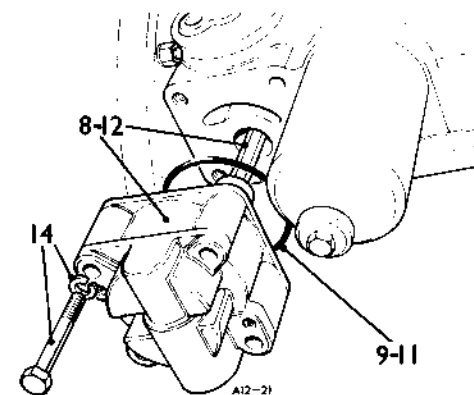
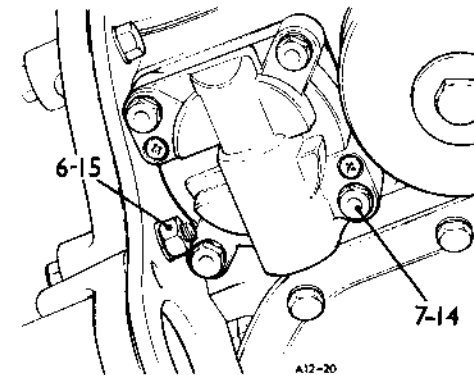

## OIL PUMP

### Overhaul

12.60.32

#### Dismantling

- 1 Remove the oil pump. 12.60.26.
- 2 Withdraw the hexagonal drive shaft.
- 3 Remove the two screws and lift off the pump cover from the pump body.
- 4 Remove the rotors.
- 5 Remove the 'O' sealing ring from the pump body.
- 6 Remove the split pin from the oil pump cover.
- 7 Remove the locating plug, spring and relief valve.
- 8 Remove the 'O' sealing ring from the locating plug.

#### Inspecting

- 9 Clean all components
- 10 Install the rotors in the pump body, ensuring that the chamfered edge of the outer rotor is at the driving end of the rotor pocket.
- 11 Check the end-float of the inner and outer ring.
- 12 Check the outer ring to pump body diametrical clearance.
- 13 Check the rotor lobe clearances.
- 14 Check the length of the relief valve spring.
- 15 Check the relief valve and its bore for scoring or damage.
- 16 Renew the pump assembly if the clearances or end-floats measured in operations 11 to 13 exceed the figures given in DATA.
- 17 Check the bush in the pump cover, renew if scored or worn.

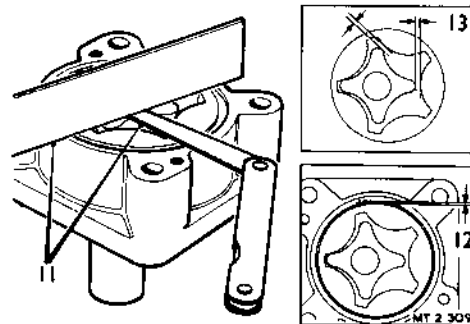
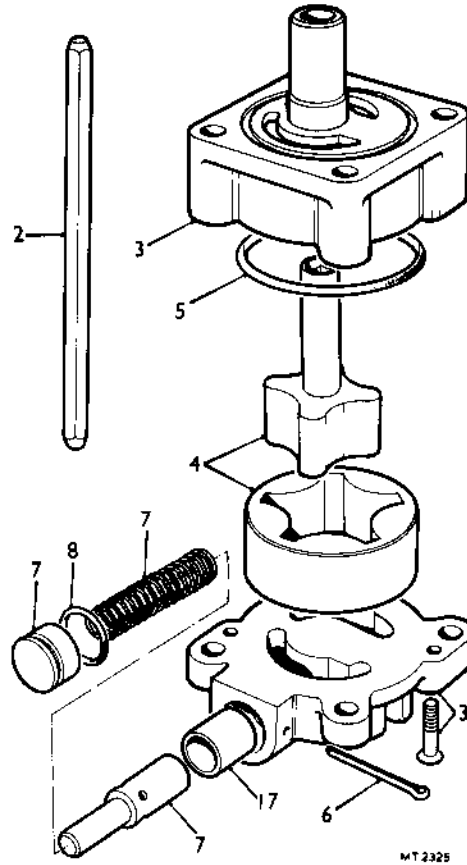

#### Reassembling

- 18 Lubricate all parts in clean engine oil before assembling.
- 19 Reverse the procedure in 1 to 8, noting:
  - a Fit the relief valve with its large diameter first, so that its small spigot will engage with spring.
  - b Fit a new 'O' sealing ring to the oil pressure relief valve locating plug.

- c Ensure that the outer rotor is installed in the pump body with its chamfered edge towards the driving end.
- d Fit a new 'O' sealing ring to the pump body.
- 20 Check the pump for freedom of action.
- 21 Fit the oil pump. 12.60.26.

#### DATA

##### Oil pump - Hobourn-Eaton

Outer ring end-float . . . . .	0.004 in (0.1 mm)
Inner ring end-float . . . . .	0.004 in (0.1 mm)
Outer ring to pump body diametrical clearance . . . . .	0.008 in (0.2 mm)
Rotor lobe clearance. . . . .	0.010 in (0.25 mm)

## OIL SUMP

### Remove and refit

12.60.44

#### Removing

- 1 Drive the car onto a ramp and disconnect the battery.
- 2 Remove the fresh-air duct.
- 3 Remove the fan guard.
- 4 Raise the ramp.
- 5 Drain the sump oil and refit the drain plug.
- 6 Remove the coupling plate bolts.
- 7 Remove the engine stabilizer. 12.45.16. (Where fitted).
- 8 Make up a support bracket from angle-iron in accordance with the dimensional drawing.

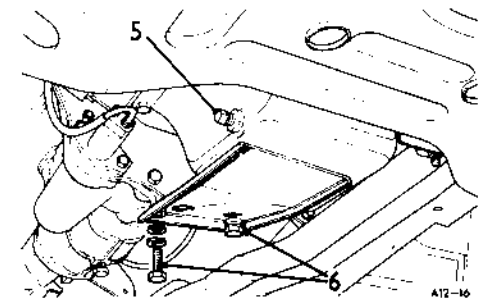

continued

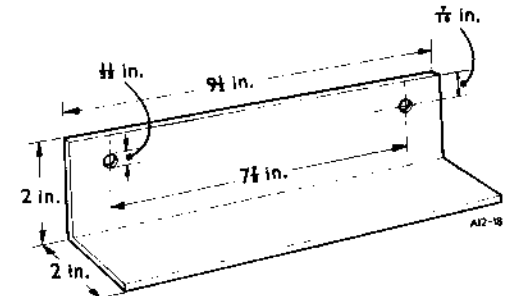

- 9 Remove the alternator support strap bolt and move the link away.
- 10 Remove the opposite timing cover lower bolt.
- 11 Using these bolts attach the support bracket to the timing cover.
- 12 Support the engine under the bracket with a jack.
- 13 Remove the two engine R.H. mounting bolts.
- 14 Remove the engine L.H. mounting to sub-frame nut.
- 15 Remove the sump nuts and bolts.
- 16 Raise the engine sufficiently to enable the sump complete with the L.H. engine mounting and cross-member to be withdrawn.

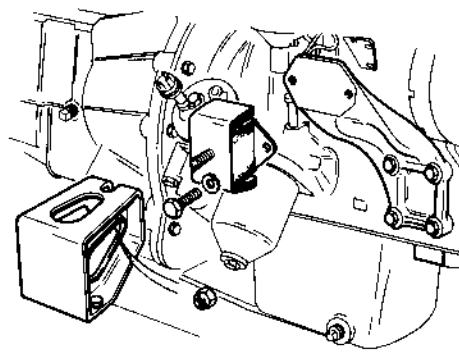

A12-98

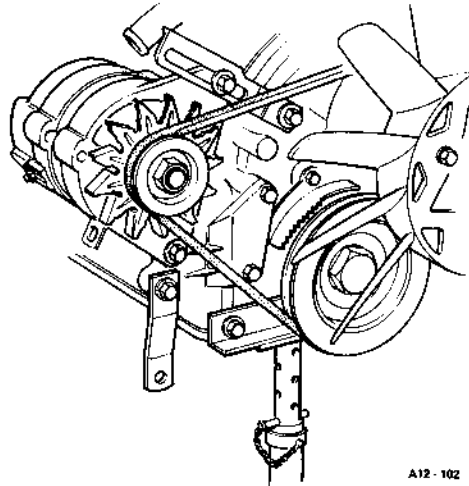

A12-102

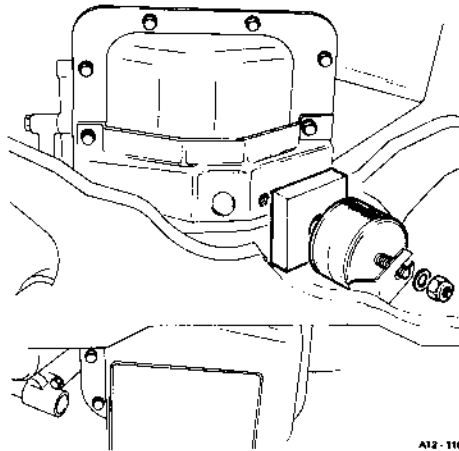

A12-110

### Refitting

- 17 Using a new gasket, manoeuvre the sump into position on the crankcase and loosely secure in position with a few bolts.
- 18 Fit the cross-member with mounting to the sump and fit and tighten the remaining sump retaining nuts and bolts.
- 19 Lower the engine and secure the L.H. rubber mounting to the sub-frame.
- 20 Connect the R.H. side engine mounting.
- 21 Fit the engine stabilizer. 12.45.16. (Where fitted).
- 22 Remove the jack, and the support bracket and refit the timing cover bolts and alternator strap.
- 23 Fit the coupling plate bolts.
- 24 Lower the ramp.
- 25 Fit the fan guard.
- 26 Fit the fresh air duct.
- 27 Fill the sump with engine oil of recommended make and grade to the high mark on the dipstick.
- 28 Reconnect the battery, run the engine and check for leaks.

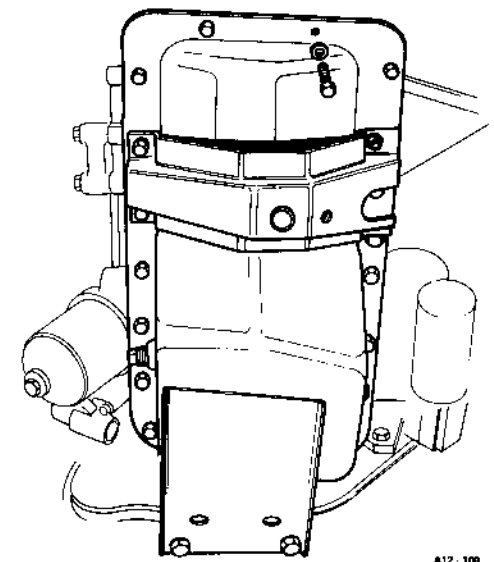

A12-108

## OIL PRESSURE RELIEF VALVE

Remove and refit 12.60.56

### Removing

- 1 Remove the oil pump. 12.60.26.
- 2 Withdraw the hexagonal drive shaft.
- 3 Remove the split pin from the oil pump casing.
- 4 Remove the locating plug, spring and plunger by tapping the pump cover.

**NOTE:** Since in some instances the 'O' ring on the locating plug may stick to the bore, in order to accomplish instruction 4 the pump cover will have to be removed and the plug tapped out from the underside of the cover. Follow instructions 5 and 6 if this is necessary.

- 5 Remove the two screws securing the pump cover to the main body and lift off the cover.
- 6 Using a suitable soft drip tap out of the plug from the underside of the pump cover.
- 7 Remove the 'O' ring from the locating plug.

### Examination

- 8 Examine the plunger and its bore for scores or wear.
- 9 Check the plunger spring length and renew if not in accordance with data.

### Refitting

- 10 Observing absolute cleanliness fit the plunger to the pump cover ensuring that it moves freely in its bore.
- 11 Fit the spring over the plunger spigot end noting that the close coiled end is inserted first.
- 12 Fit a new 'O' ring to the locating plug and insert the plug.
- 13 Fit a new split pin.
- 14 Fit the cover to the pump and secure with the two screws.
- 15 Fit the hexagonal shaft to the crankcase.
- 16 Refit the oil pump to the engine. 12.60.26.

### DATA

Relief valve spring free length . . .  
1.70 in (43,18 mm)

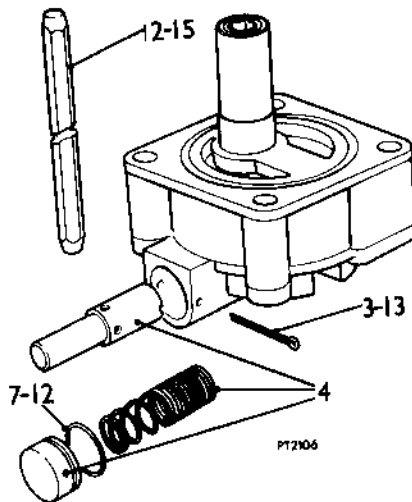

## TIMING CHAIN COVER — UK & Europe Specification

Remove and refit 12.65.01

### Removing

- 1 Remove the bonnet, drive the car on ramp and disconnect the battery.
- 2 Remove the crankshaft pulley. 12.21.02.
- 3 Remove the alternator. 86.10.02.
- 4 Remove the alternator mounting bracket. 12.25.21.
- 5 Remove the alternator adjusting link.
- 6 Remove the two front sump bolts and one each side.

- 7 Remove the fan and viscous coupling assembly. 26.25.21.
- 8 Remove the two bolts and nuts securing the timing cover to the cylinder head.
- 9 Remove the remaining timing cover retaining bolts, including the centre bolt.
- 10 Withdraw the timing cover and gaskets.
- 11 Place a piece of rag over the access to the sump to prevent items falling in by accident.

### Refitting

- 12 Remove the protective rags.
- 13 Clean the engine and timing cover mating faces and place new gaskets in position on the timing cover.
- 14 Locate the timing cover on the engine over the dowels and fit and tighten the centre retaining bolt, noting that it has a fibre washer under the head.
- 15 Fit the fan and viscous coupling unit.
- 16 Fit, but leave loose, the cylinder head to timing cover nuts and bolts.
- 17 Fit, but leave slack, the alternator adjusting link bracket.
- 18 Fit the alternator mounting bracket.
- 19 Fit the alternator but leave slack.
- 20 Connect the alternator harness plug to the alternator.
- 21 Loosely place in position the alternator drive belt.
- 22 Finally tighten the cylinder head to timing cover nuts and bolts.
- 23 Raise the ramp and fit and tighten the sump bolts.
- 24 Fit the crankshaft pulley.
- 25 Adjust the alternator drive belt tension. 86.10.05.
- 26 Secure the radiator with the two top brackets and four nuts.
- 27 Fit the fan guard.
- 28 Fit the bonnet.
- 29 Reconnect the battery.

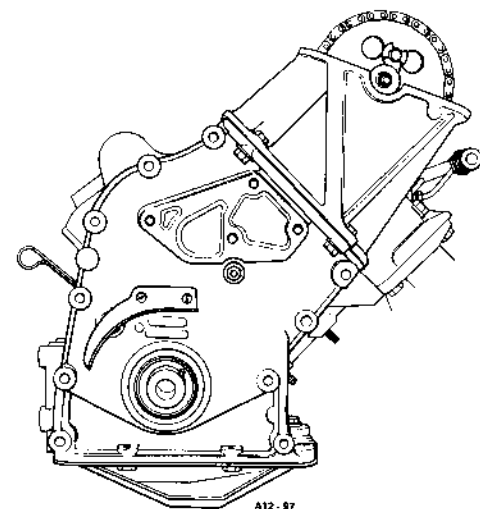
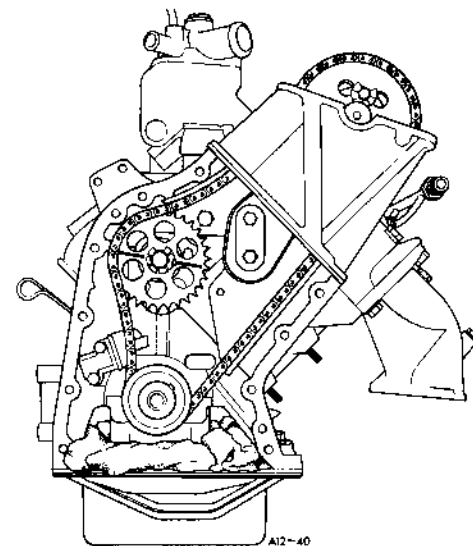

**TIMING CHAIN COVER –  
USA & Canada Specification**

Remove and refit 12.65.01

**Removing**

- 1 Remove the bonnet, drive car on ramp and disconnect the battery.
- 2 Remove the crankshaft pulleys. 12.21.02.
- 3 Remove the alternator. 86.10.02.
- 4 Remove the alternator mounting bracket. 12.25.21.
- 5 Remove the alternator adjusting link.
- 6 Remove the air pump. 17.25.07.
- 7 Remove the 'diverter and relief valve' complete with attachment bracket.
- 8 Remove the air pump bracket and lifting eye. 17.25.07.
- 9 Remove the compressor steady bracket.
- 10 Remove the two bolts and nuts securing the timing cover to the cylinder head.
- 11 Slacken the four bolts securing the compressor carrier bracket to the engine.

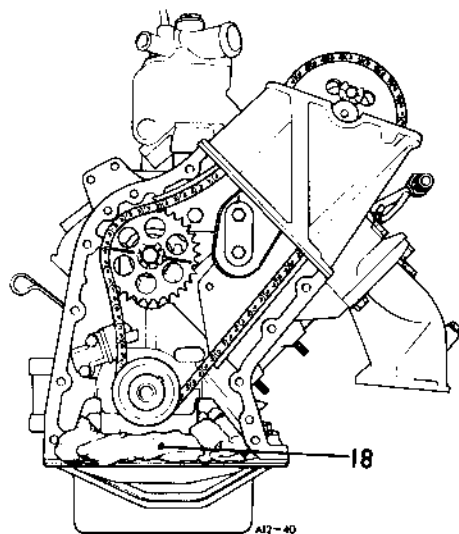
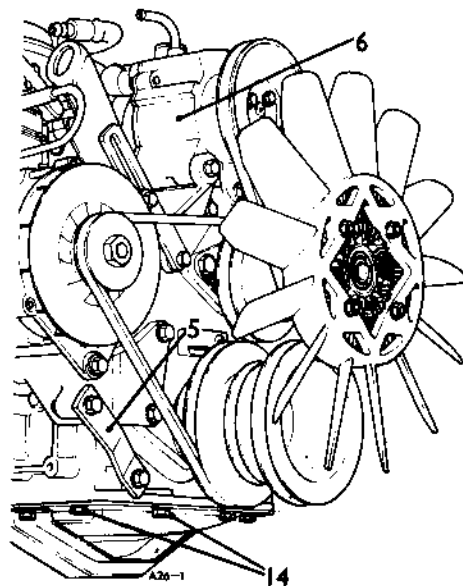

- 12 Remove the three compressor adjusting bolts.
- 13 Remove the compressor adjusting bracket.
- 14 Remove the two front sump bolts and one each side.
- 15 Remove the timing cover centre attachment bolt and bottom left hand bolt (looking at engine from front).
- 16 Remove the fan and torquatrol assembly – instructions 6 to 9. 26.25.21.
- 17 Withdraw the timing cover and gaskets.
- 18 Place a piece of rag over the access to the sump to prevent items falling in by accident.

**Refitting**

- 19 Remove the protective rags.
- 20 Clean the engine and timing cover mating faces and place new gaskets in position on the timing cover.
- 21 Locate the timing cover on the engine over the dowels and fit and tighten the centre retaining bolt, noting that it has a fibre washer under the head.
- 22 Fit the fan and torquatrol assembly securing it to the timing cover with the two uncommitted bolts.
- 23 Fit the air compressor adjustment bracket securing it with the rear bolt but leaving it slack.
- 24 Fit, but leave loose, the cylinder head to timing cover nuts and bolts.
- 25 Fit the air compressor steady bracket and tighten the bolts.
- 26 Tighten the air compressor adjustment bracket rear bolt.
- 27 Fit the air compressor to the adjustment bracket but leave the bolts slack.
- 28 Fit the air pump bracket together with the lifting hook.
- 29 Fit the diverter and relief valve bracket complete with valve.
- 30 Fit, but leave slack, the alternator adjusting link bracket.
- 31 Fit the alternator mounting bracket.
- 32 Fit the alternator but leave slack.
- 33 Connect the alternator harness plug – instructions 16 and 17. 86.10.02.
- 34 Fit the air pump, but leave slack.

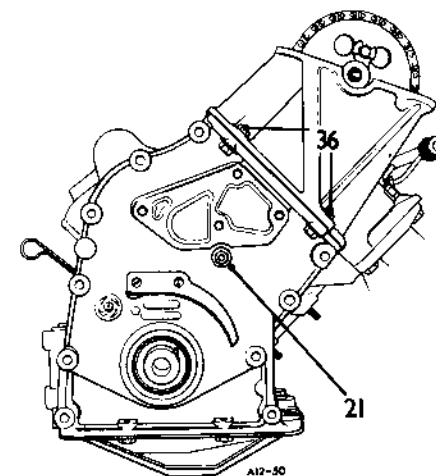
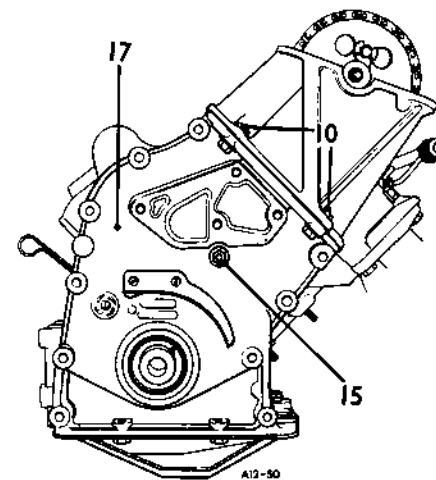

- 35 Loosely place in their correct relative positions the following:
  - a The alternator drive belt.
  - b The air pump drive belt.
  - c The air compressor drive belt.
- 36 Finally tighten the cylinder head to timing cover nuts and bolts.
- 37 Raise the ramp and fit and tighten the sump bolts.
- 38 Fit the crankshaft and auxiliary pulleys – instructions 9 to 11. 12.21.02.
- 39 Tighten the four compressor to carrier engine bolts.
- 40 Fit compressor drive belt to the pulleys and adjust tension. 82.10.01.
- 41 Adjust the alternator drive belt tension – 86.10.05.
- 42 Adjust air pump drive belt tension – 17.25.13.
- 43 Connect air pump hose to 'diverter and relief valve'.
- 44 Fit the fan blades to the torquatrol unit.
- 45 Secure the radiator with the two top brackets and four nuts.
- 46 Fit the fan guard.
- 47 Fit the bonnet.
- 48 Reconnect the battery.

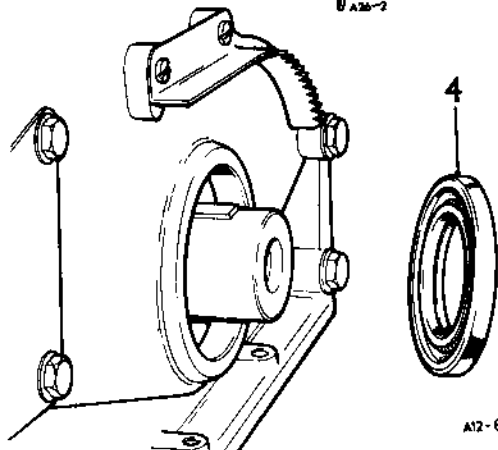
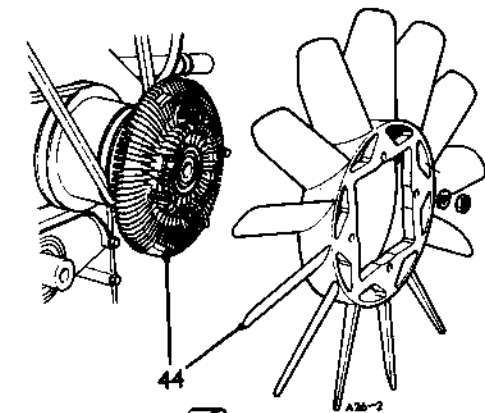

USA Specification

### TIMING COVER OIL SEAL

Remove and refit 12.65.05

#### Removing

- 1 Disconnect the battery.
- 2 Remove the crankshaft pulleys. 12.21.02.
- 3 Lever out the old seal.

#### Refitting

- 4 Dip a new seal in engine oil and with the lip face leading tap it squarely into its housing until flush with the outside of the timing cover. Check by placing a straight edge across the face of the seal and timing cover.
- 5 Refit the crankshaft pulleys. 12.21.07.
- 6 Reconnect the battery.

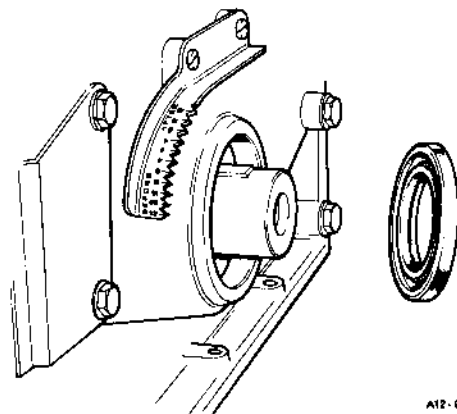

### VALVE TIMING – UK and Europe Specification

Check and adjust 12.65.08

#### Checking

- 1 Disconnect the battery.
- 2 Turn the engine over until the timing mark on the crankshaft pulley coincides with the zero mark on the timing cover scale.
- 3 Remove the fresh air duct. 80.15.31.
- 4 Remove the distributor cap and check that the rotor arm points to the rear bolt securing the inlet manifold to the cylinder head.
- 5 Remove the camshaft cover. 12.29.42.
- 6 The valve timing is correct when the timing mark on the camshaft flange is in line with the corresponding groove in the camshaft front bearing cap.
- 7 Refit the distributor cap.
- 8 Refit the camshaft cover. 12.29.42.
- 9 Refit the fresh air duct. 80.15.31.
- 10 Reconnect the battery.

*continued*

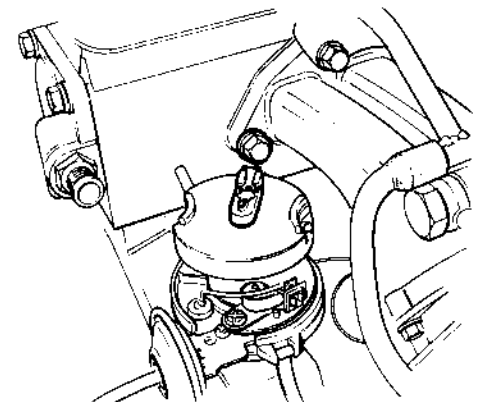
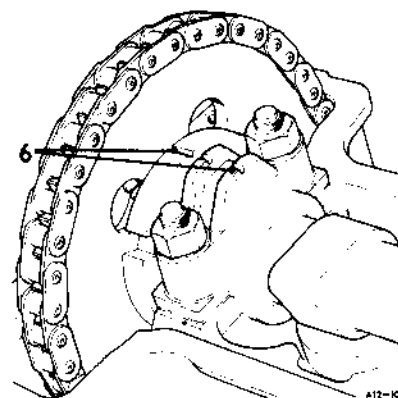
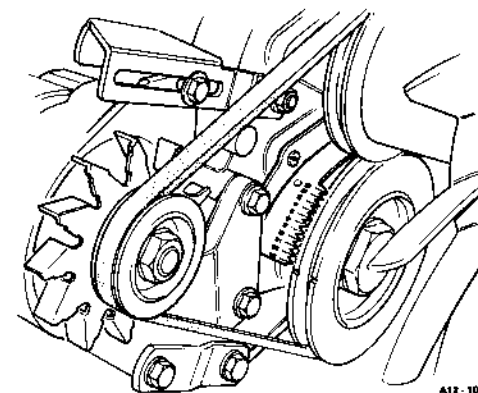

UK and Europe Specification



**Adjusting**

- 11 Disconnect the battery.
- 12 Remove the fresh air duct. 80.15.31.
- 13 Remove the timing chain cover. 12.65.01.
- 14 Remove the distributor cap.
- 15 Remove the camshaft cover.
- 16 Turn the engine over so that the timing mark on the camshaft flange is in line with the groove in the camshaft front bearing cap, i.e. number 1 cylinder T.D.C. firing - instruction 6.
- 17 Check that the distributor rotor arm points to the rear bolt securing the inlet manifold - instruction 4.
- 18 Remove the hydraulic timing chain tensioner. 12.65.28 instructions 2 to 4.
- 19 Fit a 'slave' bolt to the timing cover centre hole in the cylinder block to ensure alignment when refitting the cover.
- 20 Remove the two bolts securing the adjustable chain guide.
- 21 Slacken the remaining guide bolt.
- 22 Remove the adjustable guide.
- 23 Slip the timing chain from the jackshaft and crankshaft sprockets.
- 24 Temporarily fit the timing chain cover locating it on the two dowels.
- 25 Temporarily fit the crankshaft pulley.
- 26 Turn the crankshaft until the timing mark on the crankshaft pulley coincides with the zero figure on the timing cover scale - instruction 2.
- 27 Remove the timing cover and pulley.
- 28 Fit the timing chain to the sprockets keeping it taut on the drive side, i.e. the run between the camshaft and the crankshaft sprockets.
- 29 Since the jackshaft sprocket may have been moved, whilst disconnecting the chain, re-set to its correct position by turning the sprocket until the scribed line is equidistant between bolts A and B and the distributor rotor arm points to the rear bolt head securing the inlet manifold to the cylinder head.
- 30 Fit the adjustable guide locating it loosely with the two bolts - noting that the locking bolt has a plain and spring washer.

- 31 Fit the hydraulic timing chain tensioner. 12.65.28 instructions 12 to 20.
- 32 Remove the 'slave' bolt.
- 33 Refit the timing chain cover. 12.65.01.

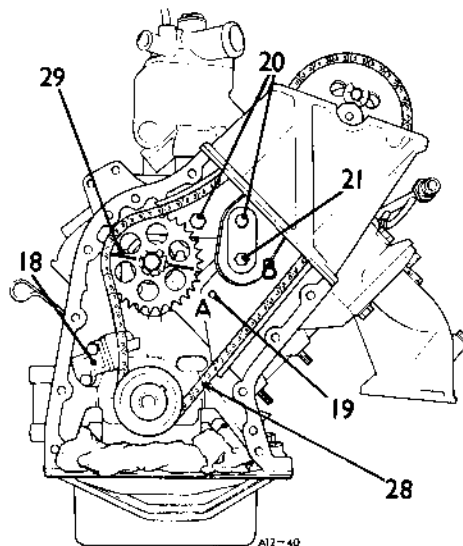
**DATA****Valve timing**

Inlet valves open . . . . .	16°	B.T.D.C.
Inlet valves close . . . . .	56°	A.B.D.C.
Exhaust valves open . . . . .	56°	B.B.D.C.
Exhaust valves close . . . . .	16°	A.T.D.C.

**VALVE TIMING -  
USA & Canada Specification**

Check and adjust 12.65.08

**Checking**

- 1 Disconnect the battery.
- 2 Turn the engine over until the timing mark on the crankshaft pulley coincides with the zero mark on the timing cover scale.
- 3 Remove the fresh air duct. 80.15.31.
- 4 Remove the distributor cap and check that the rotor arm points to the rear bolt securing the inlet manifold to the cylinder head.
- 5 Remove the camshaft cover. 12.29.42.
- 6 The valve timing is correct when the timing mark on the camshaft flange is in line with the corresponding groove in the camshaft front bearing cap.
- 7 Refit the distributor cap.
- 8 Refit the camshaft cover. 12.29.42.
- 9 Refit the fresh air duct. 80.15.31.
- 10 Reconnect the battery.

**Adjusting**

- 11 Disconnect the battery.
- 12 Remove the fresh air duct. 80.15.31.
- 13 Remove the timing chain cover. 12.65.01.
- 14 Remove the distributor cap.
- 15 Remove the camshaft cover.
- 16 Turn the engine over so that the timing mark on the camshaft flange is in line with the groove in the camshaft front bearing cap, i.e. number 1 cylinder T.D.C. firing - instruction 6.
- 17 Check that the distributor rotor arm points to the rear bolt securing the inlet manifold - instruction 4.
- 18 Remove the hydraulic timing chain tensioner. 12.65.28 instructions 2 to 4.
- 19 Fit a 'slave' bolt to the timing cover centre hole in the cylinder block to ensure alignment when refitting the cover.
- 20 Remove the two bolts securing the adjustable chain guide.
- 21 Slacken the remaining guide bolt.
- 22 Remove the adjustable guide.
- 23 Slip the timing chain from the jackshaft and crankshaft sprockets.

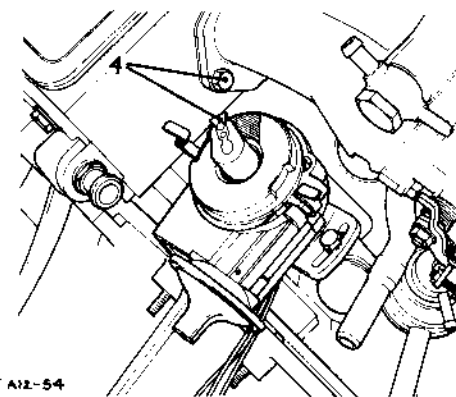
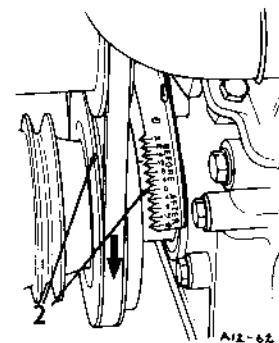

**USA & Canada  
Specification**

- 24 Temporarily fit the timing chain cover locating it on the two dowels.
- 25 Temporarily fit the crankshaft pulley.
- 26 Turn the crankshaft until the timing mark on the crankshaft pulley coincides with the zero figure on the timing cover scale – instruction 2.
- 27 Remove the timing cover and pulley.
- 28 Fit the timing chain to the sprockets keeping it taut on the drive side, i.e. the run between the camshaft and crankshaft sprockets.
- 29 Since the jackshaft sprocket may have been moved, whilst disconnecting the chain, re-set to its correct position by turning the sprocket until the scribed line is equidistant between the bolts A and B and the distributor rotor arm points to the rear bolt head securing the inlet manifold to the cylinder head.
- 30 Fit the adjustable guide locating it loosely with the two bolts – noting that the locking bolt has a plain and spring washer.
- 31 Fit the hydraulic timing chain tensioner 12.65.28 instructions 12 to 20.
- 32 Remove the 'slave' bolt.
- 33 Refit the timing chain cover 12.65.01 instructions 19 to 48.

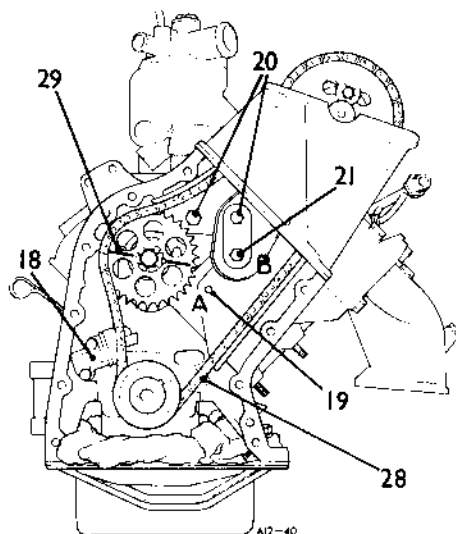
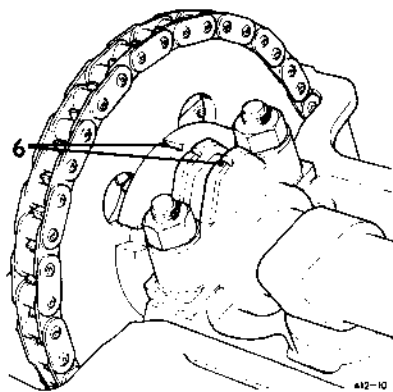

## TIMING CHAIN AND SPROCKETS

Remove and refit 12.65.12

### Removing

- 1 Remove the timing chain. 12.65.14.
- 2 Unlock and remove the jackshaft retaining bolt.
- 3 Withdraw the jackshaft sprocket.
- 4 Remove the oil thrower.
- 5 Remove the crankshaft sprocket.
- 6 Remove the crankshaft key.
- 7 Remove the sprocket alignment shims.
- 8 Detach the camshaft sprocket from the support bracket.

### Refitting

- 9 Using a new locking washer, fit the jackshaft sprocket, ensuring that it locates correctly over the dowel.
- 10 Fit and tighten the retaining bolt to the correct torque, see '**TORQUE WRENCH SETTINGS**', and lock it.
- 11 Temporarily fit the crankshaft sprocket and check its alignment with the jackshaft sprocket by using a straight edge across the two sprockets as illustrated.
- 12 Adjust any misalignment by the addition of shims behind the crankshaft sprocket.
- 13 Remove the crankshaft sprocket, fit the crankshaft key and refit the sprocket.
- 14 Fit the oil thrower noting that the dished side faces outwards away from the engine.
- 15 Attach the camshaft sprocket to the support bracket with a 'slave' nut.
- 16 Refit the timing chain. 12.65.14.

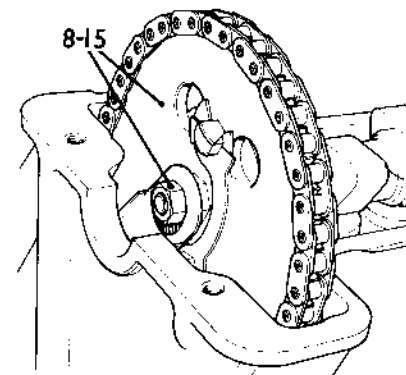
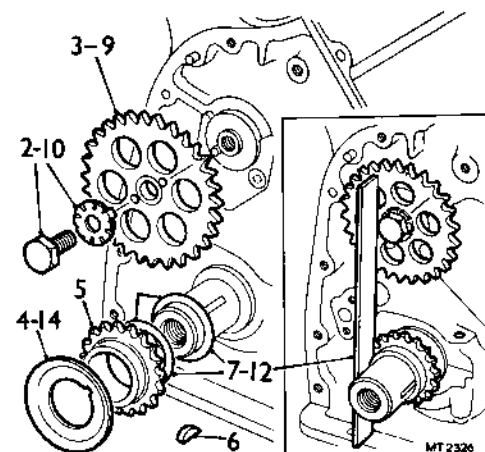

### DATA

#### Valve timing

Inlet valves open	16°	B.T.D.C.
Inlet valves close	56°	A.B.D.C.
Exhaust valves open	56°	B.B.D.C.
Exhaust valves close	16°	A.T.D.C.

Remove and refit

12.65.14

## Removing

- 1 Remove the timing chain cover. 15.65.01.
- 2 Remove the camshaft cover.
- 3 Remove the distributor cap.
- 4 Turn the engine over so that the timing mark on the camshaft is at the bottom i.e. 180° distant from the groove in the camshaft front bearing cap, to enable instruction 5 to be carried out.
- 5 Unlock and remove the exposed camshaft retaining bolt.
- 6 Turn the engine over until the mark on the camshaft flange is in line with the groove on the camshaft front bearing cap.
- 7 Check that the distributor rotor arm points to the head of the rear bolt securing the inlet manifold i.e. T.D.C. number 1 cylinder firing.
- 8 Secure the camshaft sprocket to the support bracket with a 'slave' nut.
- 9 Unlock and remove the remaining bolt retaining the camshaft sprocket.
- 10 Remove the hydraulic timing chain tensioner and guide plate.

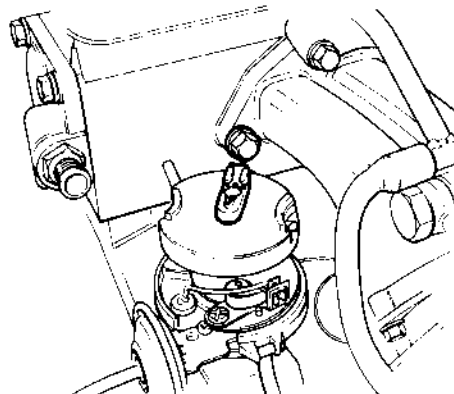
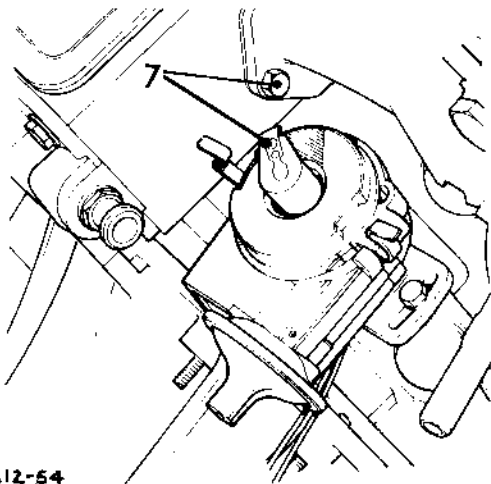
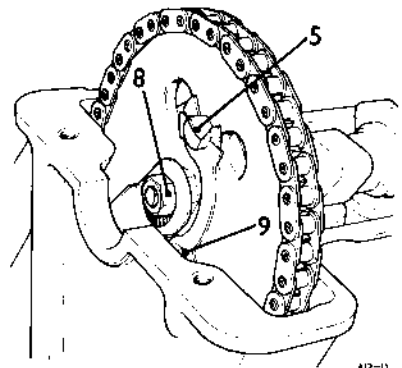
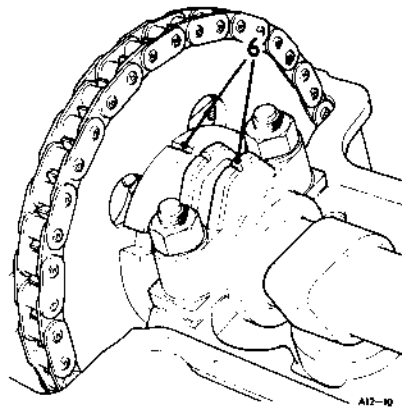

UK &amp; Europe Specification

- 11 Remove the locking bolt from the adjustable chain guide.
- 12 Remove the common bolt securing the adjustable guide and camshaft sprocket support bracket.
- 13 Remove the adjustable guide.
- 14 Remove the bolt securing the camshaft support bracket and fixed guide whilst holding the camshaft sprocket.
- 15 Remove the fixed guide and release the chain from the jackshaft and camshaft sprockets and withdraw upwards the camshaft sprocket and bracket together with the timing chain.

## Refitting

- 16 Encircle the camshaft sprocket with the timing chain and insert it through the aperture with the support bracket and pass the chain over the jackshaft and crankshaft sprockets.
- 17 Fit the fixed guide and support bracket and loosely secure with the common bolt and spring washer.
- 18 Fit the adjustable guide and loosely secure with the two bolts noting that the locking bolt has a plain and spring washer.
- 19 Fit a slave bolt to the timing cover centre retaining bolt hole.
- 20 Secure the camshaft sprocket to the camshaft with one bolt and a new tab washer.
- 21 Turn the jackshaft sprocket so that the scribed line across it is equidistant between the 'slave' bolt A and bolt 'B'.
- 22 Check that the distributor arm is in the position as described in instruction 7.

**NOTE:** If it is suspected that the crankshaft may have been turned, temporarily fit the timing cover and crankshaft pulley and check that the timing mark on the pulley coincides with the zero figure on the timing cover scale.

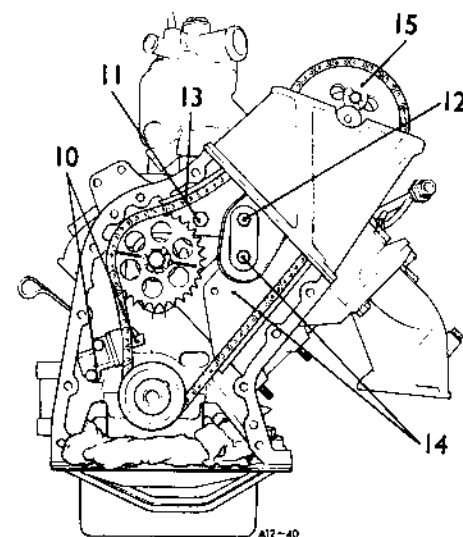

- 23 Fit the hydraulic timing chain tensioner 12.65.28 reversing instructions 2 to 4 ensuring that the three retaining bolts for the chain guides are tightened and that the position of the jackshaft sprocket has not altered.

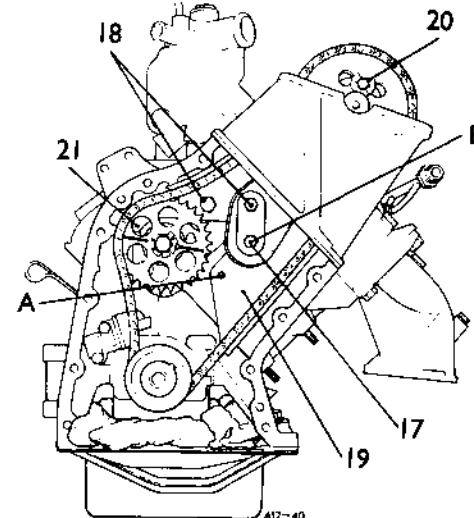
*continued*

USA &amp; Canada Specification

- 24 Remove the 'slave' nut supporting the camshaft sprocket and ensure that the threaded spigot does not foul in the support bracket hole.
- 25 Turn the engine over sufficiently to enable the remaining camshaft sprocket retaining bolt to be fitted.
- 26 Tighten and lock the bolt and turn the engine back again and finally tighten and lock the first bolt.
- 27 Fit the camshaft cover.
- 28 Fit the distributor cap.
- 29 Fit the timing chain cover. 19.65.01.

## TIMING CHAIN SPROCKETS

Remove and refit 12.65.22

This operation is covered under operation 12.65.12.

## TIMING CHAIN TENSIONER

Remove and refit 12.65.28

### Removing

- 1 Remove the timing chain cover. 12.65.01.
- 2 Remove the tensioner retaining bolts.
- 3 Remove the tensioner from the engine.
- 4 Remove the backplate between the tensioner body and cylinder block.

### Dismantling

- 5 Press-in the slipper and remove it from the tensioner body.
- 6 Remove the ratchet and spring.

### Examination

- 7 Check the slipper pad for wear and renew if necessary.
- 8 Renew the ratchet if worn.
- 9 Check the spring and renew if it is not in accordance with DATA.
- 10 Examine the tensioner body and check that the oil inlet hole is clear.
- 11 Ensure that the oil outlet hole is clear.

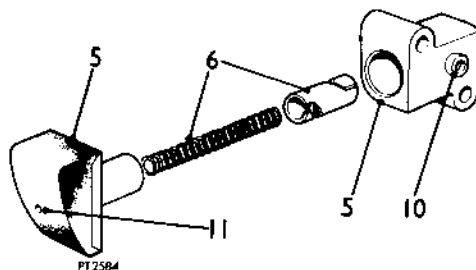
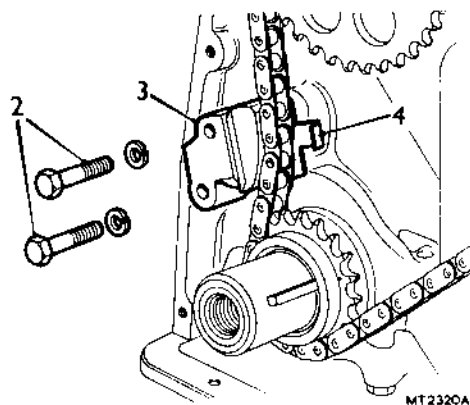

### Reassembling

- 12 Insert the slipper into the bore.
- 13 Fit the ratchet into the bore and turn clockwise with an Allen key to lock it in a retracted position.

**NOTE:** To prevent the tensioner releasing while fitting, insert a spacer between the tensioner body and the back of the slipper.

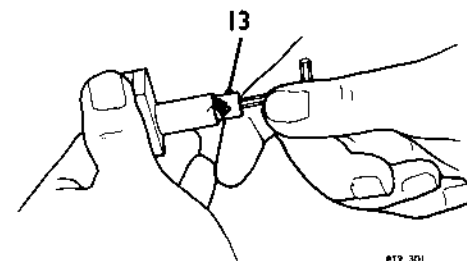

### Refitting

- 14 Fit the tensioner assembly and back plate to the cylinder block taking care not to allow the tensioner to release. Secure with the two bolts and spring washers. Remove the spacer.
- 15 Insert a 0.100 in (2.54 mm) feeler or slip gauge between the slipper and tensioner body - dimension A.
- 16 Slacken the three chain guide retaining bolts.
- 17 Press down, in the direction of the arrow, on top of the adjustable chain guide until the feeler or slip gauge is a sliding fit.
- 18 Whilst holding the guide in this position tighten the adjustable guide bolt first, and then the two remaining bolts.
- 19 Remove the feeler or slip gauge.
- 20 Remove the camshaft cover and check that the camshaft spigot is positioned centrally in the support bracket and does not foul when the camshaft is revolved.
- 21 Refit the timing chain cover. 12.65.01.

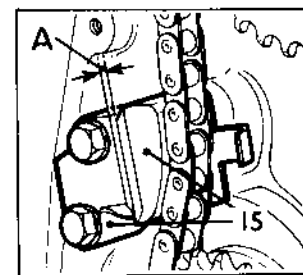
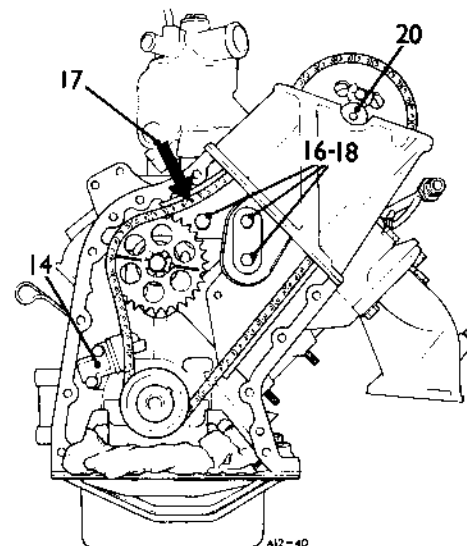

### DATA

Tensioner spring free length . . . . . 2.750 in (69,8 mm)

P12 301

A12-40

MT2320A

PT2584

## TIMING CHAIN GUIDES

Remove and refit

12.65.50

## Removing

- 1 Remove the timing chain cover, 12.65.01.
- 2 Remove the fresh air duct, 80.15.31.
- 3 Remove the camshaft cover.
- 4 Remove the distributor cap.
- 5 Turn the engine over until the following conditions are achieved:
  - a The timing mark on the camshaft flange is in line with the groove in the camshaft front bearing cap.
  - b The scribed line across the jackshaft sprocket is equal distance between bolt A and hole B.
  - c The distributor rotor arm points to the head of the rear bolt securing the inlet manifold to the cylinder head.

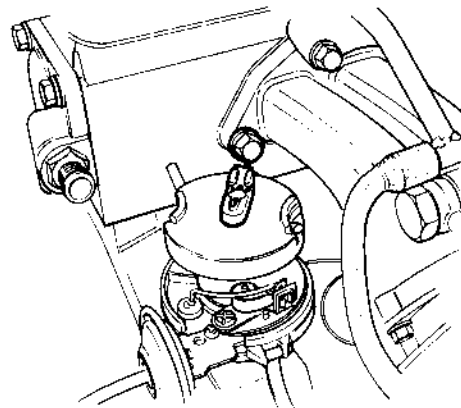

A12-33

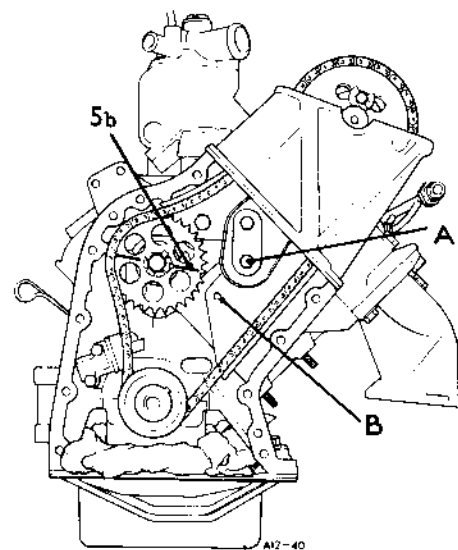

A12-40

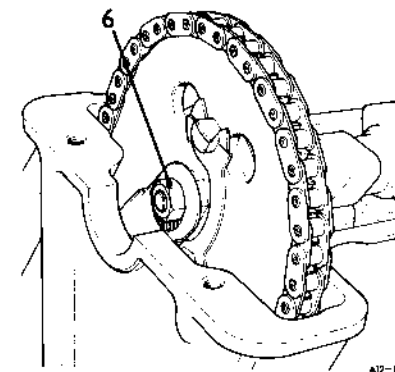

A12-11

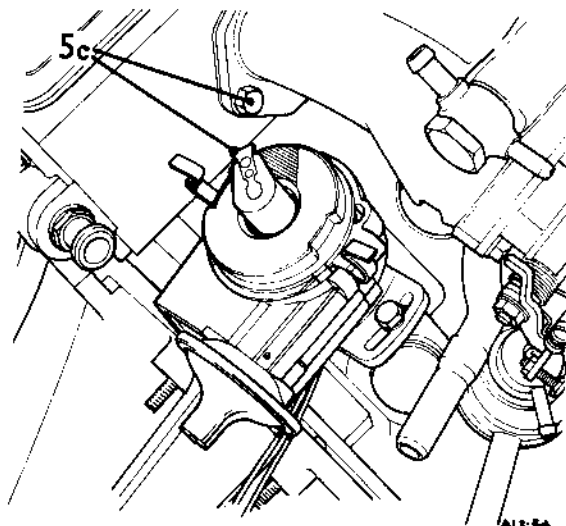

A12-34

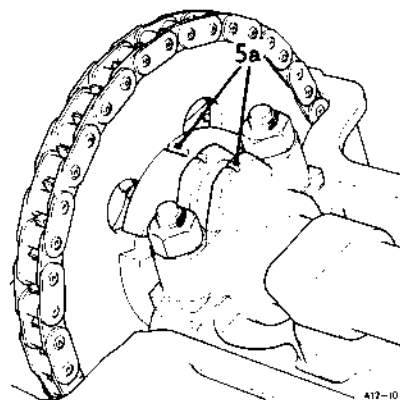

A12-10

USA &amp; Canada Specification

UK &amp; Europe Specification

- 6 Secure the camshaft sprocket to the support bracket with a 'slave' nut.
- 7 Insert a 0.100 slip gauge between the body of the hydraulic tensioner and the back of the slipper to prevent the tensioner releasing when the chain pressure is released, and remove the tensioner.
- 8 Remove the three chain guide retaining bolts and withdraw:
  - a The adjustable guide.
  - b The fixed guide.

## Refitting

- 9 Fit the fixed guide and support bracket securing it loosely with the common bolt.
- 10 Fit a 'slave' bolt to the timing cover centre retaining bolt to facilitate refitting the cover.
- 11 Fit the adjustable guide retaining it loosely with the two bolts, noting that the locking bolt has a plain and spring washer.
- 12 Fit the timing chain tensioner.
- 13 Insert a 0.100 in feeler gauge between the body of the tensioner and the back of the slipper.

- 14 Press downwards on the adjustable guide whilst tightening the locking bolt.
- 15 Tighten the two remaining bolts.
- 16 Remove the 'slave' bolt.
- 17 Remove the 'slave' nut and ensure that the threaded spigot does not foul in the support bracket hole.
- 18 Check that the position of the jackshaft sprocket has not altered as described in instruction 5b.
- 19 Refit the timing chain cover — 12.65.01 — instructions 19 to 48.
- 20 Refit the camshaft cover.
- 21 Refit the distributor cap.

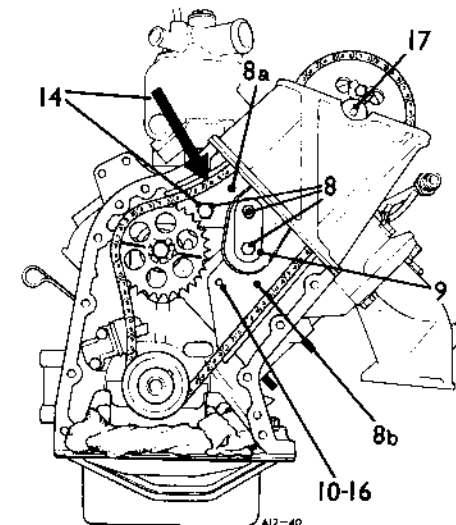

A12-40

## JACKSHAFT

### Remove and refit

12.10.14

#### Removing

- 1 Disconnect the battery.
- 2 Remove the fresh air duct, see 80.15.31.
- 3 Remove the radiator, see 26.40.01.
- 4 Remove the air conditioning condenser, see 82.15.10 (if fitted).
- 5 Remove the timing cover, see 12.65.01.
- 6 Remove the inlet manifold complete with carburetters, see 19.15.15.
- 7 Remove the water pump cover, see 26.50.01.
- 8 Remove the impeller, see 26.50.01.
- 9 Remove the petrol pump, see 19.48.08.
- 10 Remove the camshaft cover, see 12.29.42.
- 11 Turn the engine over so that the timing mark on the camshaft flange is in line with the groove on the camshaft front bearing cap.
- 12 Remove the distributor cap.
- 13 Remove the distributor, see 86.35.20.
- 14 Remove the hydraulic timing chain tensioner, see 12.65.28.
- 15 Remove the two bolts securing the adjustable chain guide and remove the guide.
- 16 Lift the chain from the jackshaft sprocket and turn the sprocket to gain access through the holes to the two Allen screws securing the jackshaft keeper plate to the cylinder block.
- 17 Remove the screws and withdraw the keeper plate.
- 18 Hold the timing chain clear of the sprocket and withdraw the jackshaft complete with the sprocket.
- 19 Secure the jackshaft in a vice and unlock and remove the sprocket retaining bolt and withdraw the sprocket.

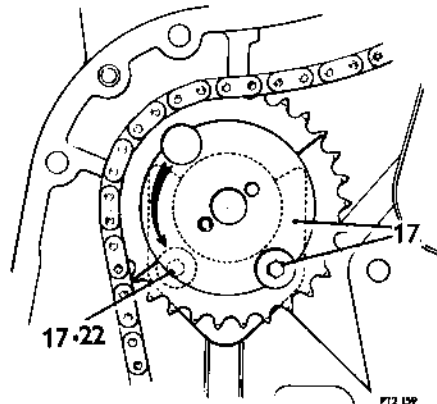
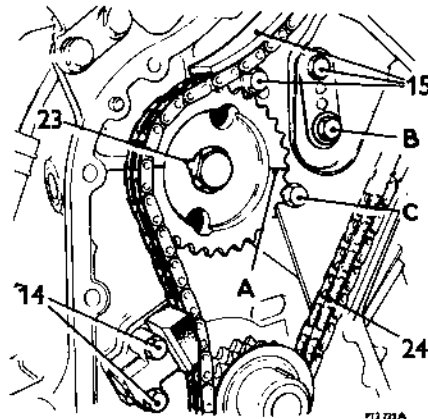
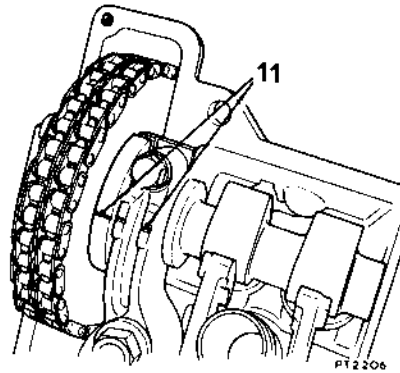

#### Refitting

- 20 Hold the jackshaft in a vice and fit the sprocket to the shaft, locating it on the single dowel. Secure the sprocket with the lock washer and bolt.
- 21 Fit the jackshaft into the cylinder block and lift the chain to engage the sprocket.
- 22 Fit the jackshaft keeper plate and secure in position with the two Allen screws.
- 23 While holding the chain clear of the sprocket, turn the jackshaft until the scribed line 'A' is equidistant between bolts 'B' and 'C' with the dowel to the left (looking at the engine from the front).
- 24 Check that the timing chain is taut on the drive side — i.e. the run between the camshaft and crankshaft sprocket — and fit the hydraulic tensioner, see 12.65.28, instructions 11 to 19, omitting instruction 16.
- 25 Fit the petrol pump, ensuring that the lever rides on top of the jackshaft cam.
- 26 Fit the water pump impeller and cover, see 26.50.01, instructions 9 to 14.
- 27 Fit the distributor and check the timing, see 86.35.15.
- 28 Fit the timing chain cover, see 12.65.01.
- 29 Fit the camshaft cover.
- 30 Fit the air conditioning condenser 82.15.10 (if fitted).
- 31 Fit the radiator, see 26.40.01.
- 32 Fit the inlet manifold complete with carburetters, see 19.15.15.
- 33 Fit the fresh air duct, see 80.15.31.
- 34 Check that the cooling system has been filled and connect the battery.

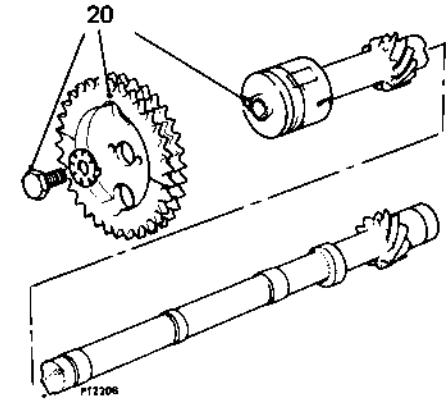

## CAMSHAFT

Remove and refit

12.13.02

## Removing

- 1 Disconnect the battery, and drain the coolant including the block.
- 2 Remove the rocker cover, see 12.29.42.
- 3 Turn the engine over so that the timing mark on the camshaft flange is 180° distant from the groove on the camshaft front bearing cap.
- 4 Remove the semi-circular grommet from the cylinder head.
- 5 Using a 'slave' nut, firmly secure the camshaft sprocket to the chain wheel support bracket.
- 6 Unlock and remove one camshaft sprocket retaining bolt.
- 7 Turn the engine until the timing mark on the camshaft flange is in line with the groove on the camshaft front bearing cap, i.e. No. 1 piston T.D.C. firing and the crankshaft pulley timing mark coinciding with the zero on the timing cover scale. Remove the distributor cap and check that the rotor arm points to the segment in the cap for No. 1 cylinder. Refit the cap.
- 8 Unlock and remove the remaining bolt retaining the camshaft sprocket.
- 9 Remove the rocker shaft assembly, see 12.29.54.
- 10 Withdraw the camshaft from the cylinder head.

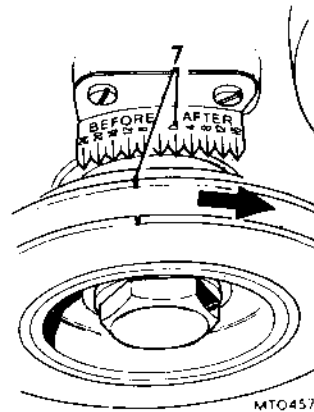
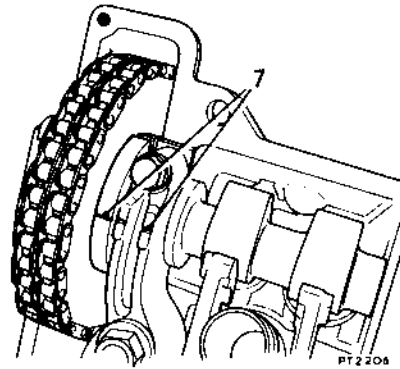
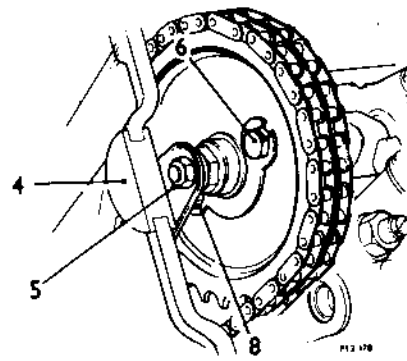

## Refitting

- 11 Turn the crankshaft back 90° from T.D.C. to prevent the valves touching the pistons whilst fitting the camshaft and carrying out instruction 14.
- 12 Fit the camshaft to the cylinder head.
- 13 Fit the rocker shaft assembly, see 12.29.54.
- 14 Check, and if necessary adjust, the valve clearances, see 12.29.48.
- 15 Turn the engine back to T.D.C. to the condition in instruction 7.
- 16 Turn the camshaft so that the timing mark on the flange is in line with the groove on the camshaft front bearing cap, i.e. No. 1 piston T.D.C. firing as in instruction 7.
- 17 Locate the sprocket on the camshaft flange, fit a new lock washer and secure with the retaining bolt. Tighten the bolt to a torque of 10 lbf ft (1.4 kgf m) and bend a locking tab into position against the bolt head. **Do not** hammer the locking tabs as this could lead to loss of bolt torque.
- 18 Turn the engine (using the crankshaft) to enable the remaining camshaft sprocket retaining bolt to be fitted, torqued and locked.
- 19 Remove the 'slave' nut securing the sprocket to the support bracket.
- 20 Fit the semi-circular grommet to the cylinder head.
- 21 Fit the rocker cover, see 12.29.42.
- 22 Reconnect the battery.
- 23 Refill the cooling system.

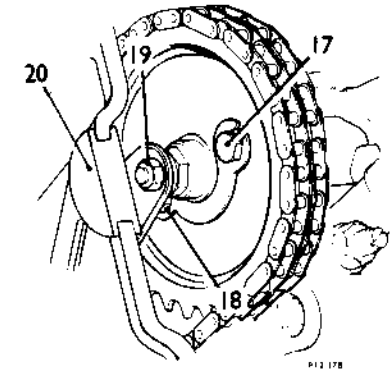
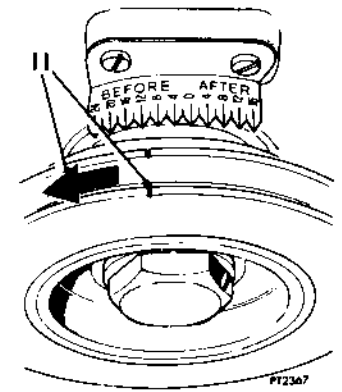

## CONNECTING RODS AND PISTONS

Remove and refit

12.17.01

Service tool: 38 U3 — piston ring compressor.

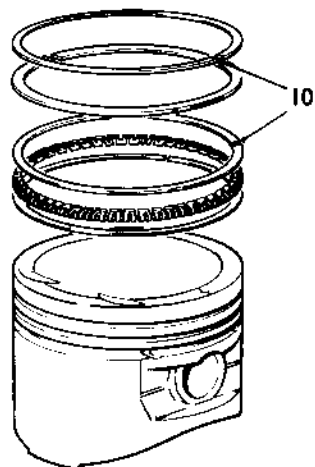
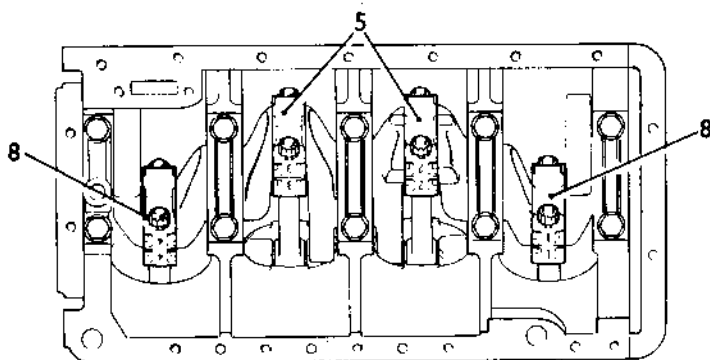
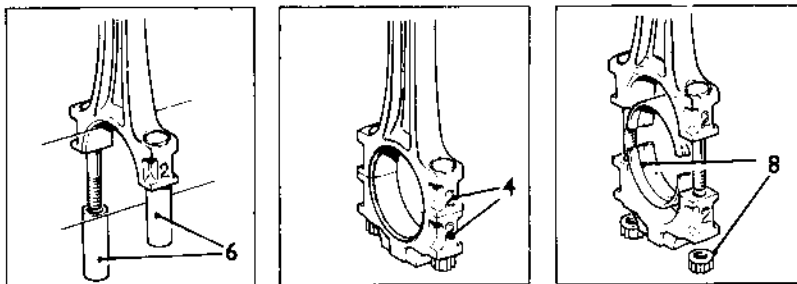

**CAUTION:** Do not mix any components during this operation.

### Removing

- 1 Isolate the battery.
- 2 Remove the cylinder head, see 12.29.10.
- 3 Remove the sump, see 12.60.44.
- 4 Check the identification numbers on the connecting rods and caps.
- 5 Turn the crankshaft to bring Nos. 1 and 4 pistons to T.D.C. and remove the nuts of Nos. 2 and 3 connecting rods.
- 6 Withdraw the bearing caps and lower shells and fit plastic or rubber sleeves over the connecting rod bolts to prevent damage to the crankpins.

- 7 Push the piston and connecting rod assemblies upwards and withdraw through the top of the bores and remove the upper shells.
- 8 Turn the crankshaft to bring Nos. 1 and 4 connecting rod bolts to an accessible position and remove the nuts and withdraw the bearing caps and lower shells.
- 9 Push the piston and connecting rod assemblies upwards and withdraw as instruction 7.

### Refitting

- 10 Stagger the piston ring gaps.
- 11 Lubricate the pistons and rings and compress the rings with service tool No. 38 U3.
- 12 Insert the connecting rod and piston assemblies into their respective bores ensuring that the arrow on top of the piston crown is pointing towards the front of the engine and the valve indents towards the right-hand side of the engine (as from the driver's position).
- 13 Fit the upper bearing shells to the connecting rods, ensuring that the keeper tags locate correctly in the connecting rod recesses.
- 14 Fit the lower bearing shells to the caps, ensuring that the keeper tags locate in the recesses.
- 15 Pull the connecting rods on to the crankpins and fit the bearing caps to their respective connecting rods, making sure that the identification numbers coincide and are adjacent. Note also that the bearing keeper recesses in the connecting rods and the caps are on the same side.
- 16 Secure the bearing caps with NEW nuts and tighten evenly to the correct torque, see 'TORQUE WRENCH SETTINGS'.
- 17 Fit the oil pick-up strainer.
- 18 Fit the sump, see 12.60.44.
- 19 Fit the cylinder head, using a new gasket.
- 20 Refill the sump with the recommended grade of oil to the 'high' mark on the dipstick.
- 21 Refill the cooling system.

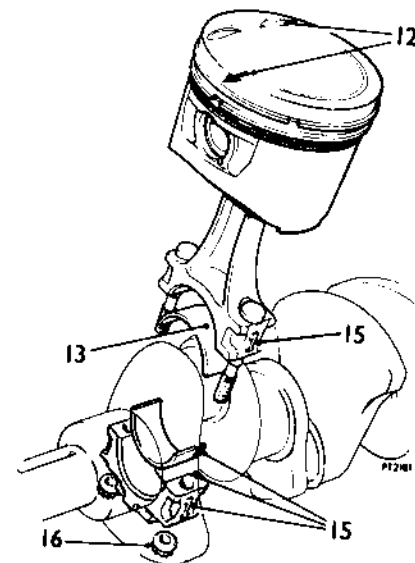
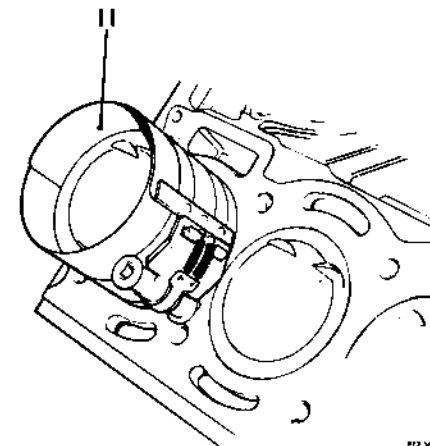



**PISTON ASSEMBLY ENGINE SET**

Remove and refit 12.17.03

See operation 12.17.10.

**CONNECTING RODS AND PISTONS**

Overhaul 12.17.10

Gudgeon pin bush—each—remove and refit 12.17.13

Service tool: 335

**CAUTION:** Do not mix the components during this operation.

**Removing**

1 Remove the connecting rods and pistons, see 12.17.01.

**Dismantling**

- 2 Remove the two gudgeon pin retaining circlips.
- 3 Push out the gudgeon pin and separate the piston from the connecting rod.
- 4 Remove the top, scraper and oil control rings.
- 5 Repeat instructions 2 to 4 on the remaining piston and connecting rod assemblies.
- 6 Degrease all components and remove carbon deposits from the pistons.

**Examination — Pistons and gudgeon pins**

- 7 Check the dimensions 'A', 'B' and 'C' at the points indicated on the illustration across the top of the piston at right angles to the gudgeon pin.
- 8 Check the dimensions 'D' and 'E' across the piston skirt at right angles to the gudgeon pin at the points shown on the illustration.
- 9 Check the dimension of the piston ring grooves and the gap between the piston ring and groove, see DATA.
- 10 Examine the gudgeon pin for scores and pitting. Check for wear, see DATA. The gudgeon pin should be a thumb push-fit in the piston at a temperature of 68°F.

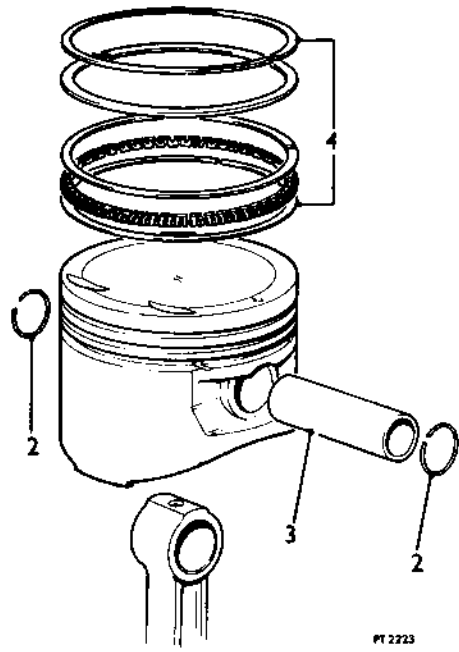

PI 2223

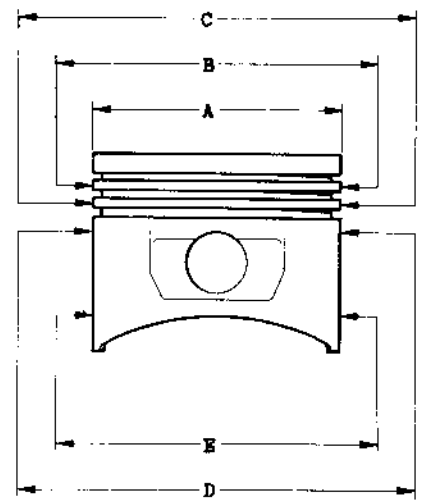

PI 2224

11 Check the top and scraper piston ring gaps when inserted squarely into the bores, see DATA.

**NOTE:** The grade of each cylinder bore, i.e. G or F is stamped on the cylinder block as illustrated. The corresponding piston grades are stamped on the piston crown.

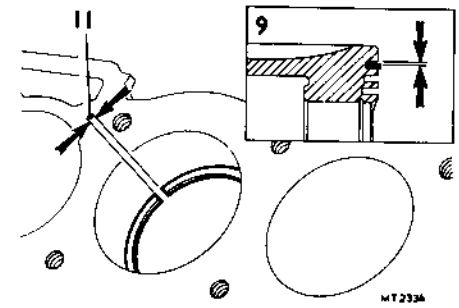

MT 233A

**Examination — Connecting rods**

- 12 Using service tool 335, check the connecting rods for:
  - A. Bend
  - B. Twist
 Rods that exceed the tolerances in DATA should be realigned or renewed.
- 13 Check the gudgeon pin bush for wear and, if necessary, remove the old bush and fit a new one using a suitable press. Ensure that the oil hole in the bush corresponds exactly with the hole in the connecting rod. Ream the new bush to size, see DATA.

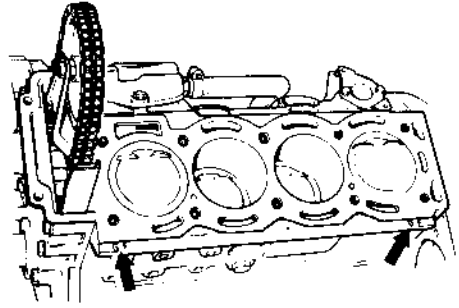

PI 234

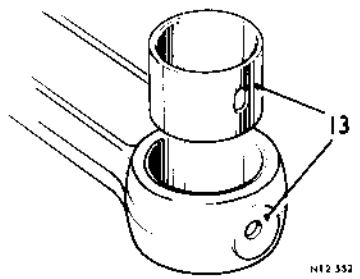

NI 2 352

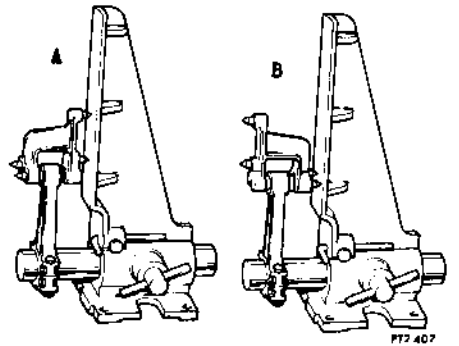

PI 2 407

## Reassembling

- 14 Fit the piston rings in the following order:

**NOTE:** The oil control ring comprises three parts 'A', 'B', and 'C', namely the centre expander rail, flanked by two identical chrome rails.

A. Fit the expander rail into the bottom groove ensuring that the ends butt, but do not overlap.

B. Fit the bottom chrome rail to the bottom groove.

C. Fit the top chrome rail to the bottom groove.

D. Fit the scraper ring to the centre groove in the piston with the word 'TOP' uppermost.

E. Fit the top compression chrome ring to the top groove — stepped edge downwards.

- 15 Refit the pistons to the connecting rods so that the identification numbers and the shell bearing keeper recesses are on the opposite side to the valve head clearance recesses in the piston crown.

- 16 Locate the gudgeon pin with the two circlips ensuring that they fit properly in the grooves.

- 17 Fit the connecting rods and pistons to the engine, see instructions 10 to 21, 12.17.01, ensuring that the sump is refilled with oil to the 'high' mark on the dipstick.

- 18 Refill the cooling system before connecting the battery.

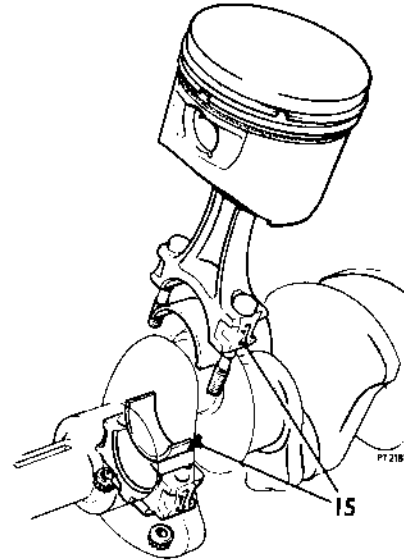
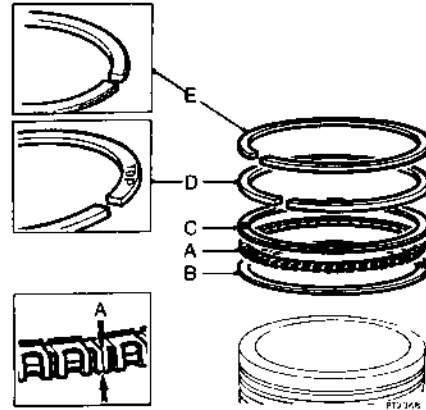

## DATA

### Piston grades and dimensions

Bore size: Grade F	3-5546 in (90-287 mm)
	3-5551 in (90-300 mm)
Grade G	3-5552 in (90-302 mm)
	3-5557 in (90-315 mm)
Piston dia. 'A': Grade F	3-5307 in (89-679 mm)
	3-5319 in (89-709 mm)
Grade G	3-5313 in (89-694 mm)
	3-5324 in (89-724 mm)
Piston dia. 'B': Grade F	3-5346 in (89-779 mm)
	3-5358 in (89-809 mm)
Grade G	3-5354 in (89-799 mm)
	3-5364 in (89-824 mm)

Piston dia. 'C'	3-5079 in (89-100 mm)
	3-5158 in (89-300 mm)
Piston skirt dia. 'D': Grade F	3-5534 in (90-257 mm)
	3-5539 in (90-270 mm)
Grade G	3-5540 in (90-272 mm)
	3-5545 in (90-285 mm)
Piston skirt dia. 'E': Grade F	3-5536 in (90-262 mm)
	3-5541 in (90-275 mm)
Grade G	3-5542 in (90-277 mm)
	3-5547 in (90-290 mm)
Pistons available oversize	0-020 in (0-508 mm)
Piston groove width:	
Top compression	0-0705 in (1-790 mm)
	0-0713 in (1-810 mm)
Second compression	0-0689 in (1-750 mm)
	0-0709 in (1-800 mm)
Oil control	0-1579 in (4-010 mm)
	0-1587 in (4-030 mm)

### Piston rings

Top compression: Width	0-3071 in (7-8 mm)
Thickness	0-0680 to 0-0685 in (1-728 to 1-740 mm)
Diameter	3-5551 in (90-3 mm)
Gap when fitted	0-0138 to 0-0217 in (0-35 to 0-55 mm)

Scraper: Width	0-3071 in (7-8 mm)
Thickness	0-0680 to 0-0685 in (1-728 to 1-740 mm)
Diameter	3-5551 in (90-3 mm)
Gap when fitted	0-0138 to 0-0217 in (0-35 to 0-55 mm)

Oil control — chrome rail: Width	0-135 to 0-141 in (3-429 to 3-581 mm)
Thickness	0-0250 to 0-0230 in (0-635 to 0-584 mm)
Diameter	3-555 in (90-297 mm)
Gap when fitted	0-015 to 0-055 in (0-381 to 1-397 mm)

Oil control — expander rail: Thickness	0-1035 to 0-1075 in (2-629 to 2-731 mm)
Diameter	3-591 to 3-619 in (91-211 to 91-923 mm)
Gap when fitted	Ends to butt

Oversize rings	0-010 + 0-020 in (0-254 + 0-508 mm)
----------------	-------------------------------------

### Gudgeon pin:

Length	66-70 to 67-00 mm (2-626 to 2-638 in)
Diameter	23-811 to 23-815 mm (0-9374 to 0-9376 in)

### Connecting rod:

Small-end bush fitted internal diameter	0-9377 to 0-9380 in (23-818 to 23-825 mm)
Bush external dia.	1-0015 to 1-0025 in (25-438 to 25-464 mm)
Small-end dia. less bush	0-9995 to 1-0005 in (25-387 to 25-413 mm)
Big-end dia. less shells	1-8955 to 1-8960 in (48-146 to 48-158 mm)
Length between centres	5-123 to 5-127 in (130-12 to 130-23 mm)
Maximum bend	0-0015 in (0-038 mm) for length of the gudgeon pin
Maximum twist	0-0015 in (0-038 mm) per inch length of gudgeon pin

## CONNECTING ROD BEARINGS

Remove and refit — set

12.17.16

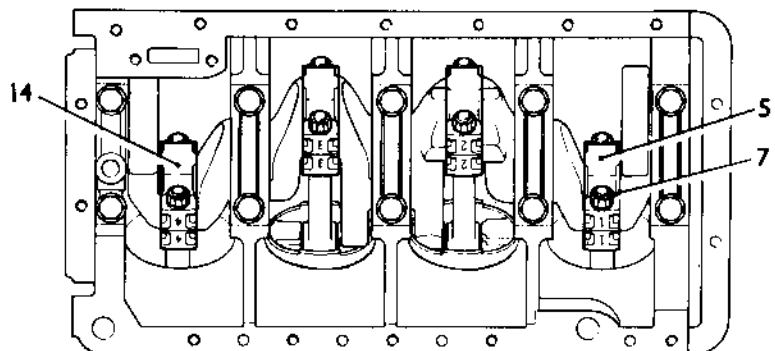
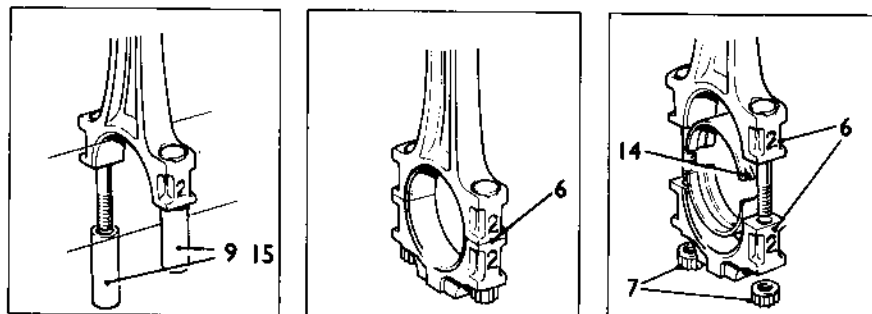

PI1220

### Removing

- 1 Drive the car on to a ramp.
- 2 Disconnect the battery.
- 3 Drain the sump oil, and remove the dipstick.
- 4 Remove the sump and oil strainer, see 12.60.44.
- 5 Turn the engine until Nos. 1 and 4 big-end bearings are in an accessible position.
- 6 Check that the connecting rods and caps are numbered correctly.

**CAUTION:** Do not mix components whilst carrying out the following instructions.

- 7 Remove the two special nuts securing each big-end cap and withdraw the caps complete with lower shells.

- 8 Push the connecting rod upwards sufficiently to enable the upper shell bearing to be removed.

- 9 Fit rubber or plastic sleeves over the big-end bolts to prevent damage being caused to the crankpins.
- 10 Turn the crankshaft sufficiently to bring Nos. 3 and 4 big-end bearings to an accessible position.
- 11 Repeat instructions 6 to 9 on Nos. 2 and 3 big-ends.

### Refitting

- 12 Clean Nos. 2 and 3 crankpins and corresponding bearings and caps.
- 13 Fit the upper bearing shell to the connecting rod, ensuring that the keeper tags locate in the connecting rod recess and pull the rod onto the crankpin.

- 14 Fit the lower bearing shell to the cap, ensuring that the keeper tag locates correctly in the connecting rod recess.
- 15 Remove the protective sleeves from the connecting rod bolts and fit the bearing cap, checking that:
  - a the correct number cap is being fitted to the connecting rod concerned.
  - b the keeper tags are adjacent, i.e. on the same side of the bearing.
- 16 Fit and evenly tighten new nuts to the correct torque figure, see 'TORQUE WRENCH SETTINGS'.
- 17 Turn the crankshaft to bring Nos. 1 and 4 big-ends to an accessible position.
- 18 Repeat instructions 12 to 16 on Nos. 1 and 4 big-ends.
- 19 Fit the sump and oil strainer, see 12.60.44.
- 20 Lower the ramp and fill the sump to the 'high' mark on the dipstick with oil of a recommended grade.
- 21 Reconnect the battery.
- 22 Drive the car from the ramp.

## CRANKSHAFT PULLEY

Remove and refit

12.21.01

### Removing

- 1 Isolate the battery.
- 2 Remove the fan belt.
- 3 Remove the crankshaft pulley retaining bolt and plain washer.
- 4 Withdraw the pulley.

### Refitting

- 5 Remove any burrs from the pulley key-way and crankshaft key and fit the pulley.
- 6 Secure the pulley with the special bolt and plain washer.
- 7 Reverse instructions 1 and 2.

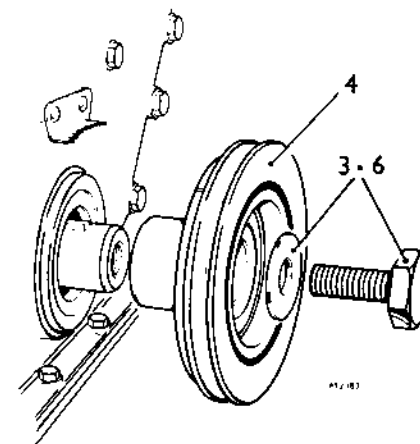

PI1103

## CRANKSHAFT REAR OIL SEAL

Remove and refit

12.21.20

### Removing

- 1 Remove the gearbox, see 37.20.01.
- 2 Remove the clutch assembly, see 33.10.01.
- 3 Remove the flywheel, see instructions 4 to 6, 12.53.07.
- 4 Remove the six bolts securing the rear main oil seal housing to the crankcase.
- 5 Remove the two rear, sump to seal housing, bolts, and remove the housing.
- 6 Press out the old oil seal from the housing.

### Refitting

- 7 Press a new seal into the housing so that the lip faces the crankcase.
- 8 Clean the crankcase and seal housing mating faces and using sealing compound, fit a new gasket.
- 9 Lubricate the crankshaft and carefully ease the seal into position, locating the housing on the two dowels.
- 10 Fit the six retaining bolts loosely, noting that the two lower opposing bolts are longer.
- 11 Evenly tighten the bolts to the correct torque, see Section 06.
- 12 Fit and tighten the two rear, sump to seal housing, bolts.
- 13 Fit the flywheel, see instruction 7 and 8, 12.53.07.
- 14 Fit the clutch assembly, see 33.10.01.
- 15 Fit the gearbox, see 37.20.01.

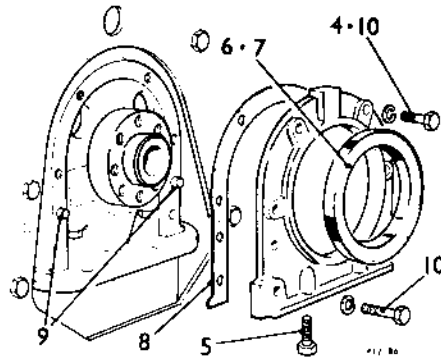

- 4 Lever the crankshaft rearwards.
- 5 Zero the dial gauge and lever the crankshaft forward and note the reading.
- 6 Repeat instructions 4 and 5 several times until a constant reading is achieved, see DATA.
- 7 Remove the dial gauge and magnetic base.

### Adjusting

- 8 Drain the sump oil and remove the dipstick.
- 9 Remove the sump, see 12.60.44.
- 10 Remove two bolts and withdraw No. 3 main bearing cap and lower shell.
- 11 Using the blade of a thin screwdriver and taking care not to damage the crankshaft, remove the two crankshaft thrust bearings.
- 12 Lubricate and feed the thrust bearings of the appropriate size into the channel, reversing the method of removal. Ensure, however, that the two grooves in the thrust bearing face outwards away from the bearing cap.
- 13 Fit the main bearing cap and lower shell, ensuring that the keeper recesses in the cap and crankcase are adjacent. Temporarily tighten the two retaining bolts.
- 14 Using a feeler gauge or clock gauge check the crankshaft end-float by levering the crankshaft forwards or rearwards.
- 15 Repeat instructions 10 to 14 if necessary to achieve the correct end-float.
- 16 Finally tighten the No. 3 main bearing cap bolts to the correct torque figure, see 'TORQUE WRENCH SETTINGS'.
- 17 Refit the sump, see 12.60.44.
- 18 Refill the sump to the 'high' mark on the dipstick with oil of a recommended grade.
- 19 Lower the car.
- 20 Connect the battery.

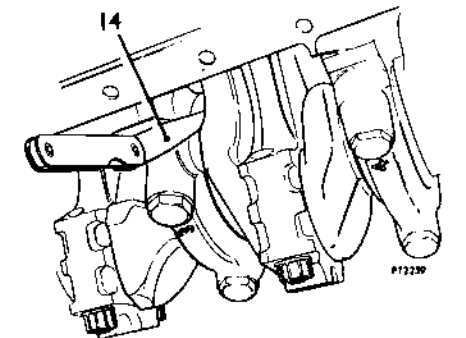
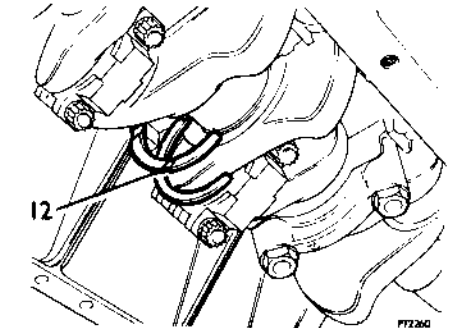
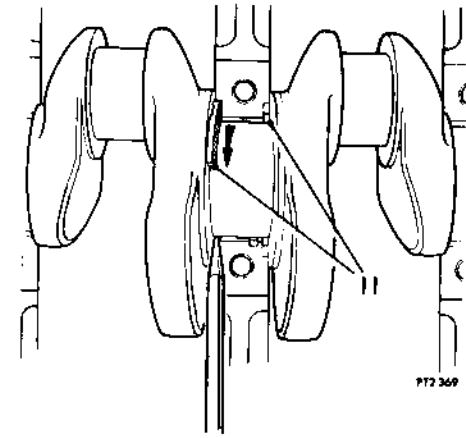

## CRANKSHAFT END-FLOAT

Check and adjust

12.21.26

### Checking

- 1 Raise the car on a ramp.
- 2 Disconnect the battery.
- 3 Attach the magnetic base of a dial gauge stand to the underside of the sump and arrange the dial gauge so that the stylus rests in a loaded condition on the front face of the crankshaft pulley.

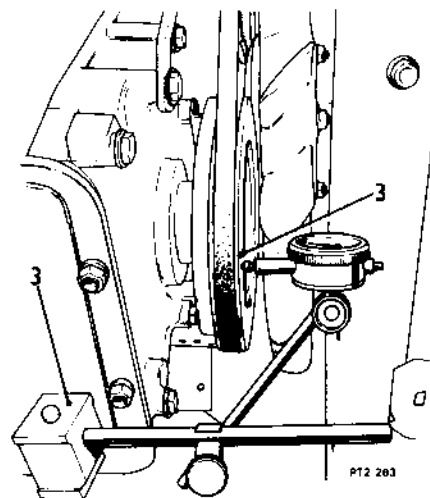

### DATA

Crankshaft end-float . . . . .  
Adjustment . . . . .

0.003 to 0.011 in (0.07 to 0.28 mm)  
By selective thrust bearings 0.005 in  
(0.127 mm)

## CRANKSHAFT

Remove and refit

12.21.33

## Removing

- 1 Remove the engine and gearbox assembly from the car, see 12.37.01.
- 2 Lift the assembly onto a workbench.
- 3 Remove the gearbox.
- 4 Remove the six bolts and withdraw the clutch assembly and centre plate.
- 5 Remove the starter motor.
- 6 Remove the exhaust manifold complete with front pipe.  
**NOTE:** The above two items are removed to enable the engine to be positioned safely on its side.
- 7 Remove the fan units and drive belt.
- 8 Remove the alternator and adjustment link.
- 9 Remove the crankshaft pulley.
- 10 Remove the timing cover, noting the position of all the attachment bolts for reassembly.
- 11 Remove the rocker cover, see 12.29.42.
- 12 Lay the engine over on its L.H. side.
- 13 Remove the sump and dipstick.
- 14 Remove the eight bolts securing the flywheel to the crankshaft and withdraw them complete with the spigot bush retaining plate.
- 15 Using a centre punch, mark for re-assembly the relationship of the flywheel to the crankshaft flange, and withdraw the flywheel.

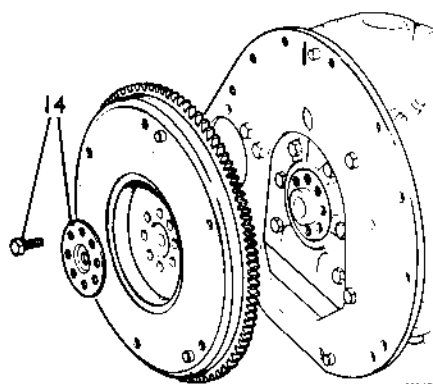
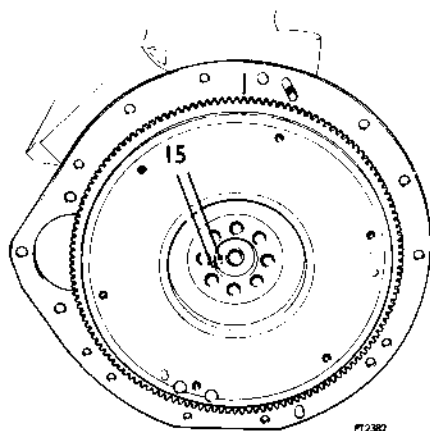
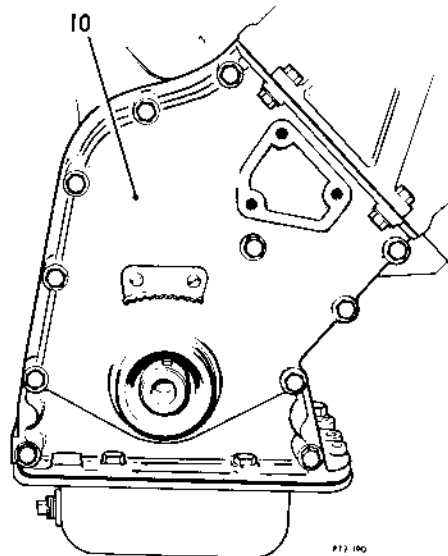
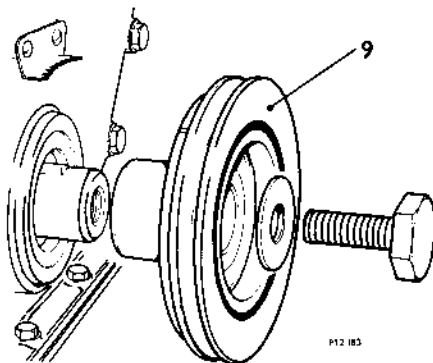

- 16 Withdraw the six bolts and the two rear sump bolts and remove the rear main oil seal housing and, if necessary, remove the seal for renewal.

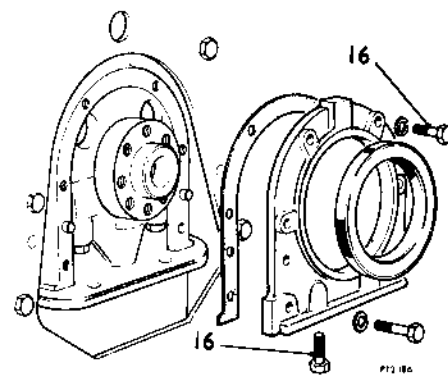

- 17 Remove the oil pick-up pipe.
- 18 Remove the bearing caps and lower shells of Nos. 1 and 4 connecting rods, and push the pistons up the bores. **DO NOT MIX.**

**CAUTION:** Fit suitable plastic or rubber protective sleeves over the exposed connecting rod bolts to prevent damage being caused to the crankshaft journals, see Illustration 'A'.

- 19 Turn the crankshaft over and repeat instruction 18 on Nos. 2 and 3 connecting rods taking note of the caution.
- 20 Turn the crankshaft until the timing mark on the camshaft flange is in line with the groove on the camshaft front bearing cap.
- 21 Remove the oil thrower.
- 22 Remove the two bolts and withdraw the hydraulic timing chain tensioner.
- 23 Remove the front lifting eye.
- 24 Withdraw the chain guide attachment bolts and remove:
  - a the fixed guide
  - b the adjustable guide
  - c the camshaft sprocket support bracket.

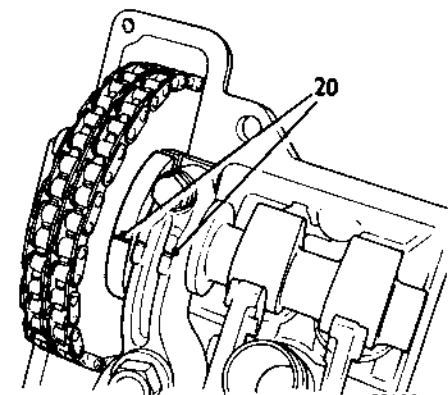
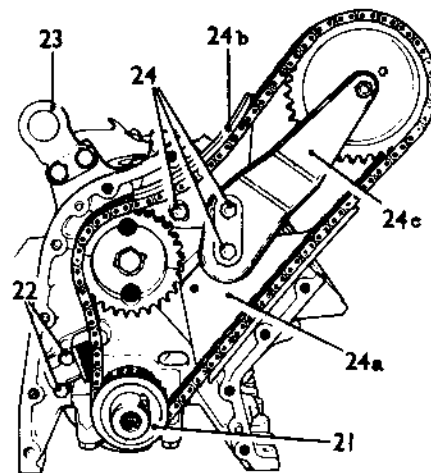
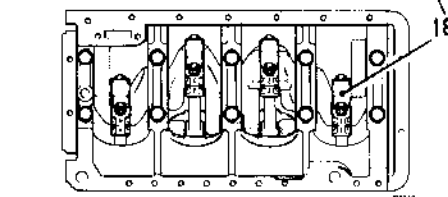
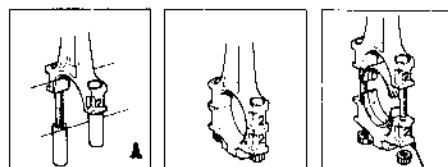

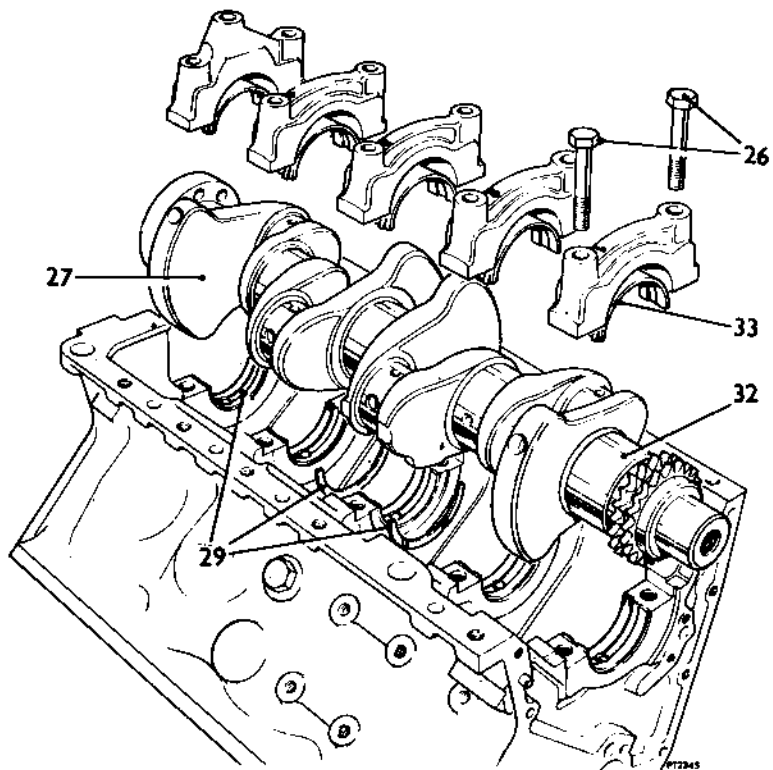

- 25 Ease the crankshaft sprocket forward whilst removing the timing chain from the jackshaft sprocket.
- 26 Remove the main bearing cap retaining bolts and withdraw the caps complete with the lower shells. **DO NOT MIX.** Note that the caps are numbered 1 to 4 from the front of the cylinder block.
- 27 Lift out the crankshaft.
- 28 Remove from the crankshaft:
  - a the sprocket
  - b the key
  - c the shims
  - d the spigot bush.
- 29 Remove the thrust washers and the upper shells from the crankcase.

#### Refitting

- 30 Clean and fit the upper shells to the crankcase ensuring that the keeper tags locate in the recesses.

- 31 Fit the thrust washers to No. 3 main bearing, ensuring that the oil grooves face outwards.
- 32 Clean and lubricate the main bearing journals and lower the crankshaft into the crankcase.
- 33 Clean and fit the main bearing shells to the caps ensuring that the keeper tags locate in the cap recesses.
- 34 Fit the main bearing caps to the crankcase, and partially tighten the securing bolts, ensuring that the caps are fitted to their correct crankcase bearings.
- 35 Check the crankshaft end-float, see DATA, by inserting a feeler gauge between the crankshaft and the thrust washers in No. 3 bearings, see 12.21.26, instruction 14.
- 36 Tighten the ten main bearing bolts to the correct torque.
- 37 Clean and lubricate the crankshaft

journals, pull the connecting rods and upper shells on to the journals and remove the protective sleeves from the bolts.

- 38 Clean and fit the connecting rod caps, ensuring:
    - a the caps are fitted to their correct connecting rods
    - b the keeper tags in the rods and caps are adjacent
    - c the nuts are tightened to the correct torque.
    - d the pistons are not pushed up to where they could foul open valves.
  - 39 If necessary fit a new seal to the rear main oil seal housing, ensuring that the lip faces the crankshaft flange.
  - 40 Using a new gasket fit the oil seal housing, locating it on the two dowels. Secure with the six bolts and spring washers noting that the two lower bolts are longer.
  - 41 Fit the spigot bush.
  - 42 Fit the flywheel so that the punch marks align and secure with the retaining plate and eight bolts.
  - 43 Turn the flywheel to bring Nos. 1 and 4 pistons to T.D.C. indicated by the mark on the flywheel coinciding with the vertical line on the adaptor plate.
- CAUTION:** To prevent the pistons fouling the valves ensure that Nos. 2 and 3 pistons are not allowed to reach T.D.C. whilst turning the crankshaft.

- 44 Temporarily fit the crankshaft sprocket and check its alignment with the jackshaft sprocket, using a straight-edge. Adjust by fitting shims behind the crankshaft sprocket.

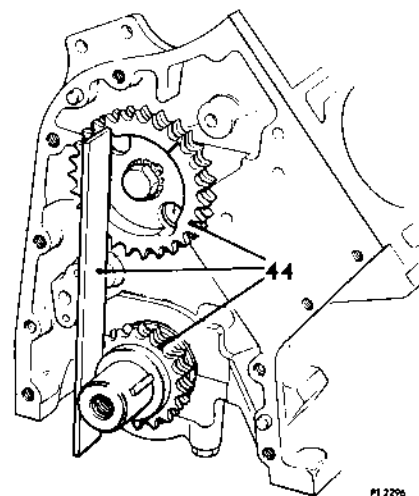
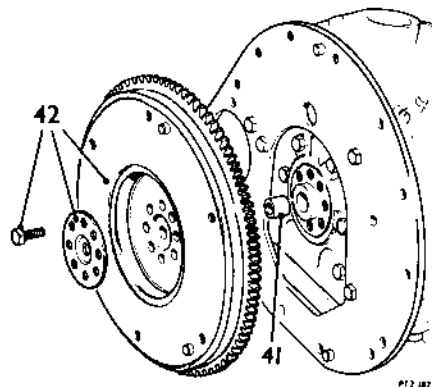
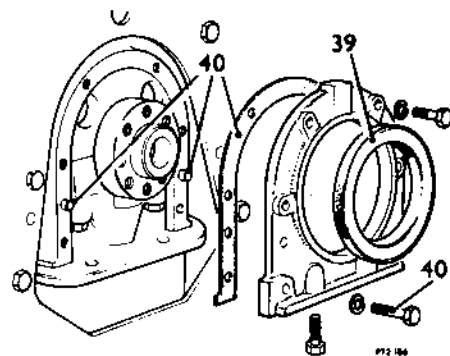
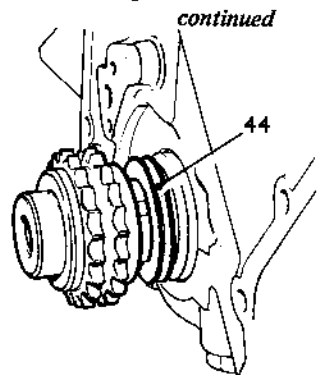

continued

- 13 Fit the cap to the crankcase, noting that the keeper tag is fitted adjacent to its counterpart in the crankcase.
- 14 Secure the cap with the bolts and tighten evenly to the correct torque figure, see Division 06.
- 15 Repeat instructions 11 to 14 on the remaining bearings.
- 16 Check, and if necessary adjust, the crankshaft end-float, see 12.21.26.
- 17 Fit the sump and oil strainer pipe, see 12.60.44.
- 18 Lower the ramp and fill the sump with oil of a recommended grade to the 'high' mark on the dipstick.
- 19 Reconnect the battery.
- 20 Drive the car from the ramp.

### SPIGOT BUSH

Remove and refit 12.21.45

#### Removing

- 1 Remove the gearbox, see 37.20.01.
- 2 Remove the clutch assembly, see 33.10.01.
- 3 Remove the eight flywheel retaining bolts.
- 4 Remove the spigot bush retaining plate.
- 5 Remove the spigot bush.

#### Refitting

- 6 Insert the spigot bush into the crankshaft bore.
- 7 Fit the spigot bush retaining plate and the eight flywheel securing bolts; tighten to the correct torque figure, see Division 06.
- 8 Refit the clutch assembly, see 33.10.01.
- 9 Refit the gearbox, see 37.20.01.

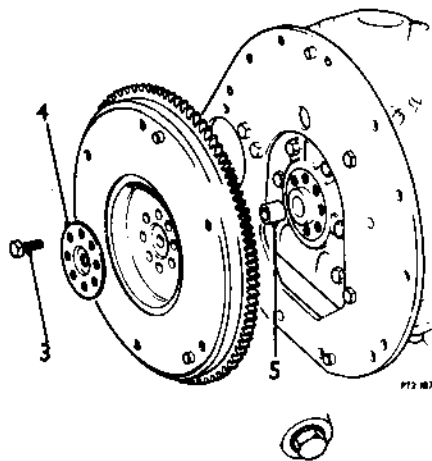

### CYLINDER BLOCK DRAIN PLUG

Remove and refit 12.25.07

#### Removing

- 1 Drive the car on to a ramp and disconnect the battery.
- 2 Drain the radiator.
- 3 Raise the ramp.
- 4 Slowly unscrew the cylinder block plug, allowing the coolant to flow into a suitable container.
- 5 When the coolant flow lessens, remove the plug and sealing washer completely.

#### Refitting

- 6 Clean the plug and cylinder block mating face and fit the plug and a new sealing washer and tighten.
- 7 Lower the ramp and refill the cooling system, see 26.10.01.
- 8 Reconnect the battery.

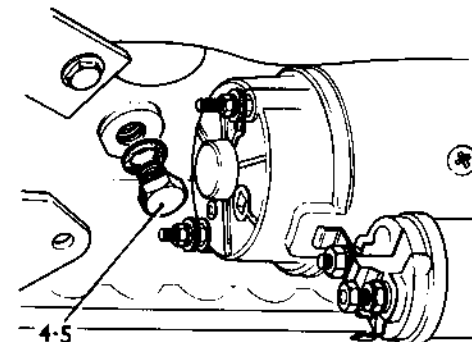

### CYLINDER HEAD GASKET

Remove and refit 12.29.02

Cylinder head—remove and refit 12.29.11

#### Removing

- 1 Disconnect the battery.
- 2 Drain the cooling system.
- 3 Remove the inlet manifold complete with carburetters and air cleaner, see 30.15.02.
- 4 Remove the rocker cover, see 12.29.42.
- 5 Disconnect the exhaust pipe from the manifold flange.
- 6 Turn the engine over so that the timing mark on the camshaft flange is 180° distant from the groove on the camshaft front bearing cap, thus bringing one of the sprocket retaining bolts to an accessible position.
- 7 Unlock the tab washer and remove the one accessible sprocket retaining bolt.
- 8 Again turn the engine over so that the timing mark on the camshaft flange is in line with the groove on the camshaft front bearing cap.

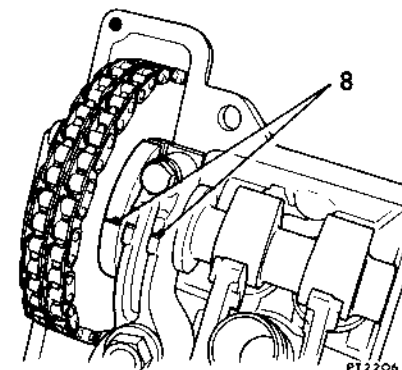

continued

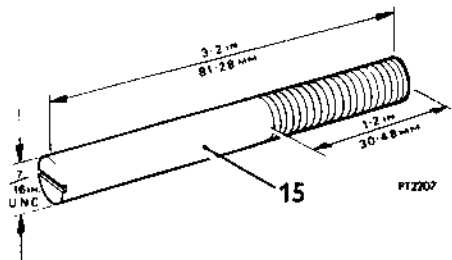
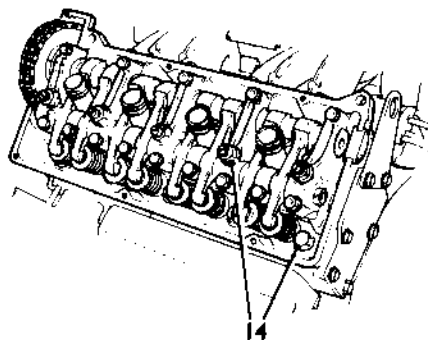
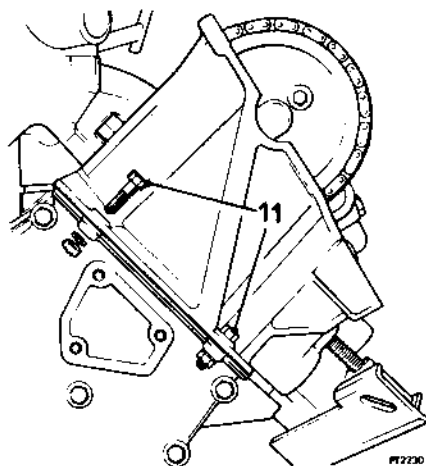
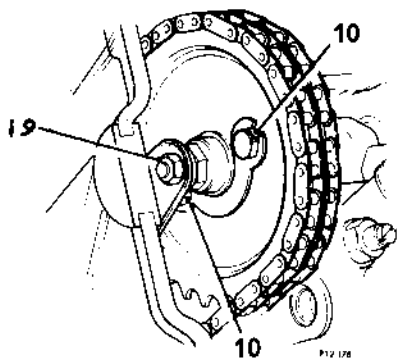

- 9 Anchor the camshaft sprocket to the support bracket.
  - 10 Bend back the lock plate tab and remove the remaining sprocket retaining bolt.
  - 11 Remove the two nuts and bolts securing the cylinder head to the timing cover.
  - 12 Disconnect the heater hose from the water transfer housing.
  - 13 Slacken the cylinder head nuts and bolts in the reverse order to that shown in operation 12.29.27.
  - 14 Remove the nuts and plain washers and remove the studs.
  - 15 Remove the centre bolt and washer and in its place fit a special guide stud to facilitate the removal and replacement of the cylinder head.
- NOTE:** A suitable guide stud may be made to the dimensions illustrated. To enable the stud to be inserted and withdrawn, a slot, to accommodate a screwdriver blade, should be made in one end.
- 16 Remove the remaining bolts and plain washers and lift off the cylinder head.
  - 17 Remove and discard the cylinder head gasket.

#### Refitting

- 18 Clean the cylinder block and cylinder head mating faces.

- 19 Place a new cylinder head gasket in position on the cylinder block, locating it over the temporary guide stud.
- 20 Check that the timing mark on the camshaft flange is in line with the groove on the camshaft front bearing cap and lower the cylinder head into position.
- 21 Fit the five cylinder head studs and loosely fit the nuts and washers.
- 22 Remove the guide stud and fit the five cylinder head bolts and plain washers, leaving them loose.
- 23 Tighten the nuts and bolts to the correct torque, see '**TORQUE WRENCH SETTINGS**', in the sequence shown in operation 12.29.27.
- 24 Secure the camshaft sprocket to the camshaft with one of the two retaining bolts, using a new lock plate.
- 25 Release the sprocket from the support bracket and check that the threaded spigot does not foul the bracket.
- 26 Turn the engine over sufficiently to enable the second retaining bolt to be fitted and locked.
- 27 Turn the engine over again to enable the first bolt to be finally tightened and locked.
- 28 Fit the two bolts and nuts securing the cylinder head to the timing cover.
- 29 Reconnect the exhaust pipe to the manifold flange.
- 30 Connect the heater hose to the water transfer pipe.
- 31 Fit the inlet manifold complete with carburetters and air cleaner, see 19.15.15.
- 32 Refit the rocker cover, see 12.29.42.
- 33 Fill the cooling system and reconnect the battery.

**NOTE:** After 1,000 miles (1600 km) running, check the cylinder head fixings for tightness as follows:

- 34 a Remove the rocker cover, see 12.29.42.
- b Working in the sequence shown in operation 12.29.27, slacken each nut/bolt by approximately one flat (one-sixth turn) and then tighten it to the correct torque, see '**TORQUE WRENCH SETTINGS**'.
- c Refit the rocker cover, see 12.29.42.

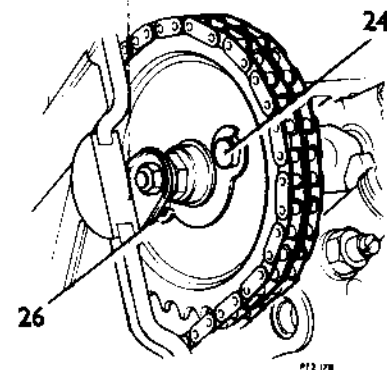
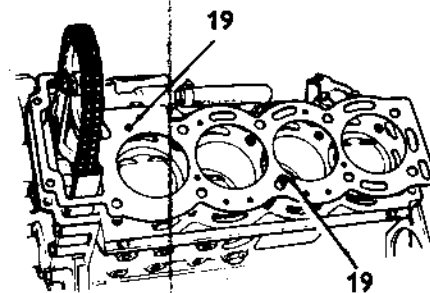



## CYLINDER HEAD

<b>Overhaul</b>	<b>12.29.19</b>
Which includes:	
Valves — exhaust — remove and refit	12.29.64
Valves — inlet and exhaust — remove and refit	12.29.62
Valves — inlet — remove and refit	12.29.63
Valve guides — inlet — remove and refit	12.29.70
Valve guides — exhaust — remove and refit	12.29.71
Inlet valve seats — remove and refit	12.29.76
Exhaust valve seats — remove and refit	12.29.77

Service tools: 60A with S 60A-9, 18G 106 and S 352

### Removing

- 1 Remove the cylinder head, see 12.29.10.
- 2 Remove the exhaust manifold.
- 3 Withdraw the spark plug tubes.
- 4 Remove the spark plugs.
- 5 Remove the fourteen bolts and five nuts and lift off the rocker shaft assembly.
- 6 Remove the camshaft.
- 7 Withdraw the tappets, identifying for reassembly.
- 8 Remove the pallets from the inlet valves ensuring that they are identified for reassembly.
- 9 Remove the exhaust valve pallets, identifying for reassembly.

**NOTE:** A convenient method of identifying the pallets is to stick them to a strip of gummed tape or paper, numbering 1 to 8, using separate strips for the inlet and exhaust pallets.

- 10 Using the valve spring compressor remove the exhaust valves, springs and collars. Identify the valves for reassembly.
- 11 Remove the inlet valves, springs and collars using the same tool.

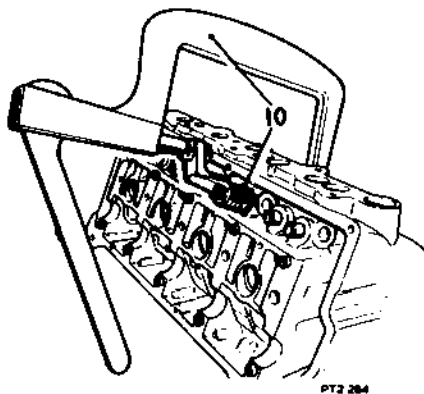
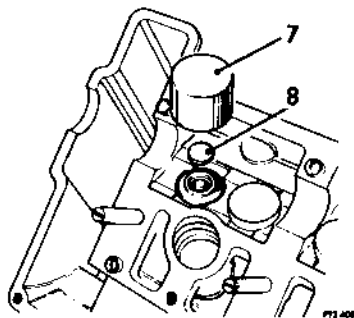
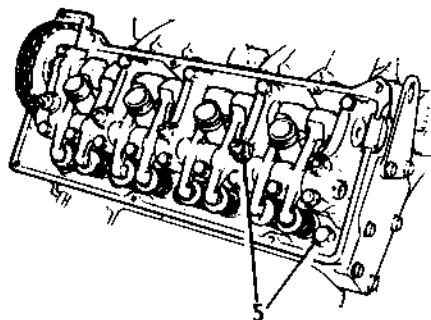

### Valve guides — checking

- 12 Check the inlet and exhaust valve guides for wear by inserting a new valve in each guide in turn and tilting it. If movement across the valve seat — dimension 'A' — exceeds 0.020 in (0.508 mm), the valve guide should be renewed.

### Valve guides — removing inlet and exhaust

- NOTE:** The removal and fitting of valve guides is best carried out using service tool 60A with the appropriate adaptors S 60A-9.
- 13 Assemble the main tool 60A on the top face of the cylinder head with adaptors numbers S 60A/1/4/5 as illustrated. Tension the assembly with the top handle and withdraw the valve guide by turning the lower handle clockwise.

### Valve guides — fitting — inlet

- 14 Apply graphite grease to the cylinder head and valve guide and assemble the main tool 60A on the combustion face with adaptor numbers S 60A/2/4/5 and the new valve guide positioned as illustrated.
- 15 Tension the assembly with the top handle and draw in the new guide by turning the lower handle, until the shoulder butts against the cylinder head mating face.

*continued*

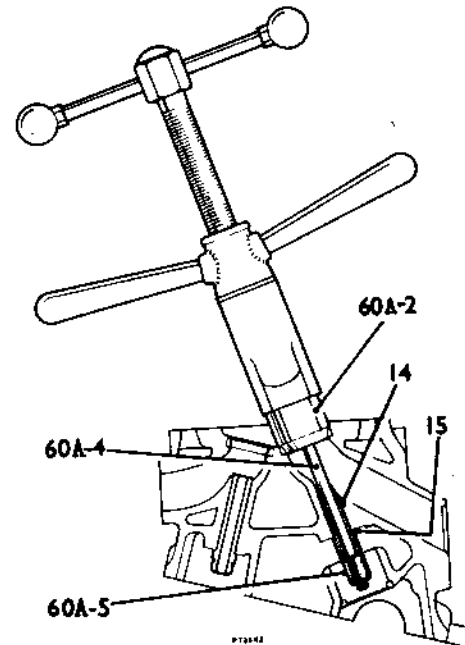
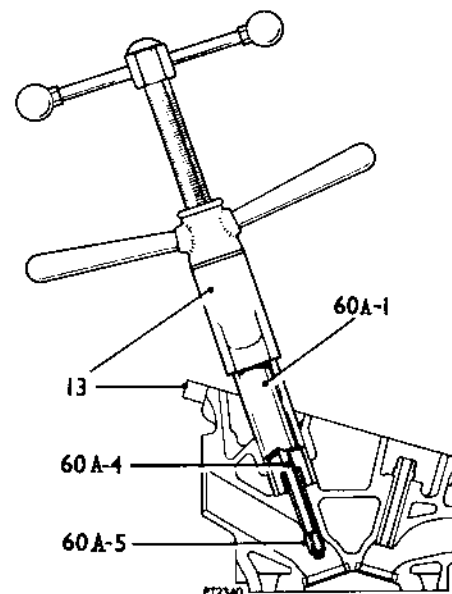
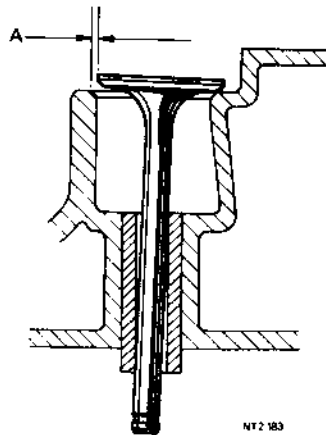

**Valve guide — fitting — exhaust**

16 Apply graphite grease to the cylinder head and valve guide and assemble the tool and adaptor numbers S 60A—3/4/5 and the new guide as illustrated. Draw in the guide as in instruction 15 until the shoulder butts against the cylinder head mating face.

**Valve guides — reaming — inlet and exhaust**

17 Ream the new valve guides to size, using a  $\frac{1}{4}$  in (6.74 mm) taper reamer followed by a parallel  $\frac{1}{8}$  in (7.14 mm) reamer.

**CAUTION:** It is essential that after fitting new valve guides the corresponding valve seats are re-cut or the inserts renewed and machined concentric with the new guides.

**NOTE:** On some engines, seals are fitted with the exhaust valve guide.

**Valves**

18 Examine the valves and discard any with worn or bent stems and badly pitted or burnt heads. Valves with the head thickness reduced to 0.015 in (0.40 mm) — dimension 'A' — should be renewed. Valves in an otherwise satisfactory condition may be refaced.

**Valve Springs**

19 Examine the valve springs for cracks and distortion. Check the springs against the information in DATA and discard any that do not meet these requirements.

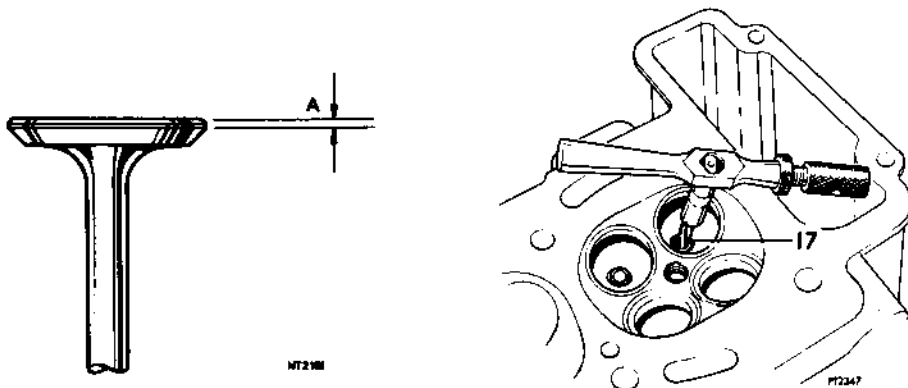
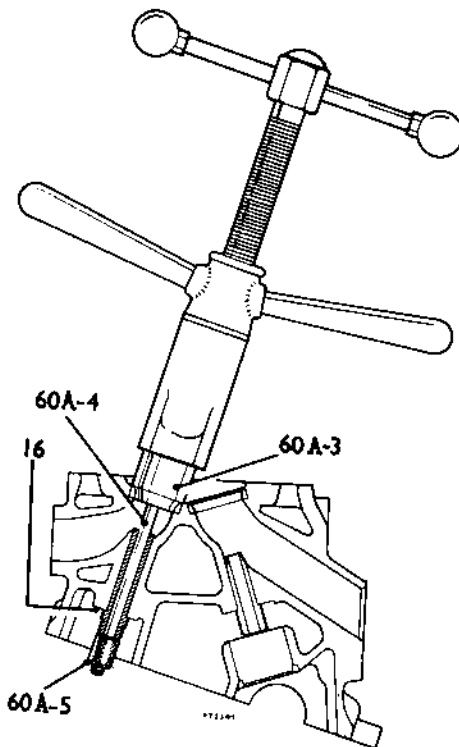
**Valve seat inserts**

20 Examine the valve seat inserts for wear, pits, scores and pocketing. Reface where necessary, removing only the minimum of material to obtain a gas-tight seal and a correctly seating valve.

A. Correctly seating valve.

B. Incorrectly seating valve.

21 Valve seat inserts that cannot be restored by machining to provide a correctly seating valve must be renewed as follows:

22 Machine out the existing inserts, taking care not to damage the insert bores in the cylinder head.

23 Machine the INLET valve seat bore in the cylinder head, dimension 'A', to 1.430 to 1.429 in (36.32 to 36.29 mm) diameter to a depth of 0.250 to 0.255 in (6.35 to 6.45 mm), dimension 'B'.

24 Machine the cylinder head EXHAUST valve seat bore, dimension 'C', to 1.282 to 1.281 in (32.56 to 32.53 mm) diameter to a depth of 0.250 to 0.255 in (6.35 to 6.45 mm), dimension 'D'.

25 Heat the cylinder head uniformly to a maximum temperature of 180°C and immediately fit the new inlet and exhaust valve seat inserts.

26 Allow the cylinder head to cool and machine the INLET valve seat insert to an inclusive angle of 89° and a seat width of 0.080 in (2.03 mm), dimension 'A'.

27 Machine the EXHAUST valve seat insert to an inclusive angle of 89° and a seat width of 0.080 in (2.03 mm), i.e. dimension 'A' as in instruction 26.

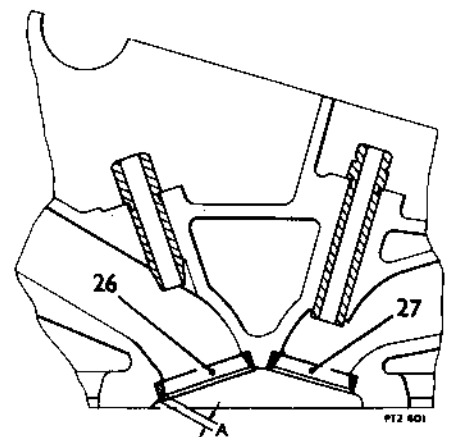
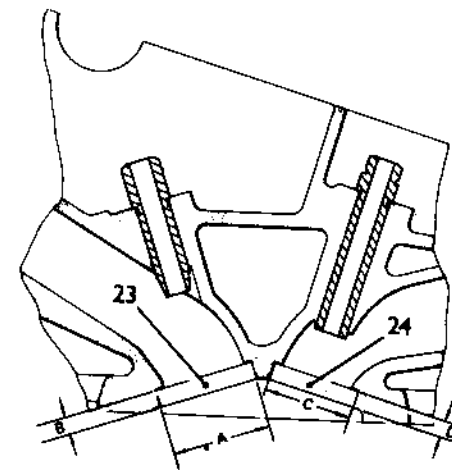

### Lapping-in the valves

- 28 Insert each valve in turn in its guide and lap in using coarse followed by fine carborundum compound, until a continuous narrow band is obtained round the valve face and its seating.
- 29 Clean off all traces of compound from the valves and inserts.

### Reassembly

- 30 Lubricate and fit the INLET valves, illustration 'A', and assemble as follows:
  - a Lower collar
  - b Spring
  - c Top collar.
 Compress the springs using service tool 18G106 and retain with the split collets.
- 31 Lubricate and fit the EXHAUST valves, illustration 'B', and assemble as follows:
  - a Lower collar
  - b Seal
  - c Spring
  - d Top collar.
 Compress the springs and secure with the split collets.
- 32 Fit the pallets and tappets to the inlet valves.
- 33 Fit the pallets to the exhaust valves.
- 34 Fit the camshaft, see 12.13.01.
- 35 Fit the rocker shaft assembly and tighten the retaining bolts to the correct torque, see instructions 9 to 13, 12.29.54, omitting instruction 10.
- 36 Fit the exhaust manifold.
- 37 Fit the cylinder head, see instructions 19 to 24, 12.29.10.
- 38 Check, and if necessary adjust, the valve clearances, see 12.29.48.
- 39 Refill the cooling system.
- 40 Reconnect the battery.

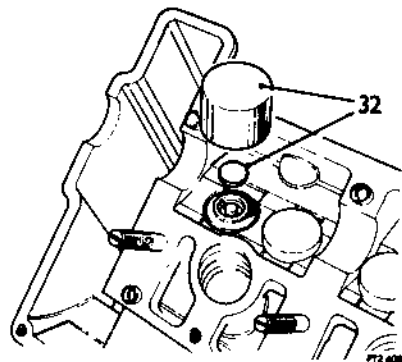
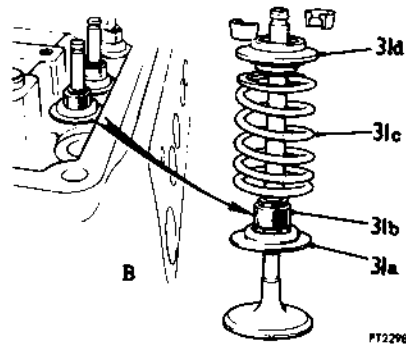
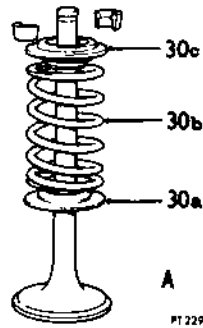

### DATA

#### Valves

	Inlet	Exhaust
Head diameter . . . . .	1.38 in (35.05 mm)	1.21 in (30.73 mm)
Stem diameter . . . . .	0.2794 to 0.2800 in (7.097 to 7.112 mm)	0.2787 to 0.2793 in (7.078 to 7.094 mm)
Length . . . . .	4.422 to 4.432 in (112.31 to 112.57 mm)	4.518 to 4.528 in (114.75 to 115.01 mm)
Seat angle . . . . .	45°	45°

#### Valve springs

Free length (approx.) . . . . .	1.60 in (40.64 mm)
Solid length . . . . .	1.013 in (25.73 mm)
Fitted length . . . . .	1.44 in (36.58 mm)
Number of working coils fitted . . . . .	3½
Wire diameter . . . . .	0.162 in (4.11 mm)
Inside diameter of coils . . . . .	0.800 in (20.32 mm)

#### Cylinder head machining dimensions

Inlet valve seat bore — dimension 'A' . . . . .	1.430 to 1.429 in (36.32 to 36.29 mm)
Inlet valve seat bore depth — dimension 'B' . . . . .	0.250 to 0.255 in (6.35 to 6.45 mm)
Exhaust valve seat bore — dimension 'C' . . . . .	1.281 to 1.282 in (32.53 to 32.56 mm)
Exhaust valve seat bore depth—dimension 'D' . . . . .	0.250 to 0.255 in (6.35 to 6.45 mm)

#### Valve seat inserts

	Inlet	Exhaust
Outside diameter . . . . .	1.4235 to 1.4245 in (36.157 to 36.182 mm)	1.2755 to 1.2765 in (32.397 to 32.413 mm)
Height . . . . .	0.248 to 0.250 in (6.29 to 6.35 mm)	0.248 to 0.250 in (6.29 to 6.35 mm)
Seat angle . . . . .	89° inclusive angle	89° inclusive angle
Seat width . . . . .	0.060 in (1.524 mm)	0.080 in (2.032 mm)

**CYLINDER HEAD NUTS****Tighten** 12.29.27

- 1 Remove the camshaft cover, see 12.29.42.
- 2 To avoid distortion, tighten the five cylinder head retaining nuts and five bolts to the correct torque, see Division 06, in the following sequence: A, B, C, D, E, F, G, H, I, J.
- 3 Refit the rocker cover, see 12.29.42.

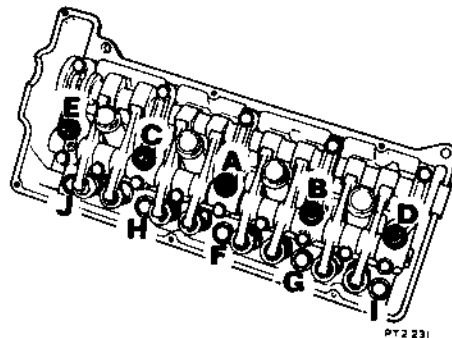
**CAMSHAFT COVER****Remove and refit** 12.29.42**Removing**

- 1 Disconnect the breather pipe from the camshaft cover elbow.
- 2 Withdraw the four H.T. leads and connectors.
- 3 Remove the six screws securing the camshaft cover to the cylinder head.
- 4 Lift off the camshaft cover.

**Refitting**

- 5 Reverse instructions 1 to 4. Ensure that the camshaft cover gasket is in sound condition and is properly located.

**VALVE CLEARANCES****Check and adjust** 12.29.48**Check**

- 1 Remove the camshaft cover, see 12.29.42.
- 2 Pull out the spark plug tubes.
- 3 To assist in checking the valve clearances stick a length of gummed paper along the top edge of the cylinder head as illustrated and make suitable marks or record the clearances as the valves are checked.
- 4 Turn the engine to close No. 1 cylinder inlet valves and check and record:
  - a No. ONE inlet, see DATA
  - b No. THREE exhaust.

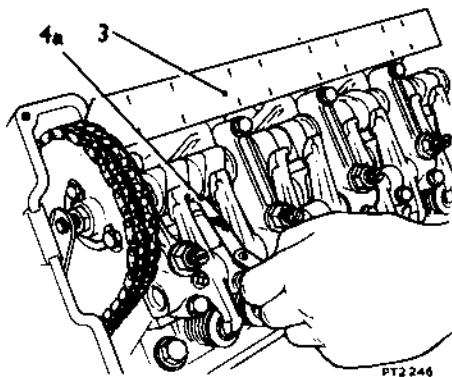

- 5 Close No. 3 inlet valves and check and record:
  - a No. THREE inlet
  - b No. FOUR exhaust.
- 6 Close No. 4 inlet valves and check and record:
  - a No. FOUR inlet
  - b No. TWO exhaust.
- 7 Close No. 2 inlet valves and check and record:
  - a No. TWO inlet
  - b No. ONE exhaust.

**Adjusting**

- 8 Disconnect the battery.
- 9 Drain the cooling system.
- 10 Remove the camshaft and rocker shaft, see instructions 3 to 10, 12.13.01.
- 11 Turn the engine back 90° from T.D.C., thereby positioning the pistons half-way in the bores to prevent them being fouled by the valves during ensuing instructions.
- 12 Remove the tappets of the inlet valves that require adjustment.
- 13 Remove the pallets of the inlet and exhaust valves that require adjustment. Using a micrometer, measure and record the thickness of each pallet taken out.

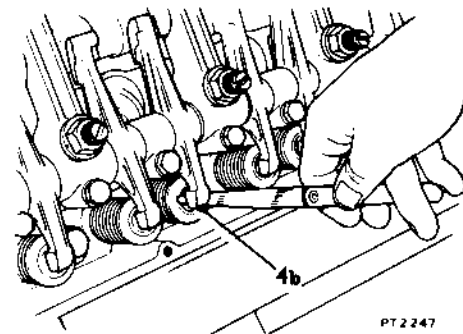

PT 2247

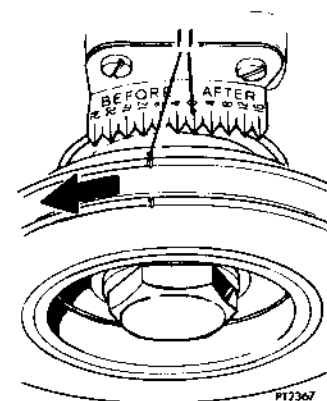

PT 2367

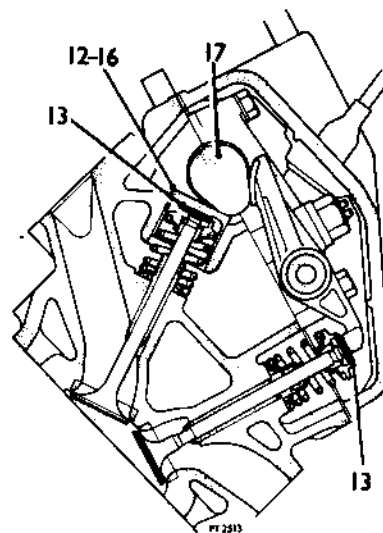

PT 2313

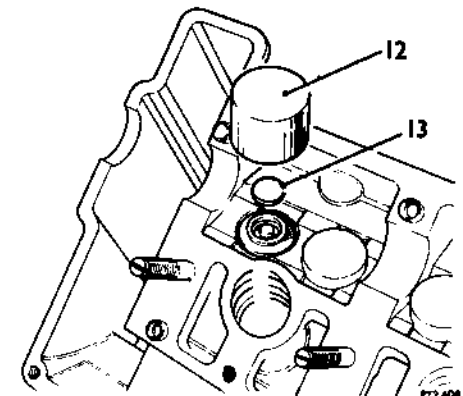

PT 2408

14 Using the following procedure as an example, select the appropriate new pallet to give the correct valve clearance, see DATA. The procedure is the same for both inlet and exhaust valves.

a Excessive clearance:

	inch
Valve clearance recorded	0-023
Valve clearance required	0-018
	—
Valve clearance excess	+0-005
Plus pallet thickness recorded	0-090
	—
	0-095
	—
=Pallet thickness required	0-095

b Insufficient clearance

	inch
Valve clearance recorded	0-015
Valve clearance required	0-018
	—
Insufficient clearance	-0-003
Pallet thickness recorded	0-100
	—
	0-097
	—
=Pallet thickness required	0-097

**CAUTION:** As a result of continued grinding, after prolonged service, the valves will protrude further into the cylinder head and may make it impossible to select a pallet thin enough to achieve the correct clearance, see DATA. Grinding of the valve tip to reduce the overall length of the valve is permissible provided that the valve tip still protrudes above the internal shoulder of the collar and that the selected pallet is proud of the collar top edge. Under no circumstances must the height of the valve collar be reduced otherwise an inadequate location for the pallet would result.

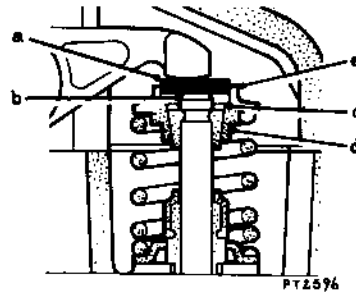

- a pallet
- b valve tip
- c internal shoulder
- d collar
- e collar top edge

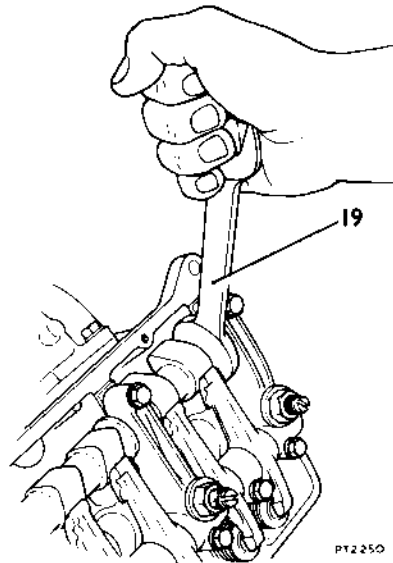

- 15 Fit the new pallets where required.
- 16 Fit the tappets to the inlet valves where the clearances have been adjusted.
- 17 Locate the camshaft in position on the cylinder head—do not connect to chain wheel.
- 18 Fit the rocker shaft assembly, see instructions 9 to 13, 12.29.54, ensuring that all the retaining bolts and cylinder head nuts are tightened to the correct torque.
- 19 Turn the camshaft by means of an open-ended spanner on the hexagon at the rear of the camshaft until No. 1 cylinder inlet valves are closed.
- 20 Check the valve clearances as described in instructions 3 to 6.
- 21 Turn the camshaft so that the timing mark on the flange is in line with the groove on the front bearing cap.
- 22 Turn the crankshaft FORWARD 90° so that the timing mark on the crankshaft pulley coincides with the zero on the timing cover scale.
- 23 Remove the distributor cap and check that the rotor arm points to the segment in the cap that feeds No. 1 cylinder spark plug. Refit the cap.
- 24 Secure the camshaft sprocket to the camshaft using a new lock plate, see instructions 17 to 20, 12.12.01.
- 25 Fit the spark plug tubes.
- 26 Fit the rocker cover, see 12.29.42.
- 26 Fit the camshaft cover, see 12.29.42.
- 28 Reconnect the battery.

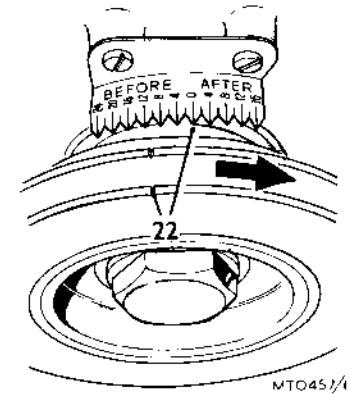
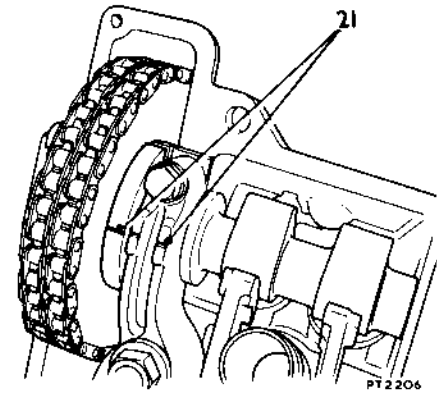

**DATA**

Inlet valve clearance . . . . .	0-018 in (0-46 mm)
Exhaust valve clearance . . . . .	0-018 in (0-46 mm)
Pallet thickness available . . . . .	0-90 in to 0-130 inch in increments of 0-001 inch

	0-018 in (0-46 mm)
	0-018 in (0-46 mm)
	0-90 in to 0-130 inch in increments of 0-001 inch

**ROCKER SHAFT ASSEMBLY**

Remove and refit

12.29.54

**Removing**

- 1 Disconnect the battery.
- 2 Drain the cooling system, see 26.10.01.
- 3 Remove the rocker cover, see 12.29.42.
- 4 Turn the engine over so that the timing mark on the camshaft flange is in line with the groove on the camshaft front bearing cap.
- 5 Remove the five cylinder head retaining nuts and washers.
- 6 Remove the ten bearing cap bolts.
- 7 Remove the four rocker shaft pedestal bolts.
- 8 Lift off the rocker shaft assembly.

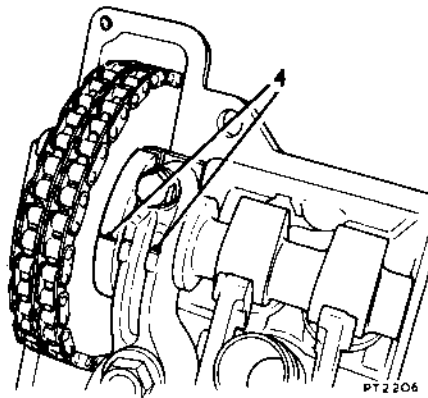
**Refitting**

- 9 Fit the rocker shaft assembly, locating it on the cylinder head retaining studs, and ten hollow dowels.
- 10 Fit the cylinder head retaining nuts and plain washers, leaving them loose.
- 11 Loosely fit the ten bearing cap bolts and spring washers.
- 12 Loosely fit the four rocker shaft pedestal bolts and spring washers.
- 13 Progressively tighten the five nuts and fourteen bolts to the correct torque figure, see 'TORQUE WRENCH SETTINGS', starting at the centre and working backwards.
- 14 Check, and if necessary adjust, the valve clearances, see 12.29.48.
- 15 Fit the rocker cover and connect the H.T. leads to the spark plugs.
- 16 Fill the cooling system, see 26.10.01.
- 17 Reconnect the battery.

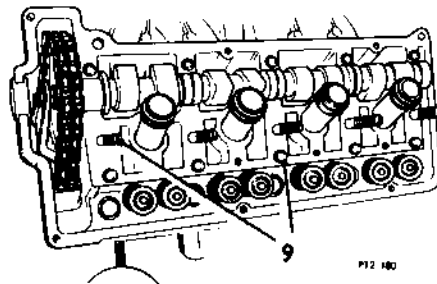
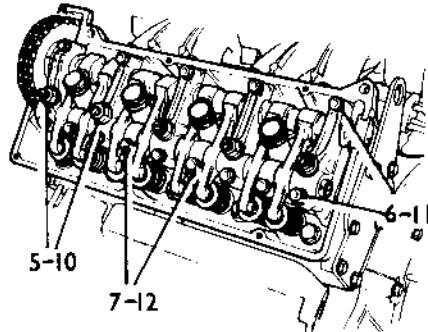
**ROCKER SHAFT ASSEMBLY**

Overhaul

12.29.55

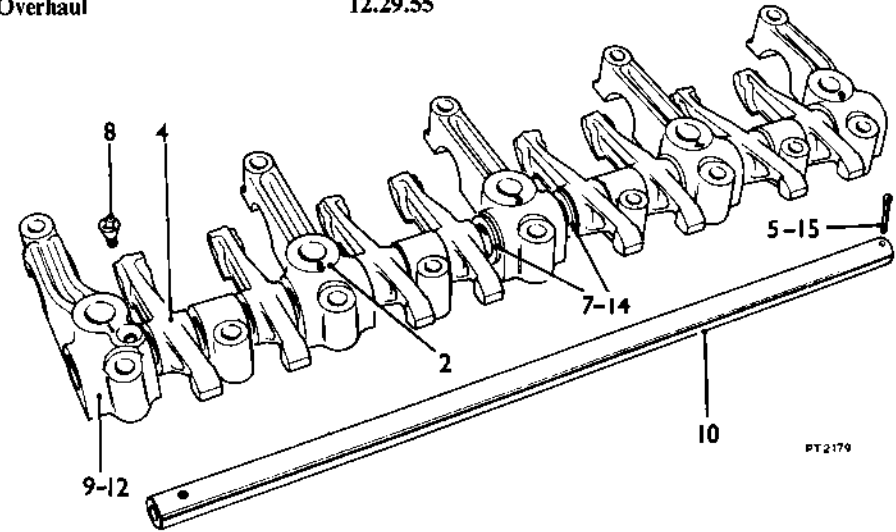

- 1 Remove the rocker shaft assembly, see 12.29.54.

**CAUTION:** It is important that, during the following instructions, the components are not mixed.

- 2 Check that the camshaft bearing caps are stamped '1' to '5', beginning at the chain drive end.
- 3 Check that the rocker shaft pedestals are stamped 'A' to 'D', beginning at the chain drive end.
- 4 Mark or stamp the rockers '1' to '8', starting at the chain drive end, if necessary.
- 5 Remove the split pin from the rocker shaft.
- 6 Remove the bearing caps, rockers and pedestals from the shaft.
- 7 Remove the spacers from both sides of No. 3 bearing cap.
- 8 Remove the locating screw from No. 1 bearing cap.
- 9 Remove No. 1 bearing cap from the rocker shaft.

**Examination**

- 10 Examine the rocker shaft for scores and pitting and check for wear, see DATA. Check that the oil-ways are clear.
- 11 Examine the rocker pads for wear and pitting and renew if unserviceable. Do not grind the pads as a method of restoration. Check the rocker bores for wear and renew if excessive.

**Reassembling**

**CAUTION:** Ensure that the blanking plug is not fitted too far into the rocker shaft, otherwise the oil feed may be obstructed.

- 12 Fit No. 1 bearing cap to the shaft and secure in position with the locating screw.
- 13 Assemble the remaining rockers, pedestals and bearing caps as illustrated.
- 14 Insert the two spacers each side of No. 3 bearing cap.
- 15 Fit the components to the shaft and secure the assembly with a new split pin.
- 16 Refit the rocker assembly, see 12.29.54.

**DATA**

Diameter of rocker shaft . . . . .	0.7482 to 0.7487 in (28.148 to 28.160 mm)
Length of shaft . . . . .	16.47 in (418.33 mm)
Internal diameter of rocker bore . . . . .	0.7492 to 0.7497 in (19.030 to 19.042 mm)

## TAPPETS — INLET VALVES

Remove and refit 12.29.57

### Removing

- 1 Disconnect the battery.
- 2 Drain the cooling system.
- 3 Remove the rocker cover, see 12.29.42.
- 4 Remove the rocker shaft assembly, see 12.29.54.
- 5 Remove the camshaft, see instructions 3 to 18, 12.13.02.
- 6 Lift out the tappets, identifying them for reassembly if they are to be refitted.  
**NOTE:** Sometimes the pallet adheres to the underside of the tappet and will be withdrawn as well. Ensure that the pallet is replaced in its correct position.

### Refitting

- 7 Ensure that eight pallets are in position on the valve assemblies.
- 8 Lubricate and fit the tappets squarely into their respective locations.
- 9 Refit the camshaft and rocker shaft assembly, see instructions 11 to 20, 12.13.02, omitting instruction 14.
- 10 Refit the rocker cover, see 12.29.42.
- 12 Reconnect the battery.

### NOTE:

Operations 12.29.64 to 12.29.77 are included under operation 12.29.19.

## SPARK PLUG TUBES

Remove and refit 12.29.81

### Removing

- 1 Remove the rocker cover, see 12.29.42.
- 2 Pull the tubes from their locations.

### Refitting

- 3 Clean the cylinder head location.
- 4 Smear the rubber seals at both ends of the tubes with rubber grease.
- 5 Insert the tubes into the cylinder head with the larger of the two seals uppermost.
- 6 Refit the rocker cover, see 12.29.42.

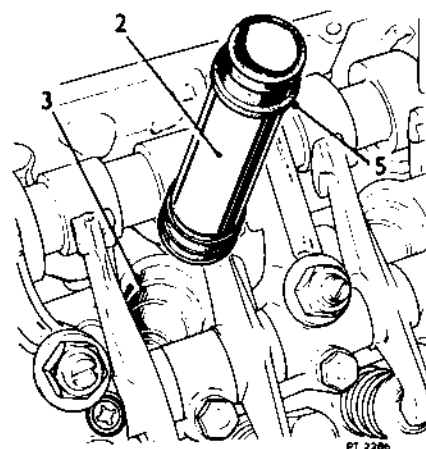
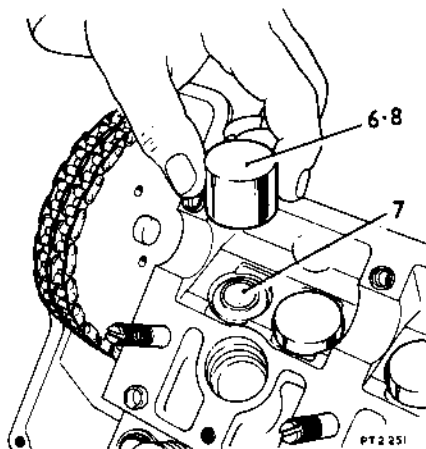

## ENGINE AND GEARBOX ASSEMBLY

Remove and refit 12.37.01

### Removing

- 1 Disconnect the battery.
- 2 Remove the bonnet, see 76.16.01.
- 3 Remove the fresh air duct.
- 4 Remove the radiator, see 26.40.01.
- 5 Disconnect, from the engine, the heater hoses.
- 6 Disconnect the overflow hose from thermostat housing.
- 7 Pull off the air intake hoses from the air cleaner.
- 8 Disconnect the brake servo hose from the engine.
- 9 Disconnect the oil pressure lead from the switch.
- 10 Disconnect the H.T. and L.T. leads from the distributor.
- 11 Disconnect the water temperature transmitter lead from the thermostat housing switch.
- 12 Disconnect the harness plug from the alternator.
- 13 Remove the fuel pipe from the pump inlet, and blank off the pipe and pump.
- 14 Disconnect the throttle cable.
- 15 Disconnect the mixture control cable.
- 16 Pull off the float chamber spill pipe from the rear carburetter.
- 17 Remove the bonnet lock, see 76.16.21.
- 18 Remove the exhaust front pipe, see 30.10.09.
- 19 Remove the gear lever, see 37.16.04.
- 20 Jack up the front of the car and lower onto axle stands.
- 21 Jack up the rear of the car and lower onto axle stands.
- 22 Mark the relationship of the propshaft to the gearbox drive flange and disconnect it from the gearbox.
- 23 Disconnect the two reverse light snap connectors.
- 24 Remove the speedometer cable from the gearbox.
- 25 Remove the clutch slave cylinder and move to one side.
- 26 Remove the engine L.H. mounting retaining nut.
- 28 Remove starter motor shield.
- 29 Remove the battery lead from the starter motor solenoid.

- 30 Disconnect the Lucar connector from the starter motor solenoid.
- 31 Remove the bolt securing the battery earth lead to the bell housing.
- 32 Remove the propshaft guard.
- 33 Lower the propshaft.
- 34 Fit slings to engine lifting hooks and hoist to take the weight of the engine.
- 35 Support the gearbox with a trolley jack.
- 36 Remove the four nuts retaining the rear mounting to the body.
- 37 Remove the R.H. engine mounting nut.
- 38 Lower the jack supporting the gearbox.
- 39 Hoist the engine and gearbox assembly and manoeuvre from the engine bay.

### Refitting

- 40 Fit slings to the engine lifting eyes, hoist engine and gearbox assembly and manoeuvre into the engine bay.
- 41 Place a trolley jack under the gearbox.
- 42 Lower the engine to line up the L.H. mounting with its sub-frame location.
- 43 Continue lowering, so that the engine R.H. rubber mounting stud locates in the slot in the body bracket.
- 44 Raise the gearbox and connect up the cross-member to the body locating studs.
- 45 Fit the nut and washer to the R.H. engine mounting stud.
- 46 Fit the nut and washer to the engine L.H. mounting stud.
- 47 Remove slings from engine lifting eyes.
- 48 Remove the jack from beneath gearbox.
- 49 Secure the propshaft to the gearbox, lining up the identification marks. Tighten the nuts to the correct torque, see 'TORQUE WRENCH SETTINGS'.
- 50 Fit the stabilizer (where fitted).
- 51 Fit the propshaft guard.
- 52 Secure R.H. harness to its retaining clip.
- 53 Connect the reverse light snap connectors.
- 54 Fit the clutch slave cylinder.
- 55 Secure the L.H. harness to its retaining clip.
- 56 Connect the negative earth lead from the battery to the bell housing.
- 57 Fit battery lead to starter motor solenoid.
- 58 Fit Lucar connector to the starter motor solenoid.
- 59 Fit the starter motor shield.

continued

- 60 Fit the speedometer cable to the gearbox.
- 61 Fit the exhaust front pipe, see 30.10.09.
- 62 Jack up rear of car and remove axle stands.
- 63 Jack up front of car and remove axle stands.
- 64 Fit and align the bonnet lock, see 76.16.21.
- 65 Fit spill pipe to the rear carburetter.
- 66 Fit the heater hoses to the engine connections.
- 67 Remove the blanking and fit the fuel pipe to the pump.
- 68 Fit the oil pressure warning light Lucar to the switch.
- 69 Connect the L.T. and H.T. leads to the distributor.
- 70 Connect the harness plug to the alternator.
- 71 Connect the coolant temperature transmitter lead.
- 72 Fit the vacuum hose to the engine.
- 73 Fit and adjust the throttle cable.
- 74 Fit the mixture control cable.
- 75 Fit the air intake hoses to the air cleaner.
- 76 Connect the overflow hose to the thermostat housing.
- 77 Fit the radiator, see 26.40.01.
- 78 Fit the fresh air duct.
- 79 Fit the bonnet, see 76.16.01.
- 80 Fit the gear lever, see 37.16.04.
- 81 Check the coolant level.
- 82 Check and if necessary top up the sump with oil of a recommended make and grade.
- 83 Check, and if necessary, top up the gearbox oil level — see **MAINTENANCE**.
- 84 Connect the battery.
- 85 Start the engine and run until normal operating temperature is reached whilst checking for coolant and oil leaks.
- 86 Check and adjust the ignition timing, see 86.35.15.
- 87 Check and if necessary tune and adjust the carburetters, see 19.15.02.
- 88 Road test the car.

## ENGINE ASSEMBLY

Strip and rebuild 12.41.05

Service tool: 38 U3 piston ring compressor

### Stripping

- 1 Remove the engine and gearbox assembly from the car, see 12.37.01, and drain the sump.
- 2 Remove the gearbox assembly from the engine.
- 3 Remove the exhaust manifold complete with the front pipe.
- 4 Remove the starter motor.
- 5 Remove the L.H. engine mounting complete with bracket.
- 6 Remove the alternator and adjusting link.
- 7 Remove the fan unit, see instructions 3 and 4, 26.25.21.
- 8 Remove the fan belt.
- 9 Remove the R.H. engine mounting complete with the bracket.
- 10 Disconnect the fuel pipe from the pump to the carburetters.
- 11 Disconnect the heater hose to the inlet manifold and water pump to heater hose.
- 12 Disconnect the engine breather pipe from the rocker cover.
- 13 Remove the ten bolts and lift off the inlet manifold complete with the carburetters and lift out the water pump to manifold connecting tube, see 26.30.25.
- 14 Remove the fuel pump.
- 15 Remove the distributor complete with the H.T. leads and location plate.
- 16 Remove the oil filter bowl and sealing ring.
- 17 Remove the oil pump.
- 18 Remove the hexagon drive shaft.
- 19 Remove the oil transfer adaptor with pressure switch.
- 20 Remove the dipstick.



- 21 Remove the clutch assembly.
- 22 Remove the eight bolts and spigot bush retaining plate, mark for reassembly the relationship of the flywheel hub to the crankshaft flange, and withdraw the flywheel.
- 23 Withdraw the six bolts and remove the rear adaptor plate.
- 24 Remove the rocker cover and gasket.

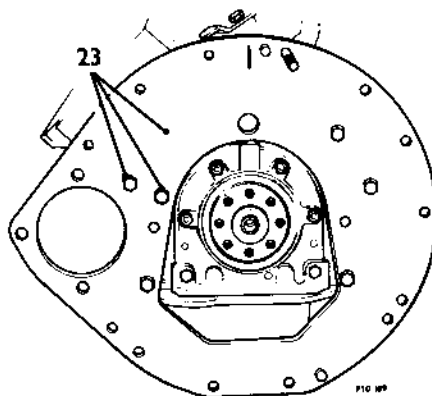
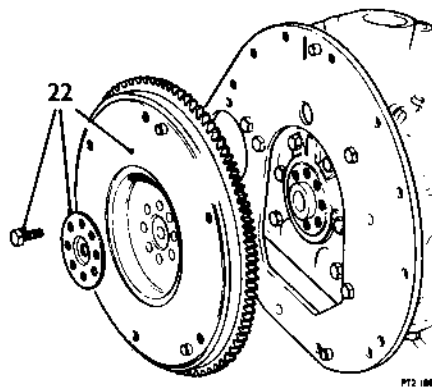

- 25 Turn the engine over to bring one of the camshaft sprocket retaining bolts to an accessible position. Unlock the washer and remove the bolt.
  - 26 Turn the engine over to expose the remaining bolt, and secure the camshaft sprocket to the support bracket. Unlock the washer and remove the bolt.
  - 27 Remove the five cylinder head retaining nuts and washers and remove the studs.
  - 28 Remove the five cylinder head retaining bolts and washers.
- CAUTION:** Release the cylinder head nuts and bolts in the reverse sequence to that shown in operation 12.29.27 to avoid distortion of the cylinder head.
- 29 Remove the two nuts and bolts securing the cylinder head to the timing cover.
  - 30 Lift off the cylinder head and remove the gasket.
  - 31 Remove the retaining bolt and washer and withdraw the crankshaft pulley.
  - 32 Position the engine on its side and remove the sump and oil pick-up pipe.
  - 33 Remove the twelve remaining bolts retaining the timing cover and withdraw the cover and gasket halves.

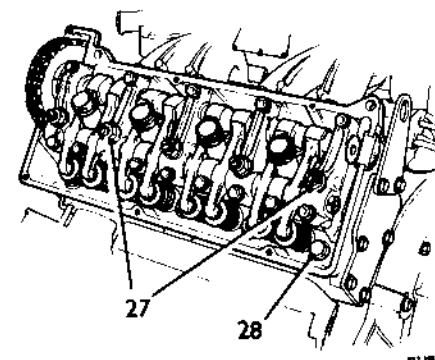
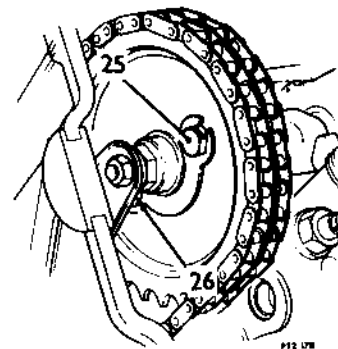

*continued*

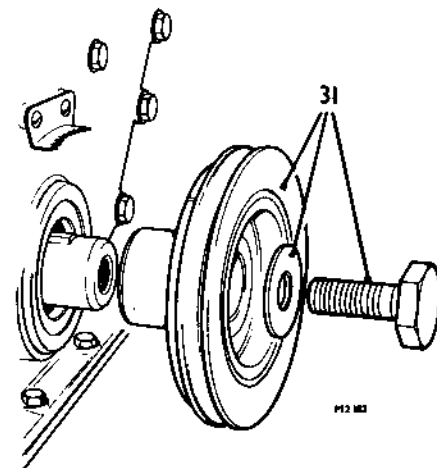
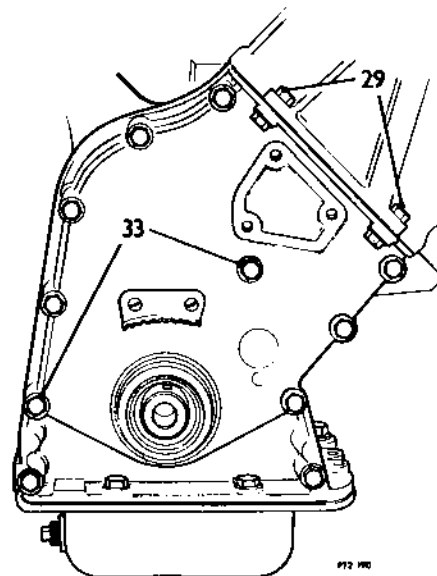

- 34 Remove the oil thrower.
- 35 Withdraw the two retaining bolts and remove the hydraulic timing chain tensioner.
- 36 Remove the three bolts securing:
  - a the adjustable guide
  - b the fixed guide
  - c the camshaft sprocket support bracket.
- 37 Remove the guides and support bracket complete with the camshaft sprocket and timing chain. Remove the sprocket from the bracket.
- 38 Remove the three bolts and lift off the water pump cover.
- 39 Turn the water pump impeller clockwise to release it from the jackshaft gear, and remove the assembly from the cylinder block.
- 40 Remove the engine lifting-eye.
- 41 Turn the jackshaft sprocket to expose the two Allen screws securing the keeper plate; remove the screws and withdraw the plate.

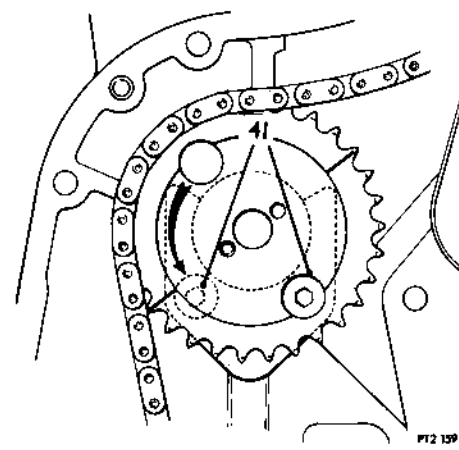
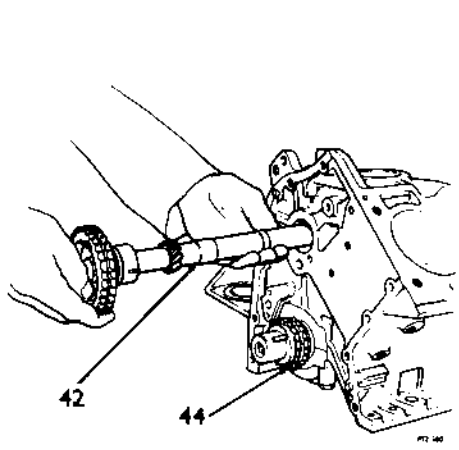
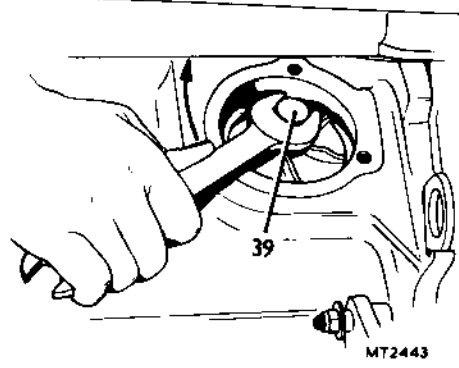
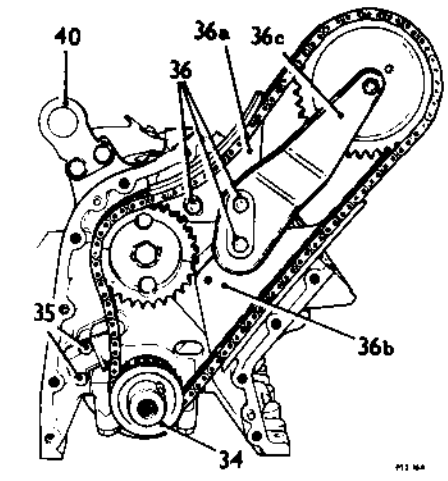

- 42 Withdraw the jackshaft complete with the sprocket from the cylinder block.
- 43 Unlock the tab washer and remove the bolt and sprocket from the jackshaft.
- 44 Withdraw the crankshaft sprocket.
- 45 Remove the drive key and shims from the crankshaft.
- 46 Remove the six bolts and withdraw the rear main oil seal and housing.
- 47 Remove the nuts securing Nos. 1 and 4 connecting rods, remove the caps and lower shells and withdraw the pistons and rods through the top of the bores.
- 48 Repeat instruction 47 on Nos. 2 and 3 connecting rods.
- 49 Remove the ten bolts securing the five main bearing caps and withdraw the caps complete with lower shells.
- 50 Lift out the crankshaft.
- 51 Remove the upper shells from the crankcase.
- 52 Remove the thrust washers from No. 3 main bearing.
- 53 Remove the spigot bush from the crankshaft.

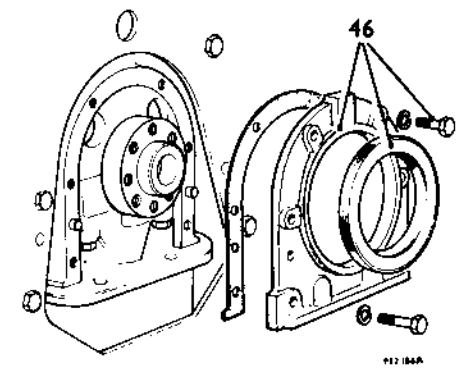
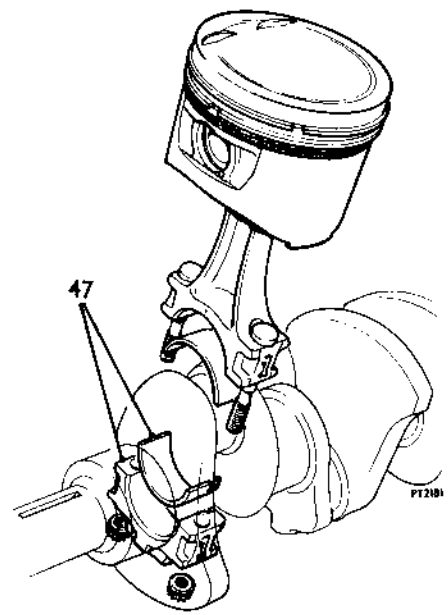
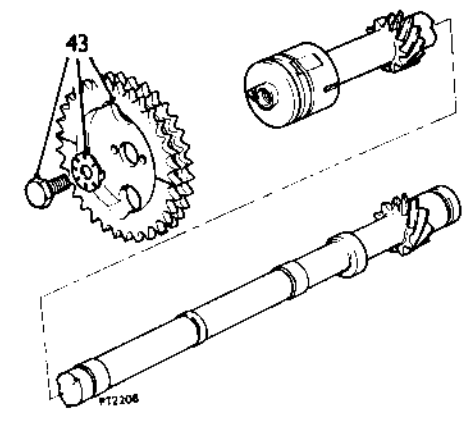

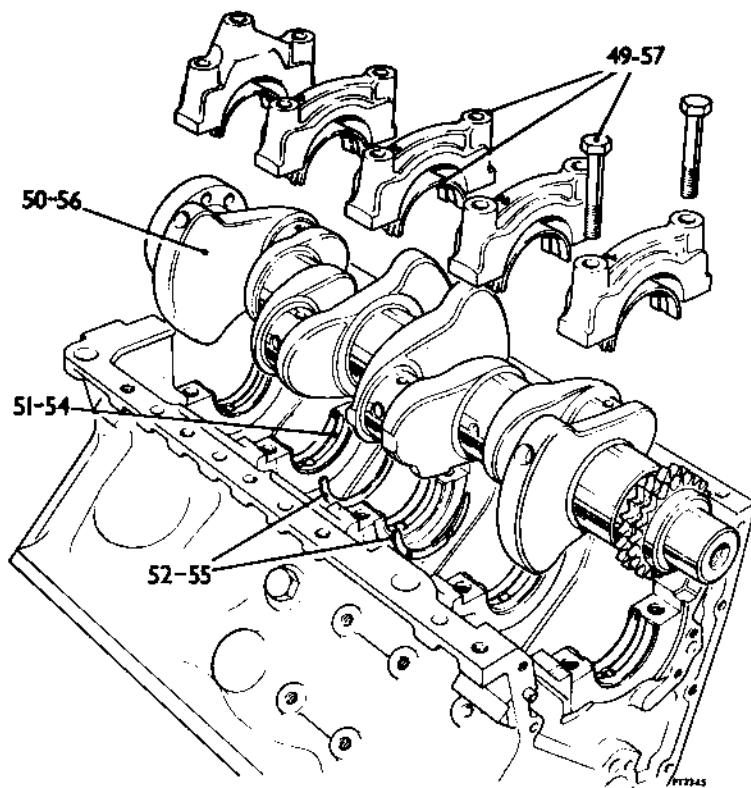
**Rebuilding**

**NOTE:** The following rebuilding instructions assume that all the individual components and assemblies have been examined, worn parts renewed and assemblies overhauled. Moreover, all joint faces are clean and parts lubricated before assembly.

- 54 Fit the five main bearing upper shells ensuring that the keeper tags locate in the recesses.
- 55 Fit the crankshaft thrust washers to No. 3 main bearing ensuring that the oil grooves face outwards.
- 56 Lower the crankshaft into the crankcase.
- 57 Fit the lower shells to the main bearing caps and fit them to the crankcase. Partially tighten the securing bolts.
- 58 Using either a dial gauge or feelers, check the crankshaft end-float, see DATA.

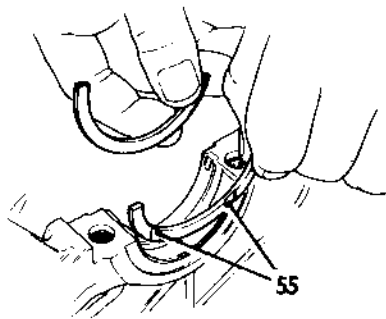

- 59 Tighten the main bearing cap bolts to the correct torque, see 'TORQUE WRENCH SETTINGS'.
- 60 Stagger the piston rings gaps, avoiding a gap on the thrust side, and compress the rings using special tool 38 U3.
- 61 Turn the crankshaft to position Nos. 2 and 3 crankpins at B.D.C. Insert the respective connecting rod and piston assemblies into the bores and tap the pistons home ensuring that the valve clearance indents in the piston crowns are fitted to the L.H. side of the engine.
- 62 Fit the upper bearing shells to the connecting rods, ensuring that the keeper tags locate in the recesses, and pull the connecting rods on to the journals.
- 63 Fit the lower shells to the connecting rod caps ensuring that the keeper tags locate in the recesses and fit them to the connecting rods. Tighten new nuts to the correct torque, see 'TORQUE WRENCH SETTINGS'.
- 64 Repeat instructions 60 to 63 on Nos. 1 and 4 pistons and connecting rod assemblies.

*continued*

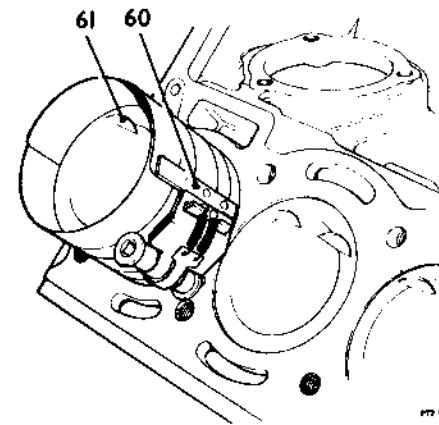
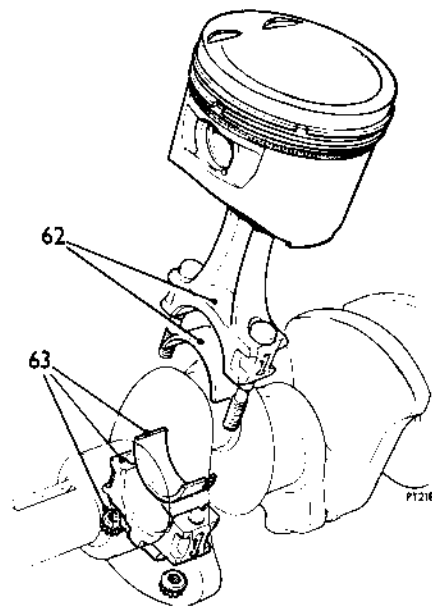
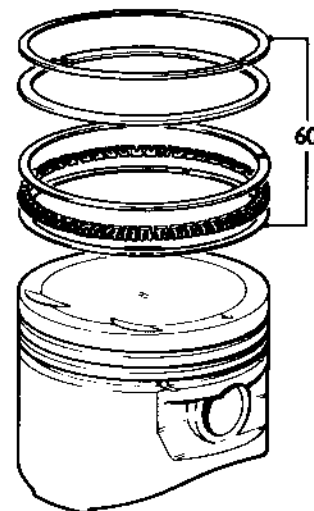
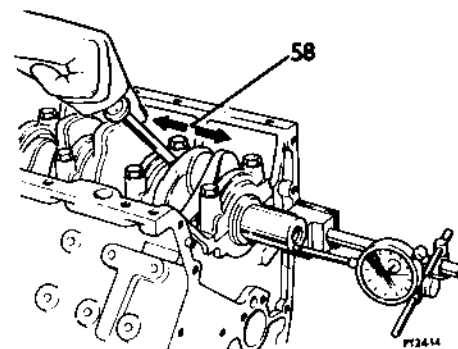

- 65 Fit a new seal to the rear main oil seal housing and using a new gasket and jointing compound, fit the housing locating it over the two dowels. Secure with the six bolts and spring washers noting that the two longer bolts are fitted at the bottom.
- 66 Fit the rear adaptor plate, locating it on two dowels.
- 67 Secure with the six bolts.
- 68 Fit the spigot bush.
- 69 Fit the flywheel, lining up the punch marks if the original flywheel or crankshaft is being refitted. Secure with the spigot bush retaining plate and eight bolts and tighten to the correct torque, see 'TORQUE WRENCH SETTINGS'.
- 70 Check the flywheel for run-out using a dial gauge, see DATA.
- 71 Fit the clutch driven and pressure plates, locating the pressure plate assembly over the three dowels.
- 72 Centralize the driven plate using a dummy primary shaft and evenly tighten the six bolts and spring washers to the correct torque.
- 73 Fit the sprocket to the jackshaft, locating it over the single dowel, and secure with the bolt and new lock washer.
- 74 Fit the jackshaft to the cylinder block, locate it with the keeper plate and secure the plate with the two Allen screws.
- 75 Fit the water pump impeller and cover assembly, checking the clearance as described in the refitting instructions 26.50.01.
- 76 Fit the distributor mounting plate.

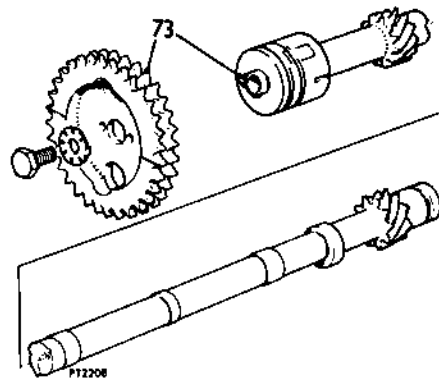
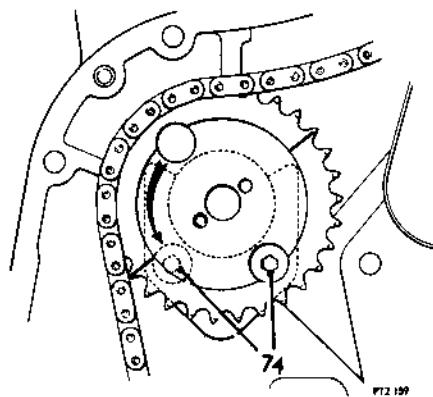
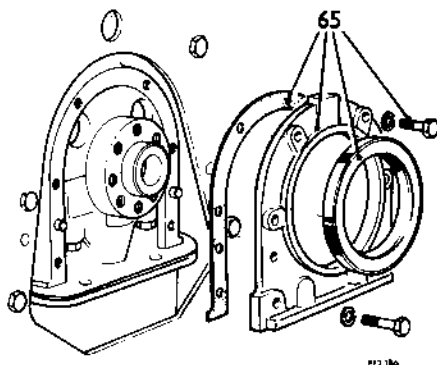

- 77 Fit the oil transfer adaptor complete with the oil pressure switch ensuring that a new 'O' ring is fitted and correctly located. Secure with the single bolt.
- 78 Fit two 'slave' guide studs to the bolt holes in the cylinder block to facilitate the fitting of the cylinder head and gasket.
- 79 Fit the cylinder head gasket locating it over the studs.
- 80 Fit the cylinder head, easing it over the guide studs.
- 81 Fit the five cylinder head studs.
- 82 Remove the two 'slave' studs and fit the five cylinder head retaining bolts and plain washers.
- 83 Fit the nuts and plain washers to the cylinder head studs.
- 84 Tighten the nuts and bolts to the correct torque and in the correct sequence, see 12.29.27.

**CAUTION:** Since no clearance exists between the valve heads and piston crowns once the cylinder head is fitted, care must be taken to ensure that the crankshaft is not allowed to turn a complete revolution until the valve timing has been completed otherwise damage to the valves and pistons will occur.

- 85 Temporarily fit the crankshaft sprocket and check its alignment with the jackshaft sprocket by placing a straight-edge across the two sprockets.

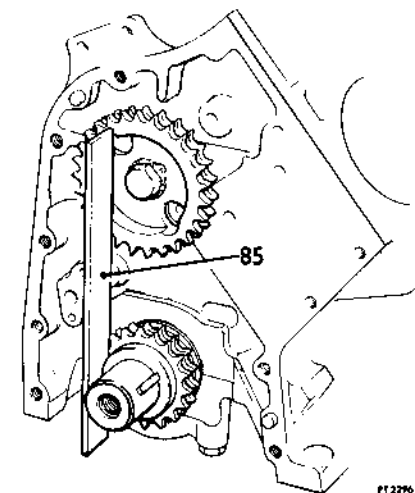
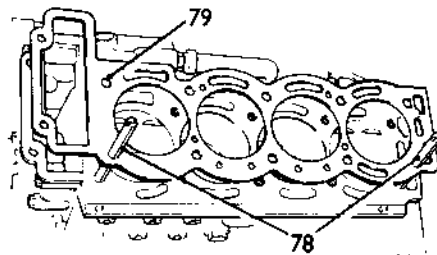
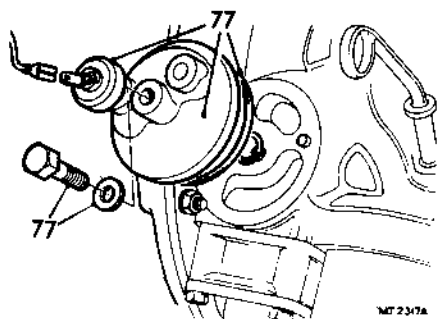

- 86 Adjust any misalignment by removing the crankshaft sprocket and fitting shims of suitable thickness between it and the crankshaft. Ensure that the sprocket is pushed fully home when checking the alignment.
- 87 Remove the sprocket, fit the crankshaft drive key and refit the sprocket.
- 88 Turn the camshaft until the timing mark on the flange is in line with the groove on the camshaft front bearing cap.
- 89 Temporarily locate the timing cover and crankshaft pulley and turn the crankshaft (having regard to the above caution) until Nos. 1 and 4 pistons are at T.D.C. Remove the pulley and timing cover.
- 90 Turn the jackshaft until the scribed line 'D' across the sprocket is equidistant between bolts 'B' and 'C' with the dowel to the left. Remove the pulley and timing cover.
- 91 Encircle the camshaft sprocket with the timing chain and insert through the cylinder head aperture. Locate the sprocket on the camshaft flange and secure with the lock-plate and one bolt. Do not bend over lock-plate tab at this stage.
- 92 Keeping the chain taut on the drive side fit the chain to the crankshaft and jackshaft sprockets. Check and if necessary make any adjustment to the position of the jackshaft sprocket to maintain it in its correct position as in instruction 90.
- 93 Fit and loosely secure the guides as follows:
  - a the adjustable guide
  - b the straight fixed guide
  - c the support bracket.

*continued*

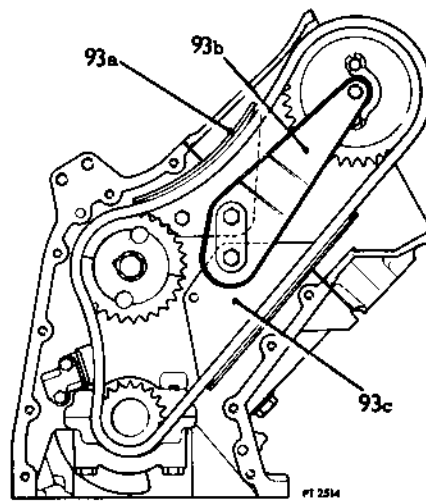
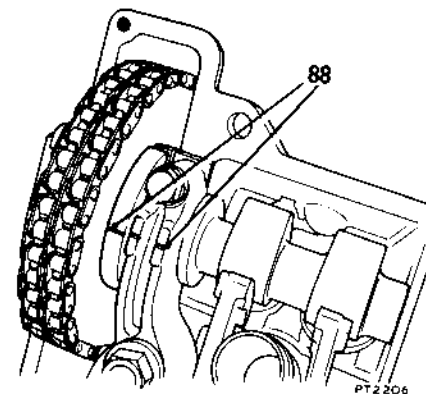
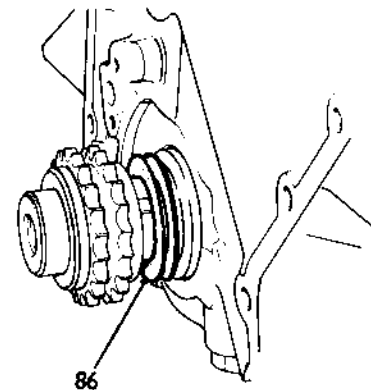

- 94 Fit a 'slave' bolt to the lower hole in the fixed guide to ensure alignment when fitting the timing cover centre bolt.
- 95 Fit the timing chain hydraulic tensioner and secure with the two bolts and spring washers, see 12.65.28.  
NOTE: To prevent the tensioner releasing while fitting, fit a spacer between the tensioner body and the back of the slipper.
- 96 Remove the spacer and insert a 0.100 in (2.54 mm) feeler gauge or slip gauge in its place, dimension 'A', see Note following instruction 35, 12.65.12.
- 97 Adjust the chain tension by applying pressure, in the direction of the arrow, to the adjustable guide while tightening the clamp bolt.
- 98 Remove the gauge and check that the scribed line on the jackshaft sprocket is still correctly positioned.
- 99 Tighten all the guide retaining bolts and remove the 'slave' bolt.
- 100 Turn the engine sufficiently to enable the remaining camshaft sprocket retaining bolt to be fitted. Tighten both bolts to the correct torque and bend over the lock-plate tabs. Refer to 12.13.01, instructions 17 and 18.
- 101 Check that the threaded spigot on the camshaft sprocket does not foul the support bracket.
- 102 Fit the oil thrower with the dished face outwards.
- 103 Using sealing compound, fit the two gasket halves to the cylinder block and locate the timing cover in position on the dowels. Evenly tighten the retaining bolts, ensuring that the centre bolt has a fibre washer under the head.
- 104 Fit the two nuts and bolts securing the cylinder head to the timing cover.

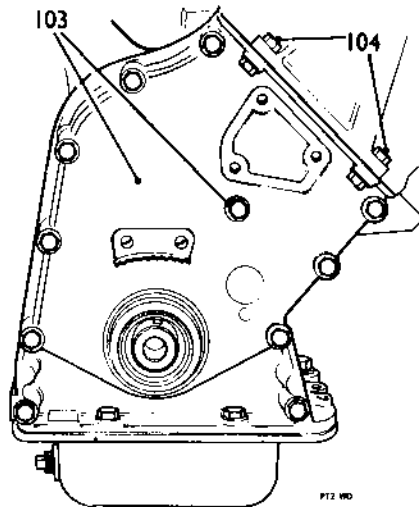
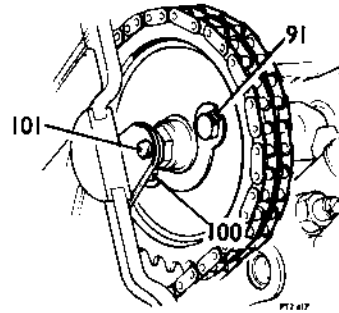
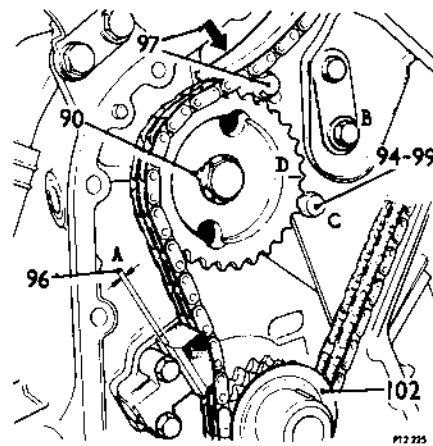

- 105 With the lip face leading, press in a new timing cover oil seal flush with the cover.
- 106 Fit the crankshaft pulley, securing it with the bolt and flat washer to the correct torque, see 'TORQUE WRENCH SETTINGS'.
- 107 Fit the engine front lifting eye.
- 108 Fit the semi-circular seals to the cylinder head.
- 109 Turn the engine over so that the timing mark on the camshaft flange is in line with the groove in the camshaft front bearing cap and the mark on the crankshaft pulley coincides with the zero mark on the timing cover scale.
- 110 Fit the rocker cover, using a new gasket, and secure with the six retaining screws.
- 111 Fit the distributor, see 86.35.20, instruction 10.
- 112 Fit the distributor cap and connect the H.T. leads to the spark plugs.
- 113 Fit the exhaust manifold complete with front pipe.
- 114 Fit the starter motor.
- 115 Fit the fan unit.
- 116 Fit the alternator and adjusting link.
- 117 Fit and adjust the fan belt.
- 118 Fit the fuel pump, using a new gasket.
- 119 Insert the hexagon drive shaft into the oil pump and fit the assembly and 'O' ring to the crankcase ensuring that the drive locates correctly into the distributor drive gear. Secure the pump with the four bolts and spring washers.
- 120 Fit the R.H. engine mounting.

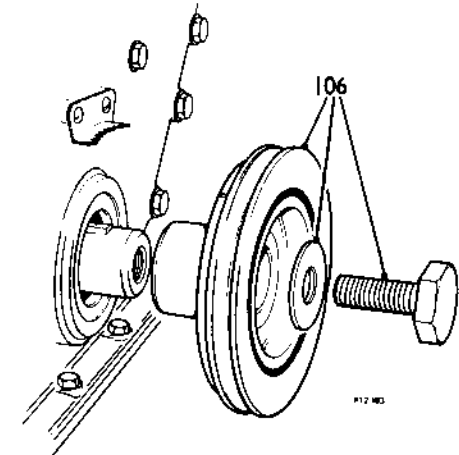
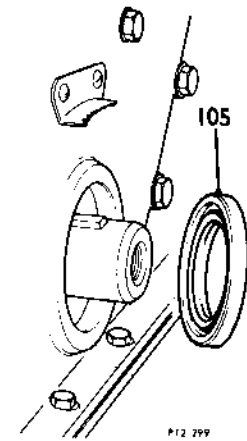

- 121 Fit the L.H. engine mounting.
- 122 Fit the oil strainer pipe, using a new gasket.
- 123 Fit the sump, using a new gasket.
- 124 Fit the oil filter assembly, ensuring that a new sealing ring is correctly located in the crankcase groove.
- 125 Insert the dipstick.
- 126 Place a new gasket in position on the cylinder head inlet ports and fit the inlet manifold complete with carburetters and air cleaner. Secure with the ten bolts, tightening evenly and to the correct torque.
- 127 Remove the thermostat housing cover and thermostat and insert the manifold to water pump connecting tube through the housing and press into position, see 26.30.25. Refit the thermostat and housing cover.
- 128 Connect the heater hose to the inlet manifold.
- 129 Connect the water pump to heater hose.
- 130 Connect the fuel pipe from the pump to the carburetters.
- 131 Connect the engine breather pipe to the rocker cover.
- 132 Refit the gearbox assembly to the engine.
- 133 Fit the engine and gearbox assembly to the car, see 12.37.01.
- 134 Fill the sump with the correct grade of oil to the 'high' mark on the dipstick.
- 135 Fill the cooling system.

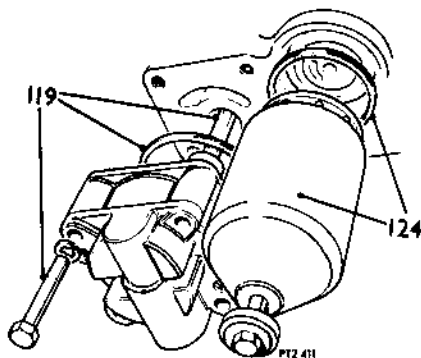

#### DATA

Crankshaft end-float . . . . .	0.003 to 0.011 in (0.07 to 0.28 mm)
Flywheel run-out maximum . . . . .	0.002 (0.050 mm) at a radius of 4 in (101 mm) on the friction face

#### ENGINE MOUNTING—FRONT L.H.

Remove and refit 12.45.01

##### Removing

- 1 Disconnect the battery.
- 2 Remove the fan guard.
- 3 Remove the fresh air duct, see 80.15.31.
- 4 Raise the car on a ramp.
- 5 Remove the single nut securing the engine mounting to the sub-frame.
- 6 Place a jack to support the engine, under the sump coupling plate.
- 7 Remove the engine R.H. mounting retaining nut.
- 8 Jack up the engine sufficiently to enable the L.H. rubber mounting to be unscrewed from the sump cross-member threaded hole.
- 9 Remove the mounting.
- 10 Remove the packing piece (where fitted).

##### Refitting

- 11 Screw the mounting into the sump cross-member, inserting the packing piece (where fitted).
- 12 Lower the jack and tighten the engine R.H. mounting nut.
- 13 Remove the jack and fit and tighten the single nut securing the L.H. engine mounting to the sub-frame.
- 14 Lower the ramp.
- 15 Fit the fan guard.
- 16 Fit the fresh air duct, see 80.15.31.
- 17 Connect the battery.

#### ENGINE MOUNTING—FRONT R.H.

Remove and refit 12.45.03

##### Removing

- 1 Disconnect the battery.
- 2 Support the weight of the engine under the sump coupling plate.
- 3 Remove the single nut securing the mounting to the body bracket.
- 4 Remove the two bolts retaining the rubber mounting to the engine bracket.
- 5 Withdraw the mounting.

##### Refitting

- 6 Fit the mounting to the engine bracket with the two bolts and spring washers.
- 7 Secure the mounting to the body bracket with the single nut and plain washer.
- 8 Remove the engine support.
- 9 Connect the battery.

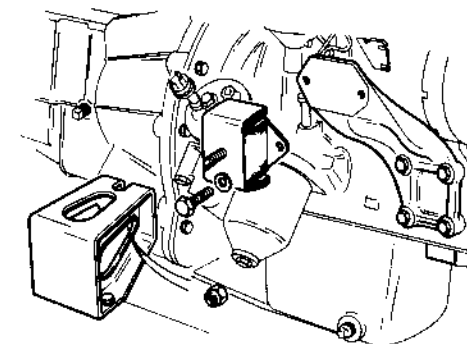

A12-98

**ENGINE MOUNTING—REAR CENTRE****Remove and refit** 12.45.08**Removing**

- 1 Drive the car onto a ramp and disconnect the battery.
- 2 Raise the ramp and place a jack in support under the gearbox.
- 3 Disconnect the restraint cable from the cross-member.
- 4 Remove the two nuts securing the mounting assembly to the gearbox extension.
- 5 Remove the four bolts retaining the mounting cross-member to the body and remove the assembly from the car, complete with the tie-bar.
- 6 Remove the centre bolt.
- 7 Remove the restrictor plate.
- 8 Remove the two nuts and bolts securing the rubber mounting to the cross-member.

**Refitting**

- 9 Fit the rubber mounting to the cross-member with the two nuts and bolts.
- 10 Reverse instructions 6 to 8, leaving the centre bolt slack.
- 11 Fit the cross-member to the body with the four nuts.
- 12 Fit the assembly to the gearbox extension with the two nuts.
- 13 Tighten the centre bolt.
- 14 Connect and adjust the restraint cable, see 37.20.01, instruction 29.
- 15 Remove the jack, lower the car and connect the battery.

**ENGINE REAR ADAPTOR PLATE****Remove and refit** 12.53.03**Removing**

- 1 Remove the gearbox, see 37.20.01.
- 2 Remove the starter motor, see 86.60.01.
- 3 Remove the clutch assembly, see 33.10.01.
- 4 Remove the flywheel, see instructions 4 to 6, 12.53.07.
- 5 Remove the six bolts securing the adaptor plate to the cylinder block.
- 6 Remove the plate from the two dowels and one stud location.

**Refitting**

- 7 Clean the engine and adaptor plate mating faces and locate the plate in position on the two dowels and stud.
- 8 Secure the plate with the six bolts.
- 9 Fit the flywheel, see instructions 7 and 8, 12.53.07.
- 10 Fit the clutch, see 33.10.01.
- 11 Fit the starter motor, see 86.60.01.
- 12 Fit the gearbox, see 37.20.01.

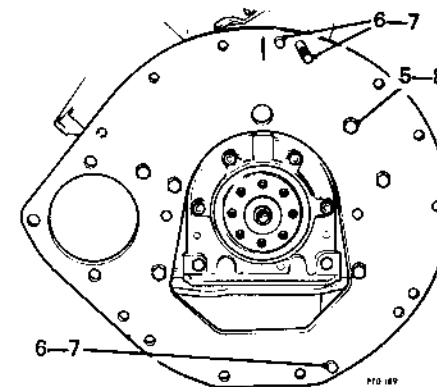



## FLYWHEEL

Remove and refit

12.53.07

### Removing

- 1 Isolate the battery.
- 2 Remove the gearbox, see 37.20.01.
- 3 Remove the clutch assembly, see 33.10.01.
- 4 Remove the eight bolts and spigot bush retaining plate securing the flywheel to the crankshaft.
- 5 Mark for reassembly the relationship between the flywheel hub and the crankshaft flange.
- 6 Withdraw the flywheel and ring gear assembly.

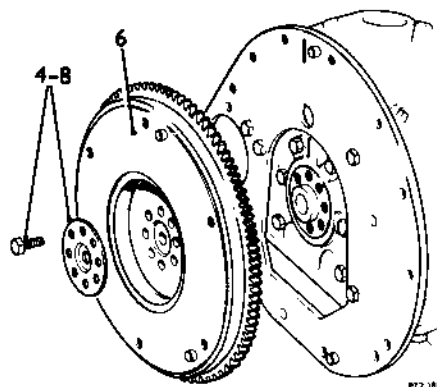

### Refitting

- 7 Locate the flywheel assembly on the crankshaft spigot so that the identification marks line up.
- 8 Secure the flywheel to the crankshaft with the eight bolts and retaining plate. Tighten the bolts to the correct torque, see 'TORQUE WRENCH SETTINGS'.
- 9 If a new flywheel has been fitted, turn the engine over so that Nos. 1 and 4 pistons are at T.D.C. with No. 1 cylinder firing.
- 10 Make a chisel mark on the outside edge of the flywheel in line with the vertical mark on the engine rear adaptor plate.
- 11 Using a dial gauge, check the flywheel for run-out, see DATA.
- 12 Refit the clutch, see 33.10.01.
- 13 Refit the gearbox, see 37.20.01.
- 14 Reconnect the battery.

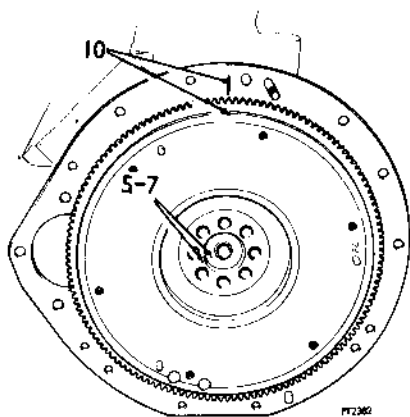

## DATA

Flywheel run-out maximum . . . . .

0.002 (0.050 mm) at a radius of 4 in (101 mm) on the friction face.

## STARTER RING GEAR

Remove and refit

12.53.19

### Removing

- 1 Remove the flywheel, see 12.53.07.
- 2 Drill a hole approximately 0.375 in (10 mm) between the root of any tooth and the inner rim of the ring gear. Drill sufficiently to weaken the starter ring without drilling the flywheel.
- 3 Secure the flywheel in a soft-jawed vice.
- 4 Place a heavy cloth over the ring gear for protection against flying fragments. **WARNING:** Take adequate precautions to avoid injury from flying fragments when splitting the ring gear.
- 5 Place a chisel immediately above the drilled hole and strike sharply to split the ring gear.

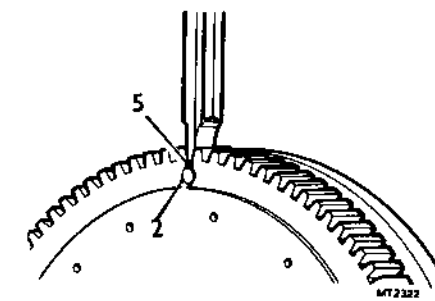

### Refitting

- 6 Place the flywheel, flanged side down, on a flat surface.
- 7 Heat the starter ring uniformly to between 170 to 175°C (338 to 347°F); do not exceed this temperature.
- 8 Locate the ring gear in position, and retain in position until it contracts sufficiently to grip the flywheel.
- 9 Allow the starter ring to cool gradually to avoid stress distortion. A maximum permissible gap of 0.025 in (0.6 mm) is allowed between the flywheel and starter ring on one length of 6 in (15 cm) only.
- 10 Fit the flywheel, see 12.53.07.

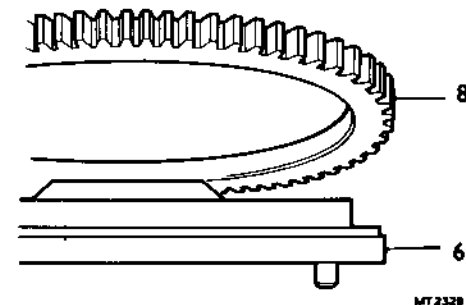

## OIL FILTER ASSEMBLY

Element — remove and refit — instructions 1 to 5 and 10 to 13 12.60.02

Overhaul — instructions 6 to 9 12.60.08

### Removing

- 1 Drive the car onto a ramp and isolate the battery.
- 2 Raise the ramp.
- 3 Place a suitable receptacle under the filter bowl to catch surplus oil.
- 4 Remove the filter bowl centre retaining bolt and withdraw the assembly, complete with element.

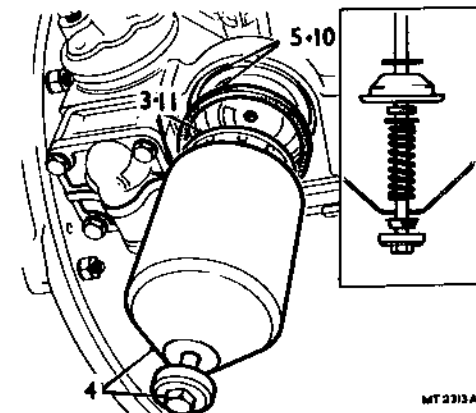

continued

- 5 Extract the seal from the annular groove in the crankcase.

#### Overhauling

- 6 Remove the element and discard it.  
7 Dismantle the centre bolt assembly and clean all components including the bowl.  
8 Assemble the centre bolt assembly to the bowl as illustrated, using new seals. If necessary, renew the spring.  
9 Secure the assembly with the retaining clip ensuring that it locates properly in the annular groove in the centre bolt.

#### Refitting

- 10 Clean the crankcase mating face and fit a new seal to the annular groove.  
11 Insert a new paper element into the filter bowl and secure the assembly to the crankcase and whilst tightening the centre bolt rotate the bowl to ensure that it seats correctly in the groove. Tighten to 20 lbf ft (2.8 kgf m).  
12 Reconnect the battery, start the engine and check for oil leaks from the filter assembly.  
13 Lower the ramp, check the oil level in the sump and top up if necessary.

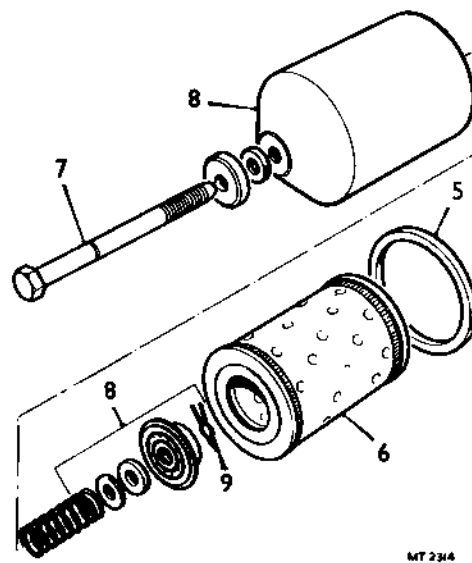

MT 234A

### OIL TRANSFER HOUSING

#### Remove and refit

12.60.14

#### Removing

- 1 Disconnect the electrical cable from the pressure warning switch.  
2 Remove the centre retaining bolt and withdraw the transfer housing.  
3 Remove the 'O' ring seals from the transfer housing.

#### Refitting

- 4 Clean the housing and fit new 'O' ring seals.  
5 Refit the housing, engaging the dowel in the cylinder block with the locating hole in the housing.  
6 Refit and tighten the centre retaining bolt to the correct torque, see 'TORQUE WRENCH SETTINGS'.  
7 Re-connect the cable to the pressure warning light switch.

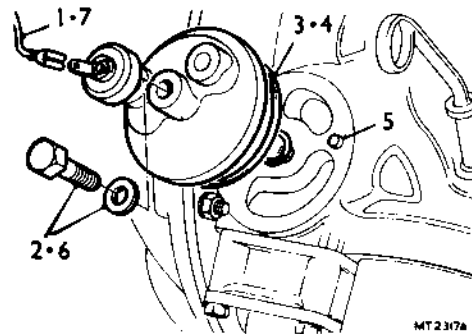

MT 237A

### OIL PICK-UP STRAINER

#### Remove and refit

12.60.20

#### Removing

- 1 Drive the car onto a ramp.  
2 Isolate the battery.  
3 Drain the sump.  
4 Remove the sump retaining nuts, bolts and washers.  
5 Lower the sump sufficiently to expose the mounting flange of the oil strainer.  
6 Remove the two bolts and plain washers securing the oil strainer to the crankcase.  
7 Withdraw the oil pick-up strainer complete.  
8 Remove the gasket.

#### Refitting

- 9 Clean the crankcase and oil pick-up strainer flange mating faces.  
10 Fit a new gasket.  
11 Fit the oil strainer to the crankcase, securing with the two bolts and plain washers.  
12 Refit the sump, see instruction 15, 12.60.44.  
13 Refill the sump to the 'high' mark on the dipstick with a recommended grade of oil.  
14 Lower the car and reconnect the battery.

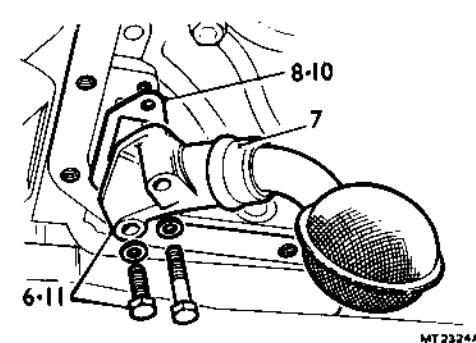

MT 2324A

### OIL PUMP

#### Remove and refit

12.60.26

#### Remove

- 1 Isolate the battery.  
2 Raise the car on a ramp.  
3 Disconnect the engine stabilizer from the manifold bracket.  
4 Remove the R.H. engine mounting to sub-frame bolts.  
5 Jack up the engine on the R.H. side and raise it approximately 1 1/4 in (32 mm).  
6 Remove the oil filter, see 12.60.02.  
7 Remove the four bolts and spring washers securing the oil pump to the engine.  
8 Withdraw the pump complete with drive shaft.

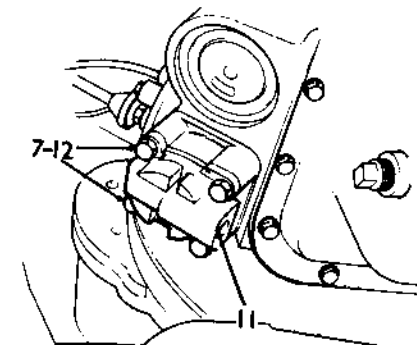

P12 294

### Refitting

- 9 Clean the pump and crankcase mating faces and check that the 'O' ring is in position and in sound condition.
- 10 Insert the pump drive shaft so that it locates fully into the distributor drive gear.
- 11 Offer up the pump to the crankcase so that the pressure relief valve is towards the crankcase.
- 12 Secure in position with the four bolts and spring washers.
- 13 Refit the oil filter.
- 14 Lower the engine and secure the engine mounting to the sub-frame location and remove the jack.
- 15 Reverse instructions 1 to 3.
- 16 Check the level of oil in the sump and replenish if necessary.

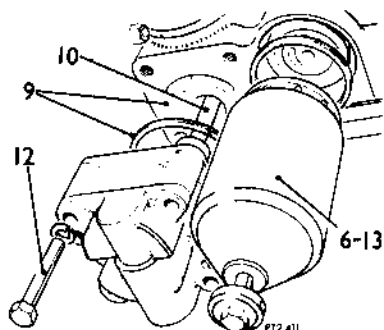

## OIL PUMP

### Overhaul

12.60.32

### Dismantling

- 1 Remove the oil pump, see 12.60.26.
- 2 Withdraw the hexagonal drive shaft.
- 3 Remove the two screws and lift off the pump cover from the pump body.
- 4 Remove the rotors.
- 5 Remove the 'O' sealing ring from the pump body.
- 6 Remove the split pin from the pump oil pump cover.
- 7 Remove the locating plug, spring and relief valve.
- 8 Remove the 'O' sealing ring from the locating plug.

### Inspection

- 9 Clean all components.
- 10 Install the rotors in the pump body, ensuring that the chamfered edge of the outer rotor is at the driving end of the rotor pocket.

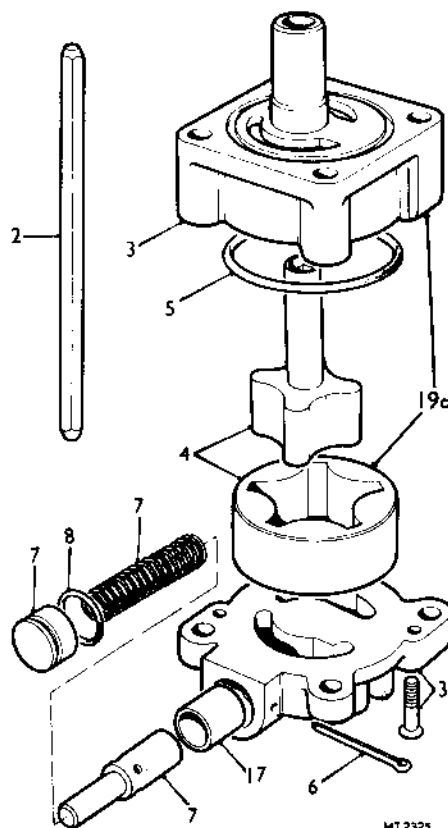

- 11 Check the end-float of the inner and outer ring.
- 12 Check the outer ring to pump body diametrical clearance.
- 13 Check the rotor lobe clearances.
- 14 Check the length of the relief valve spring.
- 15 Check the relief valve and its bore for scoring or damage.
- 16 Renew the pump assembly if the clearances or end-floats measured in operations 11 to 13 exceed the figures given in DATA.
- 17 Check the bush in the pump cover, renew if scored or worn.

### Reassembling

- 18 Lubricate all parts in clean engine oil before assembling.
- 19 Reverse the procedure in 1 to 8, noting:
  - a Fit the relief valve with its large diameter first, so that its small spigot will engage with the spring.
  - b Fit a new 'O' sealing ring to the oil pressure relief valve locating plug.
  - c Ensure that the outer rotor is installed in the pump body with its chamfered edge towards the driving end.
  - d Fit a new 'O' sealing ring to the pump body.
- 20 Check the pump for freedom of action.
- 21 Fit the oil pump, see 12.60.26.

### DATA

#### Oil pump

Outer ring end-float	0.004 in (0.1 mm)
Inner ring end-float	0.004 in (0.1 mm)
Outer ring to pump body diametrical clearance	0.008 in (0.2 mm)
Rotor lobe clearance	0.010 in (0.25 mm)

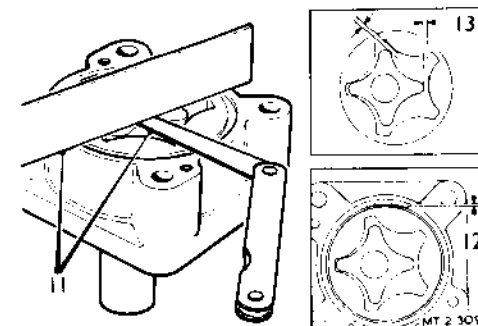

**OIL SUMP**

Remove and refit

12.60.44

**Removing**

- 1 Raise the car on a ramp.
- 2 Drain the sump.
- 3 Remove the bolts, washers and nuts securing the sump to the crankcase. The locations of these bolts, washers and nuts are illustrated. Note that there is an aperture at the front of the flywheel. Ensure when removing the rear sump bolts that they do not fall into the bell housing.
- 4 Lower the sump to expose the mounting flange of the oil strainer.
- 5 Remove the two bolts and plain washers securing the oil strainer flange to the crankcase.
- 6 Withdraw the oil strainer.
- 7 Rotate the sump 90°.
- 8 Withdraw the sump and gasket.

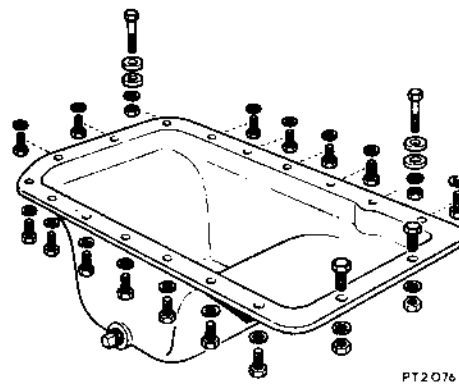
**Refitting**

- 9 Ensure that the sump flange and crankcase are clean.
- 10 Smear the sump gasket with grease and fit it to the crankcase.
- 11 Ensure that the crankcase and oil strainer flange are clean.
- 12 Offer up the sump to the engine 90° out of position.
- 13 Rotate sump 90° to bring it to its fitted position but do not offer up to crankcase.
- 14 Renew the sump strainer flange gasket and fit the strainer to the crankcase. Secure with two bolts, and plain washers.
- 15 Offer up the sump to the crankcase and secure with bolts and nuts as illustrated.
- 16 Lower the car.
- 17 Refill the sump.

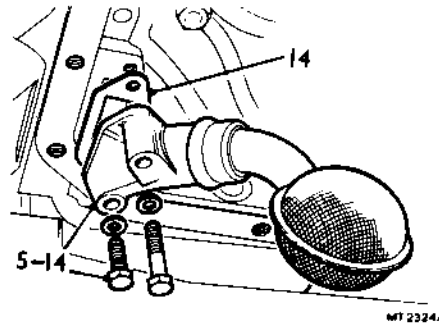
**OIL PRESSURE RELIEF VALVE**

Remove and refit

12.60.56

**Removing**

- 1 Remove the oil pump, see 12.60.26.
- 2 Withdraw the hexagonal drive shaft.
- 3 Remove the split pin from the oil pump casing.
- 4 Remove the locating plug, spring and plunger by tapping the pump cover. NOTE: Since in some instances the 'O' ring on the locating plug may stick to the bore, in order to accomplish instruction 4 the pump cover will have to be removed and the plug tapped out from the underside of the cover. Follow instructions 5 and 6 if this is necessary.
- 5 Remove the two screws securing the pump cover to the main body and lift off the cover.
- 6 Using a suitable soft drift tap out the plug from the underside of the pump cover.
- 7 Remove the 'O' ring from the locating plug.

**Examination**

- 8 Examine the plunger and its bore for scores or wear.
- 9 Check the plunger spring length and renew if not in accordance with DATA.

**Refitting**

- 10 Observing absolute cleanliness, fit the plunger to the pump cover ensuring that it moves freely in its bore.
- 11 Fit the spring over the plunger spigot end noting that the close coiled end is inserted first.
- 12 Fit a new 'O' ring to the locating plug and insert the plug.
- 13 Fit a new split pin.
- 14 Fit the cover to the pump and secure with the two screws.
- 15 Fit the hexagonal shaft to the crankcase.
- 16 Refit the oil pump to the engine, see 12.60.26.

**DATA**

Relief valve spring free length . . . . . 1.70 in (43.18 mm)

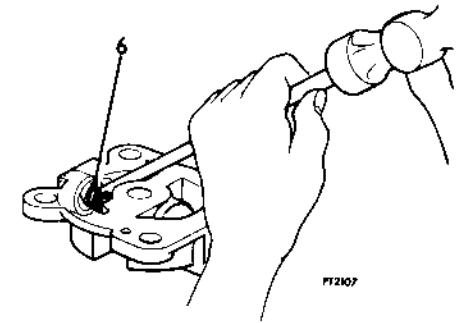
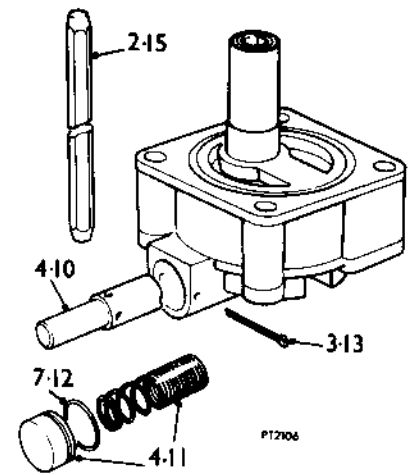

## TIMING CHAIN COVER

Remove and refit

12.65.01

### Removing

- 1 Isolate the battery.
- 2 Remove the fan unit, see 26.25.06.
- 3 Remove the alternator, see 86.10.02.
- 4 Remove the two cylinder head to timing cover nuts and bolts.
- 5 Remove the two front sump nuts and bolts.
- 6 Slacken the first four sump bolts both sides of the sump.  
**CAUTION:** Cover the access to the sump to prevent objects falling into the sump.
- 7 Remove the crankshaft pulley retaining bolt and washer and withdraw the pulley.
- 8 Remove the ten bolts securing the timing cover to the cylinder block.
- 10 Remove the alternator adjusting link.  
**NOTE:** There are four different lengths of bolts used to attach the timing cover. To facilitate refitting, keep the bolts in their respective holes in the cover.
- 10 Withdraw the timing cover and the two halves of the gasket.

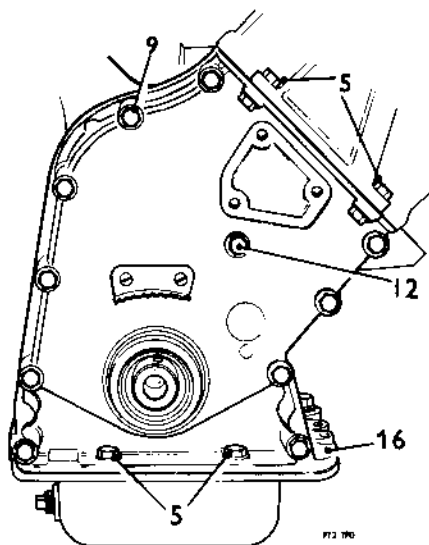

### Refitting

- 12 Clean the timing cover and cylinder block mating faces, ensuring that all traces of old gasket and sealing compound are removed.
- 12 Apply sealing compound to both sides of the gasket halves and fit the timing cover. Secure in position with the ten bolts, ensuring that the centre bolt has a fibre washer under the head. Fit the alternator adjusting link.
- 13 Refit the crankshaft pulley and secure with the special retaining bolt and plain washer.
- 14 Refit the two front sump bolts and tighten the eight slackened sump bolts (four each side).
- 15 Fit and tighten the two cylinder head to timing cover nuts and bolts.
- 16 Reverse instructions 1 to 3.

## TIMING COVER OIL SEAL

Remove and refit

12.65.05

### Removing

- 1 Disconnect the battery.
- 2 Slacken the alternator adjustment.
- 3 Remove the fan belt.
- 4 Remove the fan unit, see instructions 3 and 4, 26.25.21.
- 5 Remove the crankshaft pulley retaining bolt and plain washer.
- 6 Withdraw the crankshaft pulley.
- 7 Remove the oil seal taking care not to damage the timing cover.

### Refitting

- 8 Grease a new oil seal and with the lip face leading, tap the seal into the timing cover location until flush with the cover.  
**NOTE:** Later-type oil seals are dual lipped.
- 9 Refit the crankshaft pulley securing with the bolt and washer and tighten to the correct torque.
- 10 Reverse instructions 1 to 4.

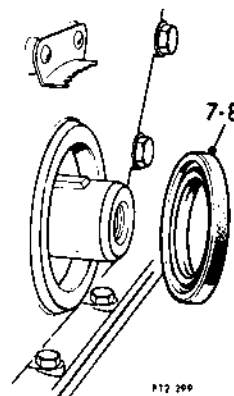
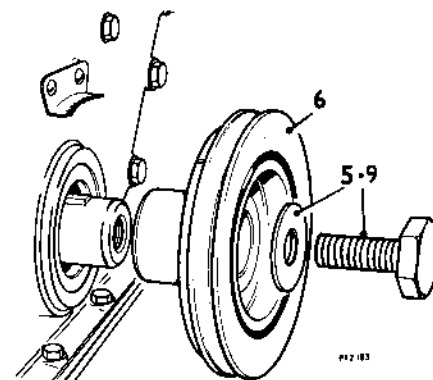

## VALVE TIMING

Check and adjust

12.65.08

### Checking

- 1 Disconnect the battery.
- 2 Turn the engine over until the timing mark on the crankshaft pulley coincides with the zero mark on the timing cover scale.
- 3 Remove the distributor cap and check that the rotor arm points to the segment in the cap for No. 1 cylinder.
- 4 Remove the camshaft rocker cover, see 12.29.42.
- 5 The valve timing is correct when the timing mark on the camshaft flange is in line with the corresponding groove on the camshaft front bearing cap.

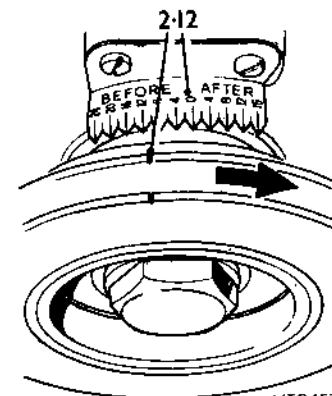

continued

MTO457

- 6 Refit the distributor cap.
- 7 Refit the camshaft cover, see 12.29.42.
- 8 Reconnect the battery.

**Adjusting**

- 9 Remove the camshaft cover, see 12.29.42.
- 10 Turn the engine over so that the timing mark on the camshaft flange is 180° distant from the groove on the camshaft front bearing cap.
- 11 Unlock and remove the exposed bolt securing the camshaft sprocket to the camshaft.
- 12 Remove the timing chain cover, see 12.65.01.  
**NOTE:** Before actually withdrawing the pulley and removing the cover, turn the engine over so that the timing mark on the crankshaft pulley is in line with the zero mark on the cover scale.
- 13 Remove the distributor cap and check that the rotor arm points to the segment in the cap that feeds No. 1 cylinder. Refit the cap.
- 14 Remove the timing cover and pulley.
- 15 Using a 'slave' nut secure the camshaft sprocket to the support bracket.
- 16 Unlock and remove the remaining bolt and lock washer securing the camshaft sprocket.
- 17 Remove the timing chain tensioner, see instructions 2 to 4, 12.65.28.
- 18 Slacken off the two bolts securing the adjustable guide.
- 19 Turn the camshaft until the timing mark on the flange is in line with the groove on the front bearing cap.
- 20 Release the camshaft sprocket from the support bracket, make the necessary adjustment, and whilst keeping the chain taut on the drive side secure the camshaft sprocket to the camshaft flange with one bolt and a new lock washer.  
**NOTE:** Whilst carrying out the above instruction ensure that the position of the jackshaft sprocket does not alter, i.e. the scribe line remains horizontal as described and illustrated in operation 12.65.12, instruction 28.
- 21 Fit the timing chain tensioner, see instructions 11 to 15, 12.65.28.

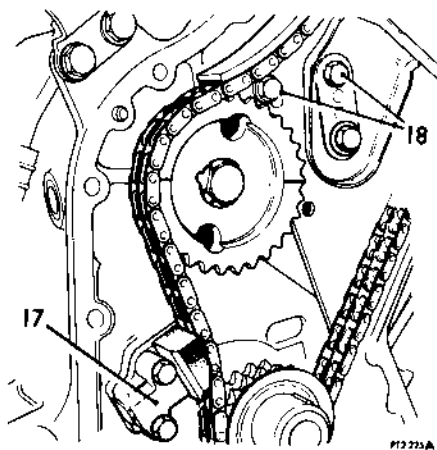
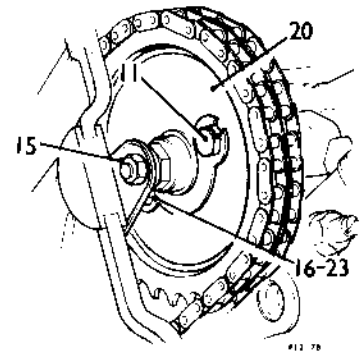
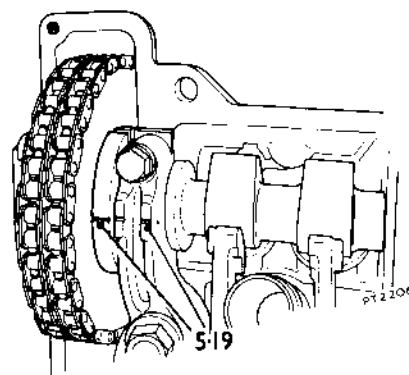

- 22 Fit the timing chain cover, see instructions 12 to 17, 12.65.01, leaving the battery disconnected.
- 23 Turn the engine over sufficiently to enable the remaining camshaft sprocket retaining bolt to be fitted and locked.
- 24 Fit the camshaft cover, see 12.29.42.
- 25 Re-connect the battery.

**DATA**

**Valve timing**

Inlet valves open . . . . .	14° B.T.D.C.
Close . . . . .	50° A.B.D.C.
Exhaust valves open . . . . .	50° B.B.D.C.
Close . . . . .	14° A.T.D.C.

**TIMING CHAIN AND SPROCKETS**

<b>Remove and refit</b>	<b>12.65.12</b>
<b>Timing chain</b>	<b>12.65.14</b>
which includes	
<b>Guides</b>	<b>12.65.50</b>

**Removing**

- 1 Remove the bonnet.
- 2 Disconnect the battery.
- 3 Remove the camshaft cover, see 12.29.42.
- 4 Remove the timing chain cover, see 12.65.01.
- 5 Turn the engine over so that the timing mark on the camshaft flange is at the bottom, i.e. 180° distant from the corresponding timing groove in the camshaft front bearing cap. This is necessary to enable the bottom bolt securing the sprocket to be removed.
- 6 Unlock and remove the bottom bolt securing the sprocket to the camshaft.
- 7 Turn the engine over until the timing mark on the camshaft flange is in line with the groove in the camshaft front bearing cap, i.e. No. 1 cylinder T.D.C. firing.
- 8 Remove the crankshaft pulley and timing cover.
- 9 Secure the camshaft sprocket to the support bracket with a slave nut on the threaded spigot.
- 10 Unlock and remove the top bolt securing the sprocket to the camshaft.

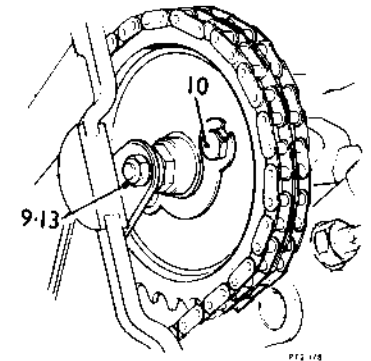
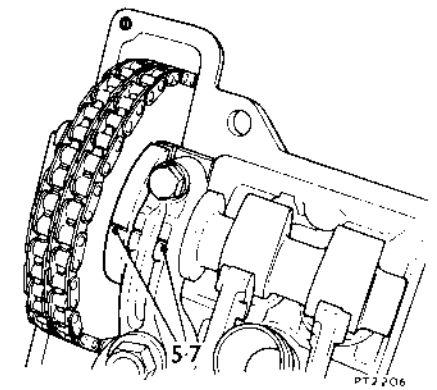

- 11 Remove the two bolts securing the hydraulic chain tensioner and remove the tensioner and guide plate — the latter being situated between the cylinder block and the tensioner, see 12.65.28.
- 12 Remove the adjusting bolt from the adjustable chain guide.
- 13 Remove the 'slave' nut holding the camshaft sprocket to the support bracket.
- 14 Remove the two bolts securing the support bracket to the cylinder block and withdraw the bracket together with a the adjustable guide  
b the straight fixed guide.
- 15 Remove the timing chain and camshaft sprocket.
- 16 Unlock and remove the bolt securing the sprocket to the jackshaft and withdraw the sprocket.
- 17 Remove the oil thrower from the crankshaft.
- 18 Withdraw the crankshaft sprocket.
- 19 Remove the crankshaft key and sprocket alignment shims.

#### Refitting

- 20 Fit the sprocket to the jackshaft, ensuring that the dowel in the jackshaft locates properly in sprocket. Secure with the retaining bolt and new lock washer.
- 21 Temporarily fit the crankshaft sprocket and check its alignment with the jackshaft sprocket using a straight-edge, as illustrated, across the two sprockets.
- 22 Adjust any misalignment by the addition of shims behind the crankshaft sprocket.

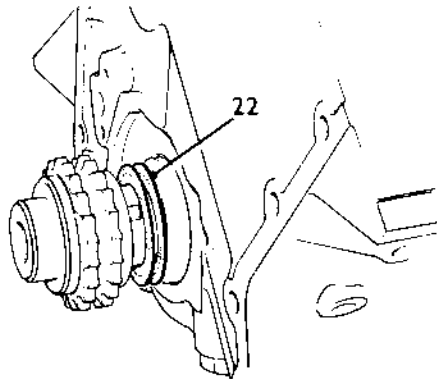
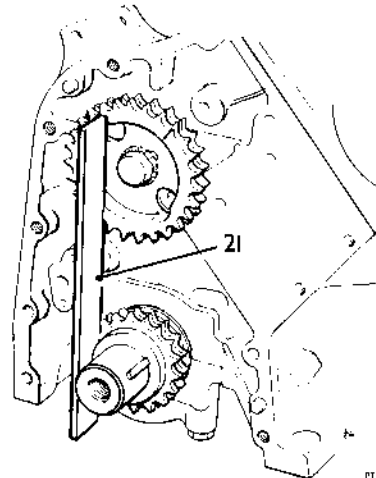
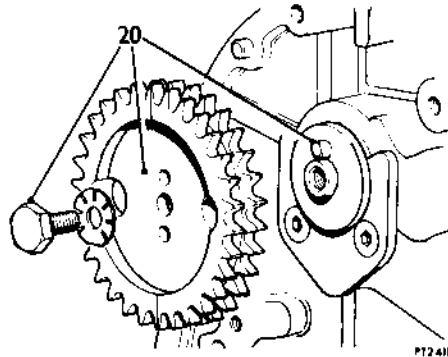
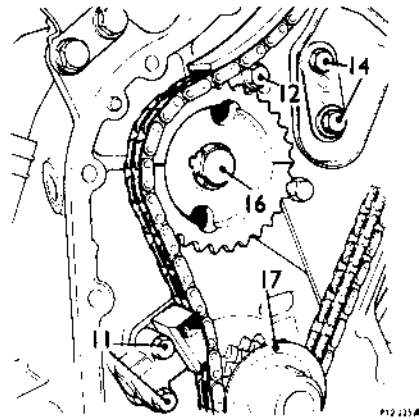

- 23 Fit the key and the crankshaft sprocket.
- 24 Fit the oil thrower — dished surface outwards.
- 25 Check that the timing mark on the camshaft flange is in line with the groove on the camshaft front bearing cap, i.e. No. 1 T.D.C. firing.
- 26 Temporarily locate the timing cover and crankshaft pulley and check that the timing mark on the pulley coincides with the zero mark on the timing cover scale.
- 27 Remove the timing cover and pulley and remove the ignition distributor cap.
- 28 Turn the jackshaft until the scribed line 'D' is equidistant between bolts 'B' and 'C' with the dowel to the left and check that the distributor rotor arm is in line with No. 1 cylinder H.T. lead segment.
- 29 Encircle the camshaft sprocket with the chain and insert through the cylinder head aperture. Locate the sprocket on the camshaft with the top retaining bolt, see instruction 10.
- 30 Keeping the chain taut on the drive side (i.e. the run between the camshaft and crankshaft sprocket), fit the chain to the crankshaft and jackshaft sprocket. Check, and if necessary adjust, the position of the jackshaft to maintain the condition in instruction 28.
- 31 Temporarily remove the engine lifting eye to enable the adjustable chain guide to be fitted.
- 32 Fit the adjustable chain guide and loosely retain with the adjusting bolt and spring washer.
- 33 Fit the camshaft sprocket support bracket together with the straight fixed guide and loosely secure with the two bolts and spring washers.
- 34 Fit a 'slave' bolt to the lower hole in the fixed guide to ensure alignment when fitting the timing cover centre bolt.
- 35 Fit the timing chain tensioner and guide and insert a 0.100 in (2.54 mm) slip gauge or feeler gauge between the body of the tensioner and the back of the slipper, dimension 'A'.  
**NOTE:** A suitable slip gauge can be made for the purpose by following the dimensioned illustration.

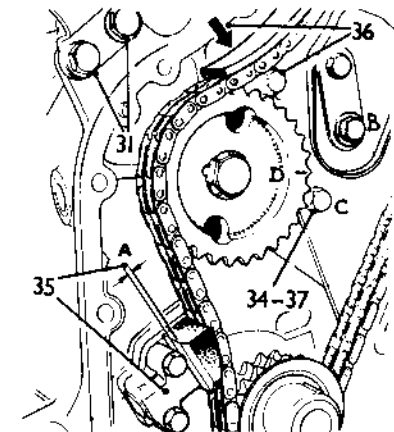
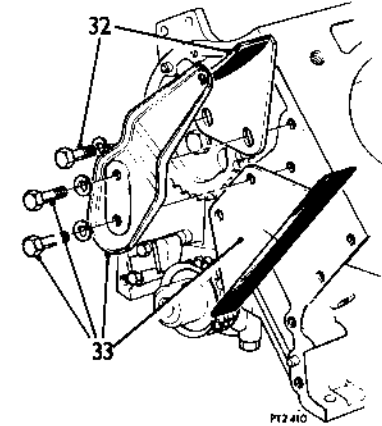
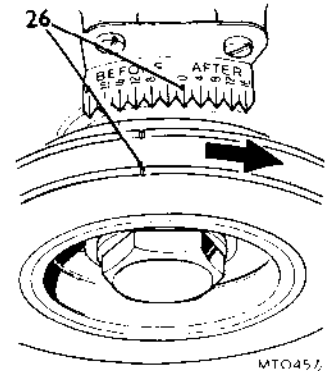

continued

- 36 Adjust the chain tension by applying pressure to the adjustable guide in direction of arrow and tighten the adjusting bolt. Withdraw the slip gauge.
- 37 Tighten the remaining chain guide retaining bolts and remove the slave bolt.
- 38 Check that the scribed line 'D' on the jackshaft sprocket is positioned as described in instruction 28.
- 39 Apply jointing compound to both sides of both new gaskets and place in position on the cylinder block.
- 40 Locate the timing chain cover over the two dowels and secure with the retaining bolts. Ensure that the centre bolt is fitted with a fibre washer under the head.
- 41 Fit the alternator adjusting link.
- 42 Temporarily fit the crankshaft pulley and check that the timing mark on the pulley is in line with the zero mark on the timing chain cover and the mark on the camshaft flange coincides with the groove on the camshaft front bearing cap. Remove the pulley.
- 43 Remove the protective material guarding access to the sump and fit the two front sump bolts and tighten the slackened side bolts, see 12.65.01.
- 44 Fit the two nuts and bolts securing the timing cover to the cylinder head.
- 45 Turn the camshaft 180° and fit the remaining camshaft retaining bolt. Lock both bolts with the tab washers. Refer to 12.13.01, instructions 17 and 18.
- 46 Check that the threaded spigot on the camshaft sprocket does not foul the location hole in the support bracket.
- 47 Fit the camshaft cover.
- 48 Fit the crankshaft pulley.
- 49 Fit the fan unit assembly.
- 50 Re-connect the battery.
- 51 Fit the bonnet.

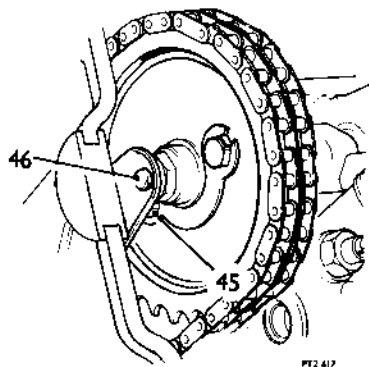
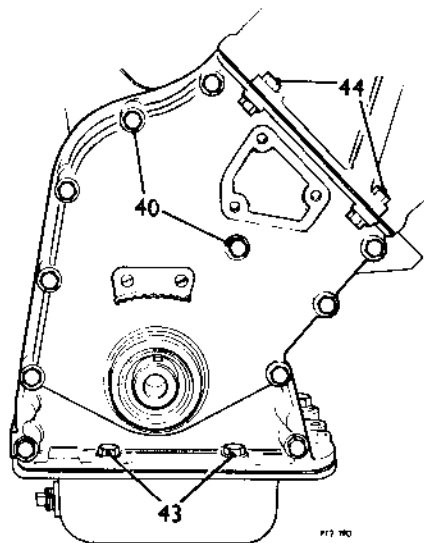
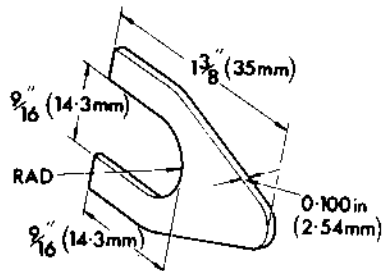

## TIMING CHAIN TENSIONER

Remove and refit

12.65.28

## Removing

- 1 Remove the timing chain cover, see 12.65.01.
- 2 Remove the tensioner retaining bolts and spring washers.
- 3 Remove the tensioner from the engine.
- 4 Remove the backplate between the tensioner body and cylinder block.

## Dismantling

- 5 Press in the slipper and remove it from the tensioner body.
- 6 Remove the ratchet and spring.

## Examination

- 7 Check the slipper pad for wear, and renew if necessary. Check that the oil outlet hole is clear.
- 8 Examine the ratchet for wear and renew if suspect.
- 9 Check the spring and renew if broken or not in accordance with DATA.
- 10 Examine the tensioner body and check that the oil inlet hole is clear.

## Reassembling

- 11 Insert the spring into the slipper bore.
- 12 Fit the ratchet into the bore and turn clockwise with an Allen key to lock it in a retracted position.
- 13 Fit the slipper assembly to the tensioner body.  
**NOTE:** To prevent the tensioner releasing while fitting, insert a spacer between the tensioner body and the back of the slipper.
- 14 Fit the tensioner assembly and backplate to the cylinder block, taking care not to allow the tensioner to release. Secure with the two bolts and spring washers.

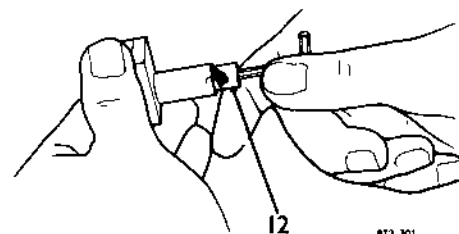
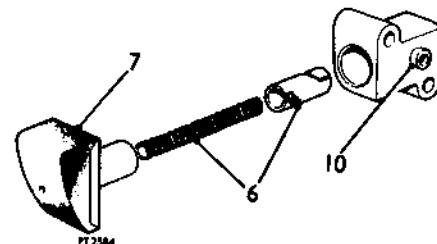
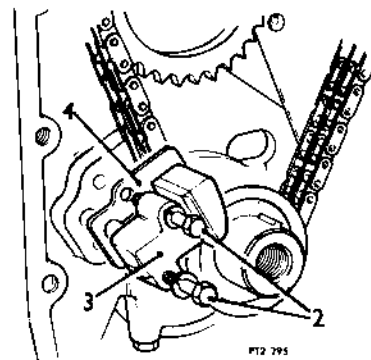



- 15 Insert a 0.100 in (2.54 mm) feeler gauge or slip gauge (see Note below) between the slipper and tensioner body, dimension A.
- NOTE:** A convenient slip gauge can be made for the purpose by following the dimensioned drawing, see 12.65.12.
- 16 Slacken the two bolts securing the top chain guide.
- 17 Press down — in direction of arrow — on top of the chain guide until the feeler or special slip gauge is a sliding fit.
- 18 Whilst holding the guide and tensioner in this position tighten the two guide bolts.
- 19 Remove the feeler or slip gauge.
- 20 Refit the timing chain cover, see 12.65.28.

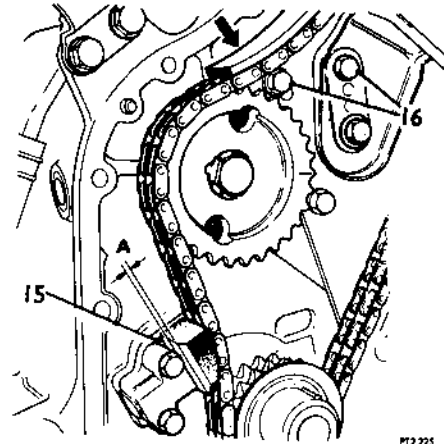

#### DATA

Tensioner spring — free length . . . . . 2.750 in (69.8 mm)

**CRANKCASE EMISSION CONTROL -****Description**

The engine breather outlet from the camshaft cover is connected by pipes to ports in the side of the carburetors which lead to the depression area between the throttle disc and piston.

When the engine is running, the depression created draws engine fumes and blow-by gases from the crankcase into the combustion chambers.

- 1 Crankcase purge line
  - 2 Carburetter float chamber vent pipe
  - 3 Canister purge pipe
  - 4 Primary canister
  - 5 Secondary canister
  - 6 Fuel tank vent pipe
  - 7 Purge air to canister
  - 8 Fuel pump
  - 9 Fuel pipe
  - 10 Anti-run-on valve
  - 11 Electrical connections for anti-run-on valve
  - 12 Manifold vacuum line
- A. 0.280 to 0.300 in restrictors  
 B.  $\frac{3}{8}$  in restrictor

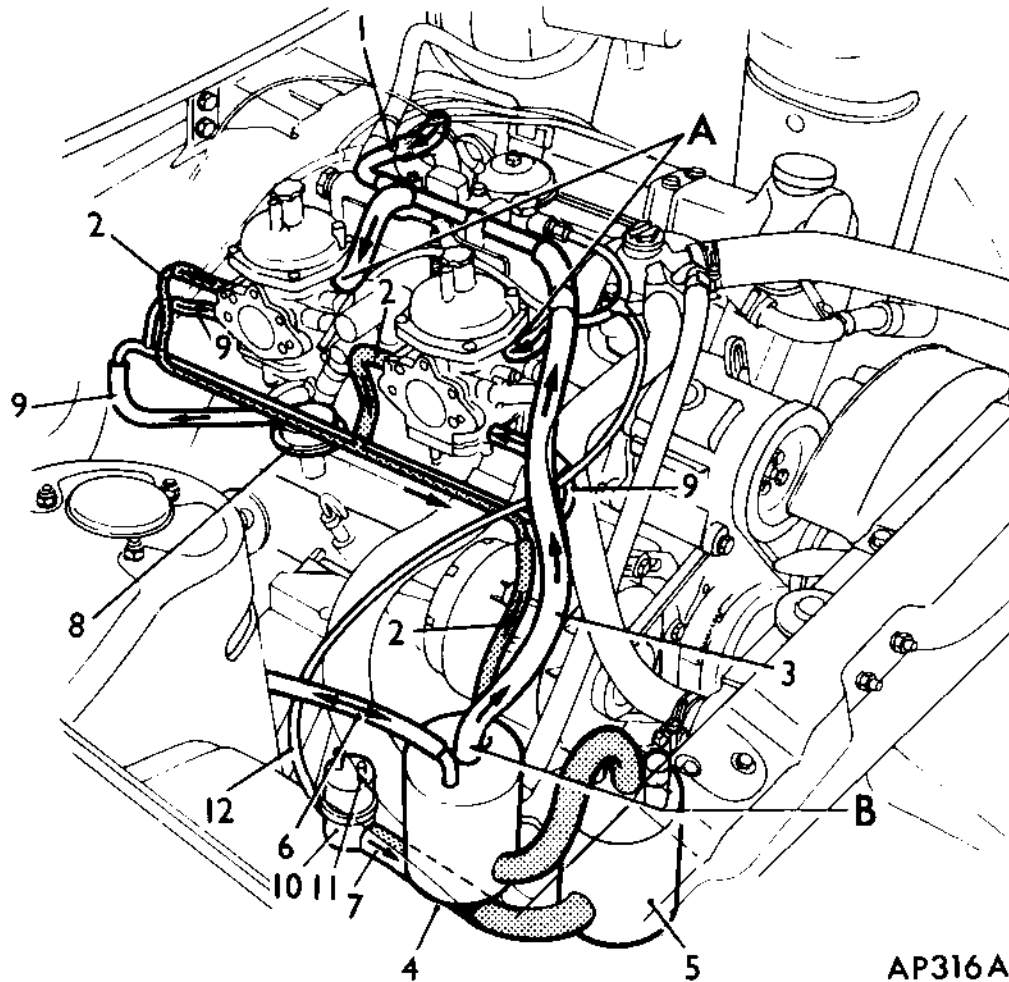
**CALIFORNIA SPECIFICATION**

AP316A

## FEDERAL SPECIFICATION

- 1 Crankcase purge line
  - 2 Carburettor float chamber vent pipe
  - 3 Canister purge pipe
  - 4 Primary canister
  - 5 Secondary canister
  - 6 Fuel tank vent pipe
  - 7 Purge air to canister
  - 8 Fuel pump
  - 9 Fuel pipe
- A. 0.280 to 0.300 in restrictors.  
B.  $\frac{1}{32}$  in restrictor

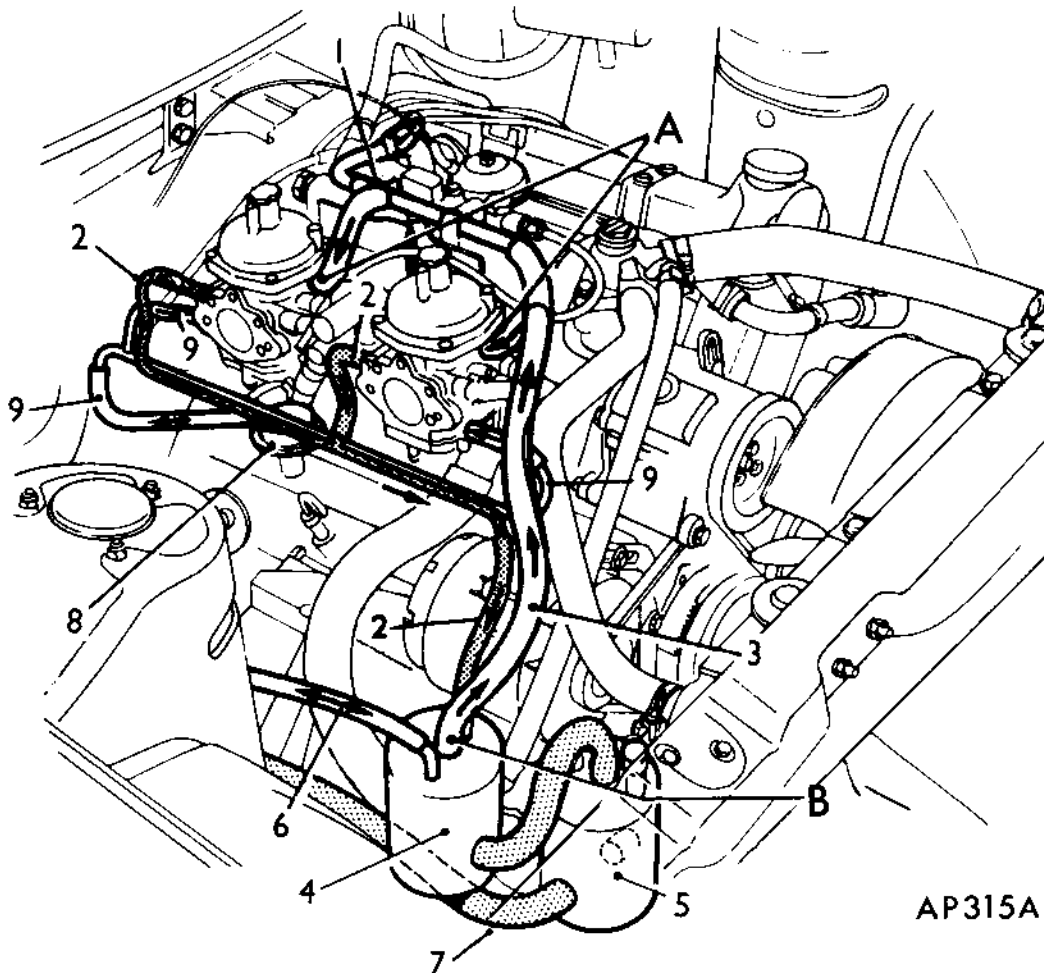

AP315A

CANADIAN SPECIFICATION

- 1 Crankcase purge line
- 2 Carburetter float chamber vent pipe
- 3 Canister purge line
- 4 Adsorption canister
- 5 Fuel tank vent pipe
- 6 Anti-run-on valve
- 7 Manifold vacuum line
- 8 Electrical connections for anti-run-on valve
- 9 Purge air to canister
- 10 Flame arrestor
- A.  $\frac{3}{32}$  in restrictor
- B.  $\frac{1}{8}$  in restrictor

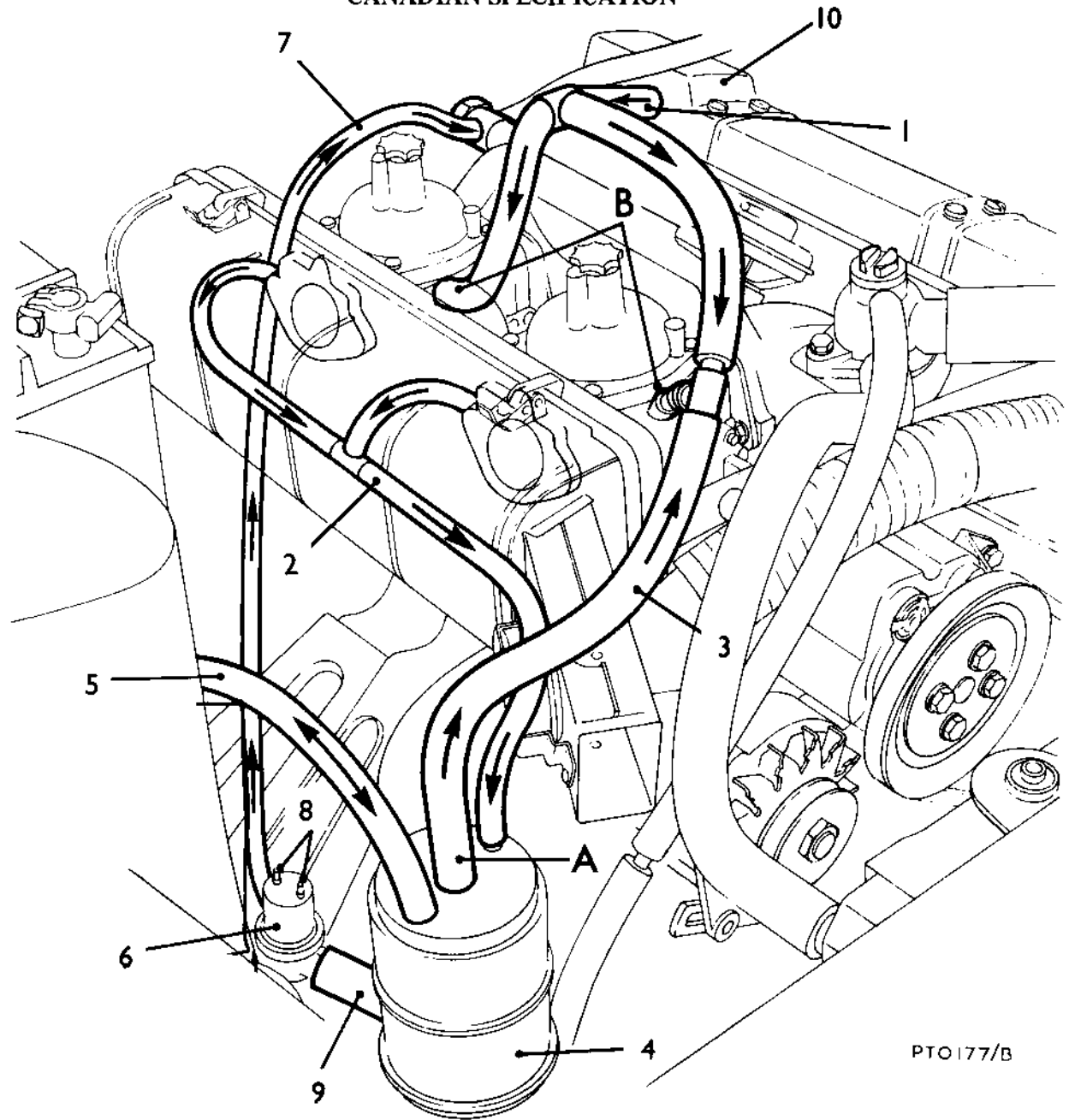

PTO177/B

## EVAPORATIVE LOSS CONTROL SYSTEM

### Description

The system is designed to prevent the emission to atmosphere of fuel vapour. The vapour collected from the fuel tank and carburettors is stored in an adsorption canister while the engine is at rest. Once the engine is running the vapour is purged from the canister and passed to the combustion chambers.

### Fuel Tank

When the fuel tank filler cap is correctly fitted the system is sealed and venting of the tank can only take place via a vapour separator to the adsorption canister.

To ensure that sufficient space is available to accommodate fuel displaced by expansion due to increased temperatures, a fuel filling restrictor is incorporated in the vapour separator which prevents the tank being completely filled with fuel.

### Adsorption canister

The adsorption canister provides a means of storing fuel vapour whilst the car is parked. The canister, which is not serviceable, contains active charcoal granules. Vapour tubes from the fuel tank, carburettor float chambers, and the purge pipe from the engine breathing system are connected to ports on top of the canister. The manifold vacuum pipe is connected to the anti-run on valve at the base of the canister.

Fuel vapour entering the canister through the vapour pipes is adsorbed by the charcoal granules. When the engine is started air is drawn by the engine breather system through the purge tube, at the bottom of the canister. The resulting purging action by the air passing over the granules carries the vapours through the engine breather system to the combustion chambers.

- 1 Adsorption canister.
- 2 Fuel vapour separator.
- 3 Fuel fill restrictor.
- 4 Sealed cap.
- 5 Fuel filler pipe.
- 6 Maximum fuel level.

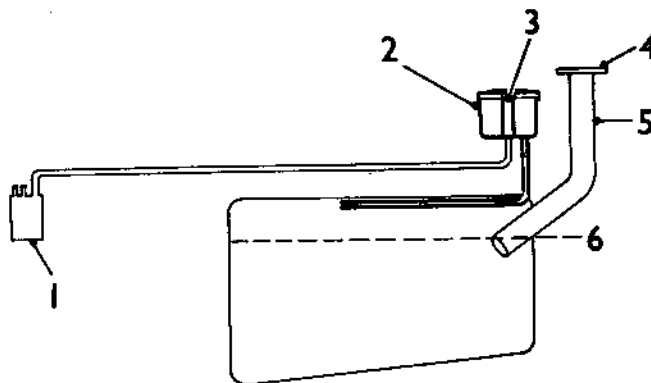

### Vapour separator and restrictor

Vapour from the tank passes into the vapour separator and through two breather notches in a seat on which a taper plug rests. These small notches by virtue of their size allow only a limited flow of vapour as would be the case under normal running and stationary conditions. When the tank is being filled, however, the vapour air flow increases and the small notches create a restriction. Once the fuel has reached a level just above the filler tube this restriction and resulting pressure limits the quantity of fuel that the tank will accommodate to a predetermined maximum level.

*continued*

PTO 44

- 1 Breather notches.
- 2 Fuel tank pipe connection.
- 3 Adsorption pipe connection.

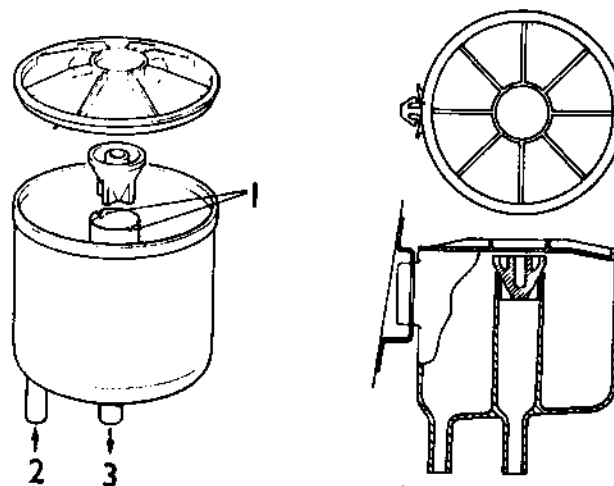

**Anti-run-on valve**

The purpose of the valve is to prevent the engine 'running-on' once the ignition has been switched off.

The solenoid operated valve is connected by a hose to the base of the adsorption canister. The manifold vacuum hose is connected to the opposite side of the valve. The solenoid is connected electrically by two leads, one to the oil pressure switch and the other to the ignition switch.

When the ignition is turned-off a contact in the switch closes and energizes the solenoid thus opening the valve to manifold vacuum. At the same instant the purge vent to atmosphere closes.

Since the throttle is now closed the carburetter vent valve has opened the passage to the float chamber. Partial vacuum has now been transferred from the base of the adsorption canister, via the float chamber vent pipe, to the float chamber thus preventing fuel entering the carburetter jet.

When the engine stops revolving the drop in oil pressure activates the oil pressure switch, opens the circuit and de-energizes the solenoid valve.

- 1 Engine.
- 2 Carburetter vent valve.
- 3 Adsorption canister.
- 4 Fuel tank.
- 5 Ignition switch.
- 6 Oil pressure switch.
- 7 Manifold vacuum.
- 8 Solenoid valve.

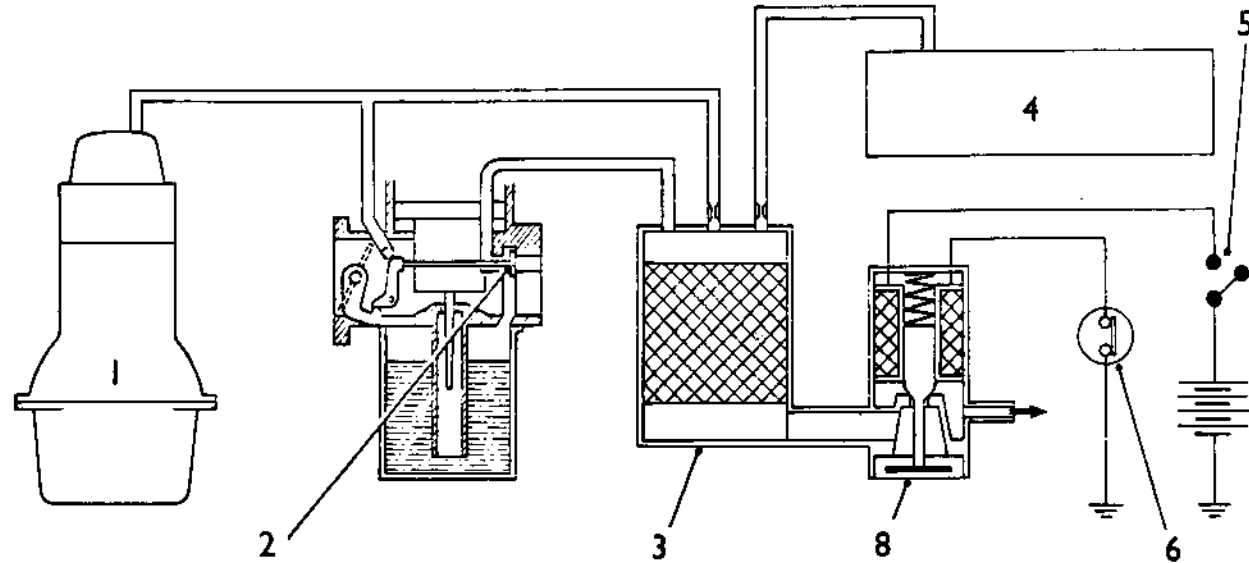

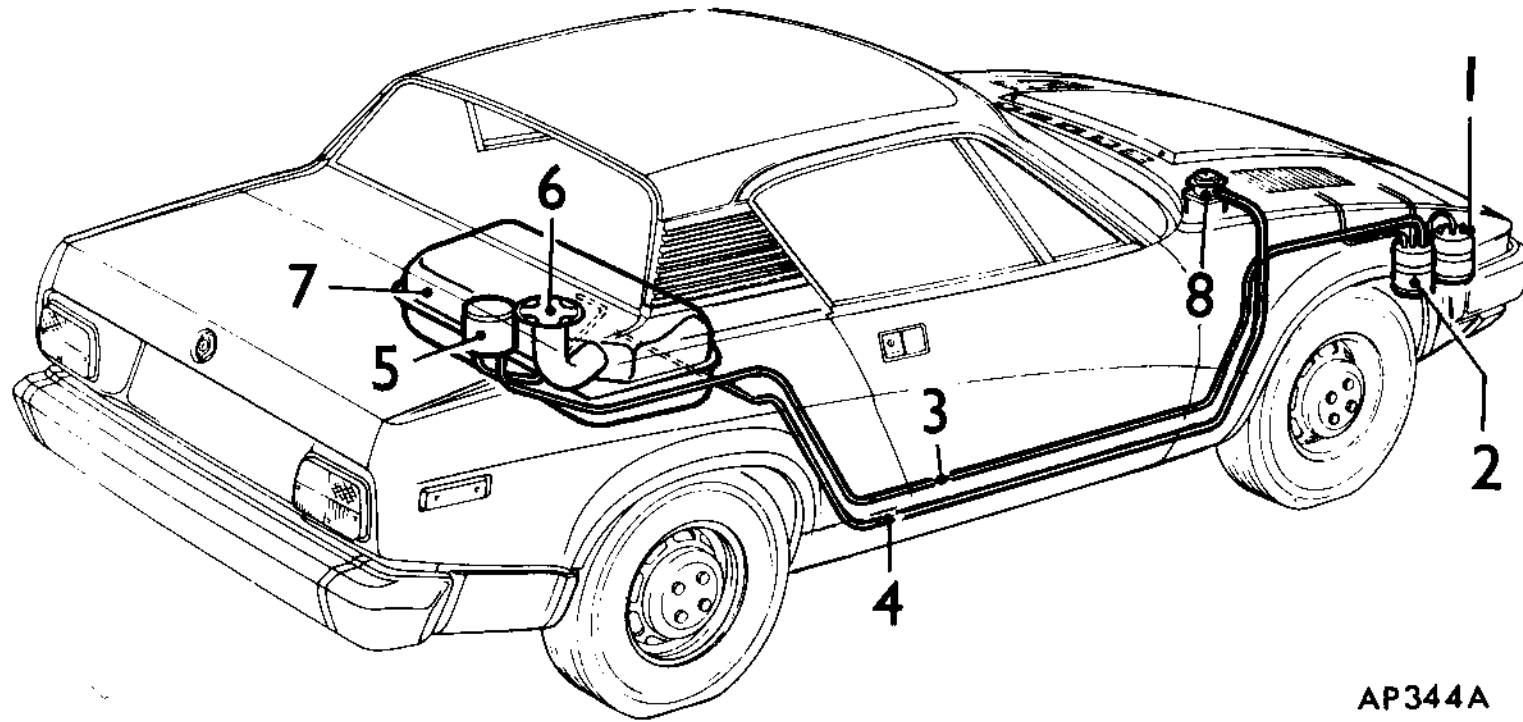

AP344A

- 1 Primary canister
- 2 Secondary canister
- 3 Vapour feed line
- 4 Fuel feed line
- 5 Fuel vapour separator
- 6 Sealed filler cap
- 7 Limited fill fuel tank
- 8 Fuel pump

NOTE: An anti-run-on valve is fitted to California and Canadian Specification vehicles.

## EXHAUST EMISSION CONTROL

### Description

The following, individually described components are fitted to comply with legislation aimed at reducing the hydrocarbon, nitric oxide, and carbon monoxide content of the exhaust gases emitted to the atmosphere.

#### Air pump

The rotary vane type air pump is fitted at the front of the engine and driven by a belt from a crankshaft pulley.

The pump delivers air under pressure to each of the four exhaust ports via a diverter and relief valve, check valve and air inlet manifold.

The pressurized air combines with the exhaust gases to continue and assist in making more complete the oxidization process in the exhaust system.

- 1 Inlet port.
- 2 Exhaust port.
- 3 Vanes.
- 4 Rotor.
- 5 Carbon sealing shoes.
- 6 Bearings.

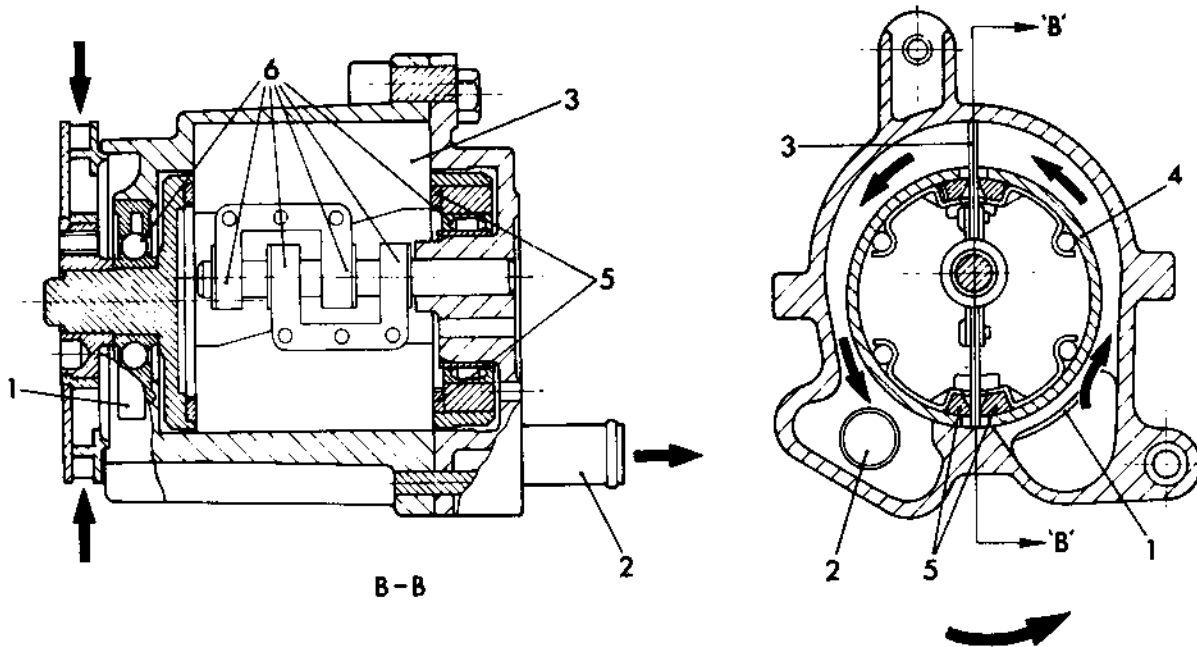

### Diverter and Relief valve

#### Diverter and Relief valve

This combined valve is incorporated to divert the air from the pump during deceleration to prevent backfire. The relief valve allows excessive air pressure at high engine speeds to discharge to the atmosphere.

#### Check valve

The check valve is a one-way valve positioned between the diverter and relief valve and the air manifold. Its purpose is to protect the pump from back-flow of exhaust gases. The valve closes if the pump pressure falls while the engine is running, should, for example, the drive belt break.

#### Air Manifold

The air manifold is finally responsible for delivering the pumped air directly into the exhaust ports through four small branch pipes.

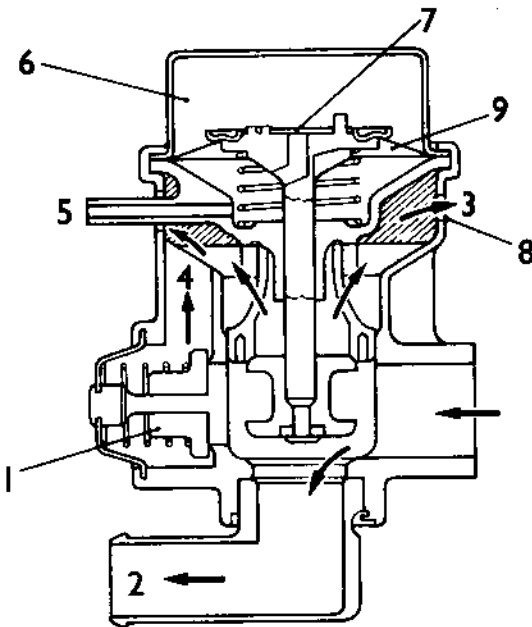

- 1 Relief valve.
- 2 Normal flow from air pump.
- 3 Diverted air.
- 4 Relief valve air.
- 5 Manifold vacuum.
- 6 Timed vacuum.
- 7 Timing feature.
- 8 Diverter and relief valve ports.
- 9 Diaphragm.

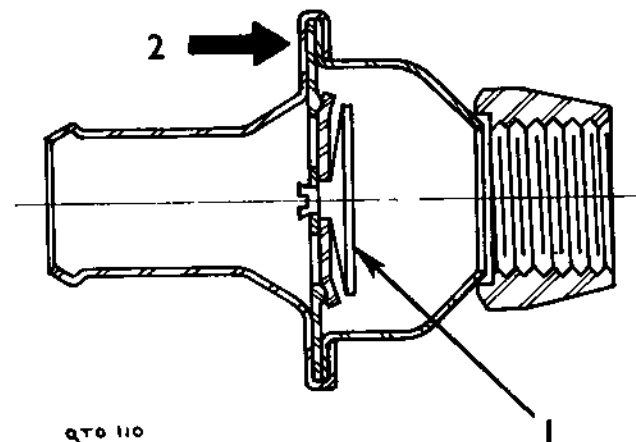

- 1 Valve diaphragm.
- 2 Direction of flow.



### Exhaust gas recirculation system

Exhaust gas is taken from numbers 2 and 3 cylinders by two drillings to each side of the cylinder head. An exhaust gas recirculation valve (E.G.R. valve) mounted on a passage on the inlet manifold controls the flow to the balance pipe on the inlet manifold. The control signal is taken from a throttle-edged tapping which gives no recirculation at idle speed or full load, but gives an amount of recirculation dependent on the vacuum signal and metering profile of the valve. An E.G.R. control valve cuts the signal to the E.G.R. valve when the choke is in operation by opening an air bleed into the vacuum line.

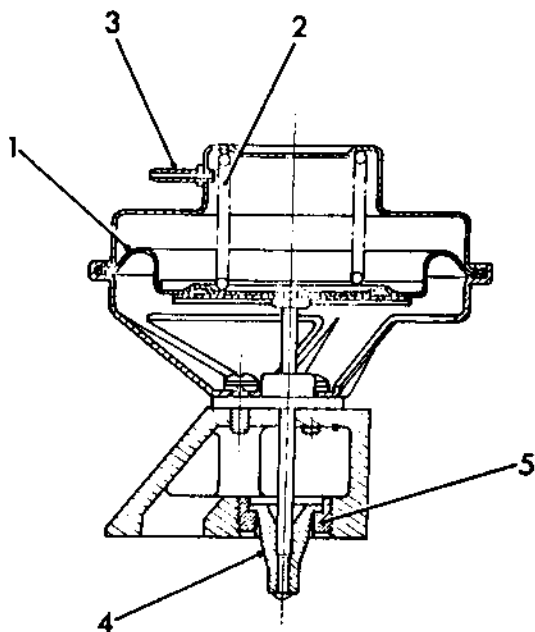

- 1 Diaphragm.
- 2 Spring.
- 3 To vacuum source.
- 4 Metering pintle.
- 5 Valve seat adjustable for production setting and sealed.

### E.G.R. Control valve

This valve is attached to the rear carburetter and is actuated by a heel on the fast idle cam. The choke knob on the fascia must be pulled out approximately  $\frac{1}{4}$  in. before the control valve operates and must be pushed-in within  $\frac{1}{10}$  in. or fully home before the E.G.R. valve is operational.

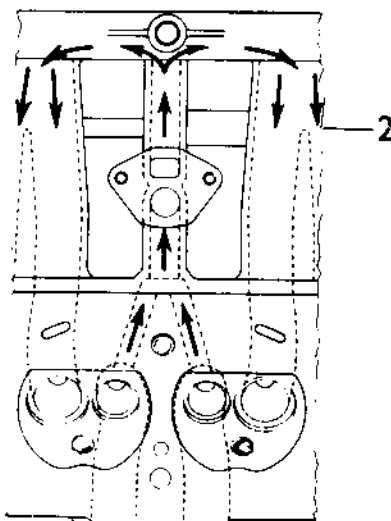

### CANADIAN SPECIFICATION

- 1 E.G.R. valve.
- 2 Inlet manifold.
- 3 Exhaust port.
- 4 Choke cam.
- 5 E.G.R. cut off valve.
- 6 Fuel tap.
- 7 Vacuum source throttle edge tapping.

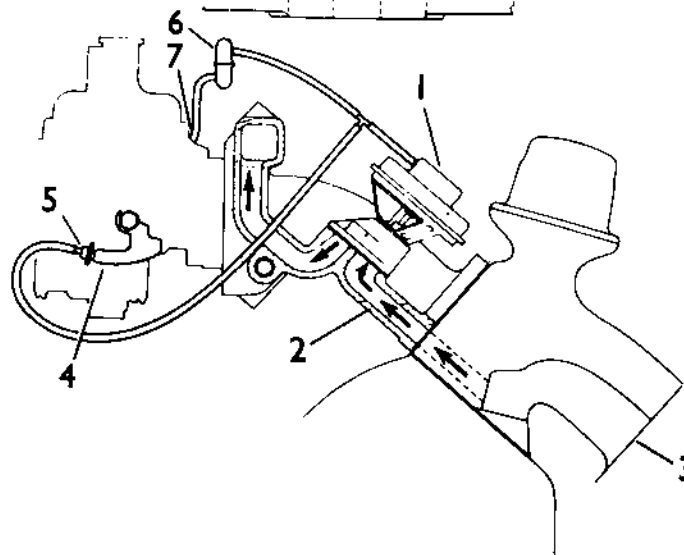

PTO 150

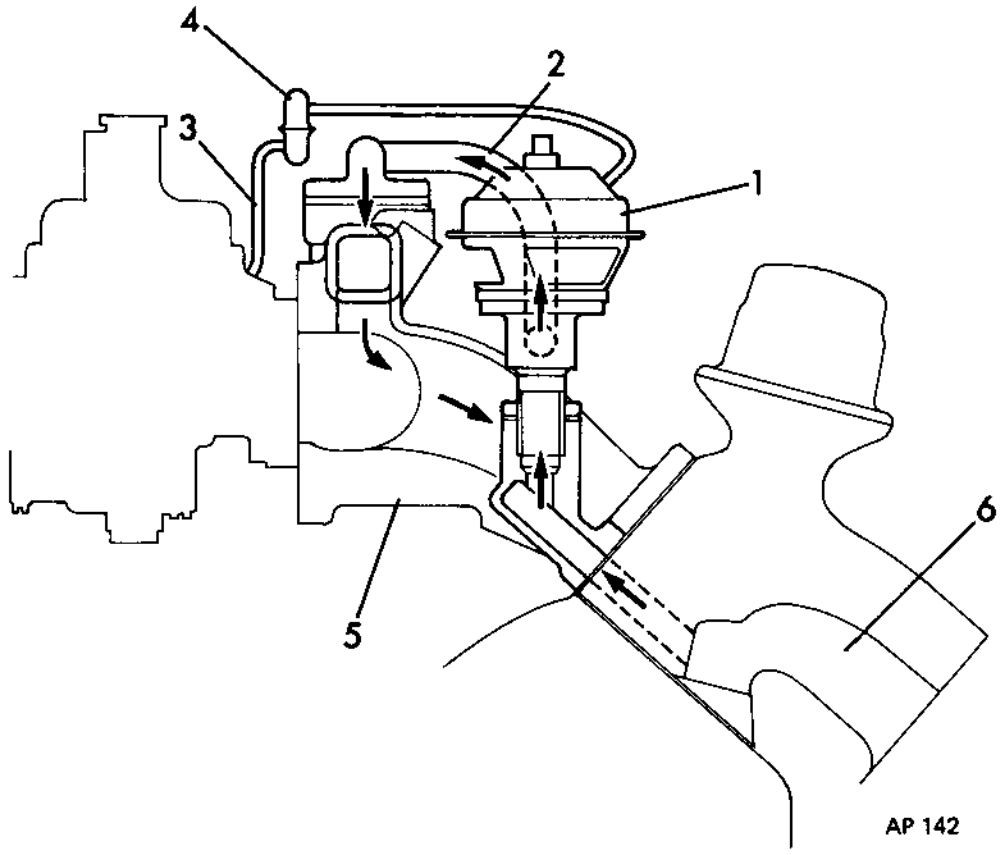

AP 142

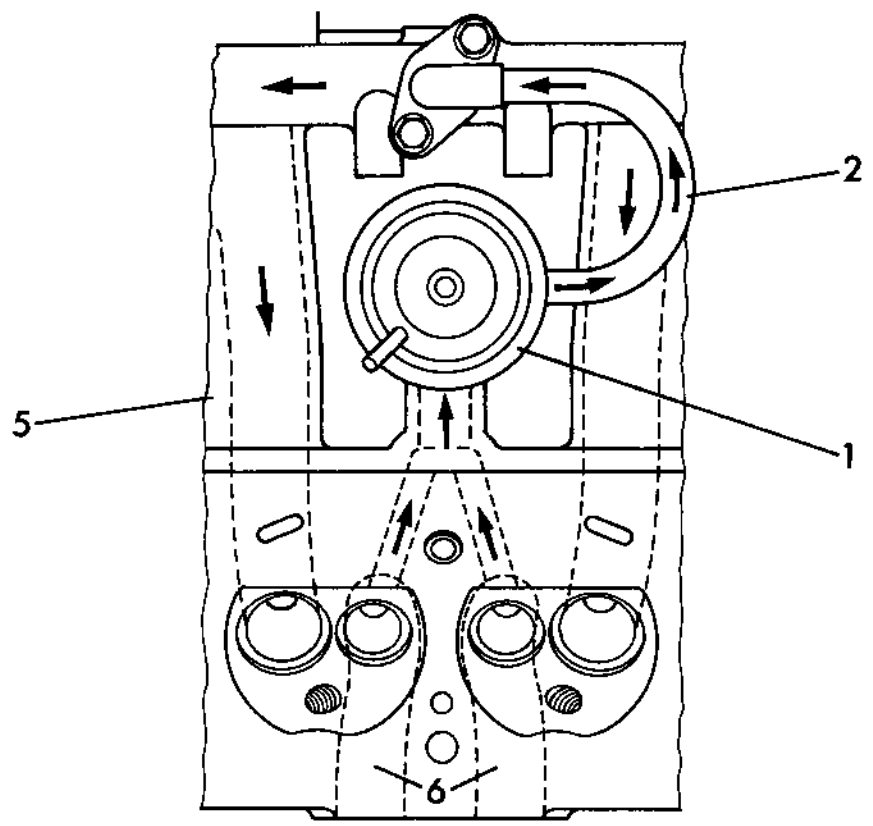

- 1 E.G.R. valve.
- 2 E.G.R. pipe.
- 3 Throttle edge tapping.
- 4 Fuel trap.
- 5 Inlet manifold.
- 6 Exhaust port.

## VAPOUR SEPARATOR

Remove and refit 17.15.02

- 1 Open the boot and remove the four screws retaining the access panel.
- 2 Remove the fuel filler cap and filler assembly. 19.55.08.
- 3 Pull-off the two hoses from the vapour separator.
- 4 Pull the vapour separator laterally from its retaining clip.

### Refitting

- 5 Push the vapour separator into its retaining clip.
- 6 Fit the hose from the tank to the L.H. connection.
- 7 Fit the hose to the adsorption canister to the R.H. connection.
- 8 Fit the fuel filler assembly and cap. 19.55.08.
- 9 Refit the access panel.

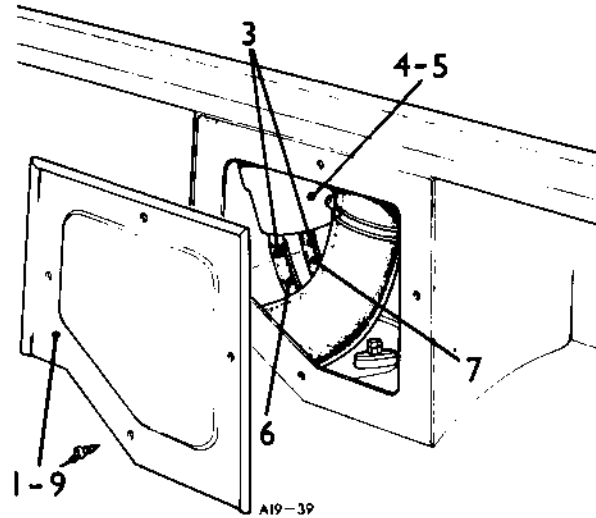

## ADSORPTION CANISTER — Canadian Specification only

Remove and refit 17.15.13

### Removing

- 1 Disconnect the canister to run-on valve pipe. (where fitted).
- 2 Disconnect from the canister:
  - a The canister to fuel tank pipe.
  - b The canister purge pipe.
  - c Carburettor vent pipe.
- 3 Slacken the clamp nut.
- 4 Remove the canister.

### Refitting

- 5 Secure the canister in the clamp.
- 6 Reverse instructions 1 to 3.

## ADSORPTION CANISTERS — Except Canadian Specification

Remove and refit 17.15.13

### Removing

- 1 Disconnect from the primary canister:
  - a The canister purge pipe.
  - b The carburettor float chamber vent pipe.
  - c The fuel tank vent pipe.
  - d The connecting pipe from the lower canister.
- 2 Slacken the clamp nut.
- 3 Remove the canister.
- 4 Remove the connecting pipe between the primary and secondary canisters.
- 5 Remove the purge air canister pipe from the secondary canister.
- 6 Slacken the clamp nut.
- 7 Remove the canister.

### Refitting

- 8 Reverse instructions 1 to 7.

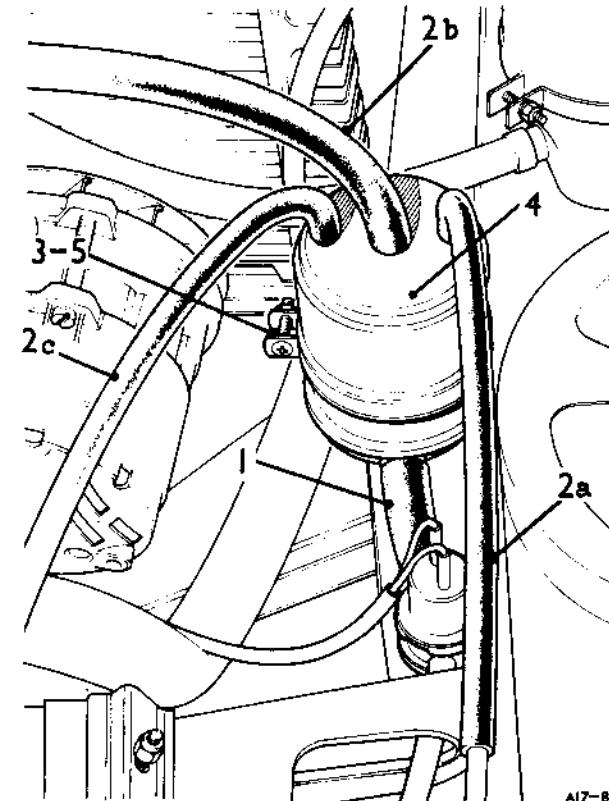
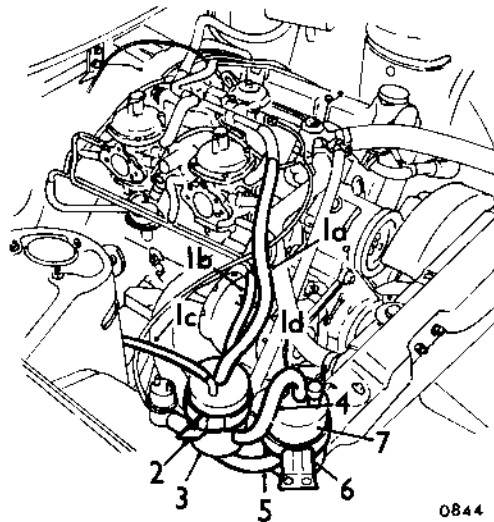

### AIR PUMP

Remove and refit 17.25.07

#### Removing

- 1 Disconnect the battery.
- 2 Disconnect the hose from the air pump.
- 3 Remove the adjusting nut and bolt.
- 4 Remove the pivot bolt and nut.
- 5 Remove the belt from the pump pulley.
- 6 Withdraw the pivot bolt until the head contacts the radiator.
- 7 Remove the pump.

#### Refitting

- 8 Fit the pump to its carrier bracket and loosely secure with the pivot nut and bolt.
- 9 Fit the adjusting nut and bolt.
- 10 Fit the belt onto the pulleys and correctly tension the belt. 17.25.13.
- 11 Reconnect the hose.
- 12 Reconnect the battery.

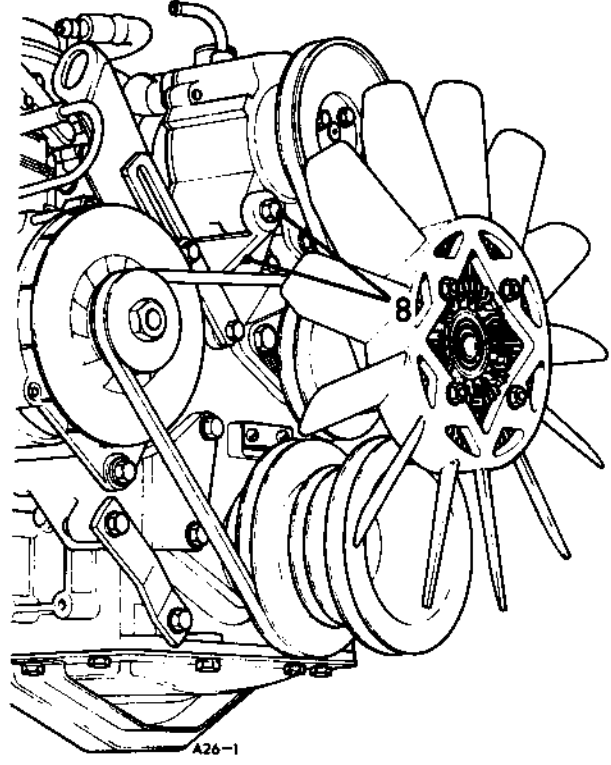
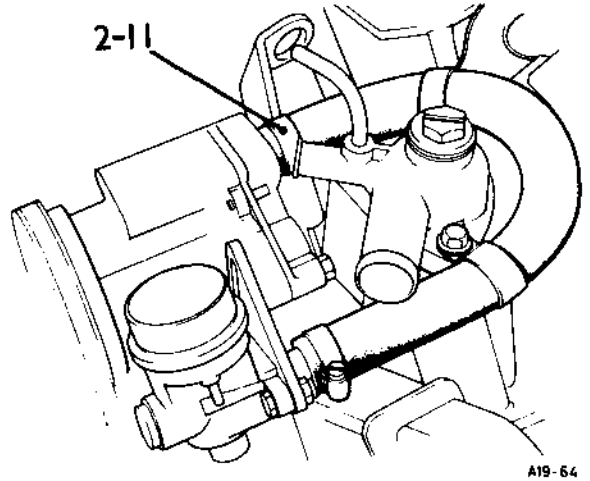
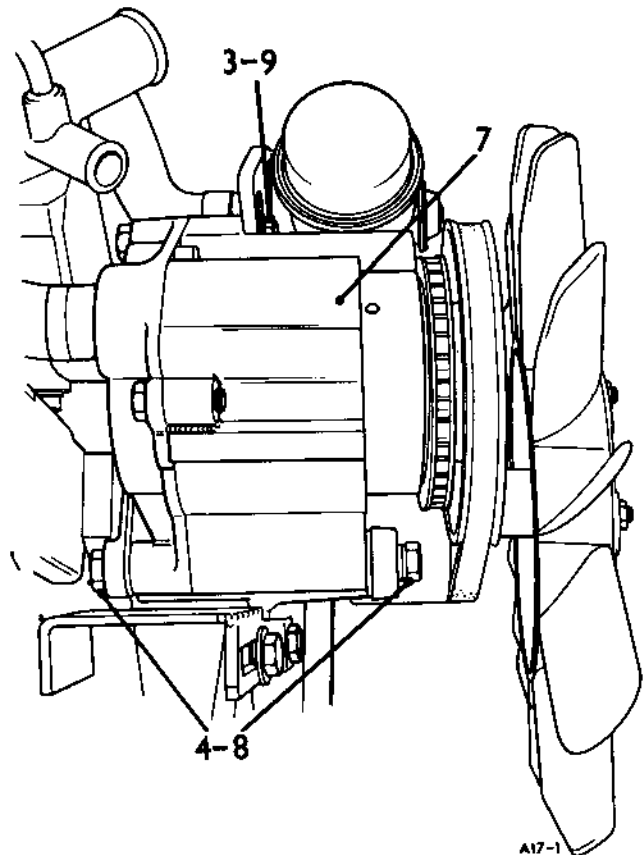

## AIR PUMP DRIVE BELT

### Tensioning

17.25.13

- 1 Disconnect the battery.
- 2 Slacken the adjusting nut and bolt.
- 3 Slacken the pivot bolt and nut.
- 4 With care use a lever on the pump to tension the belt and tighten the adjusting nut and bolt.
- 5 Tighten the pivot bolt.
- 6 Check the belt tension which is correct when 3/8 in. (9.5 mm) overall lateral movement is possible at the mid-point of the run.
- 7 Reconnect the battery.

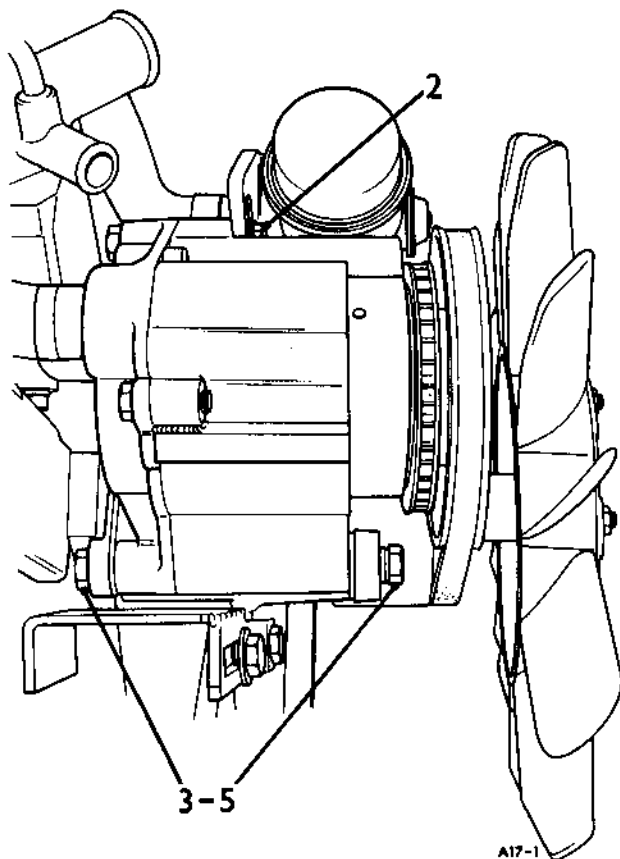

## AIR PUMP DRIVE BELT

### Remove and refit

17.25.15

#### Removing

- 1 Disconnect the battery.
- 2 Remove the fan guard.
- 3 Remove the fan blades. 26.25.06.
- 4 Slacken off air pump belt tension.
- 5 Remove drive belt from the pulleys.

#### Refitting

- 6 Feed the belt onto the pulleys.
- 7 Tension the drive belt. 17.25.13.
- 8 Fit the fan blades. 26.25.06.
- 9 Reconnect the battery.

## AIR DISTRIBUTION MANIFOLD

### Remove and refit

17.25.17

#### Removing

- 1 Disconnect the hose from the diverter and relief valve.
- 2 Unscrew the four union nuts securing the air injection tubes into the exhaust ports.
- 3 Withdraw the air distribution manifold complete with the check valve.
- 4 Hold the air distribution manifold in a vice by the hexagon and remove the check valve.

#### Refitting

- 5 Reverse instructions 1 to 4.

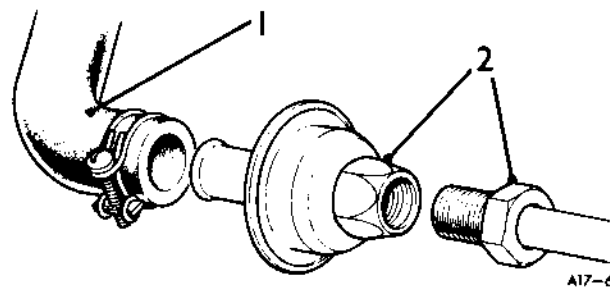
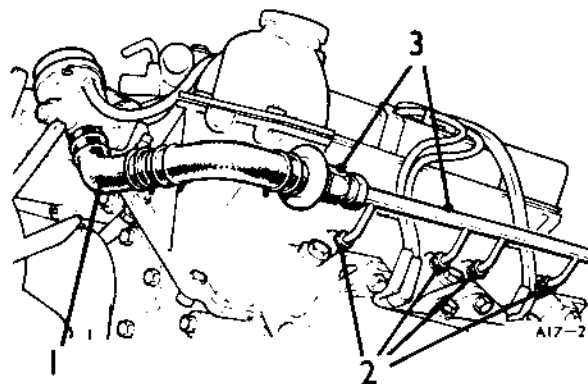

## CHECK VALVE

### Remove and refit

17.25.21

#### Removing

- 1 Disconnect the air hose from the diverter and relief valve from the check valve.
- 2 Using two open-ended spanners – one on the air distribution manifold hexagon, to support the manifold, and the other to remove the check valve anti-clockwise.

**CAUTION:** Do not impose any strain on the air manifold.

#### Refitting

- 3 Reverse instructions 1 and 2.

**CHECK VALVE**

Test 17.25.22

**Testing**

**CAUTION:** Do not use a pressure air supply for this test.

- 1 Remove the check valve. 17.25.21.
- 2 Blow through the valve orally in both directions in turn. Air should only pass through the valve when blown from the hose connection end. Should air pass through the valve when blown from the air manifold end, renew the valve.
- 3 Refit the check valve. 17.25.21.

**DIVERTER AND RELIEF VALVE**

Remove and refit 17.25.25

**Removing**

- 1 Disconnect the battery.
- 2 Disconnect the pump to valve hoses.
- 3 Disconnect the air hose from the valve to the check valve.
- 4 Disconnect the diverter valve triggering vacuum pipe.
- 5 Remove the air pump adjusting nut and bolt.
- 6 Remove the bolt securing the common bracket holding the valve and air pump drive belt adjustment.
- 7 Remove the valve complete with bracket.
- 8 Remove the two nuts and bolts retaining the valve to the bracket.
- 9 Remove the valve and gasket.

**Refitting**

- 10 Fit the valve to the bracket using a new gasket.
- 11 Fit the bracket complete with valve to the engine.
- 12 Fit the drive belt tensioning nut and bolt.
- 13 Connect the check valve to diverter air hose.
- 14 Connect the air pump to diverter valve hose.
- 15 Connect the diverter air valve triggering vacuum pipe to the valve.
- 16 Check and if necessary adjust the air pump drive belt tension.
- 17 Reconnect the battery.

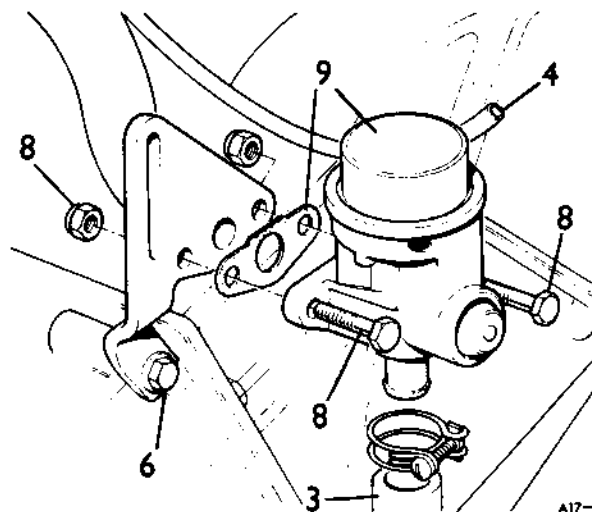

## AIR INTAKE TEMPERATURE CONTROL SYSTEM

Description

17.30.00

The carburettors are tuned to function most efficiently at an air intake temperature of 100° F (38° C).

The temperature is maintained by a sensing device incorporated in the air cleaner. The sensor allows inlet manifold vacuum to operate a flap valve in the air cleaner intake. The valve controls the entry of cold air at under bonnet temperature and hot air drawn from a duct on the exhaust manifold.

In order to maintain full vacuum influence on the flap valve when the manifold depression is temporarily destroyed during sudden throttle openings, a one-way valve is fitted in the vacuum line from the inlet manifold to the temperature sensor.

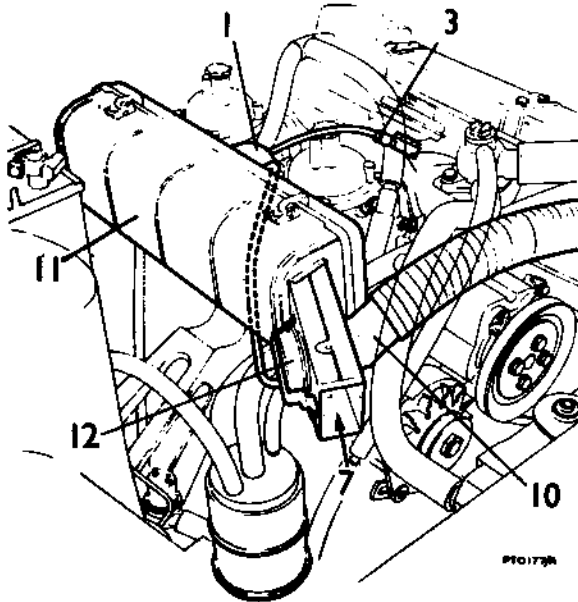

## AIR INTAKE TEMPERATURE CONTROL SYSTEM

Function test

17.30.01

- 1 Inspect the condition and security of the following:
  - a Hot air inlet hose.
  - b The vacuum hose from the one-way valve to the temperature sensor unit.
  - c The vacuum hose from the temperature sensor unit to the servo motor in the air cleaner outer cover.
- 2 With the engine and air cleaner cold i.e. below 100° F (38° C) check that the flap valve is in the cold air position i.e. parallel with the rectangular air intake – illustration A thus allowing cold air (ambient) only to enter the air cleaner.
- 3 Start the engine and allow it to idle for a few seconds. The flap valve should move immediately to the hot air position – illustration B thereby permitting only hot air via the hot air hose to enter the air cleaner.
- 4 With the flap valve in the hot air position – illustration B, attempt to lower the engine vacuum by increasing the engine speed suddenly and holding for a few seconds and check that the flap valve has remained in the hot air position.
- 5 Run the engine until normal operating temperature is reached and under bonnet temperature is above 100° F (38° C) and check that the flap valve has moved to the cold air position – illustration A.

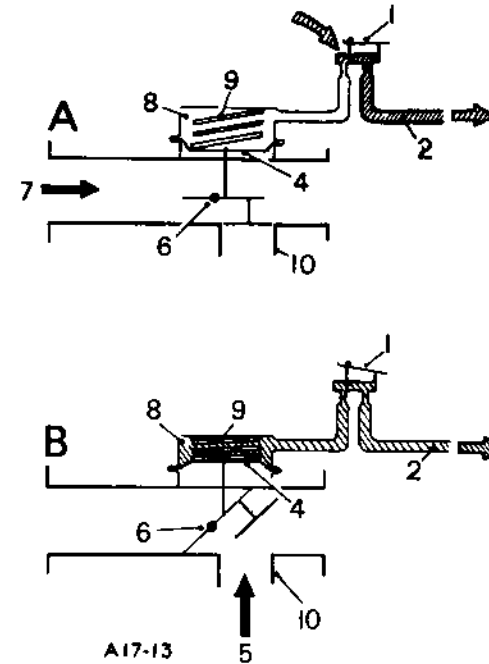

- 1 Temperature sensor.
- 2 Inlet manifold.
- 3 One way valve.
- 4 Valve diaphragm.
- 5 Hot air intake.
- 6 Flap valve.
- 7 Cold air intake.
- 8 Vacuum side of motor.
- 9 Return spring.
- 10 Hot air hose.
- 11 Air cleaner cover.
- 12 Motor case.

*continued*

## AIR INTAKE TEMPERATURE CONTROL – FAULT FINDING

SYMPTOM	POSSIBLE CAUSE	ACTION
Poor or erratic idle Hesitation or flat spot (cold engine) Excessive fuel consumption Lack of power Engine overheating	Hot air inlet hose loose, adrift or blocked	Check hot air inlet hose for condition and security. Renew if necessary
Poor or erratic idle Hesitation or flat spot (cold engine) Excessive fuel consumption Lack of power Engine cuts-out or stalls (at idle) Engine 'runs-on' Engine 'knocks or pinks' Rich running (excess CO)	Flap valve jammed	Check operation of flap valve 17.30.01 If fault cannot be rectified renew air cleaner outer cover which includes flap valve. See 19.10.01
Poor or erratic idle Hesitation or flat spot (cold engine) Excessive fuel consumption Lack of engine power Engine cuts-out or stalls (at idle) Engine misfires Lean running (low CO)	Vacuum pipes disconnected or leaking	Check the vacuum pipes for security and deterioration. Renew if necessary

SYMPTOM	POSSIBLE CAUSE	ACTION
Hesitation or flat spot (cold engine) Excessive fuel consumption Lack of power Engine overheating Engine cuts-out or stalls (at idle) Engine 'runs-on' Engine knocks or pinks Rich running (excess CO)	One-way valve faulty	Blow through valve to check 'one way' action. If the valve leaks fit a new valve. 17.30.05.
Poor or erratic idle Hesitation or flat spot (cold engine) Excessive fuel consumption Lack of power Engine overheating Engine cuts-out or stalls (at idle) Engine 'runs-on' Engine knocks or pinks Rich running (excess CO)	Temperature sensor faulty, leaking or jammed	Check and renew if necessary. 17.30.10
Poor or erratic idle Hesitation or flat spot (cold engine) Excessive fuel consumption Lack of power Engine cuts-out or stalls (at idle) Engine misfires Lean running (low CO)	Flap valve diaphragm leaking	Check with a distributor vacuum test unit. If leakage is apparent, renew air cleaner outer cover which includes the servo motor



## ONE-WAY VALVE

Remove and refit 17.30.05

### Removing

- 1 Disconnect the pipe from the one-way valve.
- 2 Remove the one-way valve, complete with union nut, from the brass banjo union.
- 3 Separate the union nut from the valve body taking care not to lose the ball and spring.

### Refitting

- 4 Clean the valve internally and ensure the hole is clear.
- 5 Insert the spring and ball.
- 6 Fit and tighten the union nut.
- 7 Fit the valve assembly to the banjo union using a new fibre washer.
- 8 Reconnect the pipe to the one-way valve.

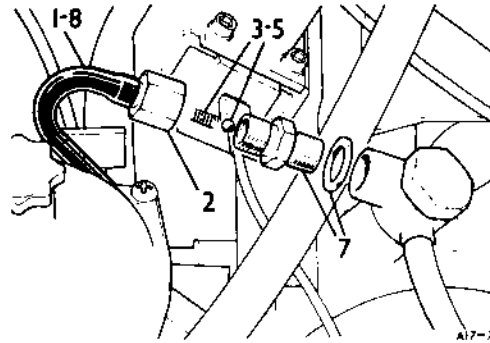

## RUNNING-ON CONTROL VALVE – Canadian and Californian Specification only

Remove and refit 17.40.01

### Removing

- 1 Disconnect the solenoid electrical leads.
- 2 Disconnect the vacuum control pipe.
- 3 Disconnect the canister to run-on valve pipe.
- 4 Twist the valve and withdraw it from its retaining bracket.

### Refitting

- 5 Reverse instructions 1 to 4.

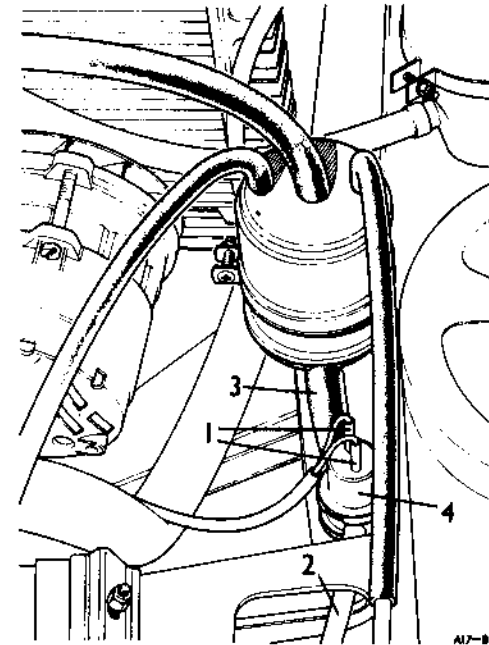

## TEMPERATURE SENSOR UNIT

Remove and refit 17.30.10

### Removing

- 1 Remove the air cleaner, 19.10.08.
- 2 Prise off the clip securing the temperature sensor unit to the air cleaner back-plate.
- 3 Remove the temperature sensor unit.
- 4 Remove the felt washer.

### Refitting

- 5 Fit the felt washer to the sensor unit.
- 6 Fit the sensor unit to the back-plate noting that it can only be fitted in one position.
- 7 Secure the unit with the spring clip.
- 8 Refit the air cleaner, 19.10.08, ensuring that the two vacuum pipes are correctly positioned on the sensor unit i.e.
  - a The pipe from the one-way valve is fitted to the connection closest to the back-plate.
  - b The pipe from the air inlet temperature control unit furthest from the back-plate.

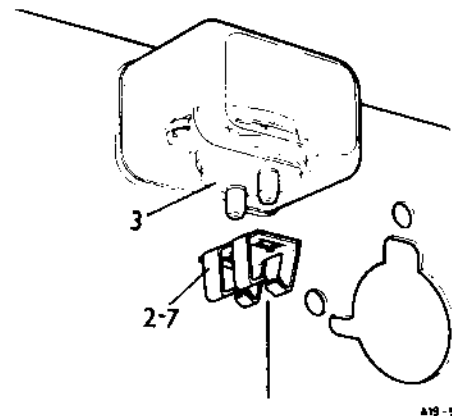

## EXHAUST GAS RECIRCULATION VALVE

Remove and refit 17.45.01

### Removing

- 1 Remove the vacuum pipe.
- 2 Remove the two bolts securing the valve to the manifold location.
- 3 Lift off the valve complete with gasket.

### Refitting

- 4 Clean the valve port and the valve to manifold mating faces.
- 5 Place a new gasket in position ensuring that it is fitted with the correct face towards the manifold i.e. 'MANIFOLD SIDE'.
- 6 Secure the valve with the two bolts and plain washers.
- 7 Connect the vacuum pipe.

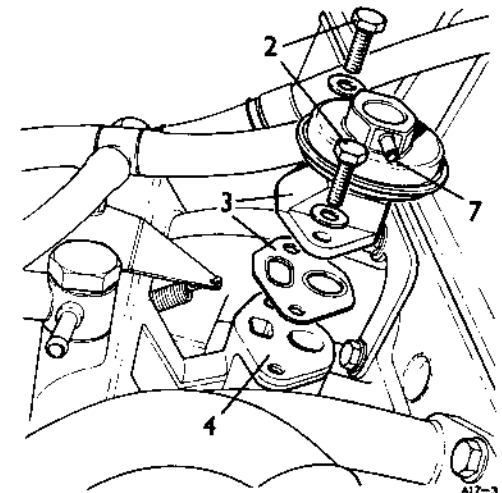

**EXHAUST GAS RECIRCULATION CONTROL VALVE**

Remove and refit 17.45.05

**Removing**

- 1 Disconnect the pipe from the valve.
- 2 Remove the screw and shake proof washer securing the valve bracket to the rear carburetter.
- 3 Remove the bracket and valve complete.

**Refitting**

- 4 Reverse instructions 1 to 3.

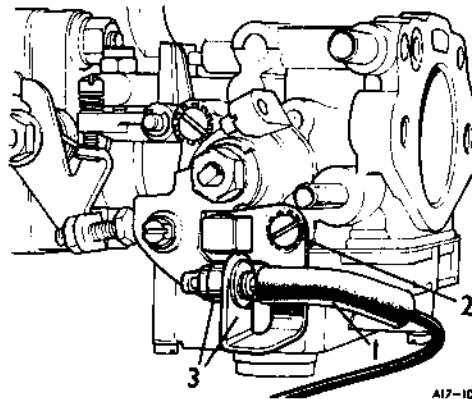
**CATALYTIC CONVERTER**

Remove and refit 17.50.01

**Removing**

- 1 Disconnect the battery and raise the car on a ramp, and allow converter to cool.
- 2 Remove the three nuts and bolts at both ends of the converter.
- 3 Ease converter and extract the olives from the exhaust pipe.
- 4 Withdraw the converter.

**Refitting**

- 5 Position the olives in the down-pipe and main pipe.
- 6 Ease the two pipes apart and insert the catalyst converter ensuring that the deflection plate is facing towards the front of the car.
- 7 Secure the converter with three nuts and bolts at both ends of the converter.
- 8 Lower the ramp and reconnect the battery.

## AIR CLEANER

Remove and refit 19.10.01

### Removing

- 1 Disconnect the two air inlet hoses from the front of the air cleaner.
- 2 Disconnect the engine dipstick support from the air cleaner.
- 3 Slacken the nut securing the throttle linkage bracket to the air cleaner.
- 4 Release the two air cleaner cover clips and remove the cover.
- 5 Withdraw the filter element.
- 6 Remove the six bolts and spring washers (three each carburetter) securing the air cleaner body to the carburetters.
- 7 Remove the air cleaner body and gaskets.

### Refitting

- 8 Offer up the air cleaner body to the carburetters ensuring that the rear support lug engages the throttle bracket bolt and that the carburetter flange gaskets are correctly positioned.

- 9 Fit the six securing bolts and spring washers to the carburetter flanges.
- 10 Tighten the nut securing the throttle bracket to the air cleaner body.
- 11 Install the filter element (metal frame to carburetters).
- 12 Fit the cover and secure with the two clips.
- 13 Fit the air inlet pipes.
- 14 Attach the dipstick guide to the cover.

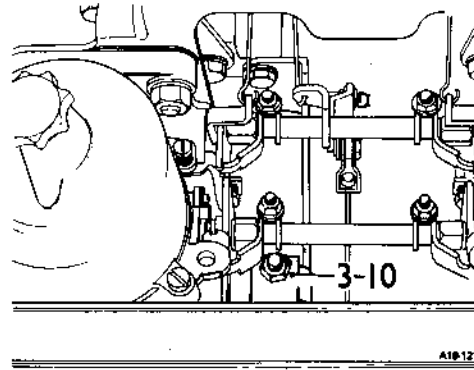

## AIR CLEANER

Renew element 19.10.08

- 1 Disconnect the two air inlet pipes.
- 2 Remove the screw and nut securing the engine dipstick to the filter cover.
- 3 Release the two filter cover clips and remove the cover.
- 4 Withdraw the filter element.
- 5 Thoroughly clean interior of filter body and cover.
- 6 Install new filter element (metal frame to carburetters).
- 7 Fit the cover.
- 8 Fit the air inlet pipes.
- 9 Secure the dipstick clip to the cover.

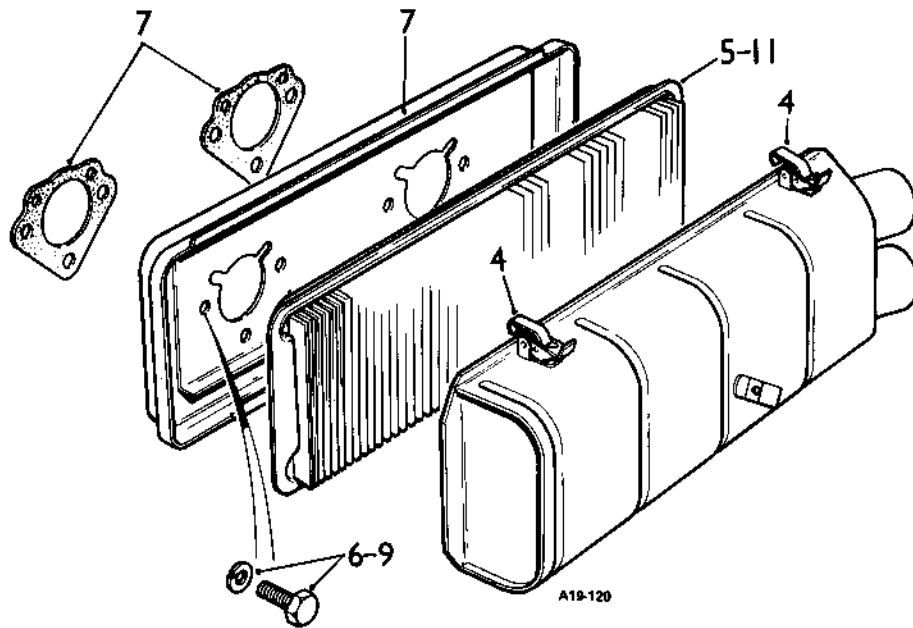
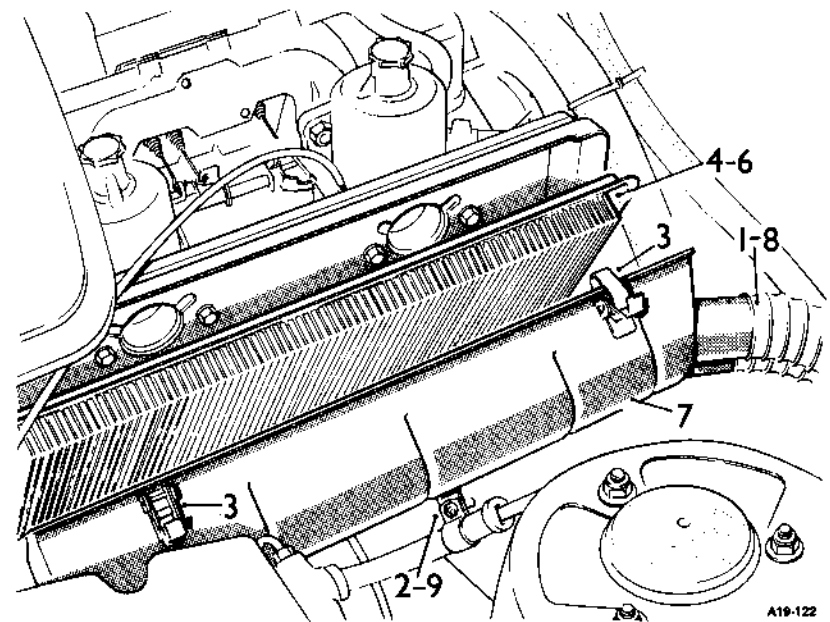

**CARBURETTERS (TWIN SU INSTALLATION)**

**Tune and adjust 19.15.02**

- 1 Remove the air cleaner, see 19.10.02.
- 2 Check the throttle for correct operation ensuring that it does not stick.
- 3 Turn the fast idle adjusting screws anti-clockwise until well clear of the cams, and disconnect the mixture control cable at the trunnion.
- 4 Turn the throttle adjusting screws until just clear of the throttle levers with the throttles closed, then turn the screws 1½ turns clockwise.
- 5 Raise the piston of each carburetter in turn (use the lifting pin if fitted) and check that it falls freely onto the carburetter bridge. If either piston shows any tendency to stick, remove and clean the piston and suction chamber, see 19.15.30.
- 6 Lift and support the piston clear of the carburetter bridge so that the jet is visible.
- 7 Turn the jet adjusting nuts to bring the jets flush with the carburetter bridge.
- 8 Check that the needle shank is flush with the underside of the piston.

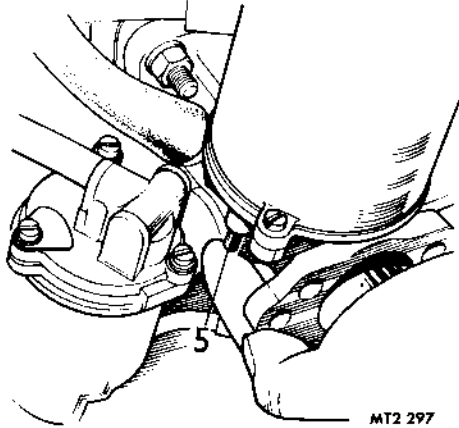
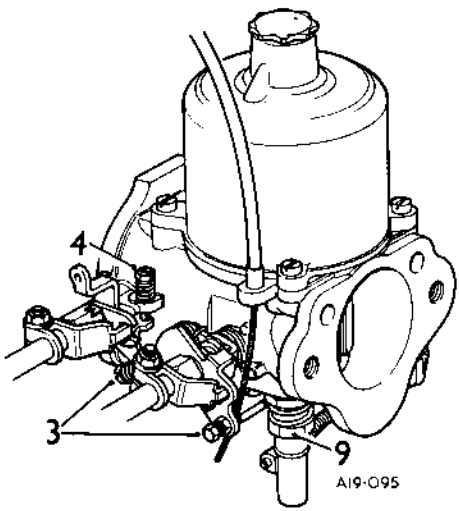

- 9 Turn the jet adjusting nuts down two turns.
- 10 Check the piston damper oil level as follows:
  - a Unscrew the cap and withdraw the damper.
  - b Top-up the hollow piston rod with S.A.E. 20 oil until the level is ½ in (13 mm) above the top of the hollow piston rod - dimension A.

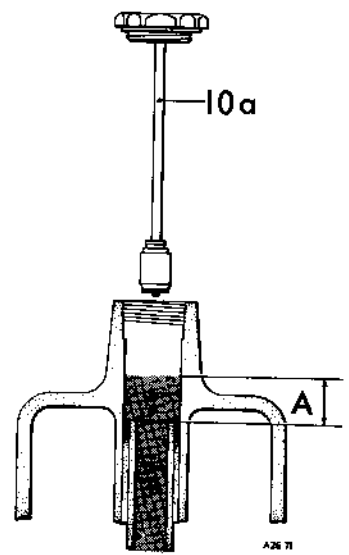

- 11 Start the engine and run at a fast idle speed until it attains normal running temperature and continue for a further five minutes.
- 12 Increase the engine speed to 2500 r.p.m. for thirty seconds.
- 13 Using an exhaust gas analyser insert the probe into the exhaust pipe in accordance with the manufacturers instructions.
 

**NOTE:** Tuning can now commence, but if adjustments cannot be achieved within three minutes increase the engine speed to 2500 r.p.m. and then continue. Repeat this clearing procedure at three minute intervals until tuning is complete.

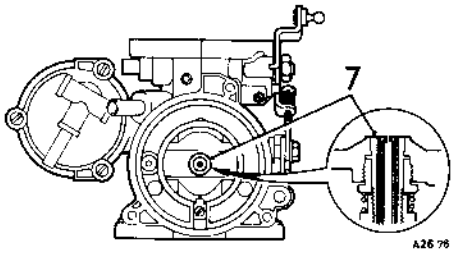
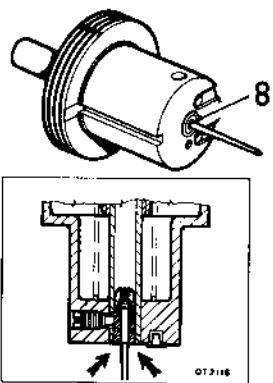
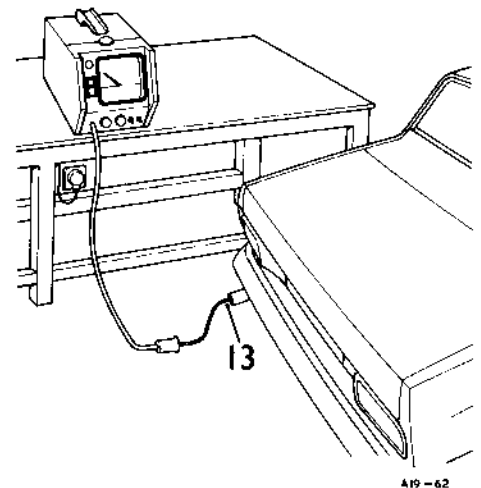

- 14 Slacken both clamping nuts and bolts on the throttle spindle interconnections.
- 15 Slacken both nuts and bolts on the jet control interconnections.
- 16 Using a balancing meter check the carburetters for balance and adjust by turning the throttle adjusting screws whilst maintaining the correct idling speed – see DATA.
- 17 Turn the jet adjusting nut on each carburetter down to enrich or up to weaken the mixture by the same amount until the fastest speed is indicated on the tachometer.
- 18 Turn each adjusting nut up one flat at a time until the engine speed just commences to fall.
- 19 Turn the adjusting nuts down by the minimum amount until the fastest speed is regained.
- 20 Check the idle speed and adjust if necessary by turning the throttle adjusting screws by the same amount.
- 21 Check that the CO reading on the exhaust gas analyser is within the accepted limits at idling, see DATA.

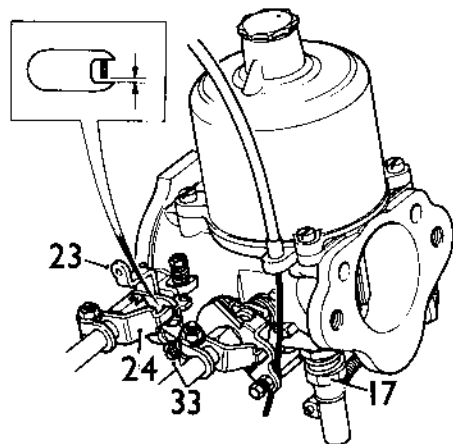

A19-90

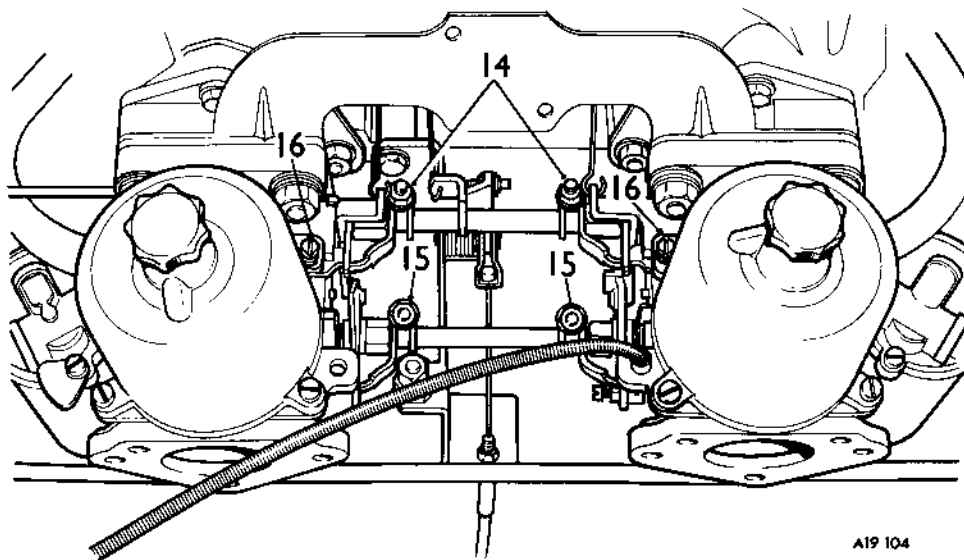

A19 104

- 22 If the CO reading falls outside the limits, reset both jet adjusting nuts by the minimum amount necessary.

**NOTE:** If an adjustment exceeding three flats or half a turn is required to achieve this the carburetters must be removed and overhauled.

**Automatic kick-down**

- 34 Where applicable, adjust the kick-down cable so that there is no slack, but that a gap of 0.020 to 0.025 in (0.50 to 0.63 mm) exists between the ferrule and the cable adjuster.
- 35 Fit the air cleaner, see 19.10.02.

**Throttle and mixture control linkage setting**

- 23 Hold the throttle lever against its stop.
- 24 Rotate the lever pins on the throttle interconnection shaft until a gap of 0.010 in (0.25 mm) exists between the pins and the lower arm of the forks.
- 25 Ensure that the link rod is at the top of the elongated hole in throttle shaft actuating lever.
- 26 Whilst maintaining the positions in instructions 24 and 25 tighten the lever pin clamping nuts and bolts on both carburetters.
- 27 Adjust the throttle cable to take-up any slack.
- 28 Check and if necessary adjust the accelerator pedal stop to ensure full throttle opening.
- 29 Using the balancing meter re-check the carburetters for balance by running the engine at 1500 r.p.m.
- 30 With the fast idle cams against their respective stops tighten the jet control interconnection clamps, so that both cams begin to move simultaneously.
- 31 Connect the mixture control cable to the trunnion and ensure that there exists a  $\frac{1}{8}$  in (1.5 mm) free movement of the cable before the cams move.
- 32 Pull out the mixture control knob until the linkage is about to move the jet.
- 33 Using the balancing meter to ensure equal adjustment turn the fast idle adjusting screws to give the correct fast idle speed – see DATA – and tighten the lock nuts.

**DATA**

Idling speed . . . . .	650 to 850 r.p.m.
Fast idling speed . . . . .	1100 to 1300 r.p.m.
CO level at idling speed . . . . .	2.0 to 4.5%

**CARBURETTERS**

Remove and refit

19.15.11

**Removing**

- 1 Disconnect the battery.
- 2 Remove the air cleaner complete, see 19.10.01.
- 3 Remove the fresh air duct.
- 4 Disconnect the mixture control cable from the front carburetter.
- 5 Pull-off the fuel over-flow pipes from the front and rear float chambers.
- 6 Pull-off the vacuum pipe from the rear carburetter to the distributor advance capsule.
- 7 Disconnect the engine breather pipes from the carburetters.
- 8 Disconnect the fuel feed pipes to the carburetters.
- 9 Disconnect the vertical link from the throttle interconnection shaft.
- 10 Disconnect the three throttle shaft return springs.
- 11 Remove the eight (four per carburetter) nuts, plain and spring washers securing the carburetters to the inlet manifold.
- 12 Withdraw the carburetters complete.
- 13 Remove and discard the gaskets.

**Refitting**

- 14 Clean the carburetter and flexible mounting mating faces and fit new gaskets.
- 15 Fit the carburetters ensuring that the mixture control pins are located in their respective forks.
- 16 Fit the plain and spring washers and evenly tighten, to the correct torque, the eight retaining nuts.
- 17 Reverse instructions 1 to 10.
- 18 Tune and adjust the carburetters, see 19.15.02.

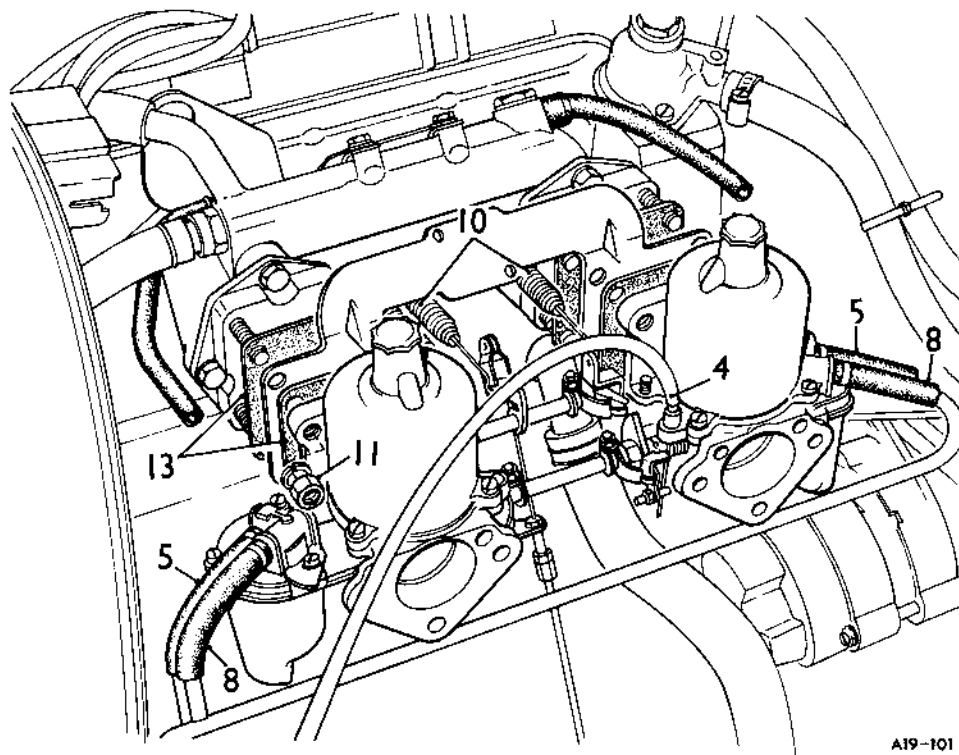

A19-101

## CARBURETTERS (TWIN SU INSTALLATION)

Overhaul and adjust

19.15.17

### Dismantling

- 1 Remove the carburetter assembly, see 19.15.11.
- 2 Thoroughly clean the outside of the carburetter.
- 3 Mark the suction chamber to ensure it is refitted to the same body.
- 4 Remove the damper and its washer.
- 5 Unscrew the suction chamber securing screws and lift off the chamber.
- 6 Remove the piston spring.
- 7 Carefully lift out the piston assembly and empty the oil from the piston rod.
- 8 Remove the guide locking screw and withdraw the needle assembly, taking care not to bend the needle. Withdraw the needle from the guide and remove the spring from the needle.
- 9 Where fitted, push the piston lifting pin upwards, detach its securing circlip and washers and withdraw the pin and spring downwards.
- 10 Release the pick-up lever return spring from its retaining lug.
- 11 Support the plastic moulded base of the jet and remove the screw retaining the jet pick-up link and link bracket.
- 12 Unscrew the flexible jet tube sleeve nut from the float-chamber and withdraw the jet assembly. Note the gland, washer and ferrule at the end of the jet tube.
- 13 Remove the jet adjusting nut and spring.
- 14 Unscrew the jet locking nut and detach the nut and jet bearing; withdraw the bearing from the nut.
- 15 Unscrew and remove the lever pivot bolt and spacer.
- 16 Detach the lever assembly and return springs, noting the pivot bolt tubes and the location of the cam and pick-up lever springs.
- 17 Unscrew the securing bolt and remove the float chamber and spacer.
- 18 Mark the float chamber lid location.
- 19 Remove the lid securing screws and detach the lid with its joint washer and float. Retain the part number tag.

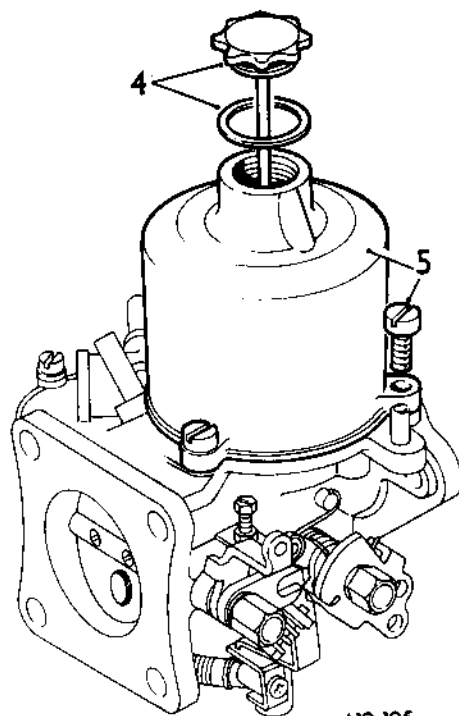

A19-105

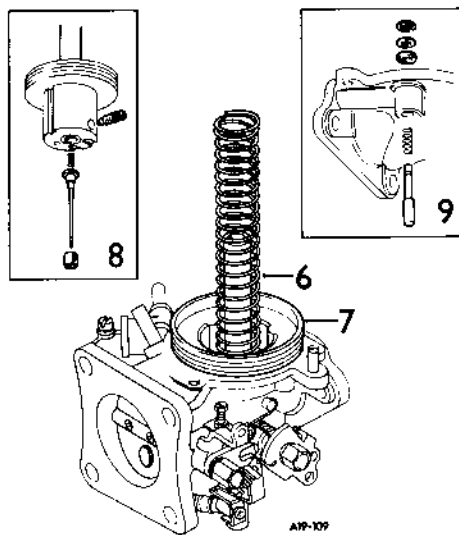

A19-109

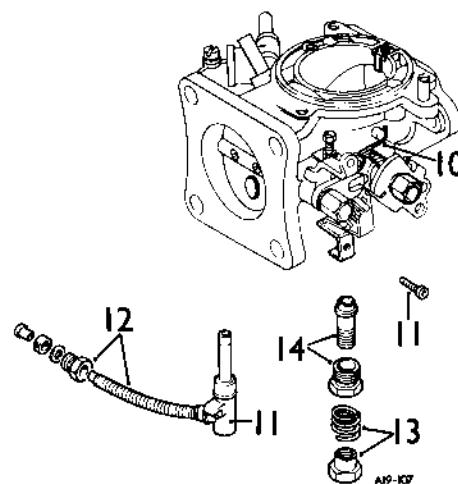

- 20 Hold the float hinge pin at its serrated end and withdraw the pin and float.
- 21 Extract the float needle from its seating and unscrew the seating from the lid.
- 22 Close the throttle and mark the relative position of the throttle disc and the carburetter flange.
- 23 Press the split ends of the disc retaining screws together and remove the screws. Open the throttle and remove the disc from its slot in the throttle spindle.

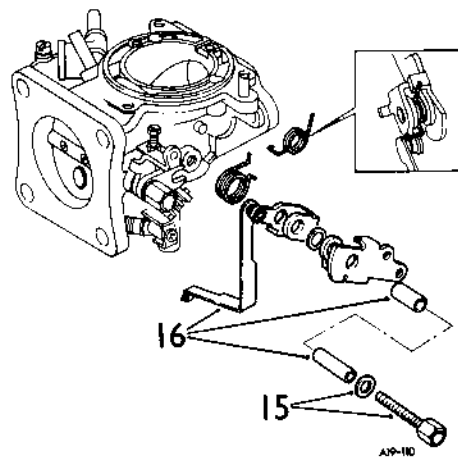

A19-110

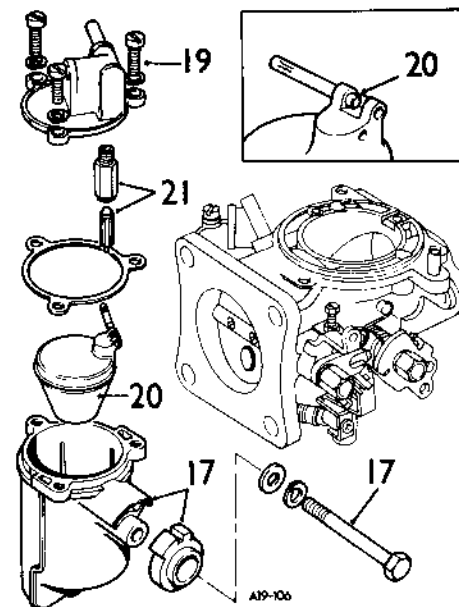

- 24 Release the lock washer tabs securing the spindle nut; remove the nut and detach the fork lever, lever arm, washer and throttle spindle; note the location of the lever arm in relation to the spindle and carburetter body.

continued

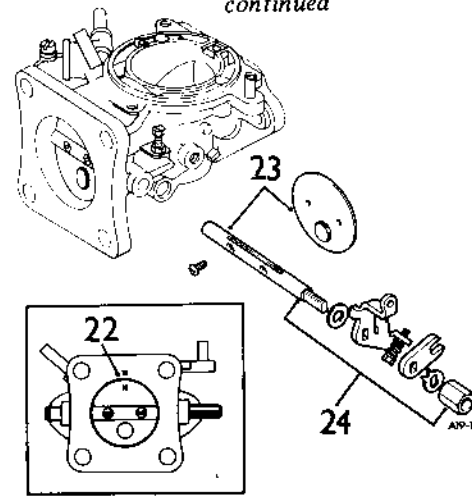

A19-112

**Inspecting**

- 25 Examine the components as follows:
- a Check the throttle spindle in the body for excessive play, and renew if necessary.
  - b Examine the float needle for wear; i.e. small ridges or grooves in the seat of the needle, and ensure that the spring-loaded plunger on the opposite end operates freely. Replace the needle and seating if necessary.
  - c Inspect all other components for wear and damage; renew unserviceable components.

- 30 Screw the seating into the float chamber lid; do not overtighten. Insert the needle coned-end first into the seating.
- 31 Refit the float to the chamber lid and insert the hinge pin.
- 32 Refit the float chamber lid with a new joint washer, noting the assembly markings, tighten the securing screws evenly.

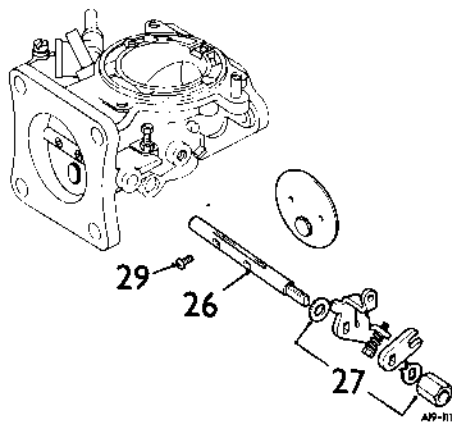

**Reassembling**

- 26 Refit the spindle to the body, with the countersunk holes in the spindle facing outwards.
- 27 Assemble the spacing washer, lever, fork lever, lock washer and securing nut, ensure that the idling stop on the lever is against the idling screw abutment on the body in the closed throttle position. Tighten the spindle nut and lock with tab washer.
- 28 Insert the throttle disc into the spindle slot; not the markings for reassembling. Manoeuvre the disc in the spindle until the throttle can be closed, snap the throttle open and closed to centralize it in the bore of the carburetter.
- 29 Fit new disc retaining screws but do not fully tighten, check that the disc closes fully and adjust its position as necessary. Tighten the screws fully and spread their split ends just enough to prevent them turning.

- 33 Refit the float chamber to the body and tighten the retaining bolt.
- 34 Where fitted, refit the piston lifting pin, spring and circlip.
- 35 Clean fuel deposits off the suction chamber and piston with fuel or methylated spirit and wipe dry.

**CAUTION:** Do not use an abrasive.

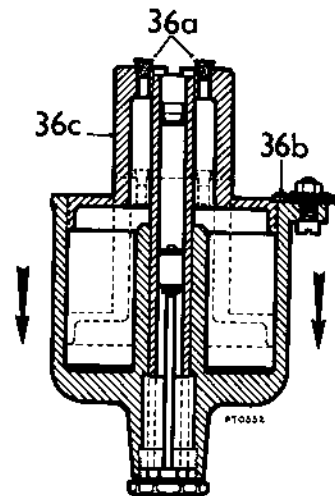
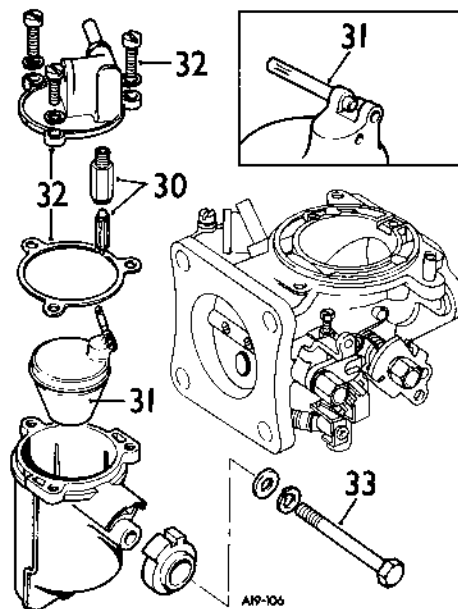

- 36 Check the operation of the suction chamber and piston (without the spring fitted) as follows:
- a Refit the damper and washer to the suction chamber; temporarily plug the piston transfer holes with rubber plugs or Plasticine and insert the piston fully into the suction chamber.
  - b Secure a large flat washer to one of the fixing holes with a screw and nut so that it overlaps the bore.
  - c With the assembly upside-down, hold the piston and check the time taken for the suction chamber to fall the full extent of its travel. The time taken should be five to seven seconds; if this time is exceeded, check the piston and chamber for cleanliness and mechanical damage. Renew the assembly if the time taken is still not within these limits.

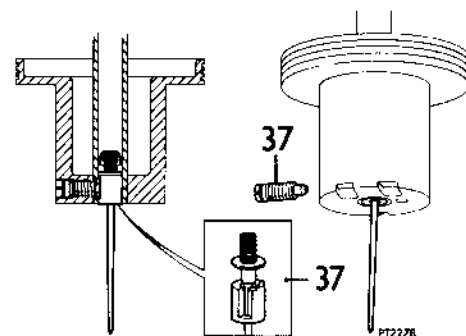

- 37 Fit the spring and guide to the needle and insert the assembly into the piston (with the shoulder of the needle flush with the underside face of the piston) and the slot in the guide positioned adjacent to the needle guide locking screw. Fit a new guide locking screw.



- 38 Check the piston key in the body for security.
- 39 Refit the jet bearing; fit and tighten the jet locking nut.
- 40 Refit the spring and jet adjustment nut; screw the nut up as far as possible.
- 41 Insert the jet into the bearing, fit the sleeve nut, washer and gland to the end of the flexible tube (if removed). The tube must project a minimum of  $\frac{3}{8}$  in (4.8 mm) beyond the gland. Tighten the sleeve nut until the gland is compressed; over-tightening can cause leakage.
- 42 Refit the piston, spring and suction chamber to the body (noting the assembly marks) and tighten the securing screws evenly.
- 43 Reverse the procedure in 15 and 16.
- 44 Hold up the choke lever to relieve pressure on the jet pick-up link, refit the link bracket; support the end of the moulded jet and tighten the securing screw.

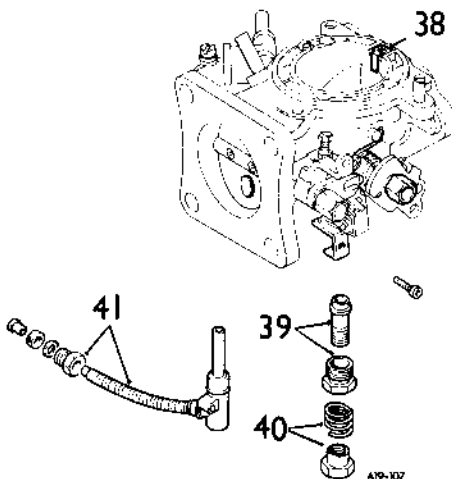

## CARBURETTER FLEXIBLE MOUNTINGS

Remove and refit 19.15.19.

### Removing

- 1 Remove the air cleaner, see 19.10.01.
- 2 Remove the carburetters, see 19.15.11.
- 3 Remove the six bolts (three per manifold) securing the mountings to the intakes.
- 4 Remove the mountings.

### Refitting

- 5 Clean the manifold intake and flexible mounting faces and secure the mounting with the bolts and spring washers.
- 6 Fit the carburetters and tune, see 19.15.11.
- 7 Fit the air cleaner, see 19.10.01.

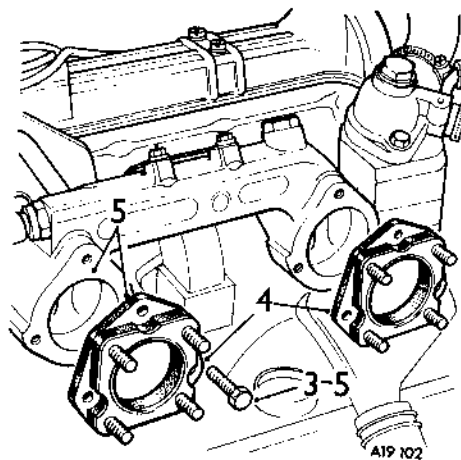

## FLOAT CHAMBER NEEDLE AND SEAT

Remove and refit 19.15.24

### Removing

- 1 Remove the fresh air duct for rear carburetter, see 80.15.31.
- 2 Disconnect the fuel over-flow pipe.
- 3 Disconnect the fuel feed pipe to the float chamber.
- 4 Disconnect the breather hose from the carburetter.
- 5 Mark the lid and float-chamber for assembly.
- 6 Remove the lid securing screws and detach the lid.
- 7 Hold the float hinge pin at its serrated end and withdraw the pin and float.
- 8 Extract the float needle from its seating.

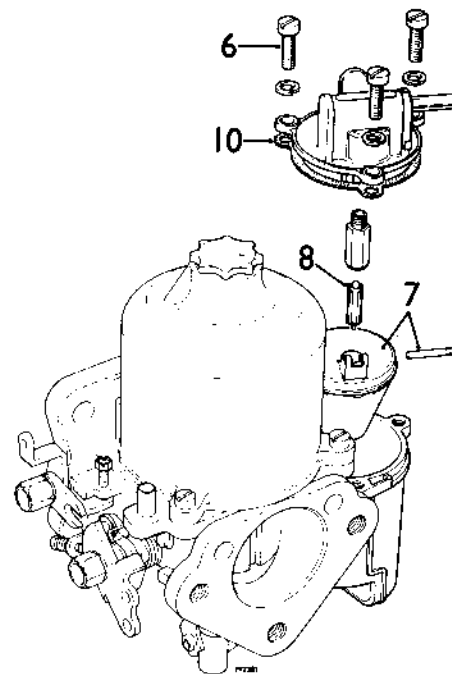

### Inspecting

- 9 Examine the float needle for wear, i.e. small ridges or grooves in the seat of the needle, also check that the spring-loaded plunger on the opposite end operates freely. Renew the needle and seating if the needle is worn.

### Refitting

- 10 Clean any sediment from the float-chamber, and fit a new joint washer if required.
- 11 Reverse instructions 1 to 9.

## PISTON AND SUCTION CHAMBER (SU CARBURETTER)

Remove, clean and refit 19.15.30

### Removing

- 1 Remove the fresh air duct—for rear carburetter only, see 80.15.31.
- 2 Mark the relative position of the suction chamber and the carburetter body.
- 3 Remove the damper and its washer.
- 4 Unscrew the suction chamber securing screws and lift off the chamber.

*continued*

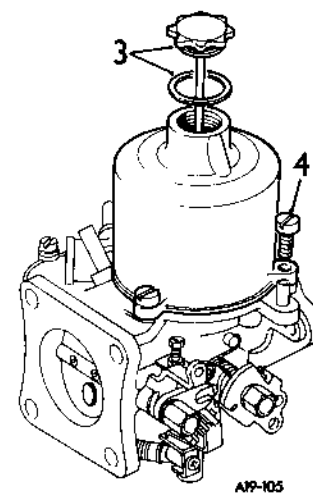

- 45 Screw the jet adjusting nut down two complete turns (12 flats) to provide the initial setting.
- 46 Refit the carburetters, see 19.15.11.
- 47 Tune and adjust the carburetters, see 19.15.02.

- 5 Remove the piston spring.  
 6 Carefully lift out the piston assembly and empty the oil from the piston rod.  
 7 Clean fuel deposits off the suction chamber and piston with fuel or methylated spirit and wipe dry.

**CAUTION:** Do not use abrasives.

- 8 Check the operation of the suction chamber and piston (without the spring fitted) as follows:
- Refit the damper and washer to the suction chamber, temporarily plug the piston transfer holes with rubber plugs or Plasticine and insert the piston fully into the suction chamber.
  - Secure a large flat washer to one of the fixing holes with a screw and nut so that it overlaps the bore.
  - With the assembly upside-down, hold the piston and check the time taken for the suction chamber to fall the full extent of its travel. The time taken should be five to seven seconds, if this time is exceeded, check the piston and chamber for cleanliness and mechanical damage. Renew the assembly if the time taken is still not within these limits.

#### Refitting

- 9 Refit the piston, spring and suction chamber to the carburettor (noting the assembly marks) and tighten the screw evenly.  
 10 Top up each piston damper with a recommended engine oil until the level is  $\frac{1}{2}$  in (13 mm) above the top of the hollow piston rod.  
 11 Refit each piston damper with its washer.

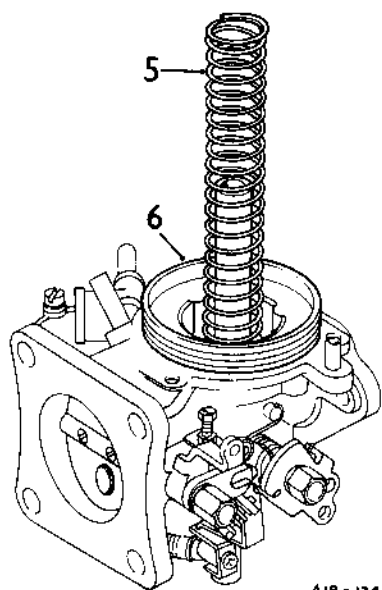

A19-124

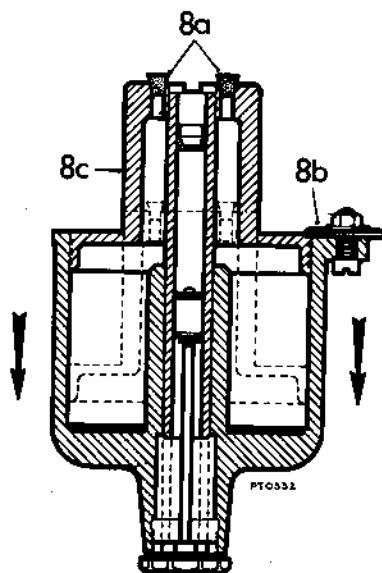

PT0332

## THROTTLE PEDAL ASSEMBLY

Remove and refit 19.20.01

### Removing

- Disconnect the battery.
- Working from inside the car remove the spring clip securing the throttle cable.
- Remove the cable from the pedal.
- Open the bonnet and remove the two bolts securing the pedal assembly to the bulkhead.
- Remove the pedal assembly from the car.
- Strip the pedal assembly, and discard worn parts.

### Refitting

- Locate the spring in the bracket.
- Fit the pedal to the bracket.
- Insert the clevis pin.
- Fit the anti-rattle washer.
- Fit the plain washer.
- Secure the assembly with a new split pin.
- Fit the pedal to the bulkhead and secure with the two bolts.
- Fit the cable to the pedal and retain with the spring clip.
- Re-connect the battery.

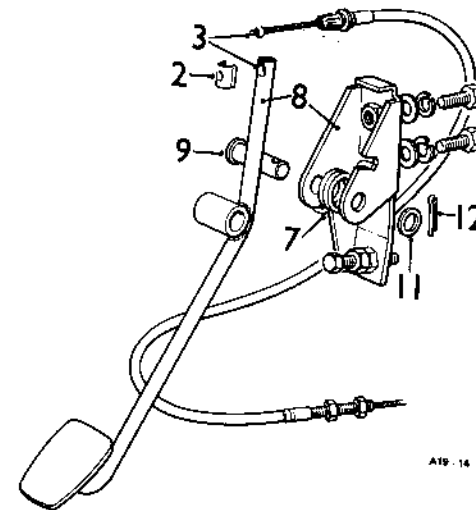

A19-14

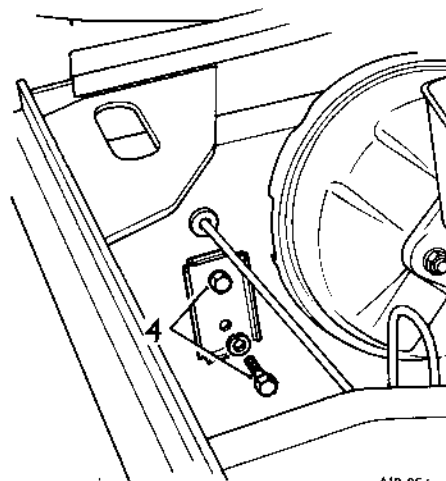

A19 054

## MIXTURE CONTROL CABLE ASSEMBLY

Remove and refit 19.20.13  
 Inner cable — instructions 19.20.14  
 1 to 2

### Removing

- 1 Disconnect the exposed inner cable from the carburettor trunnion.
- 2 Working inside the car, pull the mixture control knob and withdraw the inner cable complete.
- 3 Pull-off the choke indicator Lucar from the switch.
- 4 Slacken the outer cable retaining nut.
- 5 Unscrew the bezel from the outer cable.
- 6 Remove the outer cable complete from the bracket and car.
- 7 Slacken the grub screw and remove the choke indicator switch from the cable.

### Refitting

- 8 Reverse instructions 1 to 7 ensuring that the choke indicator switch is fitted correctly, see 86.65.53.

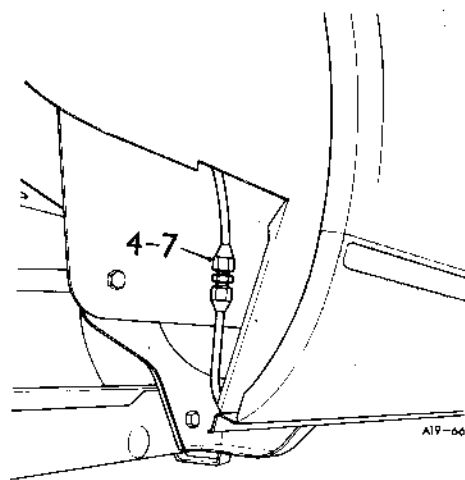
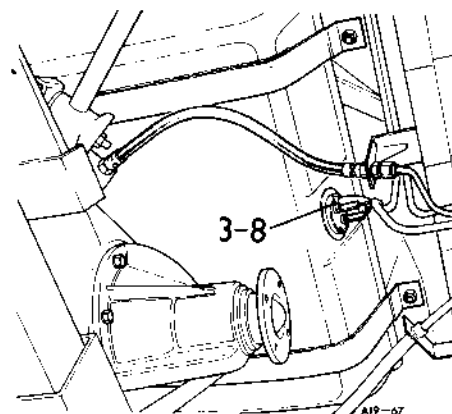
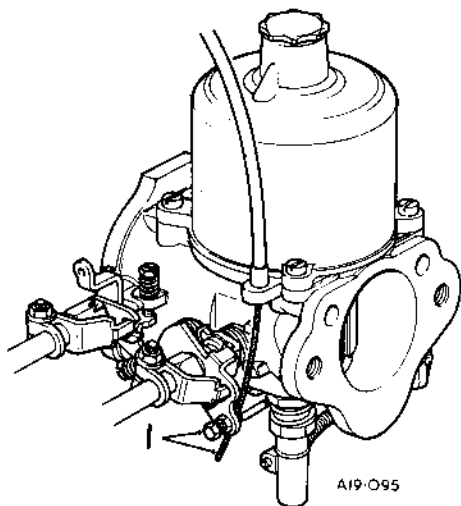

- 4 Pull off the rubber hose connecting engine-end section to the fuel pump.
- 5 Remove the pipe from the retaining clips.

### Refitting

- 6 Reverse instructions 3 to 5.
- 7 Start the engine and check for leaks.
- 8 Stop the engine and lower the ramp.

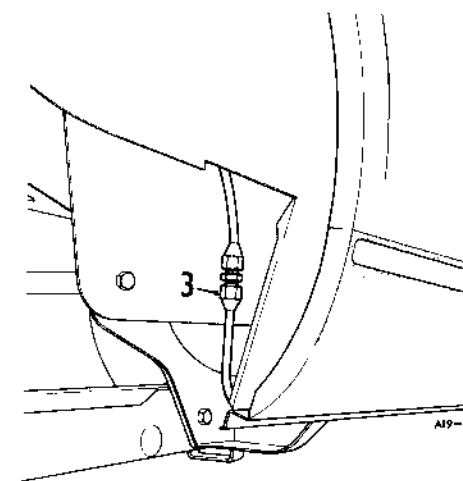
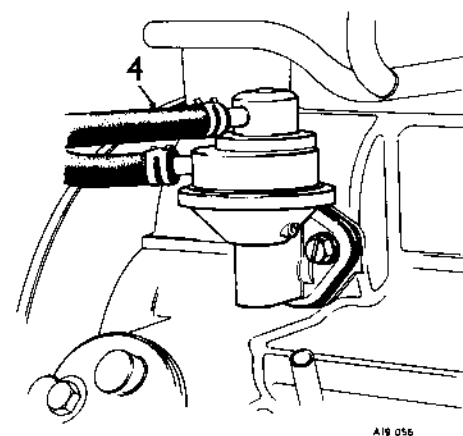

## PETROL PIPE — MAIN LINE — TANK END SECTION

Remove and refit 19.40.02

### Removing

- 1 Drive the car on to a ramp and raise.
- 2 Drain the petrol tank.
- 3 Pull off the rubber connection from the tank.
- 4 Release the tank-end section from the engine-end section at the union (right-hand rear wing).
- 5 Release the pipe from the retaining clips and remove from the car.

### Refitting

- 6 Clip the pipe into position.
- 7 Connect the pipe to the engine-end section at the union.
- 8 Connect the pipe to the tank with the rubber connector.
- 9 Lower the ramp and refill the tank.

## PETROL PIPE — MAIN LINE — ENGINE END SECTION

Remove and refit 19.40.04

### Removing

- 1 Drive the car onto a ramp.
- 2 Raise the ramp and drain the petrol tank.
- 3 Disconnect the engine-end section from the petrol tank-end section at the union (right-hand wing).

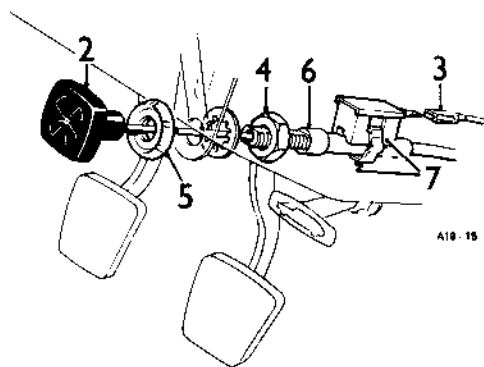

**HOSE - FILLER TO TANK****Remove and refit** 19.40.19**Removing**

- 1 Open the boot and remove the access panel.
- 2 Remove the filler cap assembly, see 19.55.08.
- 3 Release the hose clip securing the filler hose to the fuel tank, visible through the access aperture.
- 4 Pull off the filler hose.

**Refitting**

- 5 Fit the filler hose to the tank and secure with the hose clip.
- 6 Fit the fuel filler cap assembly - instructions 7 to 10, see 19.55.08.
- 7 Fit the access panel.

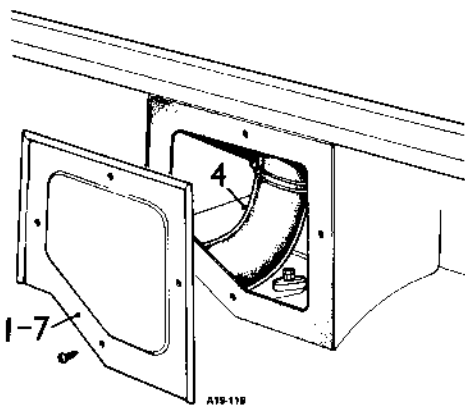
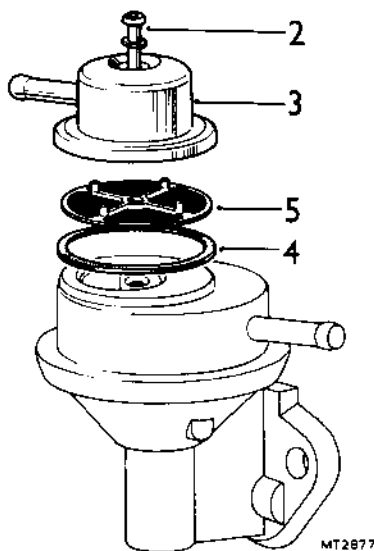
**FUEL PUMP****Clean filter** 19.45.05

- 1 Remove the fresh air duct, see 80.15.31.
- 2 Remove the pump cover retaining screw using a long shafted screw driver.
- 3 Lift-off the cover.
- 4 Remove the sealing ring.
- 5 Lift out the filter.
- 6 Clean sediment from the cover.
- 7 Clean and examine the filter and refit.
- 8 Fit a new sealing ring - if necessary.
- 9 Fit the cover and secure it with the screw and a new washer.

**FUEL PUMP****Remove and refit** 19.45.08**Removing**

- 1 Remove the air cleaner outer cover and element.
- 2 Disconnect the pipe from the fuel tank to the pump inlet connection.
- 3 Disconnect the outlet pipe from the pump.
- 4 Remove the bolts securing the pump to the cylinder block.
- 5 Remove the pump.
- 6 Remove the gasket.

**Refitting**

- 7 Clean the pump and cylinder block mating faces.
- 8 Fit a new gasket.
- 9 Fit the pump ensuring that the actuating arm rides on top of the cam.
- 10 Fit and tighten the retaining nuts and spring washers.
- 11 Fit the fuel inlet and outlet pipes.

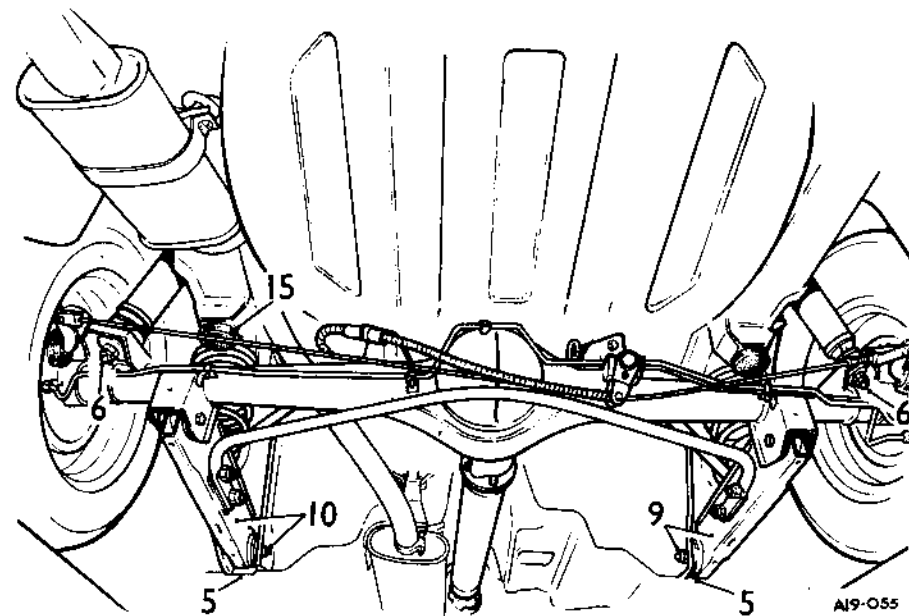
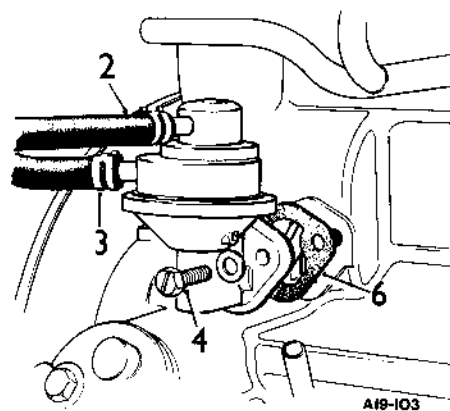
**FUEL TANK****Remove and refit** 19.55.01**Removing**

- 1 Drive the car onto a ramp and disconnect the battery.
- 2 Remove the fuel filler cap assembly, see 19.55.08.
- 3 Raise the ramp and unclip the fuel tank breather hose from the LH side of the rear chassis member.
- 4 Drain the fuel tank.
- 5 Support the body with jacks both sides of the car forward of the trailing arm attachment points.
- 6 Disconnect the dampers at their lower attachment to the axle.
- 7 Disconnect the tank unit electrical leads.
- 8 Pull off the rubber connection to the main fuel line.
- 9 Disconnect the R.H. radius rod from the body bracket.
- 10 Remove the L.H. radius rod from the car.

11 Jack up the body sufficiently to remove both road springs.

**CAUTION:** Care must be taken to ensure that whilst jacking up the body the brake hydraulic system jump hose is not stretched—shown arrowed.

12 Remove the L.H. rear road wheel and allow the axle to drop having regard for the above cautionary note.

13 Support the axle with a jack to relieve any tension in the hydraulic jump hose.

14 Remove the tail pipe and silencer assembly, see 30.10.22.

15 Remove the L.H. bump stop.

16 Remove the four nuts and tank retaining straps.

17 Withdraw the tank from the L.H. side of the car.

18 Remove the filler hose.

19 Remove the breather hose.

20 Remove the tank unit, see 88.25.32 instructions 6 to 8.

**NOTE:** Instructions 18 to 20 are only necessary if the tank is to be renewed.

#### Refitting

**NOTE:** If the tank is not being renewed ignore instructions 18 to 22. However, renew all hoses if any deterioration exists.

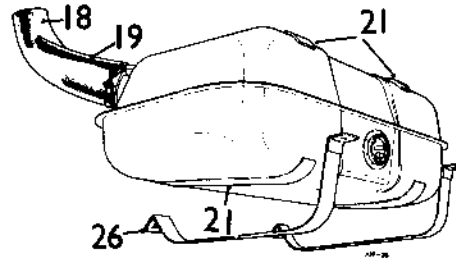
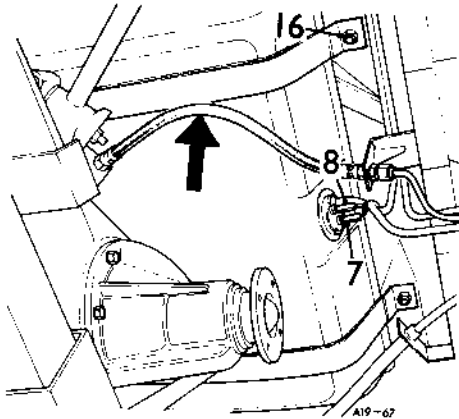

21 Using adhesive fit new cushion strips to the tank noting that thicker strips are fitted to the top of the tank.

22 Fit the filler hose.

23 Fit the breather hose.

24 Fit the tank unit — reversing instructions 6 to 8, see 88.25.32.

25 Manoeuvre the tank into position from the L.H. side of the car.

26 Fit the supporting straps noting that the elongated holes in the straps are fitted to the rear studs in the body.

27 Fit and tighten the four retaining nuts.

28 Fit the L.H. radius rod to the axle—including the handbrake cable bracket—leaving the body-end free for the time being.

29 Fit the springs and jack-up the axle both sides and connect the dampers to their axle locations.

30 Fit the L.H. bump stop.

31 Fit the L.H. and R.H. radius rods to their body locations.

32 Fit the tail pipe and silencer assembly, see 30.10.22.

33 Fit the L.H. rear road wheel.

34 Lower and remove the body and axle jacks.

35 Connect the fuel tank to the main line pipe with the rubber connector.

36 Fit the electrical leads to the tank unit—instruction 10, see 88.25.32.

37 Fit the breather pipe.

38 Lower the ramp and fit the fuel filler assembly, see 19.55.08 instructions 7 to 10.

39 Fit the access panel.

40 Refill the fuel tank, connect the battery, start the engine and check for leaks.

## FUEL FILLER CAP AND FILLER ASSEMBLY

Remove and refit 19.55.08

### Removing

1 Turn the fuel filler cap anti-clockwise and withdraw.

2 Remove the three screws securing the filler tube assembly to the body.

3 Open the boot and remove the access panel—four screws.

4 Slacken the top hose clip.

5 Withdraw the filler tube.

6 Remove the finisher.

### Refitting

7 Place the finisher in position.

8 Insert the filler tube into the filler hose and secure with the three screws.

9 Refit the filler cap.

10 Tighten the filler hose top clip.

11 Refit the access panel and close the boot.

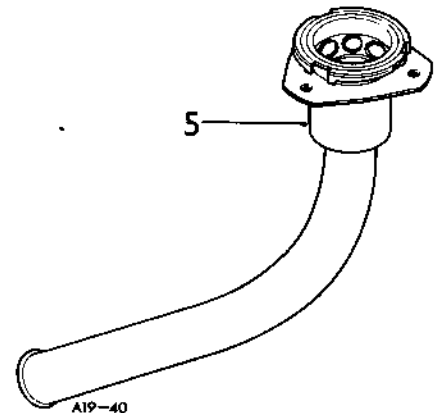
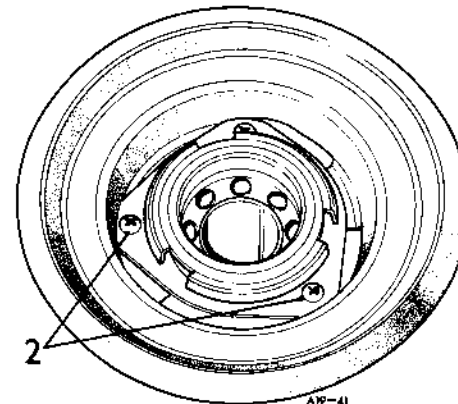
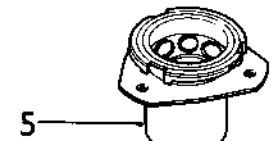
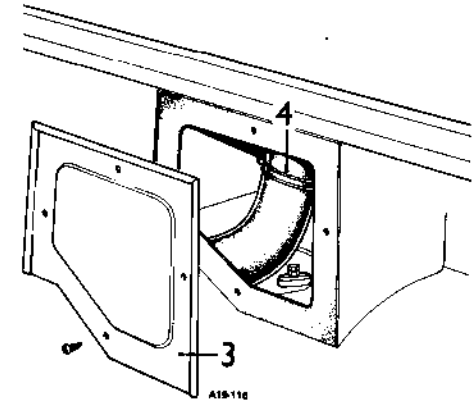

## AIR CLEANER

Remove and refit 19.10.01

### Removing

- 1 Disconnect the hot air pipe from the air cleaner.
- 2 Remove the vacuum pipe from air inlet temperature control unit.
- 3 Release the two retaining clips.
- 4 Separate the air cleaner outer cover from the backplate and withdraw the element.
- 5 Remove the outer cover.
- 6 Remove the two fuel traps from the clips.
- 7 Disconnect the vacuum pipe from the temperature sensor unit.
- 8 Remove the single retaining nut behind the back-plate.
- 9 Remove the six bolts securing the back-plate to the carburettor intakes.
- 10 Withdraw the back-plate complete with gaskets.

### Refitting

- 11 Using new gaskets reverse instructions 1 to 10.

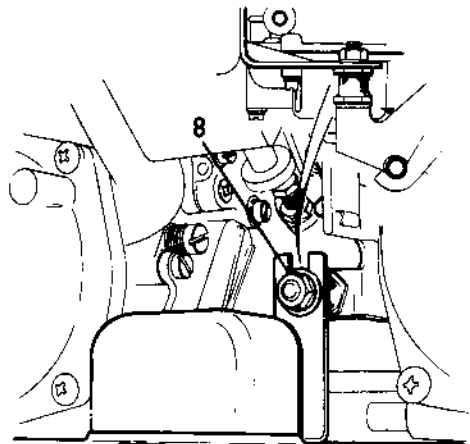

A19-52

## AIR CLEANER

Renew element 19.10.08

- 1 Disconnect the hot air pipe from the air cleaner.
- 2 Release the two retaining clips and hinge back the outer cover from the back-plate.
- 3 Withdraw the air cleaner element.
- 4 Clean the inside of the box and insert a new element noting that it is fitted with the rubber seal towards the engine.
- 5 Hinge forward the outer cover and secure with the two clips.
- 6 Connect the hot air pipe.
- 7 Check that the vacuum pipe is connected to the temperature sensor unit at one end and the air inlet temperature control unit at the other.

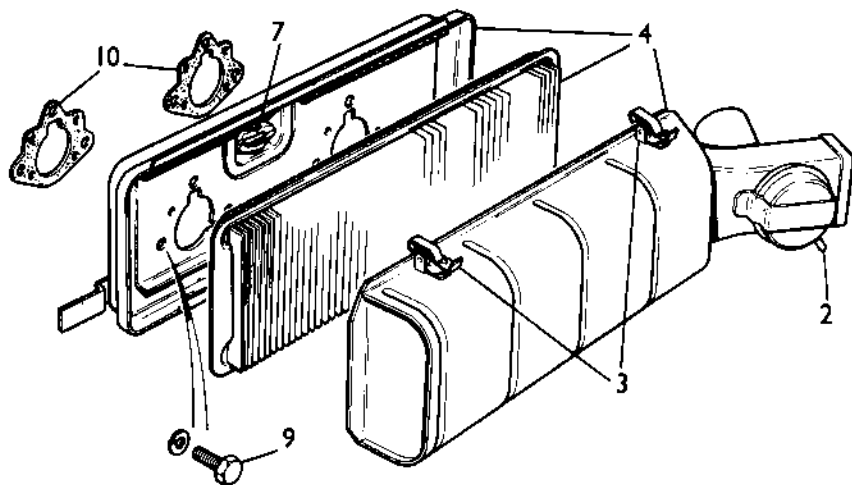

A19-51

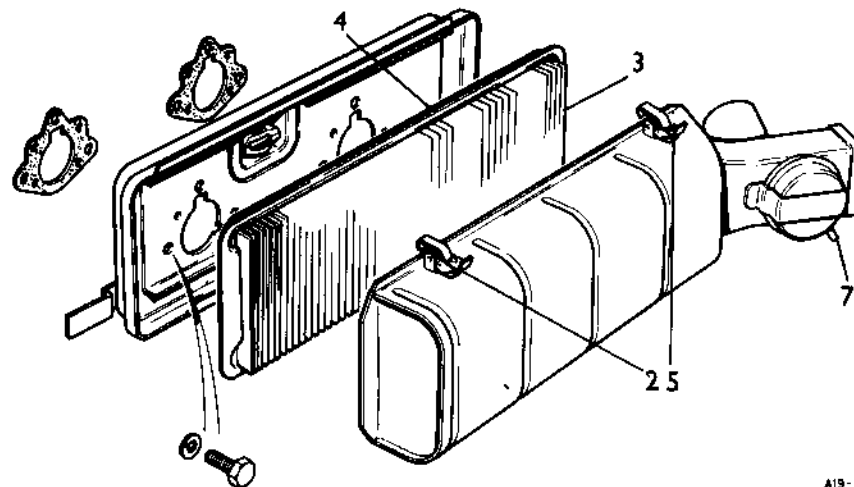

A19-51

## CARBURETTERS

### Tune and adjust

19.15.02

Special tools: Non dispersive infra-red exhaust gas analyser and mixture adjusting tool S353.

**CAUTION:** To ensure compliance with exhaust emission legislative requirements the following items must not be changed or modified in any way:

- The fuel jet assembly.
- The piston assembly.
- The depression cover.

The following items must not be adjusted in service but should be replaced completely by factory-set units:

- The temperature compensator.
- The piston assembly return spring.
- The starter assembly.

**NOTE:** During the course of the following instructions do not allow the engine to idle for longer than three minutes without a 'clear-out' burst of one minute duration at 2000 r.p.m.

- 1 Remove the fresh air duct – 80.15.31.
- 2 Run the engine until normal operating temperature is reached.
- 3 Remove the air cleaner. 19.10.01.

### Adjusting idle speed and air flow for balance

- 4 Ensure that the fast idle screw is clear of the fast idle cam.
- 5 Using an air flow meter check that the air flow through both carburetters is the same. If not, adjust as follows:
- 6 Hold the roller into the corner of the progression lever. – (Canadian Specification only).
- 7 Adjust the spring loaded screws equally until the adjusting bar is in the centre of both forks.
- 8 Unscrew the throttle adjusting screws on both carburetters to permit the throttles to close completely.
- 9 Rotate the throttle adjusting screws so that they just touch the throttle levers and give a further half-turn to provide a datum setting.

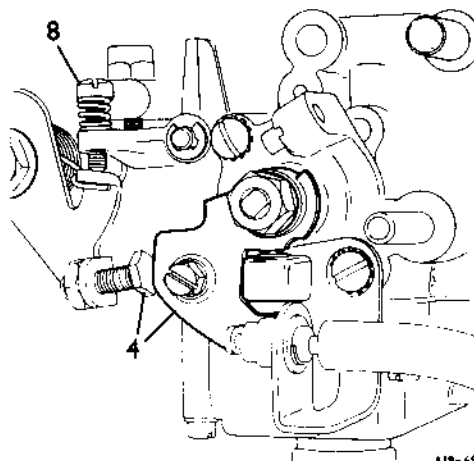

A19-49

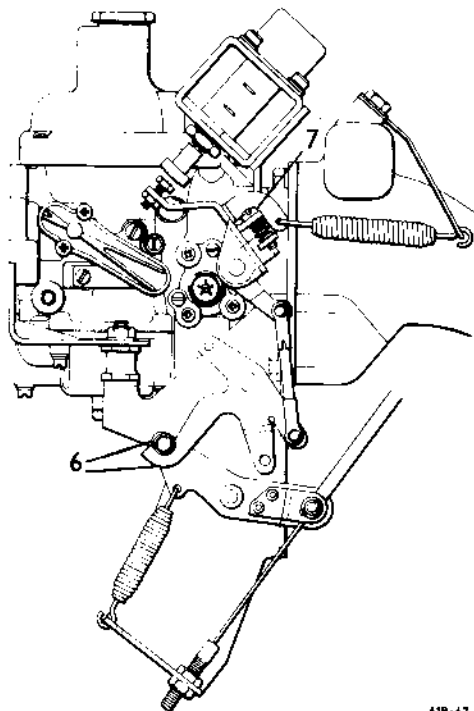

A19-47

- 10 Continue rotating the screws by equal amounts while holding an air flow meter to each carburettor intake in turn, until a balanced air flow is achieved at an engine speed of 800 r.p.m.
- 11 Hold the roller into the corner of the progression lever. – (Canadian Specification only).
- 12 Adjust the spring loaded screws to give a gap of 0.010 in. (0.25 mm) dimension A between the forks and the adjusting bar.
- 13 If necessary turn the throttle adjusting screws on both carburetters an equal amount to maintain the idle speed of 800 r.p.m.
- 14 Increase the engine speed to 1600 r.p.m. and check the balance with the air flow meter. If necessary turn the throttle adjusting screws by equal amounts to achieve a balance.
- 15 Re-check the air flow balance at idle speed.

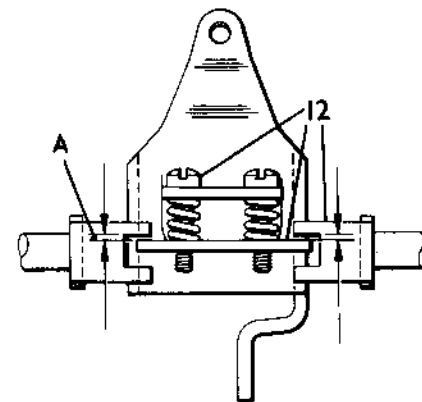

A19-48

### Checking and adjusting CO level at idle – all vehicles

- 16 Disconnect and plug the outlet hose from the air pump.
- 17 Maintain the engine at normal operating temperature, and check that the idle speed is 800 r.p.m.
- 18 Check and if necessary adjust the ignition timing. 86.35.15.
- 19 Re-check the idle speed.
- 20 Insert the gas analyser probe as far as possible into the exhaust pipe.
- 21 Check the CO reading against the emission control decal on the car (under the bonnet lid).
- 22 Adjust the mixture if necessary – see mixture adjustment.
- 23 Check and if necessary adjust the idle speed.
- 24 Withdraw the analyser probe.
- 25 Switch off the ignition.
- 26 Unplug air injection hose and reconnect to the pump.

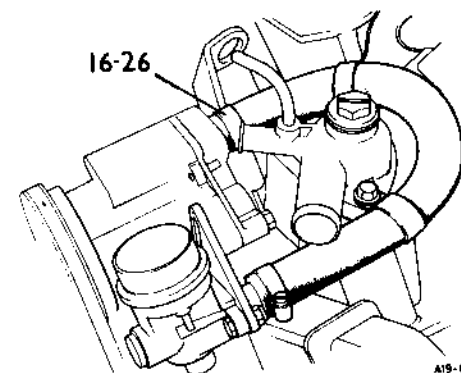

A19-64

**NOTE:** Do not allow the engine to idle for longer than 3 minutes without a 'clear out burst' of 1 minute at 2000 rev/min.

continued

**Mixture adjustment**

**NOTE:** If the CO reading is only slightly outside the permitted limits, adjust the idle trim screw A on both carburetters by equal amounts until the CO reading is to within the limits.

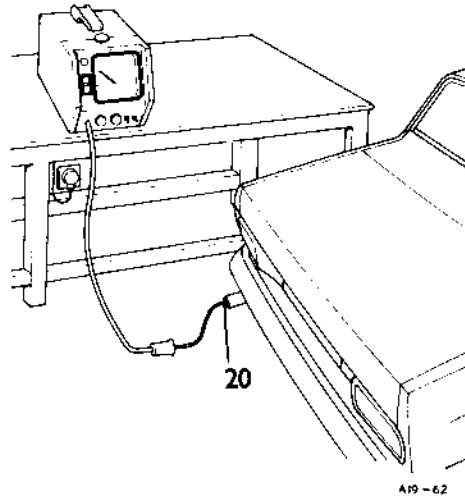
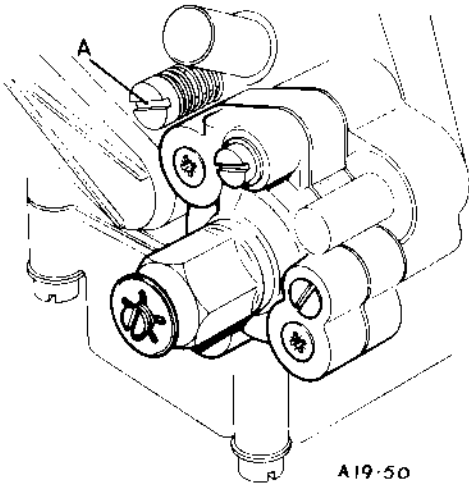

**CAUTION:** The setting **MUST ALWAYS** be checked by means of a non-dispersive infra-red exhaust gas analyser. For significant deviation outside the specified CO limits the mixture should be adjusted as follows:

- 27 Remove the piston damper from both carburetters.
- 28 Carefully insert special tool S353 into the dashpot until the outer tool engages in the air valve and the inner tool engages the hexagon in the needle adjuster plug.

**CAUTION:** The outer tool must be correctly engaged and held in position otherwise damage to the diaphragm may result.

- 29 Holding the outer tool turn the inner tool:
  - a Clockwise to enrich the mixture.
  - b Anti-clockwise to weaken.
- 30 Repeat instruction 28 and 29 on the remaining carburetter ensuring that the adjustment made is by the same amount.
- 31 Top-up the carburetter dampers, ensuring that the special instructions in 'MAINTENANCE' are followed.
- 32 Re-check the CO reading -- instructions 16 to 26 and if necessary repeat instructions 27 to 30 until the CO reading is within the specified limits.

**Checking and adjusting fast idle speed --  
Canadian Specification Vehicles only**

- 33 Maintain the engine at normal running temperature.
- 34 Check that the mixture control cam lever on both carburetters returns to its stop.
- 35 Check and if necessary adjust the mixture control cable so that there is free movement.
- 36 Pull-out the mixture control cable knob on the control cowl approximately  $\frac{1}{4}$  in. until the fast idle cams are correctly engaged with the ball locators.

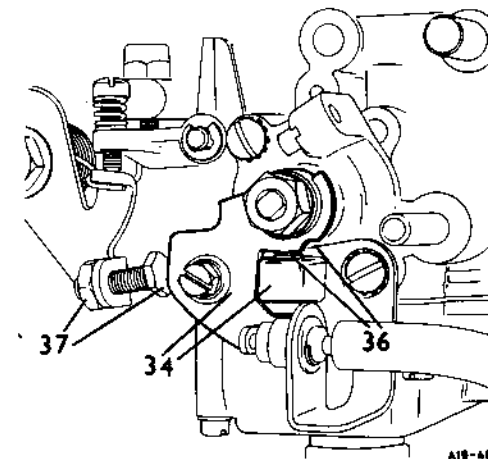
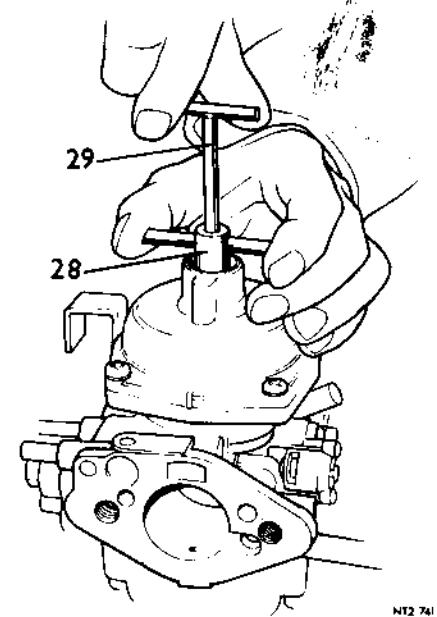



- 37 Slacken the fast idle screw lock-nut on both carburetters, start the engine and rotate the screw head (on both carburetters) against the cam until the engine revolutions reach a steady 1600 r.p.m.
- 38 Use the air flow meter to check that the carburetters are in balance at 1600 r.p.m. if necessary adjust the fast idle screws as required.
- 39 Tighten the fast idle screw lock-nut on both carburetters and push the mixture control knob fully home.

**NOTE:** An engine set to 1600 r.p.m. while hot is equivalent to a fast idle speed of approximately 1300 r.p.m. when cold.

**Checking and adjusting deceleration by-pass valves —**

*California and Canadian Specification Vehicles only*

- 40 Maintain the engine at normal running temperature.
- 41 With the engine idling, disconnect the vacuum pipe from the distributor and place a finger over the end of the pipe.
- 42 If the valves are correctly adjusted the engine idle speed should increase to approximately 1300 r.p.m.
- 43 Should one or both of the valves be 'floating' and therefore out of adjustment the engine revolutions will increase quickly to approximately 2000–2500 r.p.m. Furthermore if the throttle is momentarily opened the resulting increase in r.p.m. will be slow to fall.  
If adjustment is required continue with the following instructions:
- 44 Without removing the circular spring clip, turn the by-pass valve adjusting screw anti-clockwise fully on to its seat on the carburetter NOT being adjusted.

**NOTE:** This procedure prevents the one by-pass valve from working while the valve on the other carburetter is being adjusted. It is not however, necessary to repeat this procedure when adjusting the valve on the second carburetter.

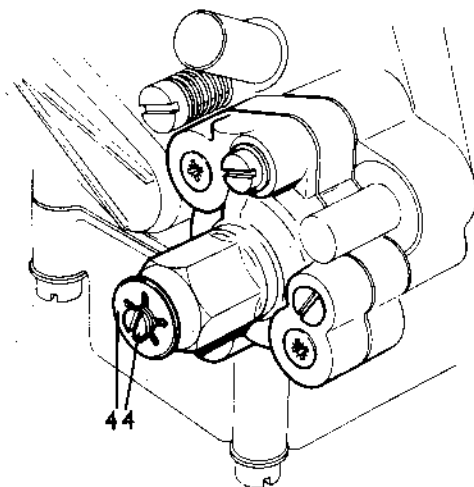
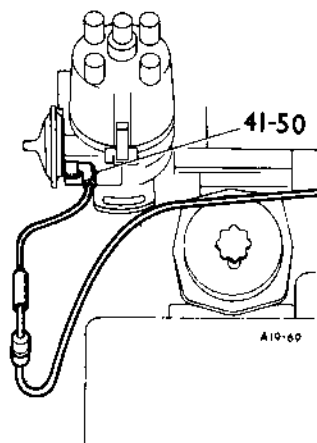

- 45 Remove and plug the vacuum pipe from the distributor.
- 46 With the engine running turn the by-pass valve clock-wise until the engine speed increases abruptly to approximately 2000 to 2500 r.p.m. thereby causing the valve to 'float' on its seat.
- 47 Turn the adjustment screw anti-clockwise until the engine speed falls to approximately 1300 r.p.m.
- 48 Using the throttle, momentarily increase the engine speed and immediately release the throttle. If the valve is correctly adjusted the engine speed should fall to approximately 1300 r.p.m. If not, the valve is still floating and the above adjusting sequence must be repeated.
- 49 When a correct adjustment has been achieved on both carburetters, turn the by-pass valve adjustment screw, on both carburetters, anti-clockwise half a turn to finally seat the valves.
- 50 Unplug the vacuum pipe and connect it to the distributor.

**Checking and adjusting deceleration by-pass Federal Specification Vehicles only — excluding California**

- 51 Maintain the engine at normal running temperature and idling speed.
- 52 Slowly turn the rear carburetter by-pass valve adjusting screw clockwise from the fully loaded position until the engine revolutions begin to increase.
- 53 Turn the by-pass valve adjusting screw anti-clockwise 3 full revolutions.
- 54 Repeat operation No. 1 on the front carburetter by-pass valve adjusting screw.
- 55 Turn the front carburetter adjusting screw anti-clockwise 2 full revolutions.
- 56 Turn the rear carburetter adjusting screw anti-clockwise 1 full revolution.

**CAUTION:** Renewal of the by-pass valves, should it be necessary, must only be done as complete units.

- 57 Refit the air cleaner.
- 58 Refit the fresh air duct. 80.15.31.

## CARBURETTERS - CAR SET

Remove and refit

19.15.11

Which includes:

Carburetter rubber mountings—remove and refit omitting instructions 13, 17 and 25

### Removing

- 1 Disconnect the battery.
- 2 Remove the fresh-air duct. 80.15.31.
- 3 Remove the hot air hose from the air cleaner.
- 4 Remove the air cleaner. 19.10.02.
- 5 Disconnect all the piping from the carburetters.

- 6 Disconnect the fuel feed pipe.
- 7 Disconnect the throttle return spring.
- 8 Disconnect the throttle link.
- 9 Remove the eight nuts, plain and spring washers (four per carburetter) securing the carburetters to the manifold.
- 10 Withdraw the carburetters complete with gaskets.
- 11 Vehicles with air conditioning and automatic transmission only: Remove the electrical leads from the throttle jack.

- 12 Vehicles with air conditioning and automatic transmission only: Remove the throttle jack mounting bracket.
- 13 Remove the six bolts and spring washers (three per mounting) securing the carburetter rubber mountings to the manifold.
- 14 Remove the throttle interconnection linkage and separate the carburetters.

### Refitting

- 15 Fit the carburetter rubber mountings securing with the six (three each side) bolts and spring washers.
- 16 Vehicles with air conditioning and automatic transmission only: Fit the throttle jack mounting bracket.
- 17 Vehicles with air conditioning and automatic transmission only: Connect the electrical leads to the throttle jack.
- 18 Join the carburetters together keeping the interconnection clamps slack.
- 19 Clean the carburetter mating faces and fit new gaskets.
- 20 Fit the carburetters and secure with the eight nuts, plain and spring washers (four per carburetter) tightening the nuts evenly to the correct torque figure.
- 21 Connect the throttle link.
- 22 Connect the fuel feed pipe.
- 23 Connect the mixture control cable.
- 24 Connect the throttle return spring.
- 25 Connect all the piping to the carburetters.
- 26 Tune and adjust the carburetters. 19.15.02.
- 27 Refit the air cleaner. 19.10.02.
- 28 Refit the fresh air duct.

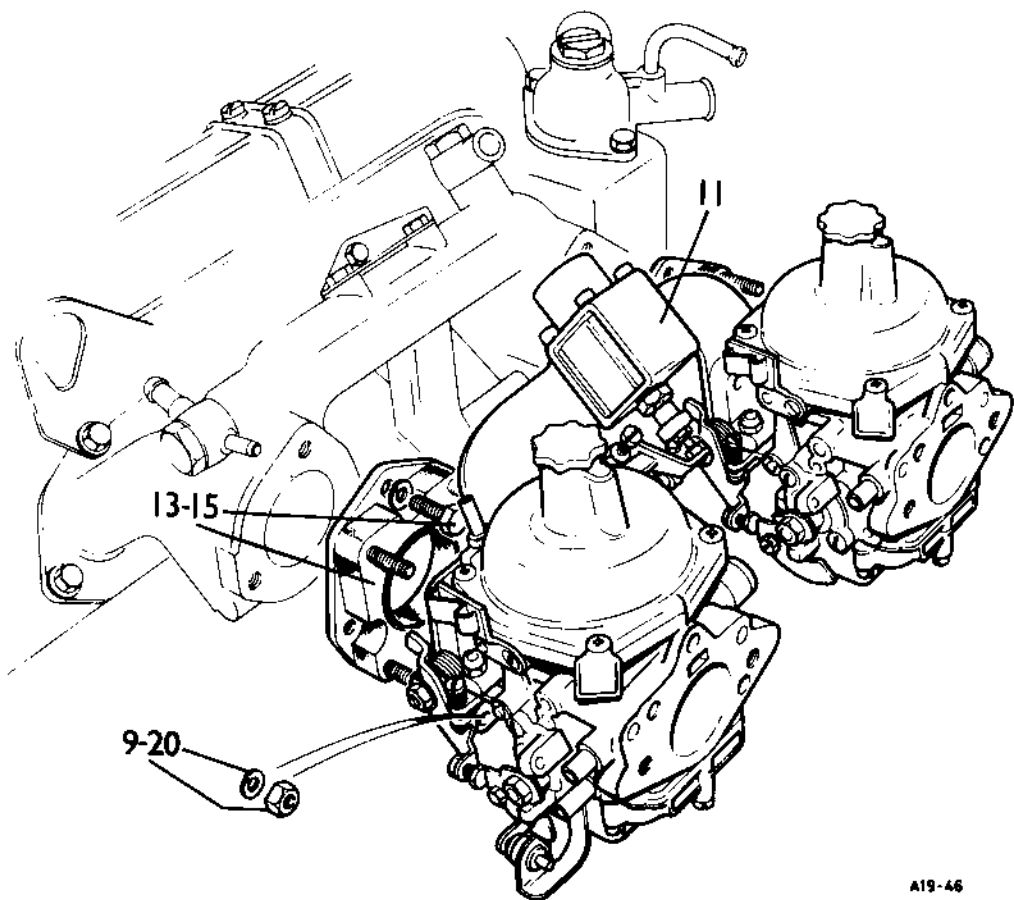

## INLET MANIFOLD COMPLETE WITH CARBURETTERS

Remove and refit 19.15.15

### Removing

- 1 Disconnect the battery.
- 2 Drain the cooling system including the cylinder block. 26.10.01.
- 3 Remove the fresh air duct. 80.15.31.
- 4 Remove the air cleaner. 19.10.02.
- 5 Disconnect the top water hoses from the engine.
- 6 Disconnect all emission control hoses.
- 7 Remove water temperature transmitter lead. 88.25.20. Instruction 3.
- 8 Disconnect petrol main feed pipe to carburetters.
- 9 Disconnect brake servo pipe from manifold connection.
- 10 Disconnect the mixture control cable from the carburetters.

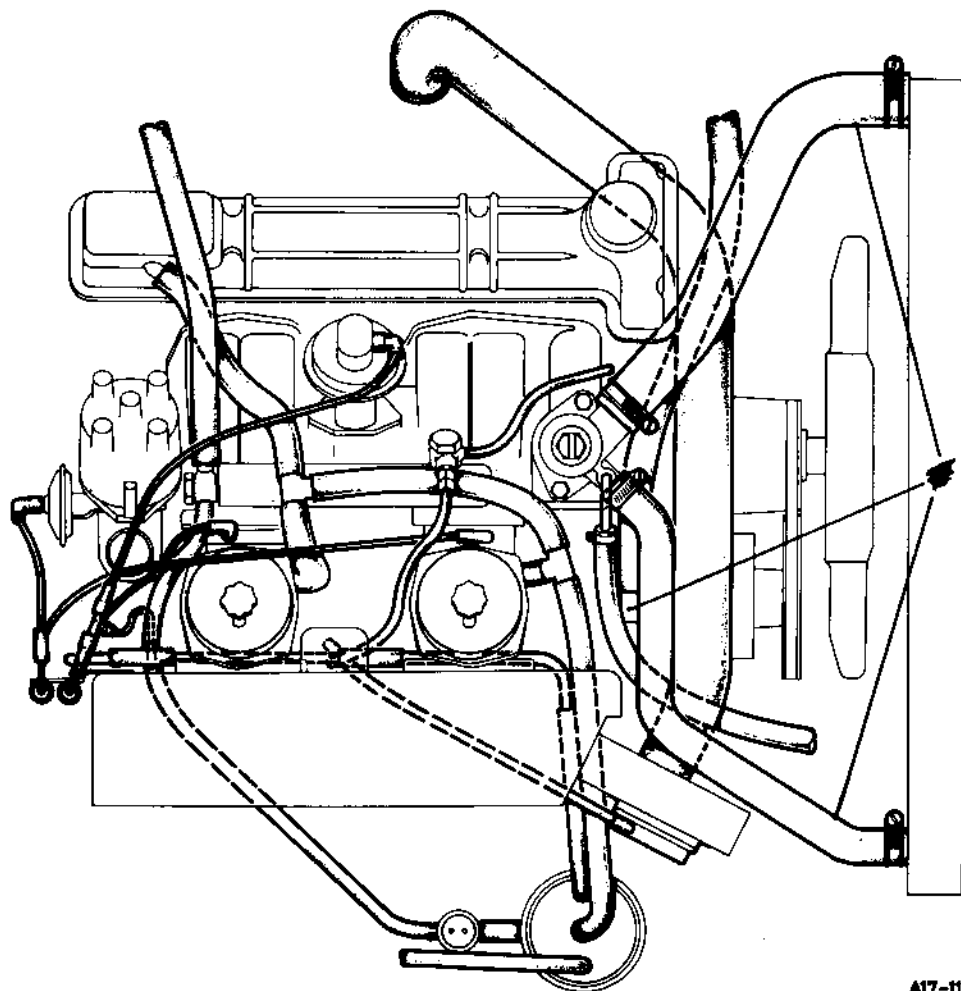

- 11 Disconnect the throttle cable from the carburetters.
- 12 Remove the distributor cap.
- 13 Remove the six manifold attachment bolts.
- 14 Disconnect the heater pipe at the union.
- 15 Lift the manifold complete with carburetters from the cylinder head.
- 16 Remove the 'O' ring.
- 17 Remove the water pump connecting tube, and 'O' rings.
- 18 Remove the gasket.

### Refitting

- 19 Fit a new 'O' ring to the manifold.
- 20 Fit two new 'O' rings to the connecting tube and insert into the pump cover.

**NOTE:** Early engines may be fitted with a moulded type tube, in which case ignore instruction 20 and follow instructions 32 and 33.

- 21 Clean the cylinder head and manifold mating faces and using a new gasket fit the manifold complete with carburetters ensuring that the connecting tube is properly located. Fit the manifold retaining bolts but leave slack.
- 22 Connect the heater pipe to the union but leave the nut slack.
- 23 Tighten the manifold attachment bolts evenly to the correct torque figure and finally tighten the heater union nut.
- 24 Fit the distributor cap.
- 25 Fit the petrol feed pipe to the carburetters.
- 26 Connect the throttle cable and adjust.
- 27 Connect the mixture control cable.
- 28 Connect the lead to the water temperature sensor.
- 29 Reconnect the emission and evaporative control pipe work.
- 30 Fit the air cleaner. 19.10.02.
- 31 Fit the brake servo pipe to the manifold connection.

*continued*

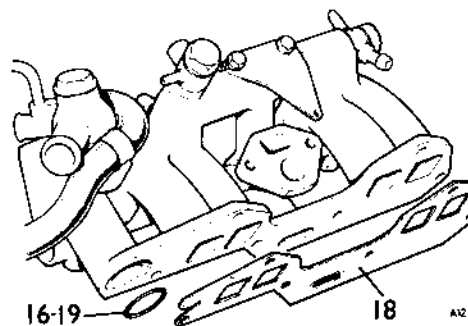
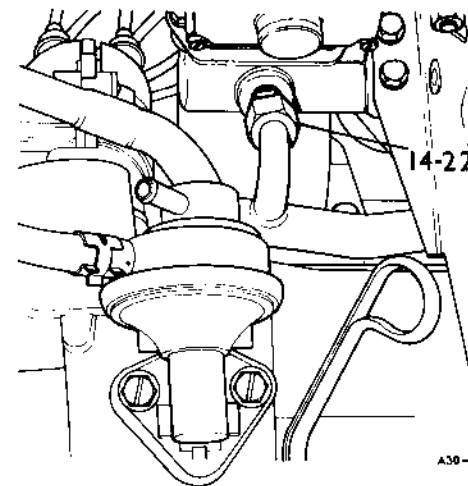

NOTE: Instructions 32 and 33 should only be followed if a moulded type connecting tube is fitted.

- 32 Remove the thermostat housing and thermostat and push the connecting tube fully home.
- 33 Refit the thermostat and housing using a new gasket.
- 34 Reconnect the top water hoses.
- 35 Refit the fresh air duct. 80.15.31.
- 36 Refill the cooling system. 26.10.01.
- 37 Reconnect the battery.
- 38 Run the engine and check for coolant leaks.

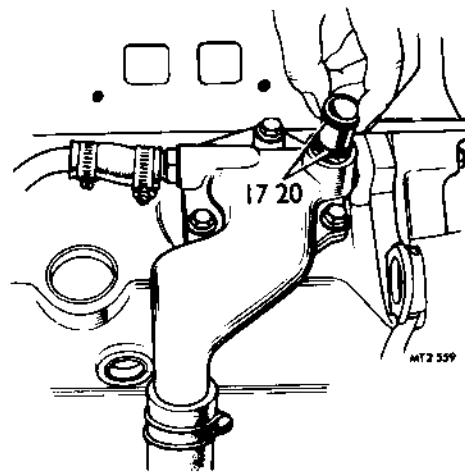

## CARBURETTER RUBBER MOUNTINGS

Remove and refit 19.15.19

This operation is included in Operation 19.15.11

## FLOAT CHAMBER NEEDLE VALVE

Remove and refit 19.15.24

### Removing

- 1 Remove the carburetters. 19.15.11. or
- 2 Remove the six screws securing the float chamber to the body.
- 3 Remove the float chamber.
- 4 Remove the gasket.
- 5 Remove the float assembly by gently prising the spindle from the locating clips.
- 6 Remove the needle valve and washer.

### Refitting

- 7 Fit the needle valve and renew the washer.
- 8 Fit the float assembly.
- 9 Check and if necessary, adjust the height of both floats. Instruction 5. 19.15.32.
- 10 Renew the gasket and refit the float chamber.
- 11 Refit the carburetters.

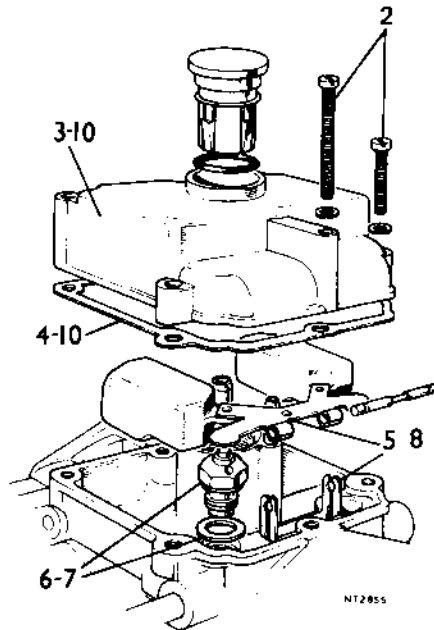

## FLOAT CHAMBER LEVELS

Check and adjust 19.15.32

### Check

- 1 Remove the carburetters. 19.15.11.
- 2 Remove the six screws securing the float chamber to the body.
- 3 Remove the float chamber.
- 4 Remove the gasket.
- 5 With the carburettor in the inverted position check the distance between the gasket face on the carburettor body to the highest point of each float A.

NOTE: The height of both floats must be the same i.e. 0.625 to 0.627 in. (16 to 17 mm).

### Adjust

- 6 Bend the tab that contacts the needle valve but ensure that it sits at right angles to the valve to prevent the possibility of sticking.
- 7 Fit a new gasket and reverse instructions 1 to 3.

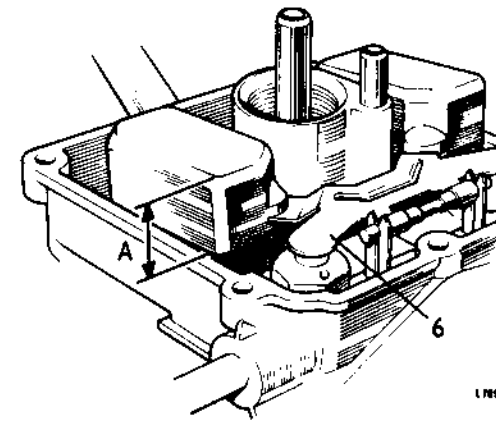

## DIAPHRAGM

Remove and refit 19.15.35

### Removing

- 1 Remove the four screws securing the top cover to the carburettor body.
- 2 Lift off the top cover.
- 3 Remove the diaphragm spring.
- 4 Remove the diaphragm retaining plate.
- 5 Remove the diaphragm.

### Refitting

- 6 Fit the diaphragm, locating the inner tag in the air valve recess.
- 7 Fit the retaining plate and ensure the correct diaphragm seating and tighten the screws.
- 8 Locate the diaphragm outer tag in the recess in the carburettor body.
- 9 Fit the top cover and evenly tighten the screws.
- 10 Check and if necessary top up damper - see special instructions in 'MAINTENANCE'.

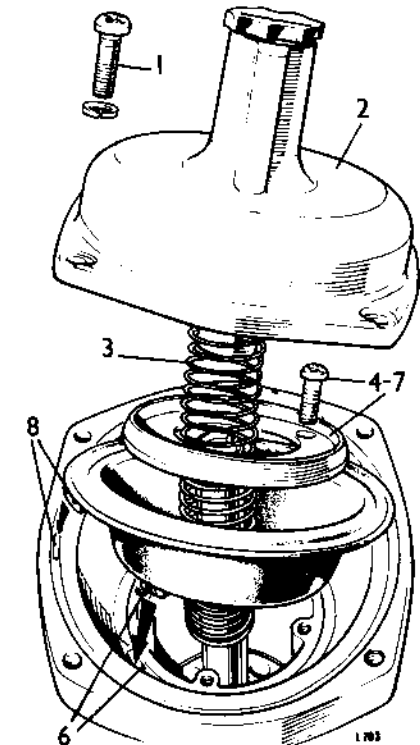

## AUTOMATIC CHOKE (Fully Automatic Starter Device)

Remove and refit 19.15.38

**CAUTION:** The automatic choke must be renewed as a complete unit.

### Removing

- 1 Remove the air cleaner. 19.10.01.
- 2 Slacken the clip securing the auto-choke fuel mixture outlet pipe hose, to the inlet manifold.
- 3 Disconnect the lead from the auto-choke heater.
- 4 Remove the carburetters. 19.15.11.

**NOTE:** The automatic choke is fitted to the front carburetter only.

- 5 Remove the 3 setscrews securing the auto-choke to the carburetter.
- 6 Remove the gasket and auto-choke assembly.

### Refitting

- 7 Reverse instructions 1 to 6.

## STARTER ASSEMBLY – Canadian Specification Vehicles

Remove and refit 19.15.52

**CAUTION:** This component must only be renewed as a complete unit.

### Removing

- 1 Remove the fresh air duct. 80.15.31.
- 2 Remove the air cleaner. 19.15.01.
- 3 Disconnect the mixture control cable (depending upon whether it is the front or rear carburetter).
- 4 Remove the two screws securing the starter assembly to the carburetter body.
- 5 Remove the exhaust gas recirculation control valve (rear carburetter only).
- 6 Withdraw the starter assembly.

### Refitting

- 7 Clean the carburetter and starter mating faces.
- 8 Reverse instructions 1 to 6.

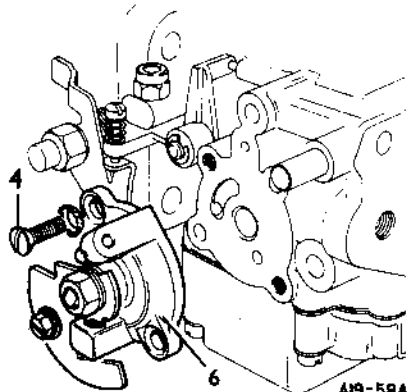

A19-58A

## TEMPERATURE COMPENSATOR

Remove and refit 19.15.59

**CAUTION:** This component must only be renewed as a complete new unit.

### Removing

- 1 Remove the air cleaner assembly. 19.10.01.
- 2 Remove the two screws and shake proof washers securing the temperature compensator to the carburetter.
- 3 Withdraw the compensator complete.
- 4 Remove and discard the outer rubber washer.
- 5 Remove the inner rubber washer from the carburetter body and discard.

### Refitting

- 6 Clean the carburetter and temperature compensator mating faces.
- 7 Insert a new inner rubber washer into the bore in the carburetter body.
- 8 Fit a new outer rubber washer.
- 9 Fit the compensator to the carburetter and secure with the two screws and shakeproof washers.
- 10 Refit the air cleaner.

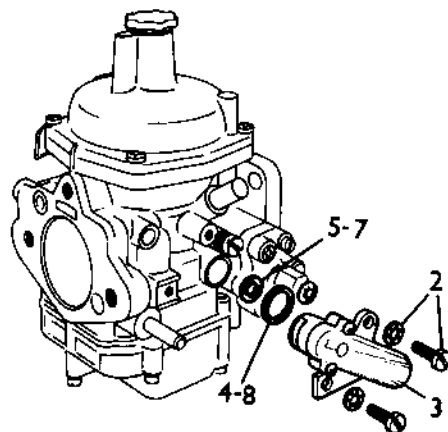

A19-65

## DECELERATION AND BY-PASS VALVE

Remove and refit 19.15.64

**CAUTION:** This component must only be renewed as a complete unit.

### Removing

- 1 Remove the carburetters. 19.15.11.
- 2 Remove the two cheese headed screws and the single countersunk slotted screw (not cross slotted) securing the by-pass valve assembly to the carburetter.
- 3 Withdraw the valve assembly complete.
- 4 Remove the gasket.

### Refitting

- 5 Clean the carburetter and valve assembly mating faces.
- 6 Using a new gasket fit the assembly to the carburetter with the three screws and washers.
- 7 Refit the carburetters to the engine – less the air cleaner and fresh air duct.
- 8 Check and if necessary adjust the deceleration and by-pass valves – 19.15.02 instructions 40 to 52.

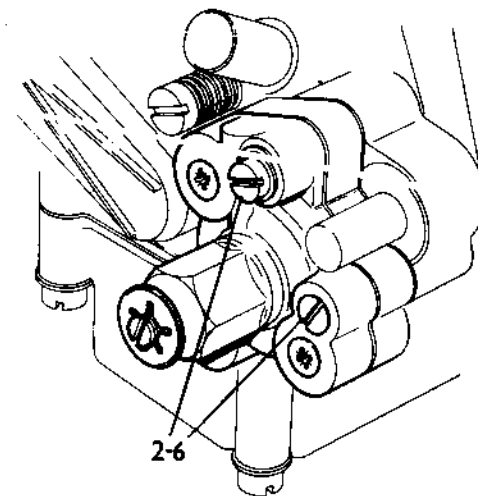

A19-50

**THROTTLE PEDAL ASSEMBLY**

Remove and refit

19.20.01

**Removing**

- 1 Disconnect the battery.
- 2 Working from inside the car remove the spring clip securing the throttle cable.
- 3 Remove the cable from the pedal.
- 4 Open the bonnet and remove the two bolts securing the pedal assembly to the bulkhead.
- 5 Remove the pedal assembly from the car.
- 6 Strip the pedal assembly, and discard worn parts.

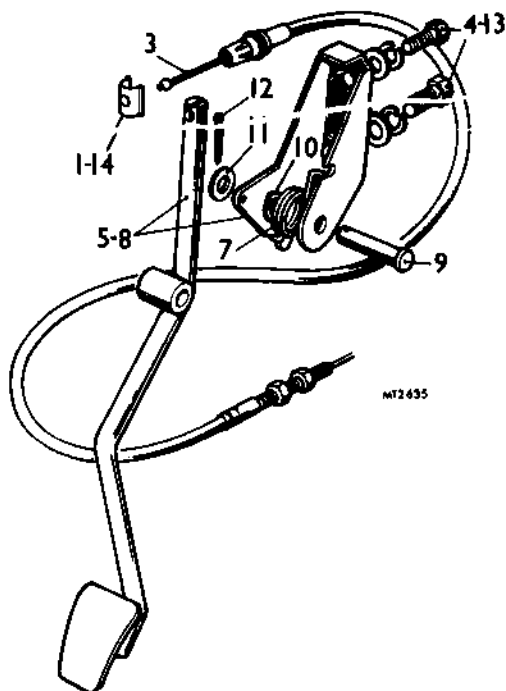
**Refitting**

- 7 Locate the spring in the bracket.
- 8 Fit the pedal to the bracket.
- 9 Insert the clevis pin.
- 10 Fit the anti-rattle washer.
- 11 Fit the washers (plain).
- 12 Secure the assembly with a new split pin.
- 13 Fit the pedal to the bulkhead and secure with the two bolts.
- 14 Fit the cable to the pedal and retain with the spring clip.
- 15 Re-connect the battery.

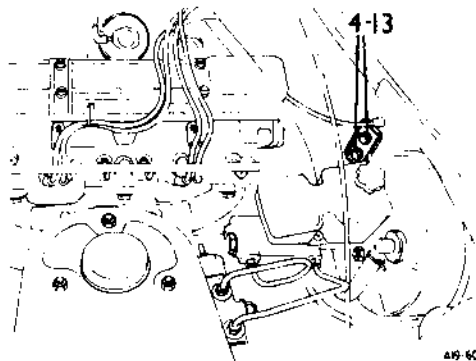
**PETROL PIPE — MAIN LINE — TANK END SECTION**

Remove and refit

19.40.02

**Removing**

- 1 Drive the car on to a ramp and raise.
- 2 Drain the petrol tank.
- 3 Pull off the rubber connection between the tank and main line pipe.
- 4 Release the tank-end section from the engine-end section at the union (right-hand rear wing).
- 5 Release the pipe from the retaining clips and remove from the car.

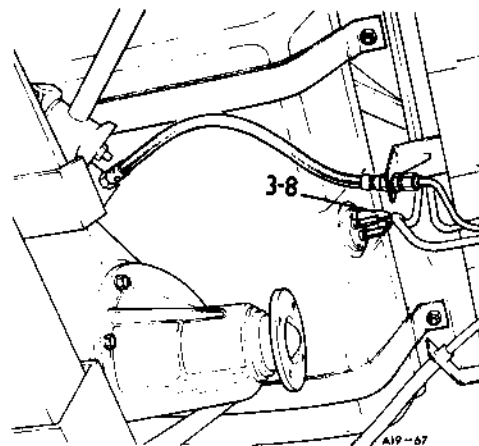
**Refitting**

- 6 Clip the pipe into position.
- 7 Connect the pipe to the engine-end section at the union.
- 8 Connect the pipe to the tank with the rubber connector.
- 9 Lower the ramp and refill the tank.

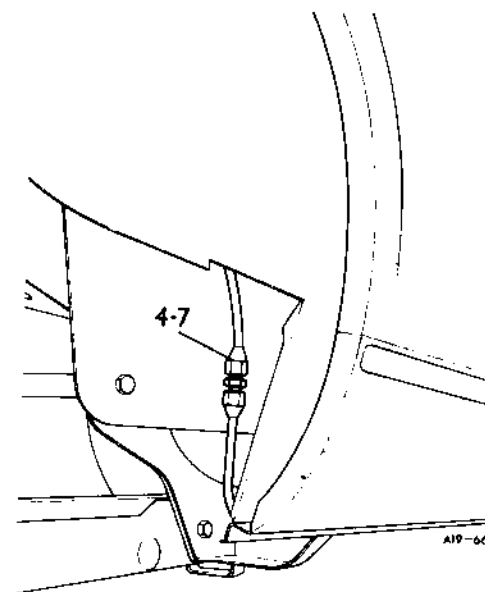

## PETROL PIPE – MAIN LINE – ENGINE END SECTION

– Remove and refit 19.40.04

### Removing

- 1 Drive the car onto a ramp.
- 2 Raise the ramp and drain the petrol tank.
- 3 Disconnect the engine-end section from the petrol tank-end section at the union (right-hand wing).
- 4 Pull off the rubber hose connecting the engine-end section to the fuel pump.
- 5 Remove the pipe from the retaining clips.

### Refitting

- 6 Reverse instructions 3 to 5.
- 7 Start the engine and check for leaks.
- 8 Stop the engine and lower the ramp.

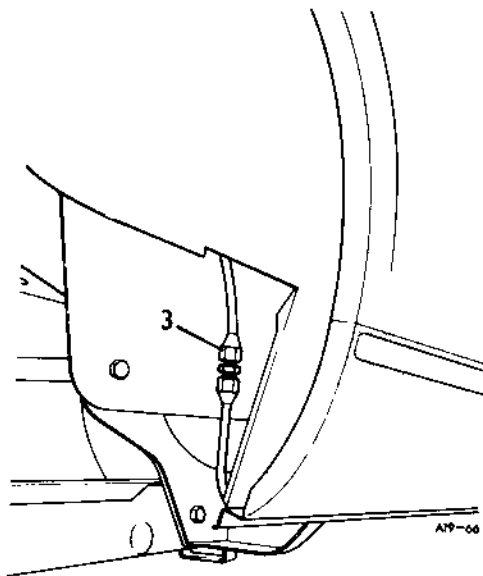

## HOSE – FILLER TO TANK

– Remove and refit 19.40.19

### Removing

- 1 Open the boot and remove the access panel.
- 2 Remove the filler cap assembly. 19.55.08.
- 3 Remove the hoses from the vapour separator.
- 4 Remove the vapour separator by pulling it laterally from its retaining clip.
- 5 Release the hose clip securing the filler hose to the fuel tank, visible through the access aperture.
- 6 Pull off the filler hose.

### Refitting

- 7 Fit the filler hose to the tank and secure with the hose clip.
- 8 Fit the vapour separator by pushing it laterally into its retaining clip.
- 9 Fit the tank breather hose to the vapour separator L.H. connection.
- 10 Fit the hose to the adsorption canister pipe run to the R.H. connection on the vapour separator.
- 11 Fit the fuel filler cap assembly – instructions 7 to 10. 19.55.08.
- 12 Fit the access panel.

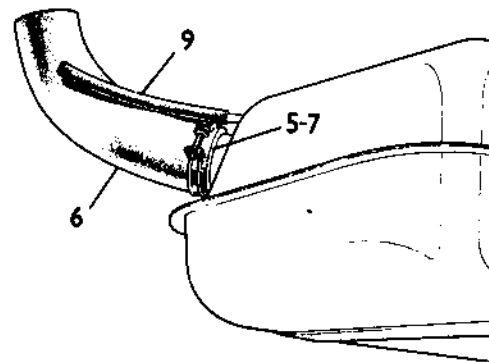
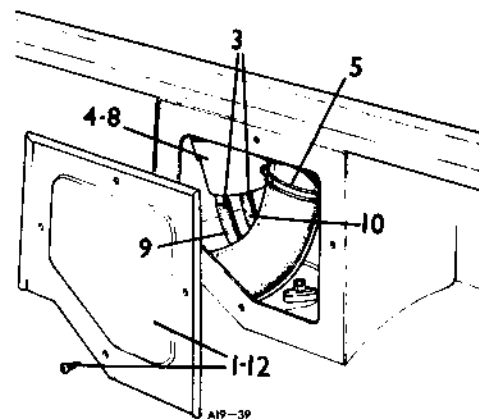

**FUEL PUMP**

Clean filter 19.45.05

- 1 Remove the fresh air duct. 80.15.31.
- 2 Remove pump cover retaining screw.
- 3 Lift off the cover.
- 4 Lift out the filter.
- 5 Clean sediment from the filter and cover.
- 6 Refit the cover renewing, if necessary the rubber seal.
- 7 Secure the cover with the retaining screw and fit, if necessary, a new fibre washer under the screw head.
- 8 Refit the fresh air duct.

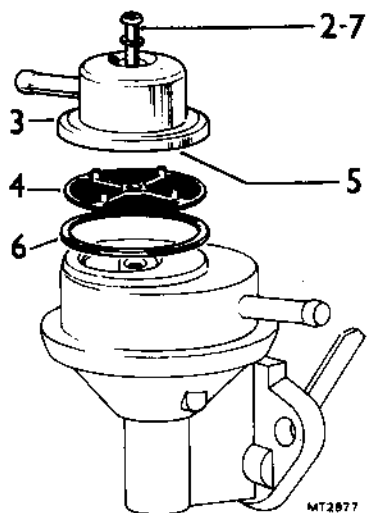
**FUEL PUMP**

Remove and refit 19.45.08

**Removing**

- 1 Remove the fresh air duct. 80.15.31.
- 2 Remove the inlet hose to the pump.
- 3 Remove the outlet hose from the pump.
- 4 Remove the two fuel pump retaining bolts and plain washers.
- 5 Withdraw the pump complete with gasket.

**Refitting**

- 6 Reverse instructions 1 to 5 ensuring that when fitting, the pump actuating lever rides on top of the jackshaft cam.

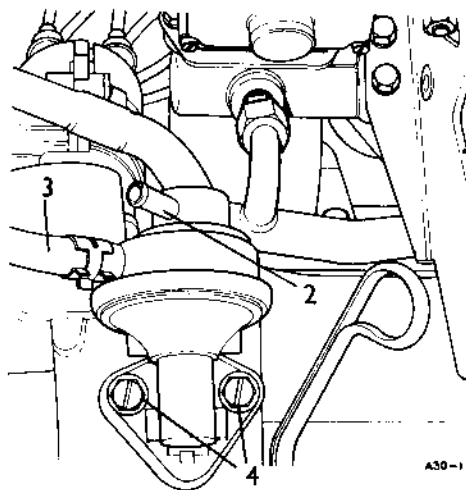
**FUEL TANK**

Remove and refit 19.55.01

**Removing**

- 1 Drive the car onto a ramp and disconnect the battery.
- 2 Remove the fuel filler cap assembly. 19.55.08.
- 3 Disconnect the pipe from the tank to the vapour separator.
- 4 Raise the ramp and drain the fuel tank.
- 5 Support the body with jacks both sides of the car forward of the trailing arm attachment points.
- 6 Disconnect the dampers at their lower attachment to the axle.
- 7 Disconnect the tank unit electrical leads.
- 8 Pull off the rubber connection to the main fuel line.
- 9 Disconnect the R.H. radius rod from the body bracket.
- 10 Remove the L.H. radius rod from the car.
- 11 Jack up the body sufficiently to remove both road springs.

**CAUTION:** Care must be taken to ensure that whilst jacking up the body the brake hydraulic system jump hose is not stretched—shown arrowed.

- 12 Remove the L.H. rear road wheel and allow the axle to drop having regard for the above cautionary note.
- 13 Support the axle with a jack to relieve any tension in the hydraulic jump hose.
- 14 Remove the tail pipe and silencer assembly. 30.10.22.
- 15 Remove the L.H. bump stop.
- 16 Remove the four nuts and tank retaining straps.
- 17 Withdraw the tank from the L.H. side of the car.
- 18 Remove the filler hose.
- 19 Remove the breather hose.
- 20 Remove the tank unit—88.25.32 instructions 6 to 8.

**NOTE:** Instructions 18 to 20 are only necessary if the tank is to be renewed.

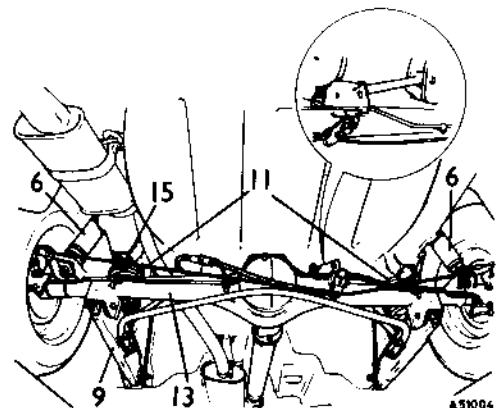
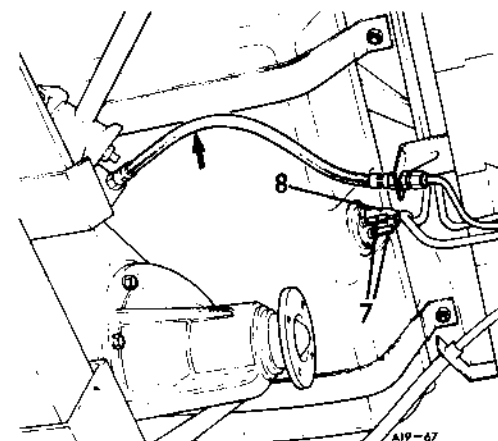
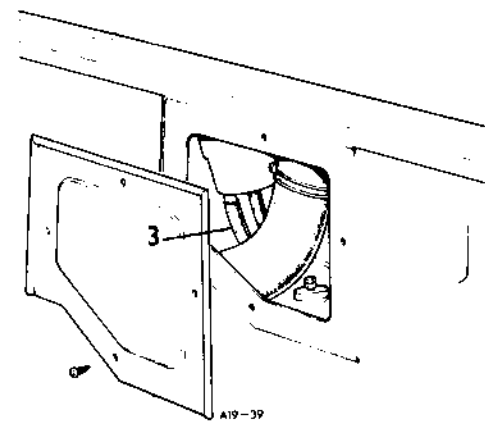



## Refitting

**NOTE:** If the tank is not being renewed ignore instructions 19 to 22. However, renew all hoses if any deterioration exists.

- 21 Using adhesive fit new cushion strips to the tank noting that thicker strips are fitted to the top of the tank.
- 22 Fit the filler hose.
- 23 Fit the breather hose.
- 24 Fit the tank unit – reversing instructions 6 to 8. 88.25.32.
- 25 Manoeuvre the tank into position from the L.H. side of the car.
- 26 Fit the supporting straps noting that the elongated holes in the straps are fitted to the rear studs in the body.
- 27 Fit and tighten the four retaining nuts.
- 28 Fit the L.H. radius rod to the axle – including the handbrake cable bracket – leaving the body-end free for the time being.
- 29 Fit the springs and jack-up the axle both sides and connect the dampers to their axle locations.
- 30 Fit the L.H. bump stop.
- 31 Fit the L.H. and R.H. radius rods to their body locations.
- 32 Fit the tail pipe and silencer assembly. 30.10.22.
- 33 Fit the L.H. rear road wheel.
- 34 Lower and remove the body and axle jacks.
- 35 Connect the fuel tank to the main line pipe with the rubber connector.
- 36 Fit the electrical leads to the tank unit – instruction 10. 88.25.32.
- 37 Fit the breather pipe from the tank to the L.H. connection on the vapour separator.
- 38 Lower the ramp and fit the fuel filler assembly. 19.55.08 instructions 7 to 10.
- 39 Fit the access panel.
- 40 Refill the fuel tank, connect the battery, start the engine and check for leaks.

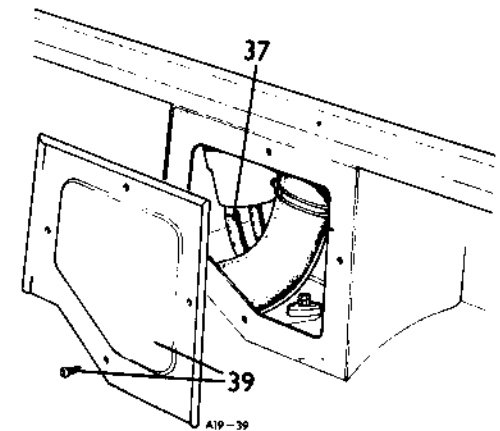
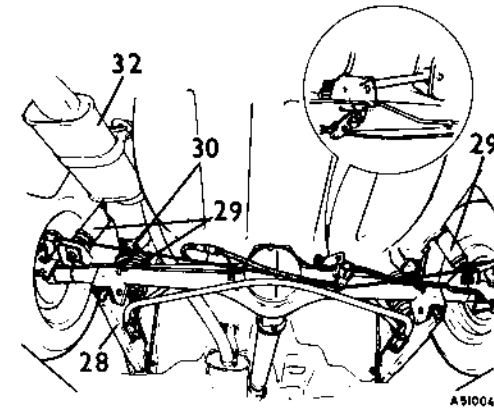
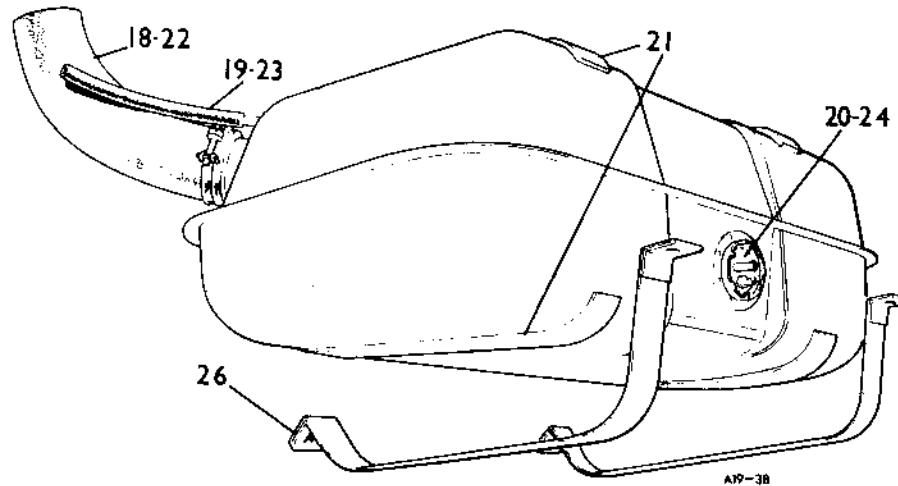
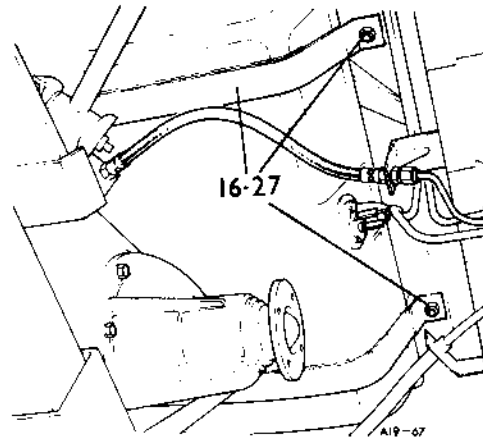

## FUEL FILLER CAP AND FILLER ASSEMBLY

Remove and refit

19.55.08

### Removing

- 1 Turn the fuel filler cap anti-clockwise and withdraw.
- 2 Remove the three screws securing the filler tube assembly to the body.
- 3 Open the boot and remove the access panel - four screws.
- 4 Slacken the top hose clip.
- 5 Withdraw the filler tube.
- 6 Remove the finisher.

### Refitting

- 7 Place the finisher in position.
- 8 Insert the filler tube into the filler hose and secure with the three screws.
- 9 Refit the filler cap.
- 10 Tighten the filler hose top clip.
- 11 Refit the access panel and close the boot.

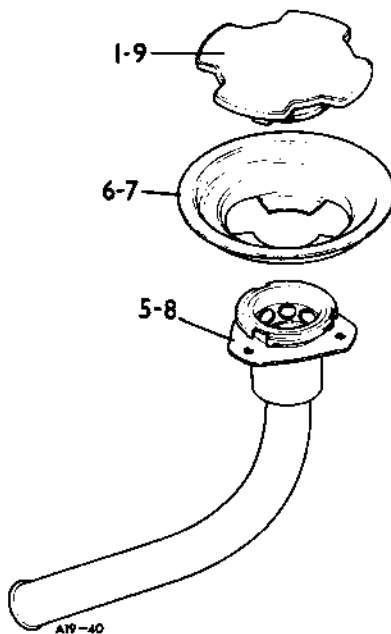
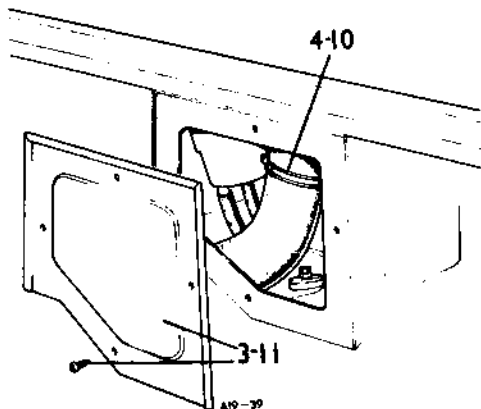
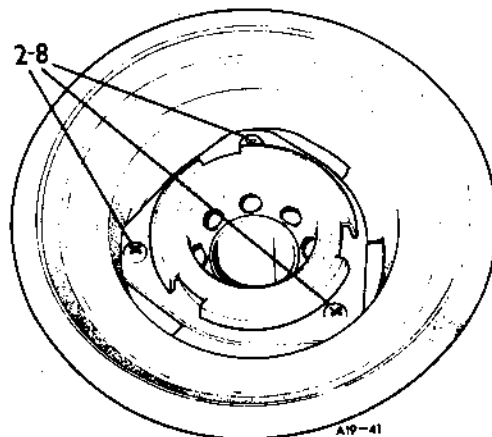

## COOLANT

Drain and refill

26.10.01

### Draining

**WARNING:** This operation must only be carried out when the engine is cold.

- 1 Disconnect the battery.
- 2 Place a suitable container beneath the radiator bottom hose connection.
- 3 Remove the thermostat housing filler plug.
- 4 Disconnect the bottom hose at the radiator and allow the coolant to drain.
- 5 Remove the cylinder block drain plug. 12.25.07.

### Refitting

- 6 Fit and tighten the cylinder block drain plug using a new washer. 12.25.07.
- 7 Connect the bottom hose to the radiator.
- 8 Check that the expansion tank is half-full.
- 9 Set the heater control to 'HOT'.
- 10 Fill the system through the thermostat housing to the bottom of the threads, with the correct mixture of a recommended anti-freeze solution – see 'LUBRICANTS & ANTI-FREEZE SOLUTIONS'.
- 11 Fit the thermostat housing filler plug.
- 12 Reconnect the battery and run the engine for approximately three minutes whilst checking for leaks.
- 13 Stop the engine, remove the thermostat housing filler plug and top-up with coolant as in instruction 10.
- 14 Fit the filler plug using a new washer if necessary.

**NOTE:** Subsequent topping-up of the cooling system should be carried out, when the engine is cool, via the expansion tank which must be maintained at half-full.

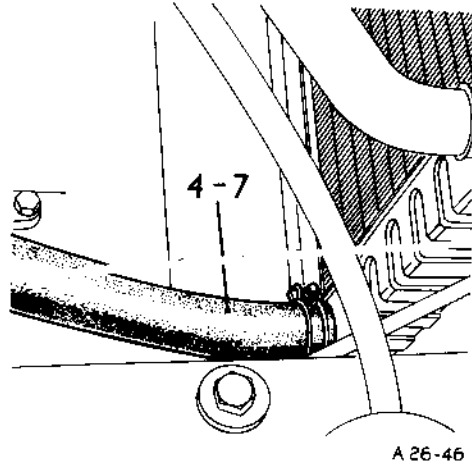
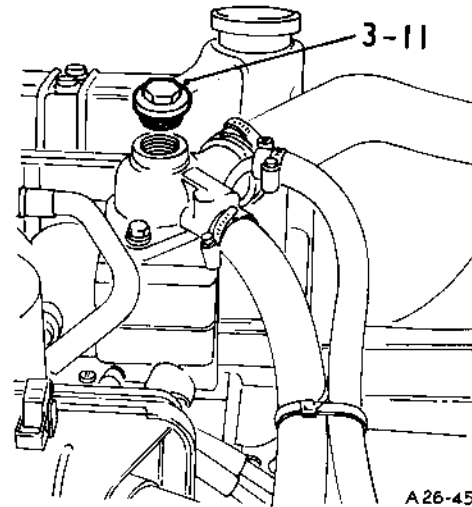

## EXPANSION TANK

Remove and refit

26.15.01

### Removing

**WARNING:** This operation must only be carried out when the engine is cold or cool.

- 1 Disconnect the expansion pipe from the thermostat housing.
- 2 Remove the expansion tank pressure cap and allow the coolant to drain into a suitable clean container.
- 3 Remove the expansion pipe from the expansion tank.
- 4 Slacken the expansion tank retaining clamp nut and bolt.
- 5 Withdraw the expansion tank.
- 6 Remove the overflow pipe from the tank.

### Refitting

- 7 Fit the tank into the clamp and secure.
- 8 Fit the overflow pipe.
- 9 Fit the expansion pipe to the tank and thermostat housing.
- 10 Half-fill the expansion tank with the correct mixture of anti-freeze and water.
- 11 Refit the pressure cap.

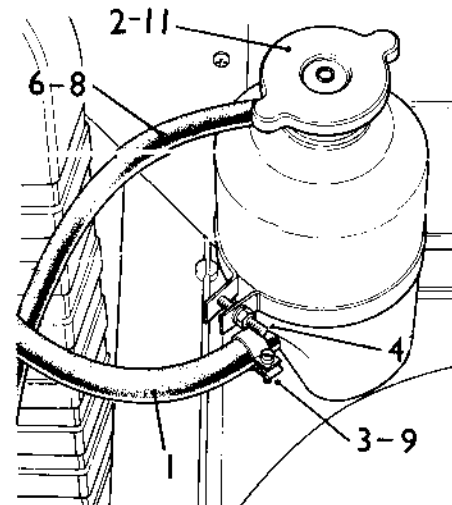

## FAN AND ALTERNATOR DRIVE BELT – UK and Europe

Remove and refit

26.20.07

### Removing

- 1 Disconnect the battery.
- 2 Slacken the alternator adjustment bolts and move the alternator towards the engine.
- 3 Slip the belt from the pulleys and feed it over the fan blades to remove it from the engine.

### Refitting

- 4 Reverse instructions 1 to 3 ensuring that the drive belt is correctly tensioned. 86.10.05.

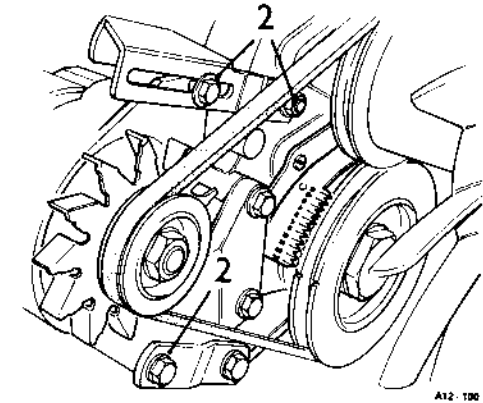

## FAN – ALTERNATOR DRIVE BELT – USA Specification Vehicles

Remove and refit

26.20.07

### Removing

- 1 Disconnect the battery.
- 2 Raise the car and slacken-off the air conditioning compressor belt adjustment bolts—see operation 82.10.02 instructions 1 to 3.
- 3 Remove the fan guard—two bolts.
- 4 Slacken off the four fan blade attachment nuts and bolts to provide a clearance for removing the belt.

*continued*

- 5 Slacken-off the air pump adjustment—see operation 17.25.13. and remove the belt from the pump pulley only.
- 6 Slacken-off the alternator adjustment bolts and remove the drive belt, feeding it over the air pump and compressor belts.

**Refitting**

- 7 Refit the alternator—fan drive belt—reversing instruction 6 and correctly tension the belt. 86.10.05.
- 8 Fit the air pump belt and correctly tension. 17.25.13.
- 9 Fit and adjust the compressor belt, see operation 82.10.01. instructions 7 to 11.
- 10 Tighten the fan blade attachment bolts.
- 11 Refit the fan guard.
- 12 Reconnect the battery.

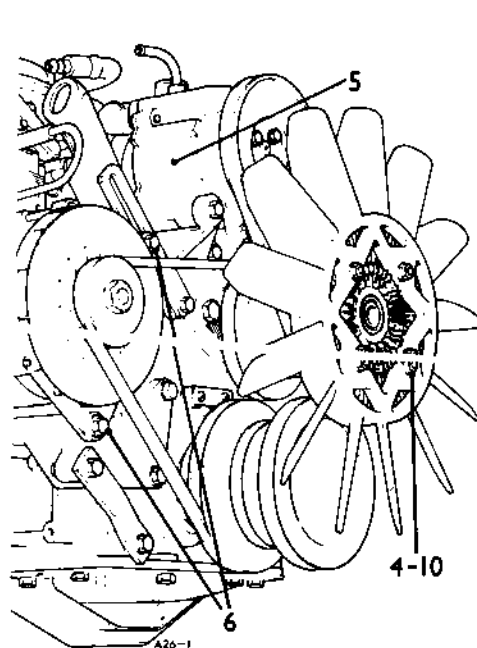
**FAN BLADES**

Remove and refit

26.25.06

**Removing**

- 1 Disconnect the battery.
- 2 Remove the fan blade shield.
- 3 Slacken-off the nuts securing the radiator top support brackets sufficiently to move the radiator forward—away from the engine.
- 4 Remove the four nuts and bolts securing the blades to the viscous coupling.
- 5 Move the radiator forward whilst withdrawing the fan blades vertically.

**Refitting**

- 6 Fit the fan blades to the torquatrol unit and tighten the retaining nuts and bolts evenly.
- 7 Tighten the four radiator support bracket nuts.
- 8 Refit the fan blade shield.
- 9 Reconnect the battery.

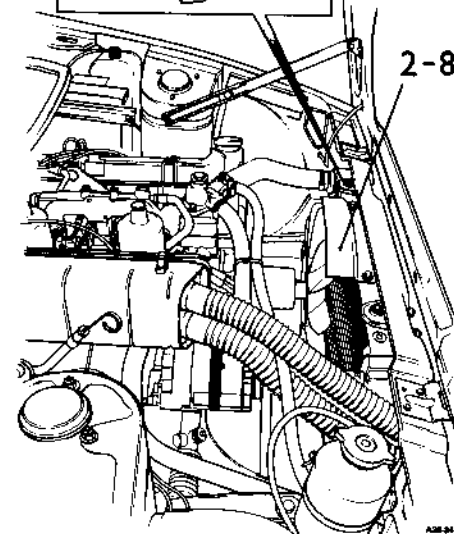
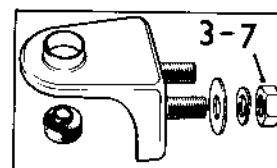
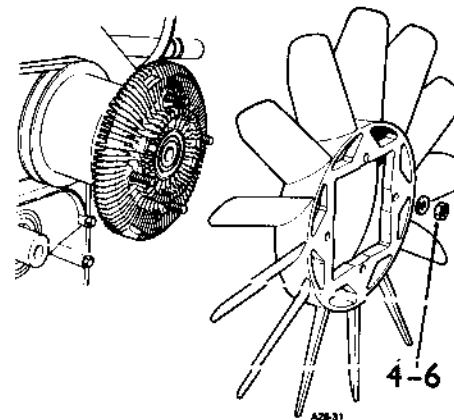
**VISCOUS COUPLING**

Remove and refit

26.25.19

**Removing**

- 1 Remove the fan blades and pulley assembly. 26.25.21.
- 2 Remove the fan blades. 26.25.06.
- 3 Place a support at the back of the torquatrol unit as close to the centre as possible and using a suitable press tool, press the pulley assembly from the viscous coupling.
- 4 Remove the tolerance ring.

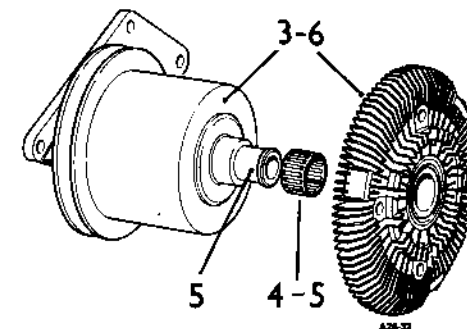
**Refitting**

- 5 Fit a new tolerance ring in position on the pulley bearing shaft.
- 6 Compress the tolerance ring with the fingers whilst locating the viscous coupling on the bearing shaft. Ensure that the coupling is fitted the correct way round—see illustration.
- 7 Press the unit squarely onto the shaft keeping the tolerance ring compressed.
- 8 Refit the fan blades.
- 9 Fit the fan blades and pulley assembly to the engine. 26.25.21.

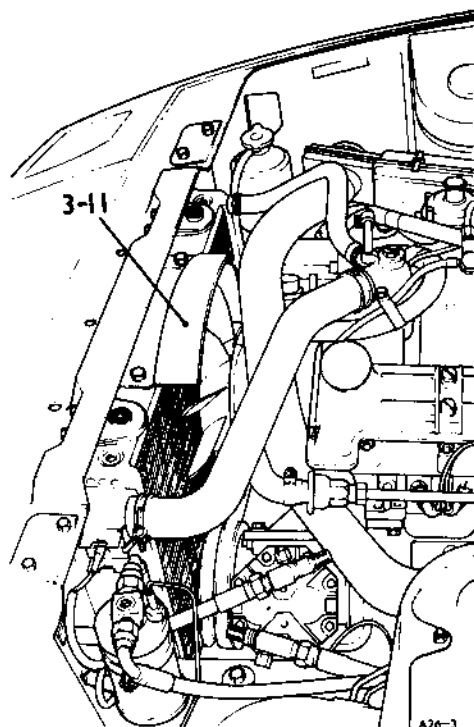

## FAN PULLEY AND BLADE ASSEMBLY – UK and Europe

Remove and refit 26.25.21

### Removing

- 1 Disconnect the battery.
- 2 Slacken the alternator adjustment and slip the belt from the pulleys.
- 3 Remove the four bolts retaining the pulley assembly to the timing cover.
- 4 Withdraw the pulley assembly from the left-hand side of the engine.

### Refitting

- 5 Reverse instructions 1 to 4.

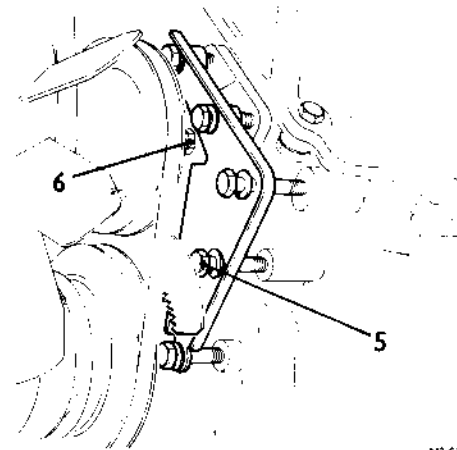
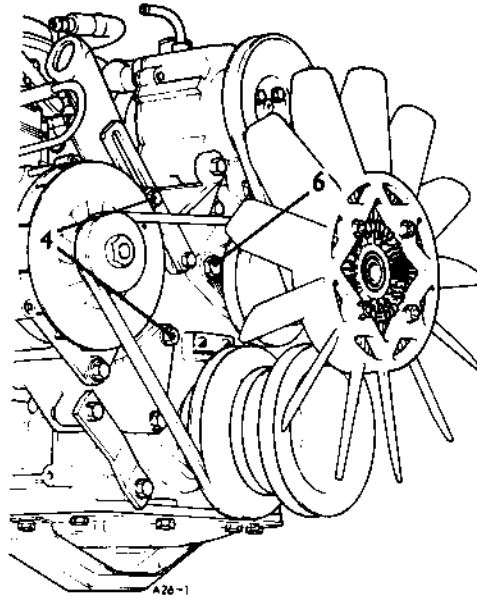
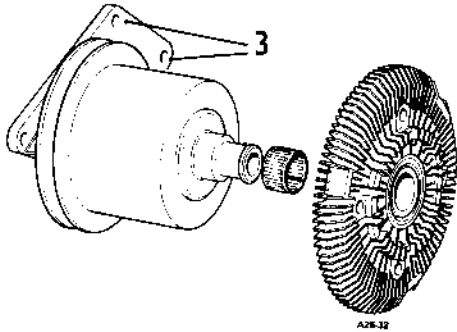

## FAN PULLEY AND BLADE ASSEMBLY – USA Specification

Remove and refit 26.25.21

### Removing

- 1 Disconnect the battery.
- 2 Remove the bonnet, 76.16.01.
- 3 Remove the air pump, 17.25.07.
- 4 Slacken the alternator adjustment and slip the belt from the pulleys.
- 5 Remove the five bolts securing the air compressor steady bracket.
- 6 Remove the remaining two bolts securing the pulley assembly to the timing chain cover i.e. one on L.H.S. and one on R.H.S. of pulley assembly.
- 7 Remove the fan blade guard (two bolts).

- 8 Slacken the four bolts securing the radiator top location brackets sufficiently to enable the radiator to be moved forward.
- 9 Pull the radiator forward—away from the engine—and withdraw the fan pulley assembly complete with fan blades and torquatrol unit.

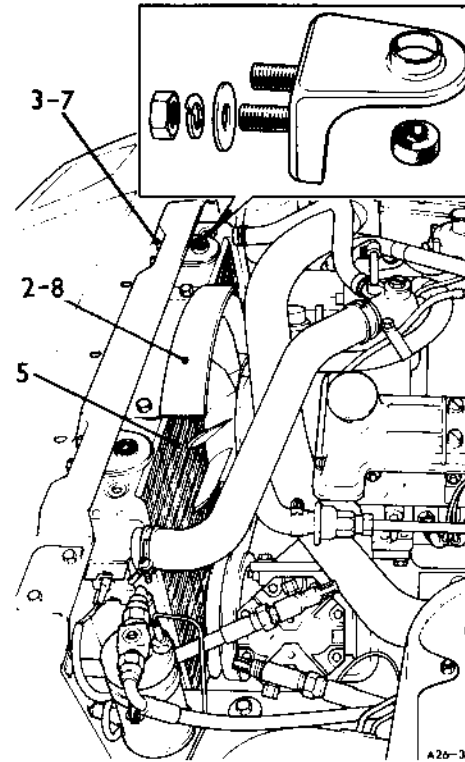

### Refitting

**NOTE:** Before refitting the assembly ensure that the alternator and air pump drive belts are in their correct relative positions.

- 10 Place the drive belt on the fan pulley and offer the assembly to the engine.
- 11 Locate the assembly with the two short bolts, i.e. those not common to securing the compressor bracket and fan pulley assembly.
- 12 Fit the steady bracket and tighten the remaining five bolts.
- 13 Fit the air pump and correctly tension the drive belt.
- 14 Tighten the radiator top location brackets.
- 15 Fit the fan guard.
- 16 Fit the bonnet, 76.16.01.
- 17 Reconnect the battery.

## RADIATOR TOP HOSES

Remove and refit 26.30.01

### Removing

**WARNING:** This operation must only be carried out when the engine is cold or cool.

- 1 Disconnect the battery.
- 2 Partially drain the radiator.
- 3 Disconnect and remove the two top hoses.

### Refitting

- 4 Fit the two hoses and tighten the clips.
- 5 Top-up the cooling system—26.10.01—with the correct mixture of anti-freeze.
- 6 Reconnect the battery.
- 7 Check for leaks after the engine has been run and attained normal operating temperature.

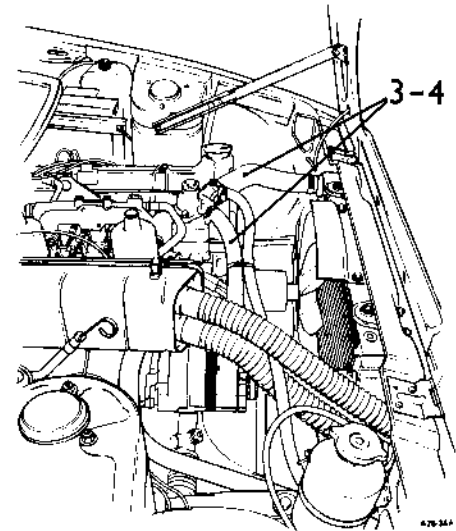

**RADIATOR BOTTOM HOSE**

Remove and refit 26.30.07

**Removing**

**WARNING:** This operation must only be carried out when the engine is cold or cool.

- 1 Disconnect the battery.
- 2 Place a suitable container below the hose connection to the radiator, disconnect the hose from the radiator and allow the coolant to drain.
- 3 Disconnect and remove the hose from the water pump cover connection.

**Refitting**

- 4 Place the hose clips over the hose and fit the hose to the pump and radiator. Tighten the clips.
- 5 Connect the battery.
- 6 Refill the cooling system. 26.10.01.

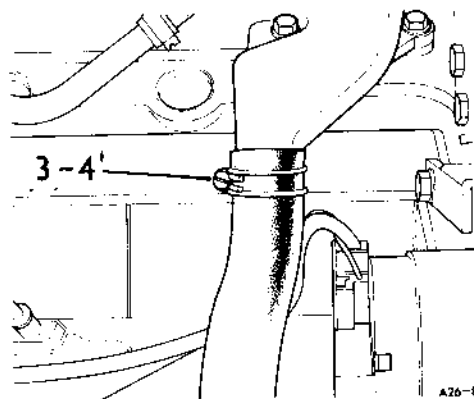
**CONNECTING TUBE**

Remove and refit 26.30.25

See Operation 30.15.02

**RADIATOR**

Remove and refit 26.40.01

**Removing**

- 1 Disconnect the battery.
- 2 Drain the cooling system. 26.10.01.
- 3 Disconnect from the radiator the two top hoses.
- 4 Remove the temperature sensor leads from the L.H. side of the radiator. — Air conditioning specification vehicles.
- 5 Remove the four nuts and washers securing the two radiator attachment brackets.
- 6 Remove the brackets.
- 7 Withdraw the radiator vertically.

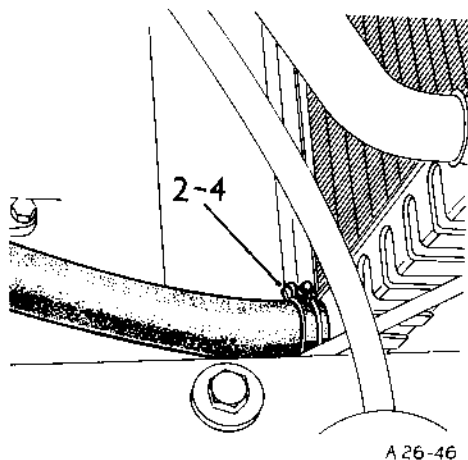

A 26-46

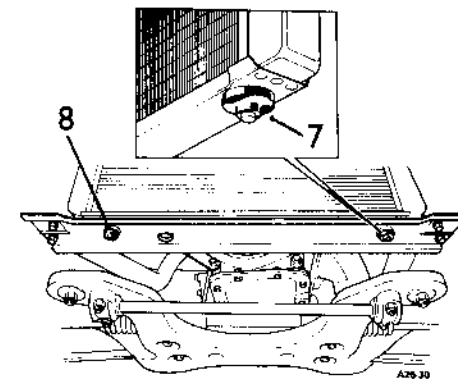

A 26-30

**Refitting**

- 8 Ensure that the four radiator mounting rubbers are in position on the radiator—two top, two bottom.
- 9 Lower the radiator into position ensuring that the bottom mounting rubbers locate properly in the holes in the radiator support crossmember.
- 10 Refit the radiator top support brackets.
- 11 Refit the top hoses.
- 12 Reconnect the bottom hose.
- 13 Refill the cooling system. 26.10.01.
- 14 Reconnect the temperature sensor leads.
- 15 Reconnect the battery.

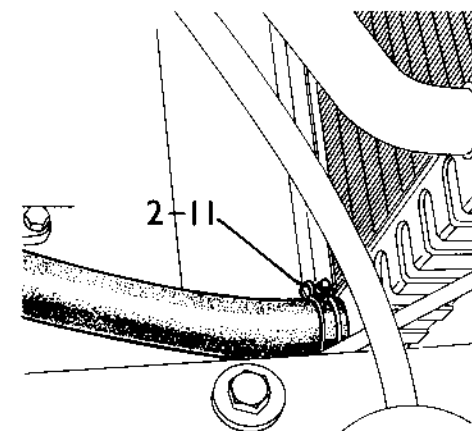

A 26-46

## THERMOSTAT

Remove and refit

26.45.01

### Removing

**WARNING:** This operation must only be carried out when the engine is cold.

- 1 Disconnect the battery.
- 2 Partially drain the cooling system.
- 3 Remove the two bolts securing the thermostat housing dome.
- 4 Lift off the dome and withdraw the thermostat.

### Refitting

- 5 Locate the thermostat in the housing.
- 6 Using a new gasket fit the domed cover and evenly tighten the retaining bolts.
- 7 Reconnect the battery.
- 8 Top-up and check the cooling system.

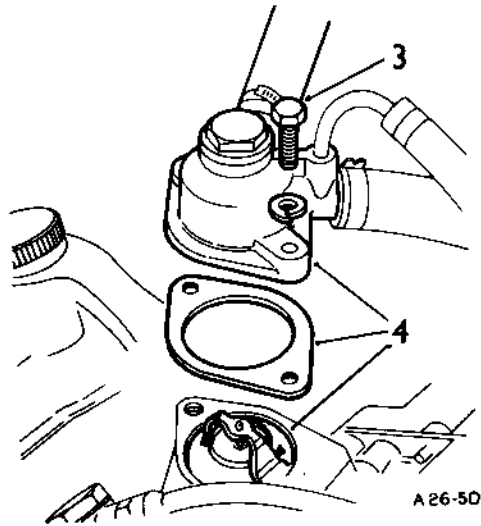

## THERMOSTAT

Test

26.45.10

- 1 Remove the thermostat. 26.45.01.
- 2 Note the temperature stamped on the thermostat at which it should be fully open.
- 3 Place the thermostat and a centigrade thermometer in a laboratory beaker and heat the water, observe the temperature at which the thermostat opens.
- 4 Refit or renew the thermostat as necessary. 26.45.01—instructions 5 to 8.

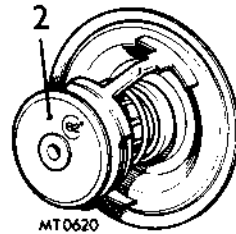
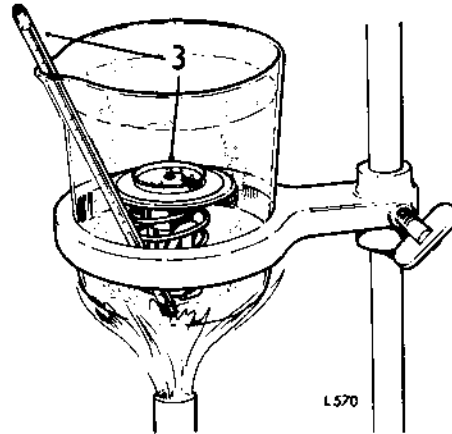

## WATER PUMP

Remove and refit

26.50.01

Service tools S4235A/10, 4235A.

**WARNING:** This operation must only be carried out when the engine is cool.

- 1 Disconnect the battery.
- 2 Remove the inlet manifold complete with carburettors. 30.15.02.
- 3 Remove the connecting tube from the water-pump cover.
- 4 Disconnect the bottom hose from the water pump cover.
- 5 Remove the three bolts securing the pump cover to the cylinder block.
- 6 Lift off the pump cover complete with gaskets.
- 7 Using a spanner on the impeller centre bolt turn clockwise until either:
  - a the water pump is released from the jackshaft gear and can be withdrawn.
  - or
  - b the centre bolt is removed.
- 8 If (b) applies fit special tool S4235A/10 and 4235A impact tool and adaptor to remove the pump.

*continued*

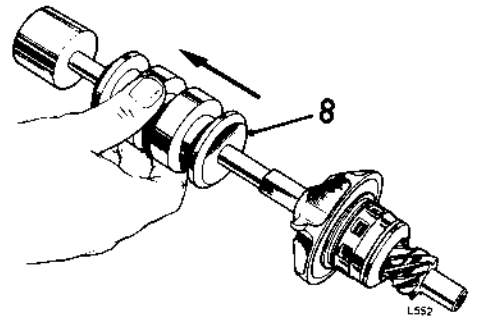
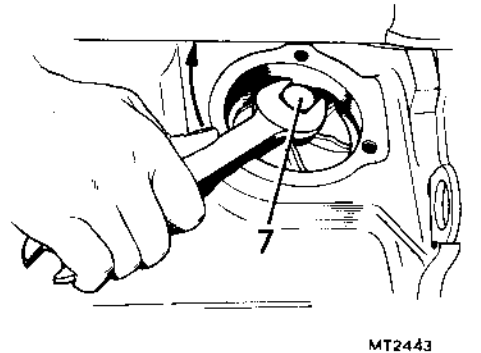
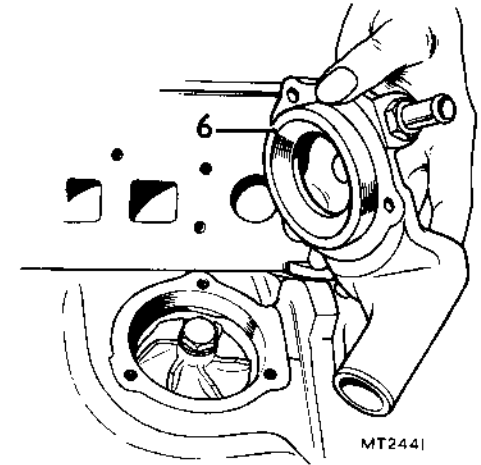
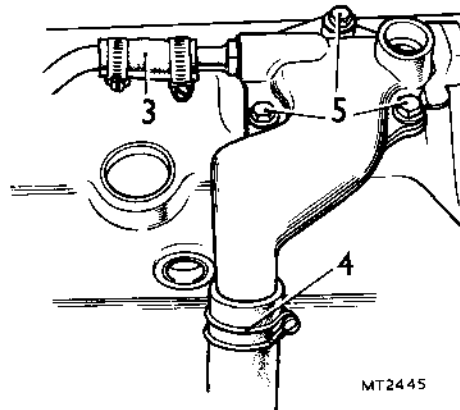

**Refitting**

9 Fit the pump into the cylinder block housing, ensuring that the pump and jackshaft gears mesh correctly and that the pump is properly seated. Check by turning the impeller centre bolt anti-clockwise.

**CAUTION:** The use of force or impact to seat the pump will damage the pump and graphite seal.

10 Ensure that the cylinder block housing and mating faces are clean.

11 Temporarily fit the pump cover leaving the three bolts finger tight.

12 Using feeler gauges check and note that the gap between the pump cover and cylinder block is equal. Equalize the gap by adjusting the bolts.

13 Select water pump gaskets to equal the gap noted in instruction 12 plus 0.010 in to 0.025 in (0.25 to 0.5 mm) to obtain the correct running clearance.

**NOTE:** Water pump gaskets are available in the following thicknesses, 0.010, 0.020, 0.030 in.

14 Remove the pump cover, fit the selected gaskets, fit the cover and tighten the bolts evenly to the correct torque figure—see section 06.

15 Refit the inlet manifold complete with carburetters. 30.15.02.

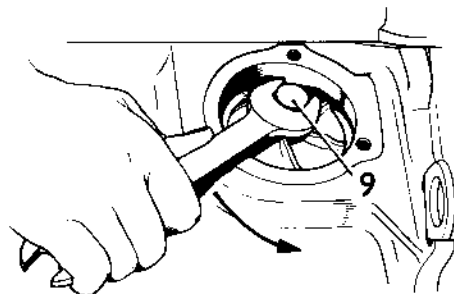

MT2443A

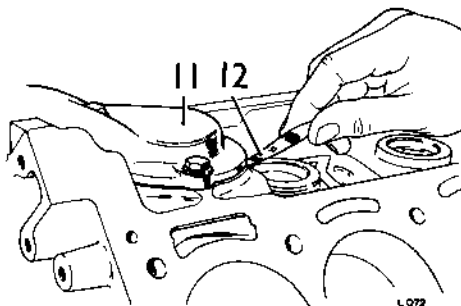

L079

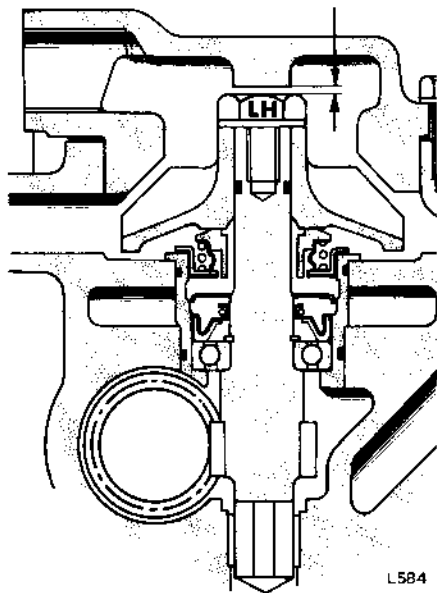

L584

**WATER PUMP****Overhaul****26.50.06**

Service Tool Kit: S348

**Dismantling**

- 1 Remove the water pump. 26.50.01.
- 2 Remove the centre bolt—noting that it has a left-hand thread.
- 3 Insert the assembly into the large hole of special tool S348/1.
- 4 Using a special tool S348/6 drift the unit from the impeller.
- 5 Insert the assembly, gear uppermost, into the small hole of tool S348/1.
- 6 Drift the unit from the housing.

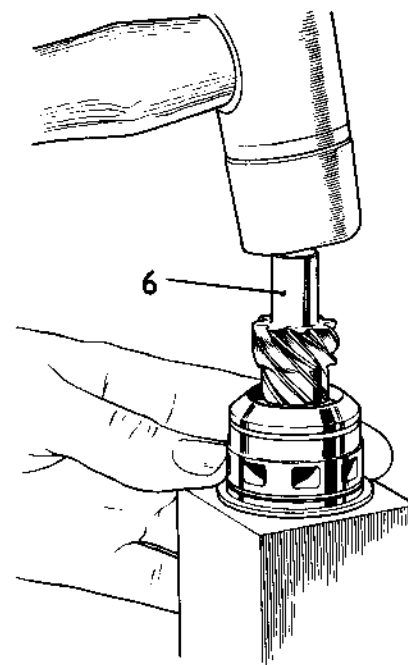

L558

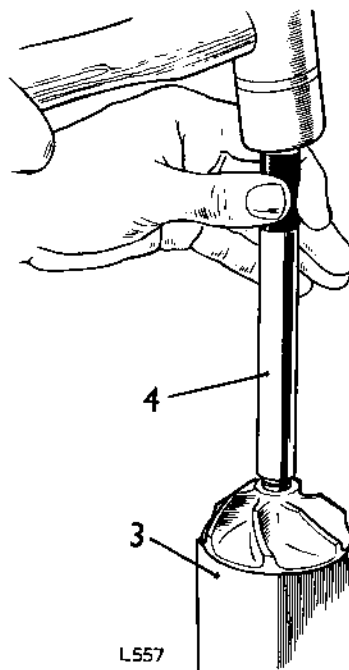

L557

- 7 Remove from the shaft in the following order:

- a 'O' ring.
- b graphite seal.
- c water flinger.
- d oil seal.
- e circlip.



- 8 Insert the shaft, gear downwards, into tool S348/7.
- 9 Drift the shaft from the bearing.
- 10 Remove the oil flinger.
- 11 Remove the 'O' rings from the housing.
- 12 Discard the 'O' rings, seals and bearing.

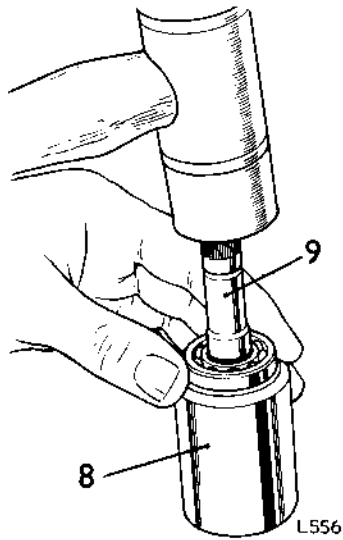

#### Assembling

- 14 Fit the oil flinger to the shaft dished face towards the gear.
- 15 Fit the bearing to the shaft using tool S348/7.
- 16 Fit the circlip ensuring that it seats correctly.

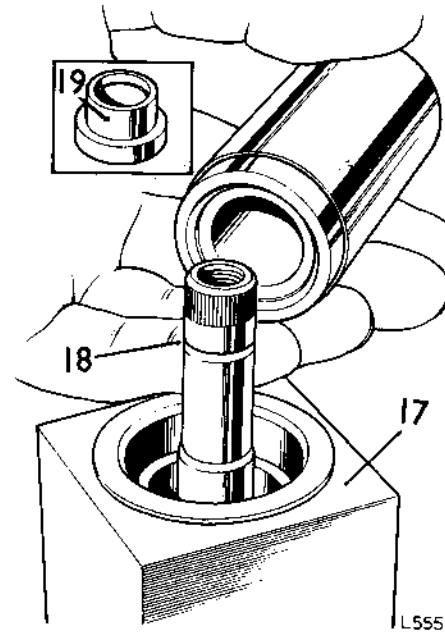
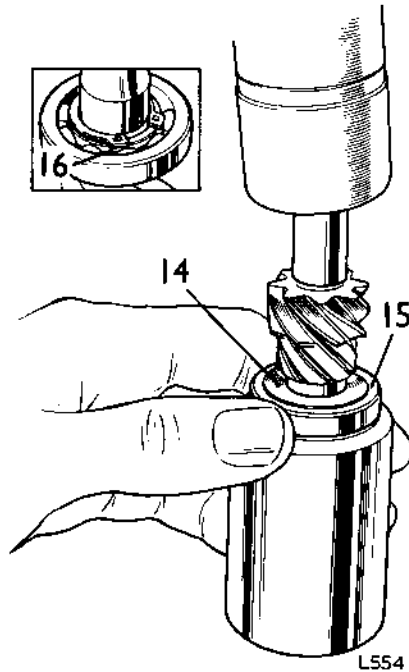

- 17 Fit the water pump body into the small hole in tool S348/1.
- 18 Fit the shaft unit, gear downwards, into the housing and using tool S348/2 gently drift into position.
- 19 Fit the oil seal, flat face towards the bearing.

#### Examination

- 13 Inspect the shaft, housing and impeller for serviceability and renew if necessary.

- 20 Fit the water flinger, dished face towards the bearing using tool S348/2.

**CAUTION:** The water flinger will seat on the shoulder of the shaft. Excessive force applied when fitting, will cause distortion and fouling of the water-pump body.

- 21 Fit the graphite seal, flat face downwards, over the shaft and seating in the housing.
- 22 Fit the 'O' ring to the shaft.
- 23 Press the impeller on to the shaft.
- 24 Fit the centre bolt and washer (left-hand thread) and tighten to the correct torque – see 'TORQUE WRENCH SETTINGS'.
- 25 Fit the two 'O' rings to the water pump housing, smaller one nearest to the gear.
- 26 Refit the water pump. 26.50.01.

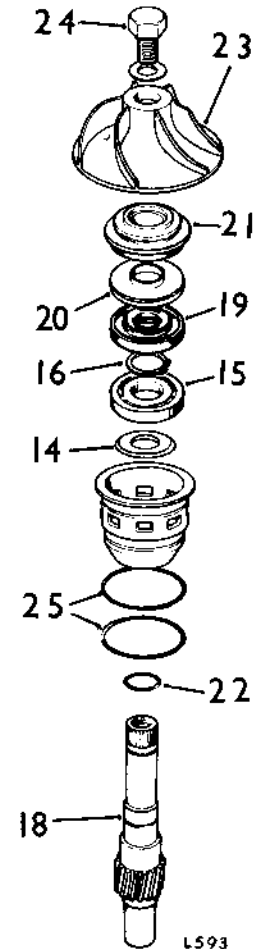

**FRONT PIPE**

Remove and refit 30.10.09

**Removing**

- 1 Drive the car on to a ramp.
- 2 Raise the ramp.
- 3 Slacken the silencer to down-pipe clamp bolt.
- 4 Un-hook the silencer from its body hanger.

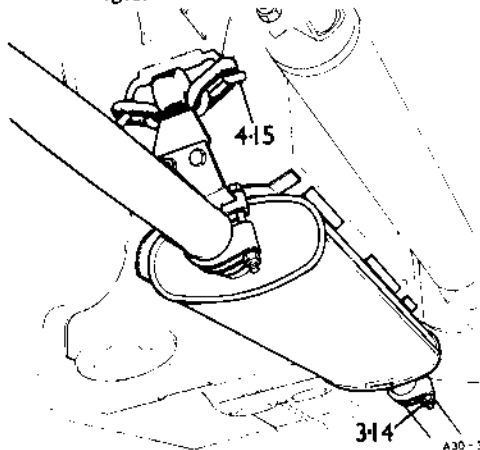

- 5 Un-hook the tail-pipe from its hanger.
- 6 Drive the silencer from the down-pipe.
- 7 Remove the nut and bolt securing the rear-end of the down pipe.
- 8 Remove the two nuts and bolts retaining the front end of the pipe.
- 9 Remove the three bolts securing the down-pipe to the manifold flange.

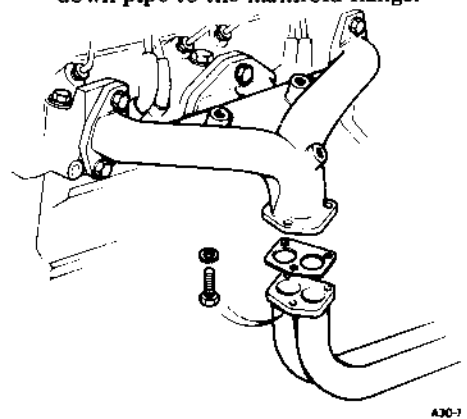

- 10 Remove the pipe complete with gasket.

**Refitting**

- 11 Fit the down pipe to the manifold flange using a new gasket.
- 12 Secure the pipe to the front bracket using the two nuts and bolts.
- 13 Connect the pipe to its rear mounting with the single nut and bolt.
- 14 Fit the silencer to the down-pipe leaving the clamp slack.
- 15 Fit the silencer to its body hanger.
- 16 Secure the tail pipe to its hanger.
- 17 Tighten the silencer front clamp bolt.
- 18 Lower the ramp.

**SILENCER – FRONT**

Remove and refit 30.10.14

**Removing**

- 1 Raise the car on a ramp.
- 2 Release the clips clamping the silencer to the tail and down-pipes.

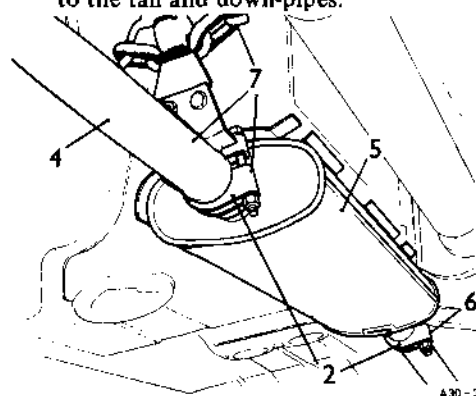

- 3 Disconnect the tail pipe from the body.
- 4 Withdraw the tail pipe assembly from the silencer.
- 5 Withdraw the silencer from the front-pipe.

**Refitting**

- 6 Fit the silencer to the front-pipe and tighten the retaining clip.
- 7 Fit the tail pipe assembly to the silencer and attach it to the body. Tighten the tail-pipe to silencer clip.
- 8 Lower the ramp.

**TAIL-PIPE AND REAR SILENCER**

Remove and refit 30.10.22

**Removing**

- 1 Raise the car on a ramp.
- 2 Release the clip clamping the tail-pipe to the silencer.
- 3 Unhook the tail-pipe from its forward hanger.
- 4 Unhook the tail-pipe from its rear hanger.
- 5 Withdraw the tail-pipe from the silencer.
- 6 Remove the two nuts and bolts securing the hanger bracket assembly to the tail-pipe bracket, and separate the two assemblies.

**Refitting**

- 7 Fit the hanger bracket assembly to the tail-pipe bracket with the two nuts and bolts.
- 8 Fit the tail-pipe to the silencer.
- 9 Hang the tail-pipe to its forward and rear hanger brackets using, if necessary, new rubbers.
- 10 Tighten the silencer-to-tail-pipe clamp bolt.
- 11 Lower the ramp.

**FRONT PIPE FLANGE GASKET**

Remove and refit 30.10.26

**Removing**

- 1 Raise the car on a ramp.
- 2 Remove the three front-pipe to manifold flange retaining bolts.

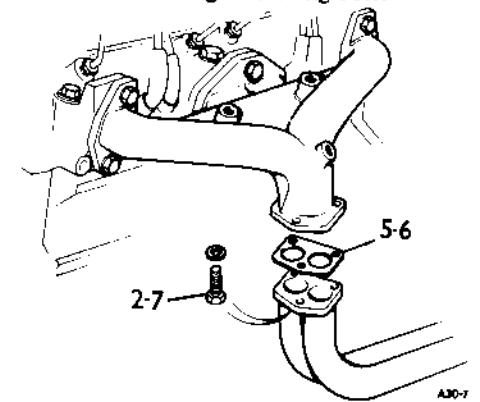

- 3 Remove the two nuts and bolts securing the down-pipe to its suspension bracket.
- 4 Remove the nut and bolt securing the intermediate pipe to its bracket.
- 5 The down-pipe will now drop sufficiently to remove the gasket.

**Refitting**

- 6 Insert the gasket into position.
- 7 Fit the flange manifold bolts but leave slack.
- 8 Fit the two nuts and bolts securing the down-pipe to its bracket, but leave slack.
- 9 Fit and tighten the nut and bolt retaining the intermediate pipe to its bracket.
- 10 Tighten the flange bolts to the correct torque – see 'TORQUE WRENCH SETTINGS'.
- 11 Tighten the front-pipe bracket bolts.
- 12 Lower the ramp.

**EXHAUST MANIFOLD – UK and Europe**

Remove and refit 30.15.01

**Removing**

- 1 Drive the car on to a ramp and disconnect the battery.
- 2 Raise the ramp and remove the three bolts securing the exhaust front-pipe to the manifold.
- 3 Remove the four manifold lower retaining bolts.
- 4 Lower the ramp.
- 5 Remove the three manifold top retaining bolts and lift-off the manifold.

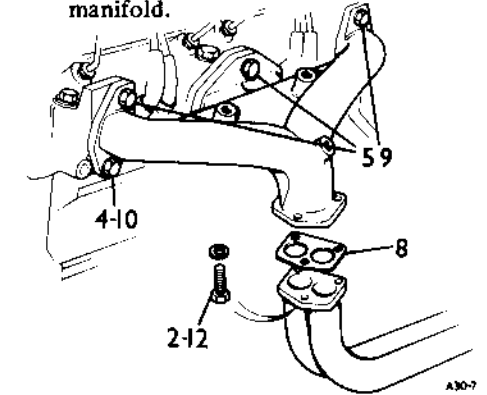

### Refitting

- Place a new front pipe to manifold gasket in position.
- Fit the manifold securing it loosely with the three top bolts.
- Raise the ramp and fit the four lower retaining bolts.
- Finally tighten the manifold bolts evenly to the correct torque – see 'TORQUE WRENCH SETTINGS'.
- Fit and tighten the three front-pipe to manifold bolts.
- Lower the ramp and reconnect the battery.

### EXHAUST MANIFOLD – USA & Canada Specification Vehicles

Remove and refit 30.15.01

#### Removing

- Drive the car on to a ramp and disconnect the battery.
- Raise the ramp and remove the three bolts securing the exhaust front-pipe to the manifold.
- Remove the manifold four lower retaining bolts.
- Lower the ramp and remove the hot air hose from the manifold.
- Remove the three manifold top retaining bolts and lift-off the manifold.
- Withdraw the three bolts and remove the hot air collection pressing.

#### Refitting

- Fit the hot air collection pressing to the manifold.
- Place the new front pipe to manifold gasket in position.
- Fit the manifold securing it loosely with the three top bolts.
- Raise the ramp and fit the four lower retaining bolts.
- Finally tighten the manifold bolts evenly to the correct torque – see 'TORQUE WRENCH SETTINGS'.
- Fit and tighten the three front-pipe to manifold bolts.
- Lower the ramp and fit the hot air hose.
- Reconnect the battery.

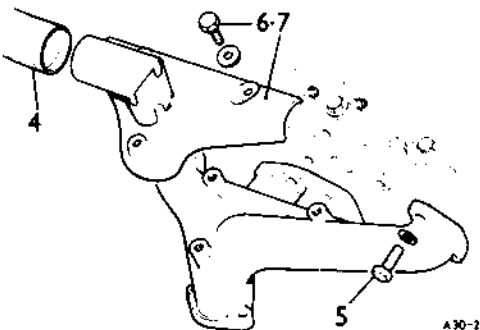

### INDUCTION MANIFOLD

Remove and refit 30.15.02

#### Removing

- Disconnect the battery.
- Drain the cooling system. 26.10.01.
- Remove the fresh air duct. 80.15.31.
- Remove the air cleaner. 19.10.02.
- Disconnect the top water hoses from the engine.
- Disconnect the water temperature transmitter lead.
- Disconnect the main fuel feed to the carburetters.
- Disconnect the brake servo hose from the manifold.
- Disconnect the mixture control cable from the front carburetter. – Not U.S.A.
- Pull-off the spill pipe from the rear carburetter float chamber.
- Disconnect the throttle cable from the carburetter linkage.
- Pull-off the breather hose from the camshaft cover.
- Remove the distributor cap.
- Pull-off the distributor vacuum pipe from the rear carburetter.
- Remove the six manifold attachment bolts and remove the engine lifting bracket.
- Disconnect the heater pipe at union with the induction manifold.
- Lift the manifold complete with carburetters from the engine.
- Remove the 'O' ring between manifold and cylinder head.
- Remove the connecting tube.
- Remove the gasket.
- Disconnect the engine breather pipes from the carburetters.
- Disconnect the throttle linkage springs from the manifold bracket.
- Remove the bolts retaining the throttle linkage bracket to the manifold.
- Remove the eight nuts securing the carburetters to the manifold (four per carburetter).
- Withdraw the carburetters and gaskets.
- Remove the throttle jack bracket.
- Remove the rubber mountings and gaskets.

- NOTE:** If the manifold is to be renewed remove the following items:—
- Remove the two bolts and lift-off the thermostat housing cover.
  - Withdraw the thermostat.
  - Remove the two bolts and remove the common throttle spring and breather pipe bracket.
  - Remove the water temperature transmitter.
  - Remove the brake servo pipe banjo.
  - Remove the banking plug.

#### Refitting

- Reverse instructions 28 to 33.
- Using new gaskets fit the rubber mountings.
- Fit the throttle jack bracket.
- Fit the carburetters using new gaskets, and secure with eight nuts and spring washers.
- Fit the throttle linkage bracket to the manifold.
- Connect the throttle linkage springs.
- Connect the engine breather pipes to the carburetters.
- Place a new gasket in position on the manifold face.
- Fit a new 'O' ring to the manifold.
- Fit the manifold complete with carburetters and engine lifting bracket and secure with the six bolts, tightening evenly to the correct torque.
- Connect the heater pipe at the union with the induction manifold.
- If fitted, remove the thermostat housing cover and withdraw the thermostat.
- Insert the connecting tube squarely through the thermostat housing until fully home.
- Refit the thermostat and cover using a new gasket.
- Reverse instructions 1 to 14.

## CLUTCH ASSEMBLY

Remove and refit 33.10.01

### Removing

- 1 Remove the gearbox. 37.20.01
- 2 Evenly slacken and remove the six bolts and spring washers securing the clutch to the engine flywheel.  
**NOTE:** If the clutch is to be refitted, scribe or mark clutch and flywheel to identify original relationship.
- 3 Remove the clutch assembly and drive plate.

### Refitting

- 4 Using a substitute first motion shaft offer up the drive plate to the flywheel. Note that the longer boss of the drive plate must be adjacent to the gearbox.
- 5 Engage the clutch assembly on the flywheel dowels. Fit the six securing bolts and spring washers and tighten evenly to the correct torque – see 'TORQUE WRENCH SETTINGS'.
- 6 Remove the substitute first motion shaft.
- 7 Fit the gearbox. 37.20.01.

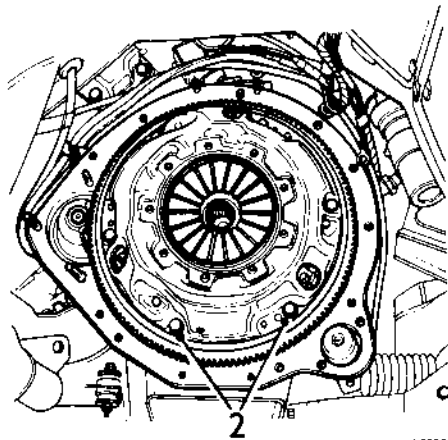

A 33001

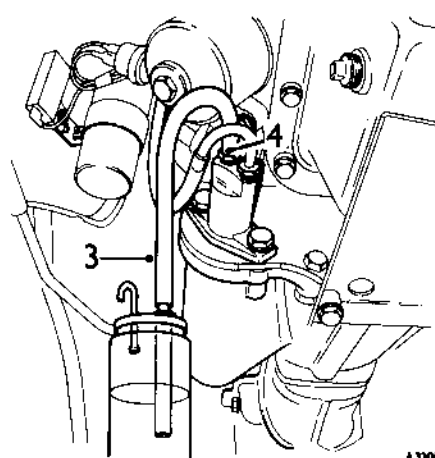

A 33003

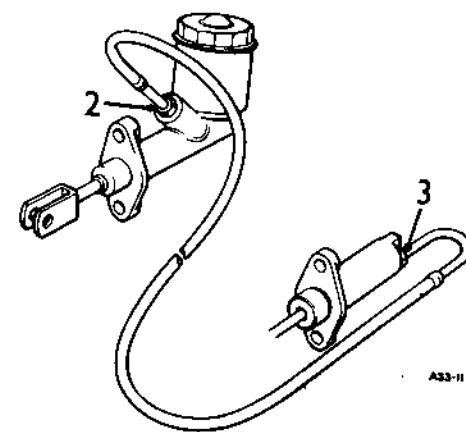

A 33-11

## FLUID PIPE

Remove and refit 33.15.09

### Removing

- 1 Drain the hydraulic system.
- 2 Unscrew the pipe from the master cylinder.
- 3 Unscrew the pipe from the slave cylinder.
- 4 Remove the pipe from the car.

### Refitting

- 5 Align the new pipe in the approximate position in the car.
- 6 Screw the pipe into the master cylinder.
- 7 Screw the pipe into the slave cylinder.
- 8 Top up the master cylinder with new brake fluid.
- 9 Bleed the system. 33.15.01.

## HYDRAULIC SYSTEM

Bleeding 33.15.01

- 1 Thoroughly clean the areas in the vicinity of the master cylinder reservoir filler cap and the slave cylinder bleed nipple.
- 2 Ensure that the master cylinder reservoir is topped up.
- 3 Attach one end of a bleed tube to the slave cylinder bleed nipple and immerse the other end in a transparent vessel containing brake fluid.
- 4 Open the bleed nipple approximately three-quarters of a turn. Depress and release the clutch pedal, pausing momentarily at each down stroke until fluid free of air issues from the slave cylinder. Close the bleed nipple with pedal depressed and release the pedal.  
Care must be taken to ensure that the level of fluid in the master cylinder reservoir is never permitted to fall to less than half capacity.
- 5 Remove the bleed tube and top up the reservoir.

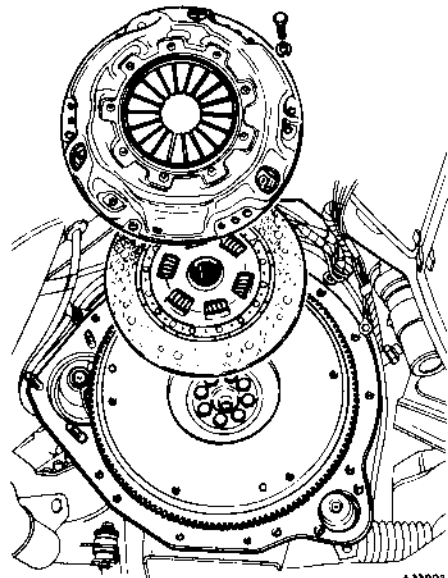

A 33002

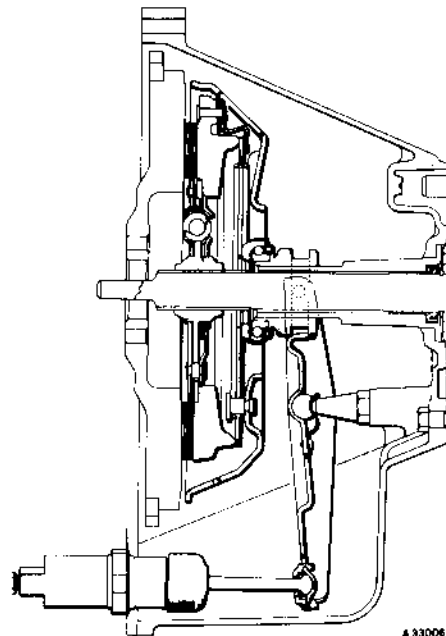

A 33006

## DRIVE PLATE

Remove and refit 33.10.02

As operation 33.10.01.

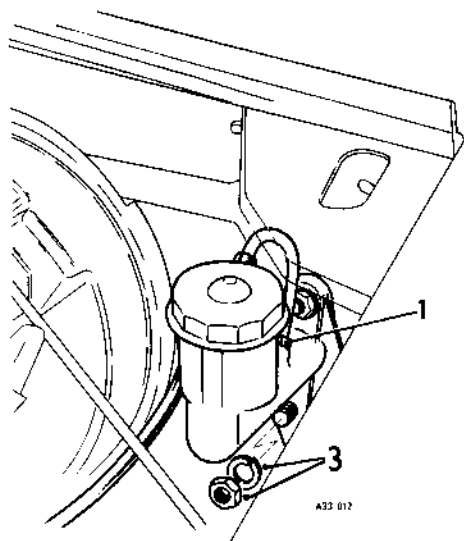

## MASTER CYLINDER

Remove and refit 33.20.01

### Removing

- 1 Unscrew the pipe from the master cylinder.  
**CAUTION: Plug the master cylinder outlet and the end of the pipe to prevent spillage of fluid.**
- 2 Remove the split pin, washer and clevis pin securing the push rod to the clutch pedal.
- 3 Remove the two nuts, spring washers and bolts securing the master cylinder to the body.
- 4 Withdraw the master cylinder.

### Refitting

- 5 Reverse instructions 1 to 4.
- 6 Bleed the system. 33.15.01.

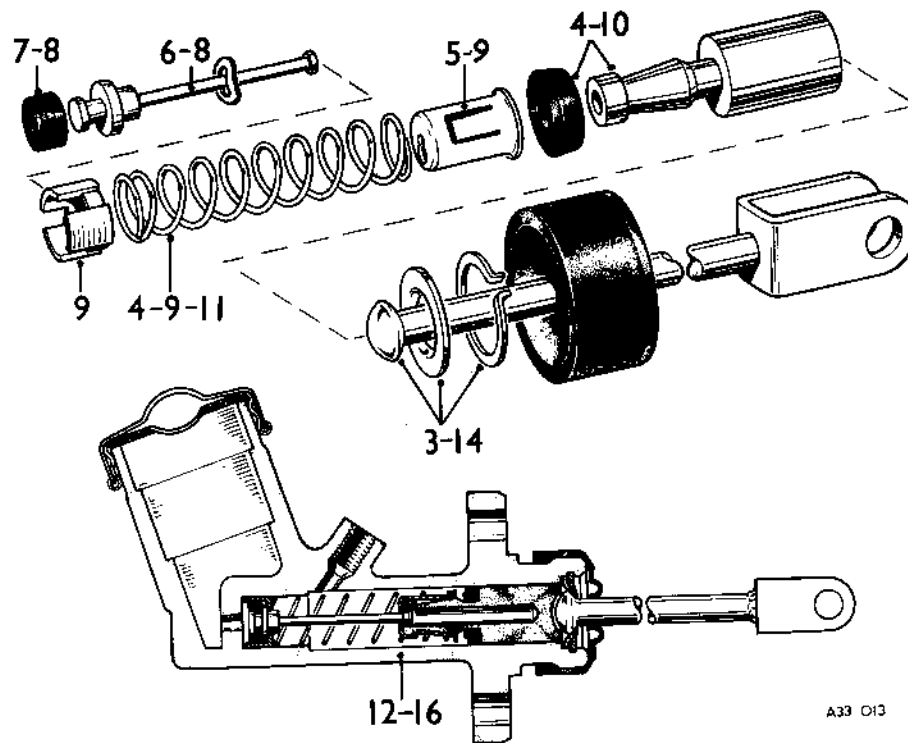

## MASTER CYLINDER

Overhaul 33.20.07

- 1 Remove the master cylinder. 33.20.01.
- 2 Slide the rubber along the push-rod.
- 3 Remove the circlip from the end of the master cylinder and withdraw the push-rod and washer.
- 4 Withdraw the piston spring and seal assembly from the master cylinder. Withdrawal may be facilitated by applying a compressed air line to the fluid outlet union.
- 5 Straighten the prong of the spring thimble and remove the thimble and spring from the piston.
- 6 Release the valve stem from the keyhole slot in the thimble.
- 7 Slide the valve seal spacer along the valve stem.
- 8 Remove the valve seal from the valve stem and fit a new seal.
- 9 Assemble the spacer, spring and thimble to the valve stem.
- 10 Remove the seal from the piston and fit a new seal (seal lip towards the spring).
- 11 Engage the spring thimble on the piston and carefully depress the thimble prong.
- 12 Lubricate the bore of the master cylinder with clean brake fluid and insert the seal assembly spring and piston.
- 13 Fit a new rubber to the push-rod.
- 14 Fit the push-rod and washer to the master cylinder and secure with the clip.
- 15 Slide the rubber into position on the master cylinder.
- 16 Refit the master cylinder. 33.20.01.
- 17 Bleed the system. 33.15.01.

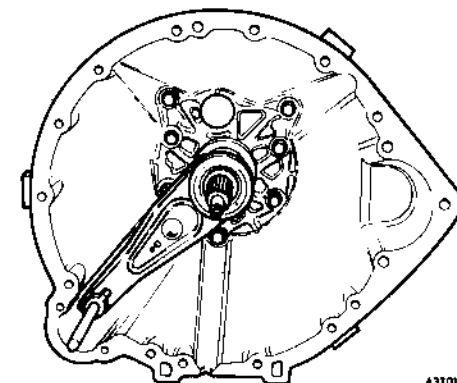

## RELEASE BEARING ASSEMBLY

Remove and refit 33.25.12

Service tools: ST 1136

### Removing

- 1 Remove the gearbox. 37.20.01.
- 2 Using Tool ST 1136 unscrew the clutch release lever pivot bolt from the clutch housing.
- 3 Withdraw the release lever complete with pivot bolt and the release bearing.
- 4 Detach the release bearing from the release lever.

### Refitting

- 5 Offer up the release bearing to the release lever ensuring that the rectangular slippers engage the bearing collar.
- 6 Slide the bearing complete with release lever and pivot bolt into position in the clutch housing.
- 7 Engage the pivot bolt in the clutch housing.
- 8 Using Tool ST 1136, tighten the pivot bolt.
- 9 Fit the gearbox to the car. 37.20.01.

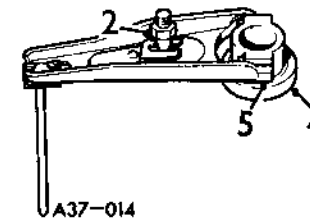

A37-014

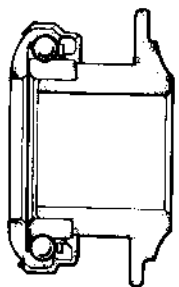
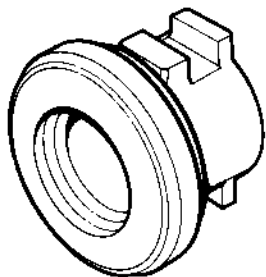

A33 9

### RELEASE BEARING

Overhaul 33.25.17

#### Removing

- 1 Remove the release bearing assembly. 33.25.12.
- 2 Mount the assembly in a press and extract the sleeve from the bearing.

#### Refitting

- 3 Stand the sleeve on its collar end and evenly engage the new release bearing on the sleeve. (Release face of bearing uppermost.)
- 4 Press the bearing onto the sleeve until it abuts against the sleeve shoulder.  
**CAUTION:** The bearing *must not* be assembled to the sleeve by applying a load to the slit, outer race.
- 5 Fit the release bearing assembly to the gearbox. 33.25.12.

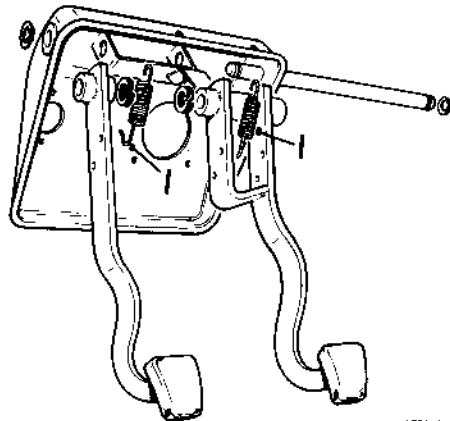

A70008

### CLUTCH AND BRAKE PEDAL ASSEMBLY

Remove and refit 33.30.01

As operation 70.35.03.

### CLUTCH PEDAL RETURN SPRING

Remove and refit 33.30.03

#### Removing

- 1 Release the spring ends from the clutch pedal and pedal bracket.

#### Refitting

- 2 The longer leg of the spring attaches to the clutch pedal. Engage the spring hook in the pedal bracket then clip the other hook through the drilling in the clutch pedal.

### CLUTCH AND BRAKE PEDAL ASSEMBLY

Overhaul 33.30.06

As operation 70.35.04.

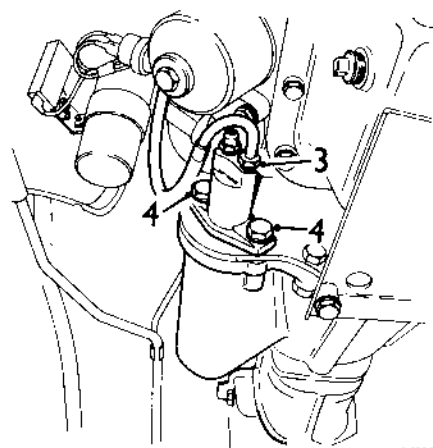

A33004

### SLAVE CYLINDER

Remove and refit 33.35.01

#### Removing

- 1 Raise or jack up the car and support securely.
- 2 Clean the slave cylinder removing all loose mud etc. in the vicinity of the fluid pipe and nipple.
- 3 Disconnect the fluid pipe and plug the cylinder and pipe union.
- 4 Remove the two bolts and nuts securing the slave cylinder to the engine.
- 5 Gently withdraw the slave cylinder.

**CAUTION:** When the slave cylinder is removed do not attempt to move the operating push rod in a forward direction as this may cause the clutch release lever to be dislodged, necessitating the removal of the gearbox to permit refitting of the release lever.

#### Refitting

- 6 Reverse instructions 3 to 5. The slave cylinder must be mounted with the bleed nipple *above* the fluid pipe.
- 7 Bleed the system. 33.15.01.
- 8 Lower the car.

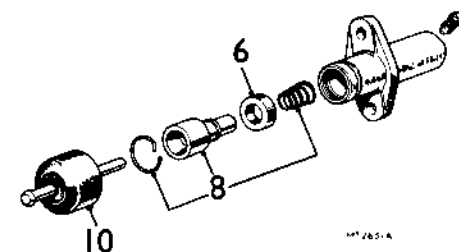

M7481A

### SLAVE CYLINDER

Overhaul 33.35.07

#### Dismantling

- 1 Remove the slave cylinder. 33.35.01.
- 2 Remove the rubber boot.
- 3 Extract the circlip piston, cup and spring.

#### Inspection

- 4 Discard the rubber boot and cup and clean remaining components in clear brake fluid or methylated spirit.
- 5 Carefully examine the piston and cylinder bore. Renew either or both components if there is evidence of corrosion or scoring.

#### Assembling

- 6 Fit a new cup to the piston.
- 7 Lubricate the cylinder bore with clean brake fluid.
- 8 Fit the smaller diameter of the spring to the piston and fit the spring (larger diameter leading) piston and cup into the cylinder. Fit the circlip.
- 9 Smear the piston and bore with disc brake lubricant or rubber grease.
- 10 Fit the rubber boot.
- 11 Refit the slave cylinder. 33.35.01.
- 12 Bleed the system. 33.15.01.

## DRIVE FLANGE

Remove and refit

37.10.01

Service tools: S337 or 18G 1205

### Removing

- 1 Raise the car and support securely.
- 2 Slacken one bolt securing the propeller shaft safety strap and remove the remaining bolt. Swing the strap clear of the propeller shaft.
- 3 Scribe the relationship of the propeller shaft and gearbox flanges and remove the four securing nuts and bolts.
- 4 Release the propeller shaft from the driving flange.
- 5 Using tool S337 to prevent rotation of the driving flange remove the securing nut and washer.
- 6 Withdraw the driving flange.

### Refitting

- 7 Reverse instructions 1 to 6.  
The drive flange nut should be torqued to: 90-120 lbf ft (12.44-16.60 kgf m).  
Propeller shaft bolts to: 26-34 lbf ft (3.60-4.70 kgf m).

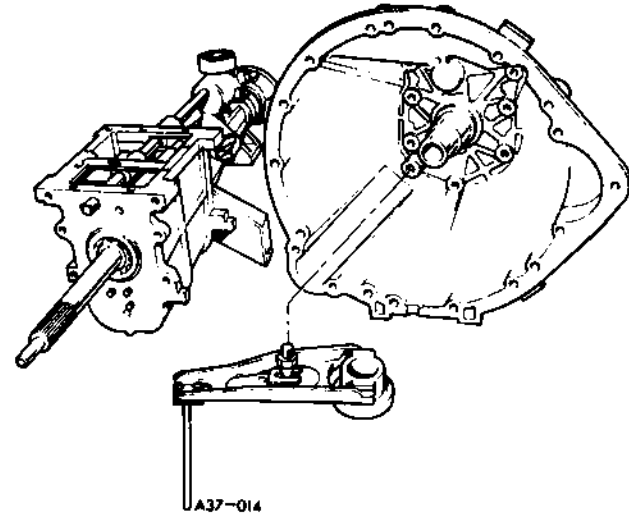
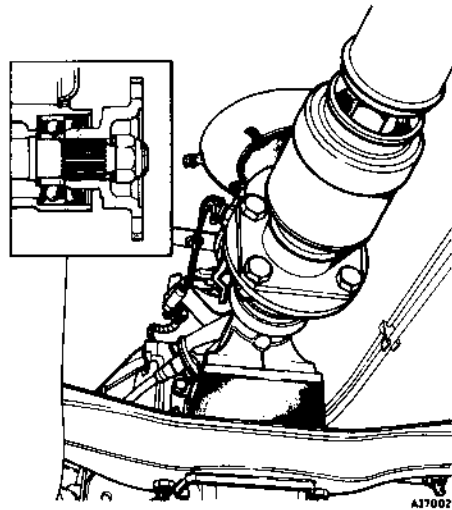

- 7 Remove the speedometer drive pinion, see 37.25.05.
- 8 Using tool S337 to prevent rotation of the driving flange remove the securing nut and washer.
- 9 Withdraw the driving flange.
- 10 Remove the gearbox top cover, gasket and spool plate.
- 11 Locate the gear selector in the reverse gear position and ensure that the selector shaft pins clear the interlock spool and the gear selector forks.

## REAR EXTENSION

Remove and refit

37.12.01

Service tools : S337 or 18G 1205

### Removing

- 1 Raise the car, drain the gearbox and refit the drain plug.
- 2 Remove the gearbox from the car, see 37.20.01.
- 3 Support the gearbox in a vice by means of the drain plug and remove the seat belt interlock switch and reverse switch.
- 4 Remove the clutch housing and gasket, see 37.12.07.
- 5 Withdraw the three springs from the layshaft front thrust washer.
- 6 Carefully drift out the roll pin from the selector rod.

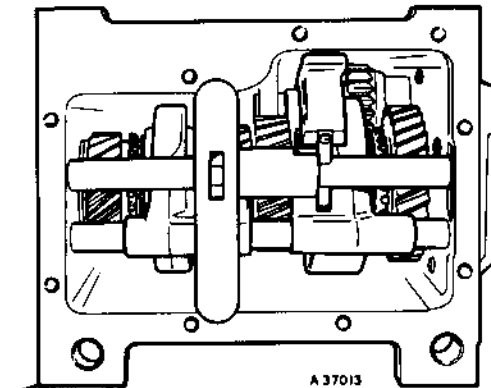
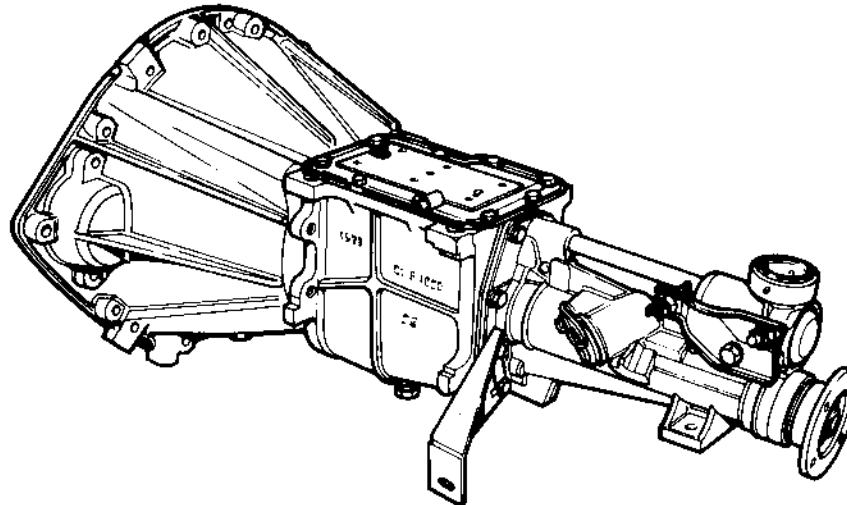

*continued*

A37003

A37013

- 12 Remove the bolts and spring washers securing the rear extension to the gearbox and remove the rear extension exhaust bracket.
- 13 Remove the rear extension from the gearbox. Ensure that the selector pins do not foul and that the layshaft is not displaced. Lift out the interlock spool as the rear extension and selector shaft are withdrawn.
- 14 Remove the gasket.
- 15 Remove the distance washer from the mainshaft.
- 16 Remove the oil seal and bearing from the rear extension case.

#### Refitting

- 17 Ensure that the mating faces of the gear case and rear extension housing are clean.
- 18 Locate a new gasket in position on the rear of the gear case.
- 19 Fit the distance washer to the mainshaft.
- 20 Offer up the rear extension to the gear case and guide the selector rail into position remembering to fit the selector spool.
- 21 Fit the rear extension securing bolts and washers and exhaust bracket and lock plate.
- 22 Fit the rear bearing and a new oil seal to the extension casing.  
The lip of the seal must be fitted towards the gearbox. When installed the seal should be flush with the casing.
- 23 Lubricate the seal lip and running surface of the drive flange. Fit the drive flange, washer and nut. Using tool S337 to prevent flange rotation, torque the nut to 90-120 lbf ft (12.44-16.60 kgf m).
- 24 Fit the roll pin to the front end of the selector rail. This pin must be positioned centrally.
- 25 Fit the speedometer drive pinion, see 37.25.05.
- 26 Fit the seat belt interlock switch and reverse switch.
- 27 Fit the clutch housing, gasket, clutch release fork and bearing, see 37.12.07.

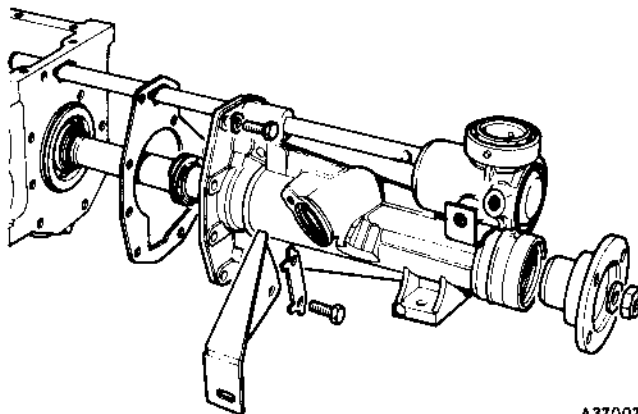

A37007

- 28 Refill the gearbox with fresh lubricant. Ensure drain plug is tight.
- 29 Fit the interlock spool plate, gasket and top cover.
- 30 Fit the gearbox to the car, see 37.20.01.

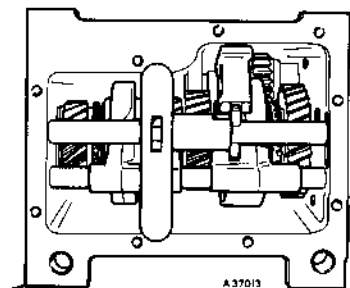

A37013

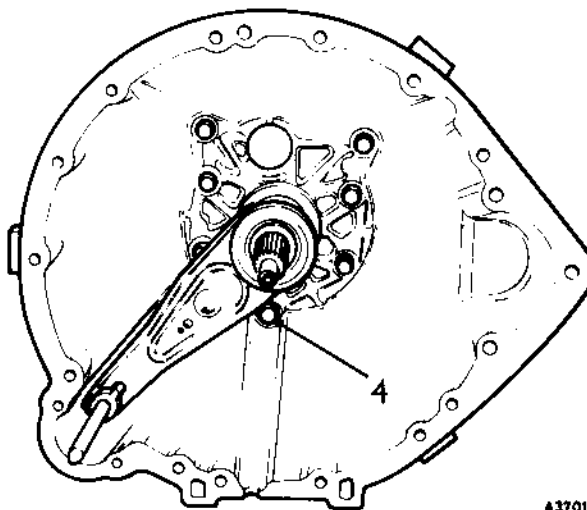

A37012

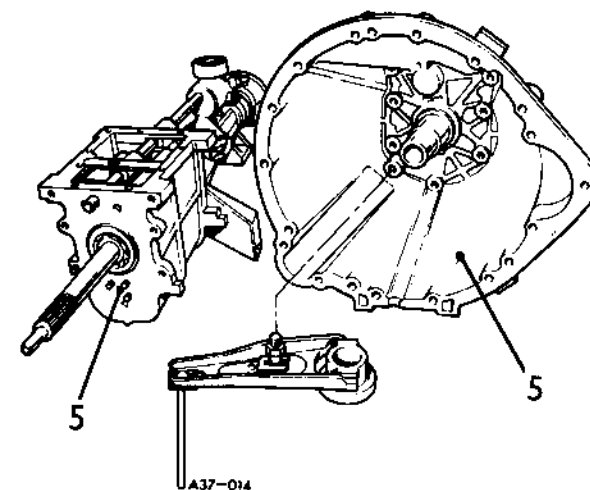

A37-014

## CLUTCH/BELL HOUSING

Remove and refit

37.12.07

### Removing

- 1 Remove the gearbox from the car, see 37.20.10.
- 2 Withdraw the clutch release lever and release bearing, see 33.25.12.
- 3 Tape the splines of the first motion shaft to prevent damage to the oil seal when the clutch housing is withdrawn.
- 4 Remove the seven bolts and washers securing the clutch housing to the gearbox. Note that the lower bolt is fitted with a copper washer; the remaining bolts are fitted with spring washers.
- 5 Withdraw the clutch housing and gasket. Observe that three compression springs are inserted in the front of the gearbox casing to provide a thrust load for the layshaft front bearing.

### Refitting

- 6 Reverse instructions 2 to 5.
- 7 Remove the tape from the splines of the first motion shaft.
- 8 Fit the gearbox to the car, see 37.20.01.



## MAIN CASE

Remove and refit 37.12.40

As operation 37.20.04 but excluding instructions 21 to 25, 27 to 35, and 38.

## GEAR CHANGE LEVER

Remove and refit 37.16.04

### Removing

- 1 Select neutral and unscrew and remove the gear lever knob.
- 2 Remove the two screws securing the gear lever gaiter and top panel assembly to the rear of the console.
- 3 Remove the gear lever gaiter and panel assembly.
- 4 Remove the four screws retaining the gear lever draught excluder and flange assembly.
- 5 Slide the draught excluder flange to the left to clear the console and lift off.
- 6 Release the bayonet cap securing the gear lever to the gearbox extension and lift out the gear lever. Care must be taken not to lose the nylon plunger and spring (anti-rattle) from the gear lever ball swivel.

### Refitting

- 7 Reverse instructions 1 to 6.

## GEAR CHANGE LEVER DRAUGHT EXCLUDER

Remove and refit 37.16.05

As operation 37.16.04 instructions 1 to 5

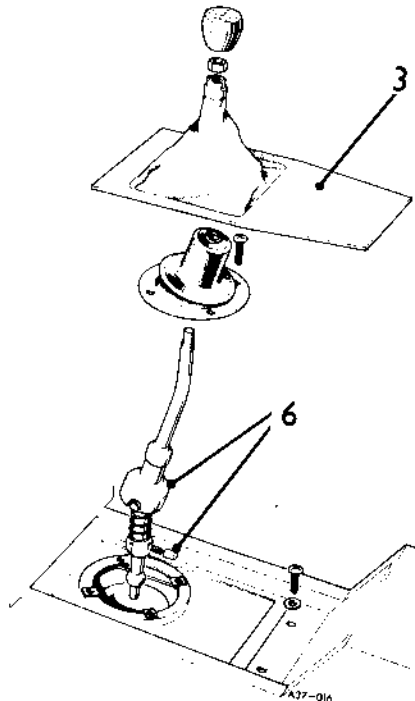
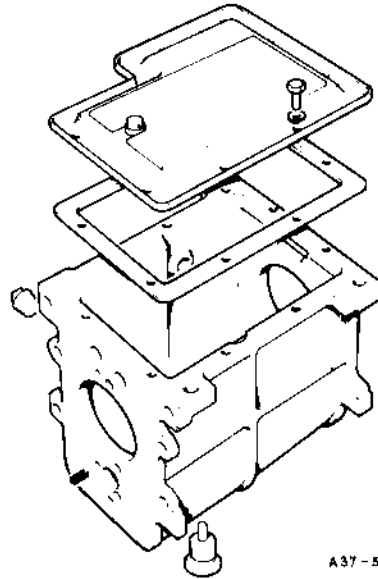

## GEAR CHANGE SELECTORS

Remove and refit 37.16.31

Service tools: S337 or 18G 1205

### Removing

- 1 Remove the gearbox rear extension, see 37.12.01.
- 2 Withdraw the selector fork shaft.
- 3 Lift out the selectors.

### Refitting

- 4 Fit the selectors to the gears.
- 5 Fit the selector shaft.
- 6 Fit the gearbox rear extension, see 37.12.01.

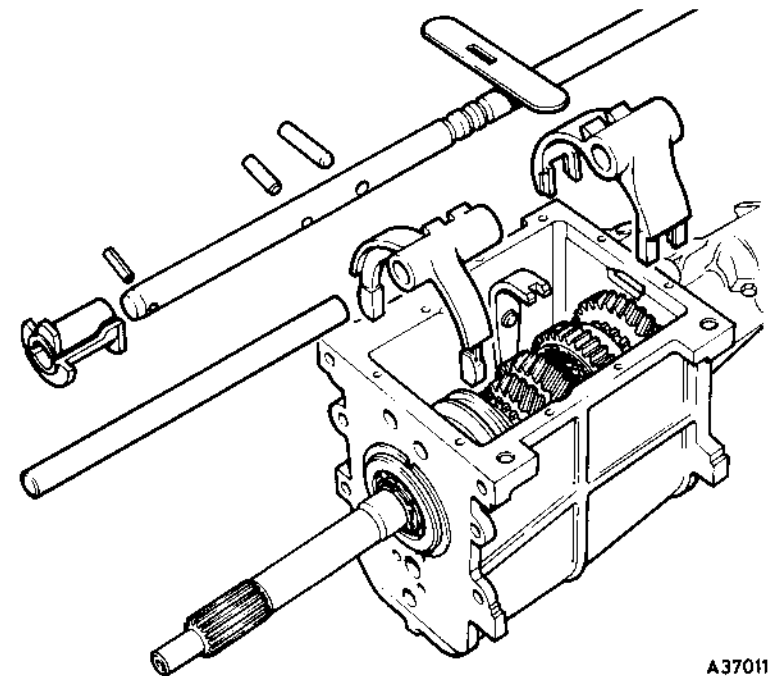
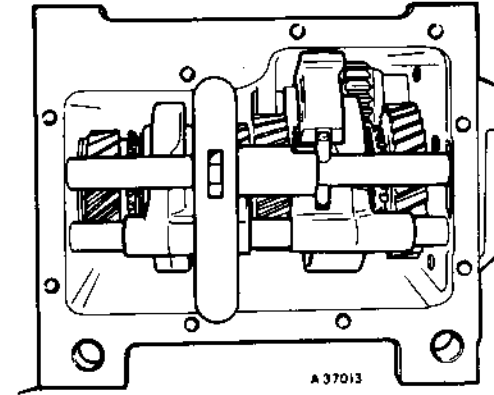

A37011

**GEAR SELECTOR MECHANISM AND HOUSING**

Remove and refit 37.16.37

Service tools: S337 or 18G 1205

**Removing**

- 1 Remove the gearbox rear extension, see 37.12.01.
- 2 Slide the selector shaft rearward until it contacts the rear blanking plug.
- 3 Gently tap the selector shaft to remove the blanking plug.
- 4 Slide the selector shaft rearward until the selector shaft yoke is exposed.

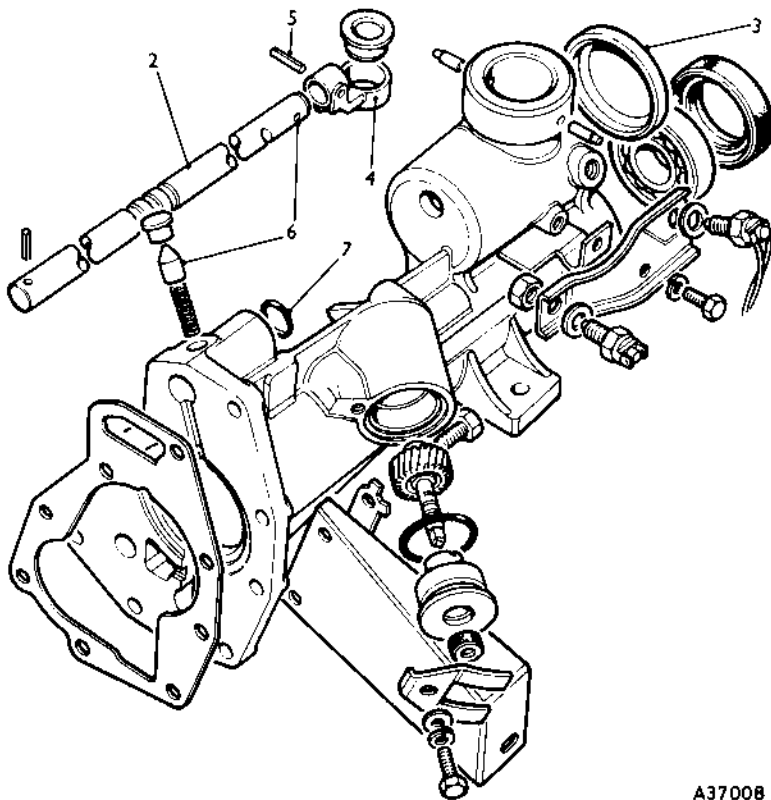

- 5 Remove the roll pin securing the yoke to the shaft and withdraw the yoke.
- 6 Withdraw the selector shaft, moving it towards the front of the rear extension. Ensure that the roll pin hole at the rear of the selector shaft is maintained in an horizontal position to prevent the selector plunger trapping the shaft as it is withdrawn.
- 7 Remove the nylon plug, plunger, spring and 'O' ring from the rear extension casing.

**Refitting**

- 8 Reverse instructions 1 to 7.

**GEARBOX ASSEMBLY**

Remove and refit 37.20.01

**Removing**

- 1 Disconnect the battery.
- 2 Remove the gear lever, see 37.16.04.
- 3 Remove the radiator fan guard.
- 4 Raise the car on a ramp or jack up and support securely.
- 5 Disconnect the propeller shaft at the gearbox flange and tie the propeller shaft so that it will not obstruct gearbox withdrawal.
- 6 Remove the exhaust down pipe, see 30.10.09.
- 7 Disconnect the speedometer cable at the gearbox.
- 8 Disconnect the electrical harness plug to the gearbox.
- 9 Position a jack under the engine sump and support the engine. To avoid damage to the sump a suitable piece of wood should be interposed between the jack pad and the sump.
- 10 Remove the starter motor.
- 11 Remove the clutch slave cylinder. Do not allow the cylinder to hang suspended by the fluid pipe.
- 12 Remove the two bolts securing the sump stiffening plate to the clutch housing.
- 13 Remove the four bolts and nuts securing the gearbox rear mounting bracket to the body.
- 14 Carefully lower the jack to permit access to the clutch housing bolts. Ensure that the water hoses and the engine stabiliser are not strained.
- 15 Remove the bolts and nuts securing the clutch housing to the engine. Note the location of the fitted bolt adjacent to the clutch slave cylinder.
- 16 Carefully withdraw the gearbox ensuring that weight and stress are not imparted to the clutch driving plate.
- 17 Remove the gearbox mounting bracket.

**Refitting**

- 18 Reverse instructions 1 to 17.

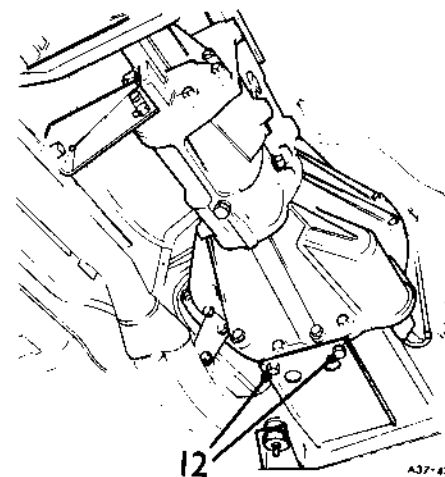
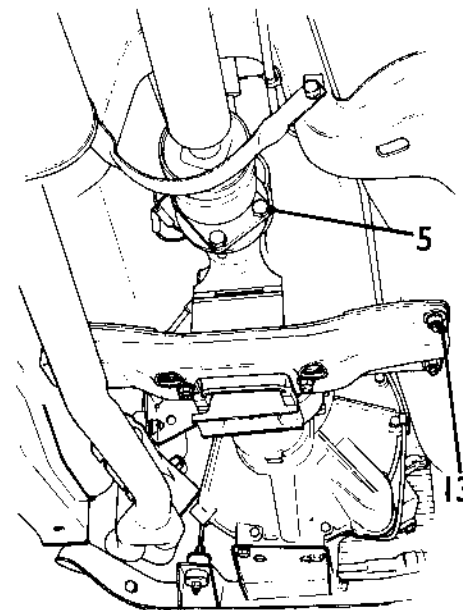

A37008

A37-43

## GEARBOX ASSEMBLY

Overhaul 37.20.04

Service tools: ST1136 47, S337 or 18G 1205, 18G 1208, 18G 1199, S145C, 18G 1197, 3072 or S4235 A, S4235 A-2, 18G 47 BP, 18G 1208, 18G 1198 A

### Dismantling

- 1 Remove the gearbox from the car, see 37.20.01.
- 2 Remove the clutch housing, see 37.12.07.
- 3 Remove the top cover and spool interlock plate.
- 4 Remove the rear extension, see 37.12.01.

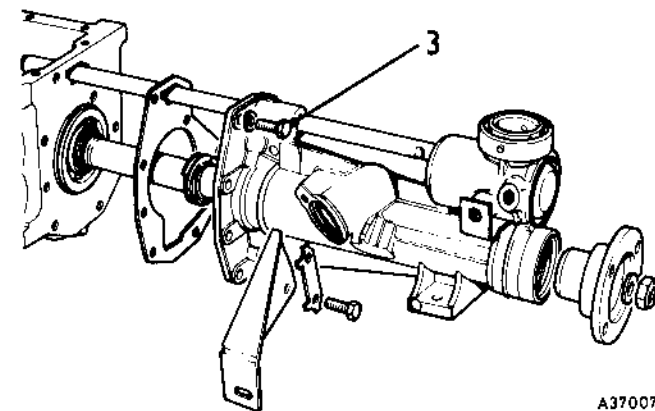
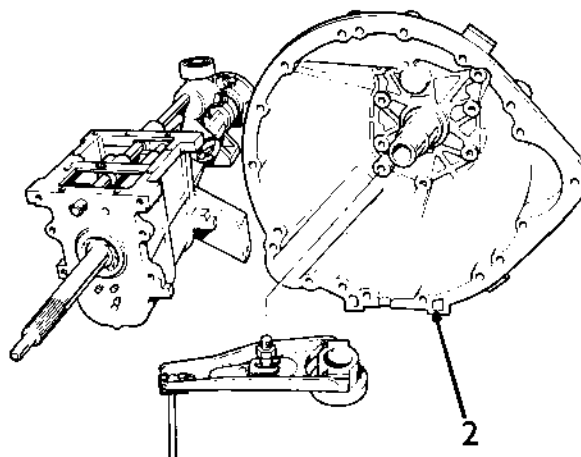
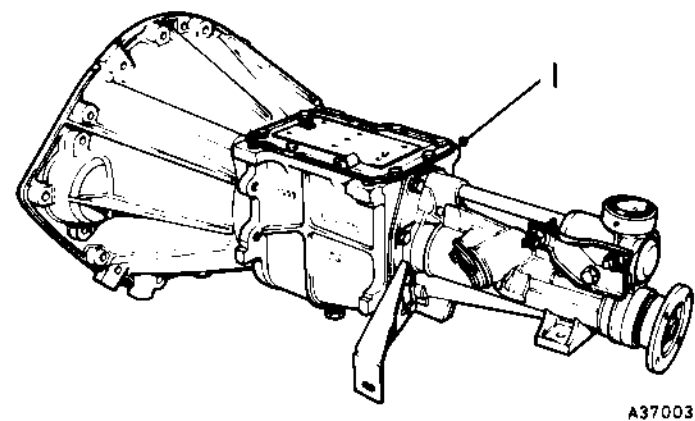
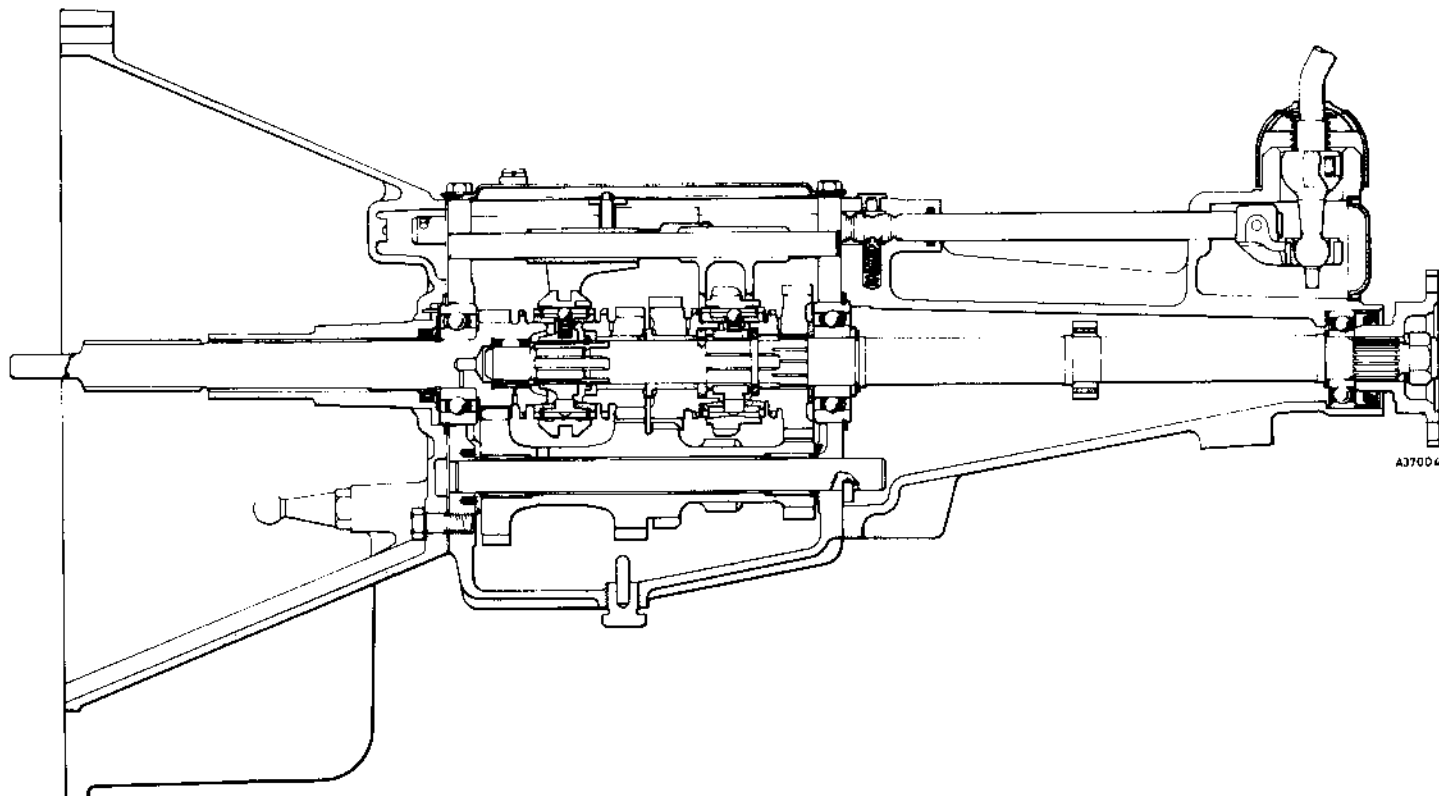
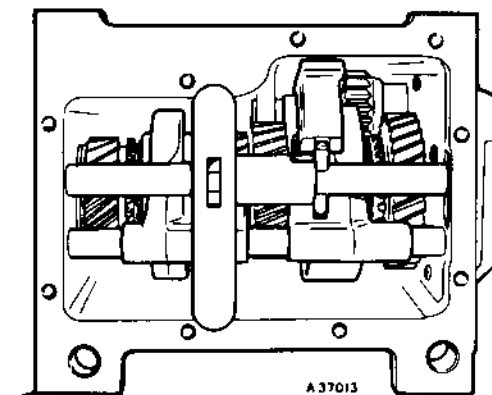

- 5 Remove the gear selector mechanism, see 37.16.37.
- 6 Remove the selector shaft and selector forks.

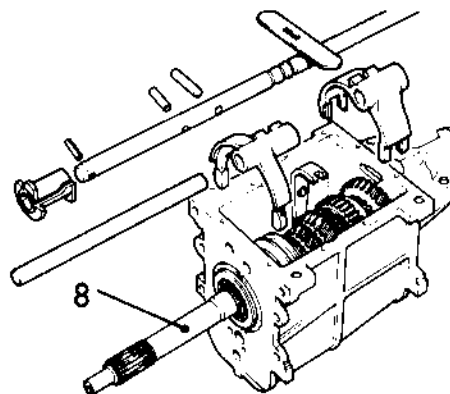

A3701

- 9 Fit the steady bracket of 18G 47 BP to the front of the gear case using two clutch housing bolts. Ensure that the centre adjusting bolt and locknut are fully released before tightening the tool securing bolts.
- 10 Adjust the centre bolt to locate and support the mainshaft spigot. Tighten the locknut.

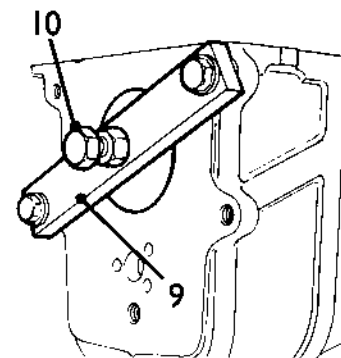

A37-25

- 7 Using tool 18G 1208 displace and remove the layshaft, allowing the laygear to drop to the bottom of the gear case.
- 8 Remove the first motion shaft, see 37.20.16.

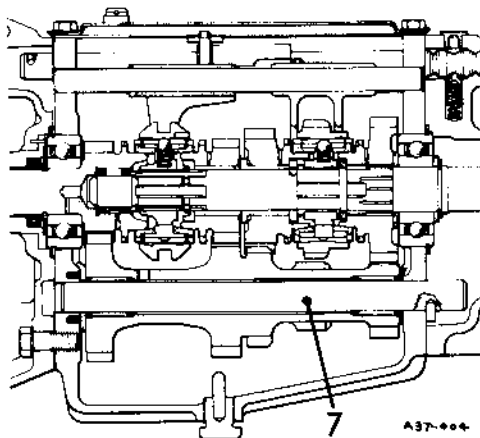

A37-004

- 11 Remove the bolt and spring washer securing the reverse/idler gear spindle.
- 12 Withdraw the reverse/idler gear spindle, and spacer and remove the reverse/idler gear.

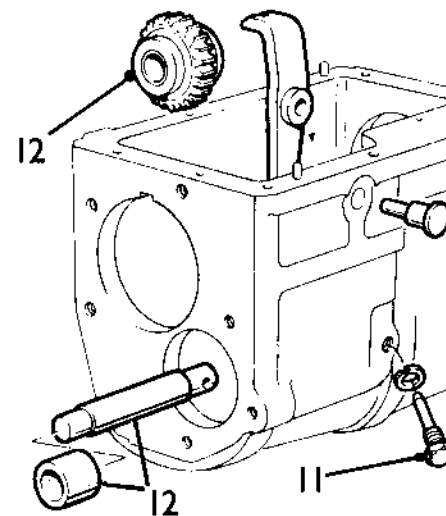

A37-26

- 13 Release the circlip securing the mainshaft bearing to the mainshaft.
- 14 Remove the snap ring fitted to the mainshaft bearing.
- 15 Using tool 47 and bearing remover of 18G 47 BP, remove the mainshaft bearing, selective washer, circlip and speedometer gear from the mainshaft.
- 16 Remove the steady bracket of tool 18G 47 BP from the front of the gear case.
- 17 Tilt the mainshaft and withdraw complete with gears through the top cover aperture.
- 18 Remove the laygear and thrust washers.
- 19 Remove the reverse gear operating lever.
- 20 Remove from the mainshaft.
  - a Thrust washer and 1st speed gear.
  - b 1st speed synchro - cup.
  - c Two, split collars.
  - d 3rd/4th speed synchro-hub and sleeve assembly.
  - e 3rd speed synchro-cup.
  - f Using tool 18G 1199 expand the circlip retaining 3rd speed gear. Carefully lever off 3rd speed gear, and bush, thrust washer, circlip, and tool.
  - g 2nd speed gear and bush.
  - h 2nd speed synchro-cup.
  - i Selective washer.
  - j Using a magnet extract the ball locating the selective washer from its recess in the mainshaft.
  - k 1st/2nd speed synchro-hub and sleeve assembly.

*continued*

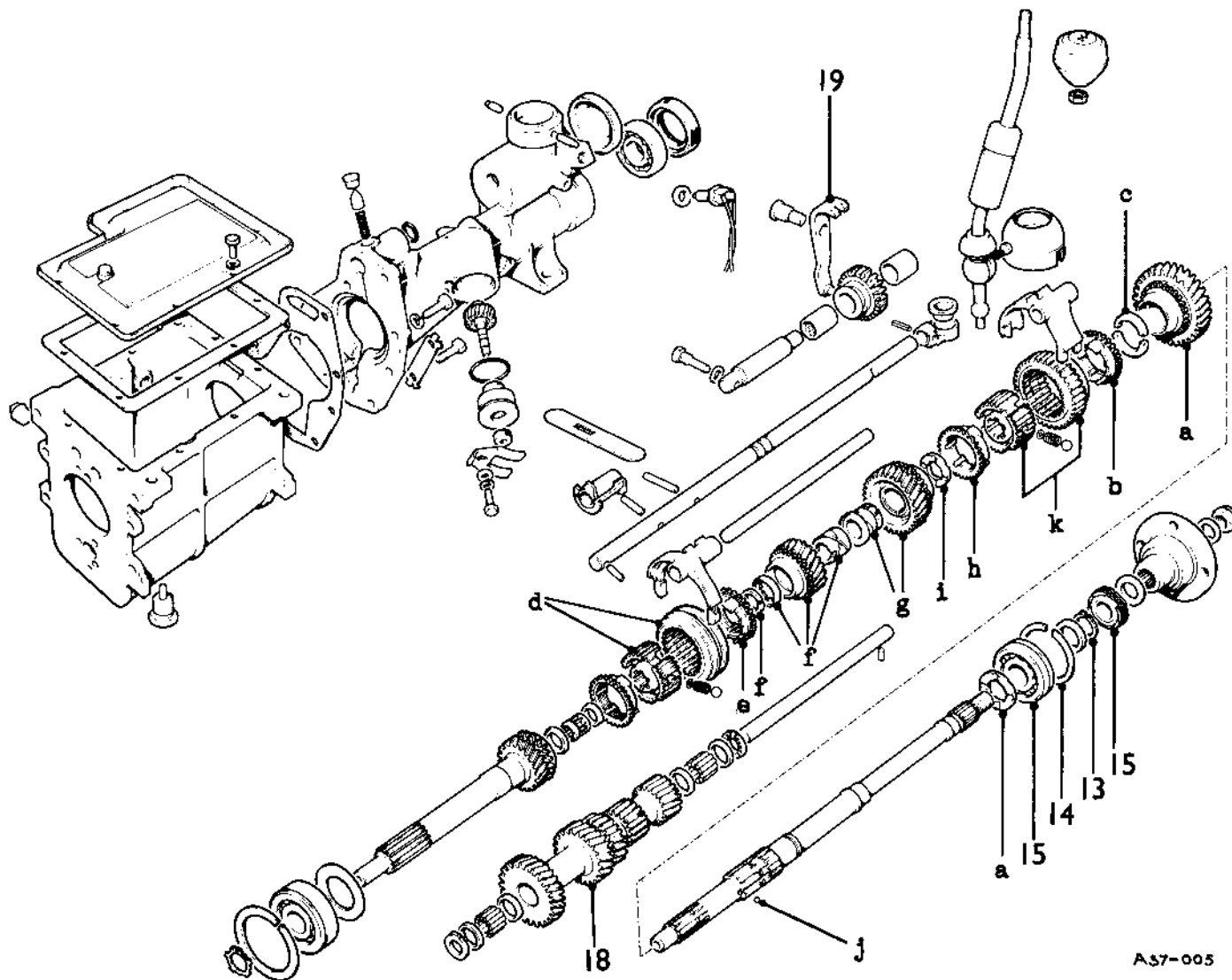

A57-005

- 21 Scribe the sleeve and synchro-hub assemblies of 1st/2nd and 3rd/4th speeds to ensure reassembly in the original locations. Separate the sleeves from the hubs ensuring that care is taken to capture the three balls and springs in each assembly.  
Note: In some instances shims may be fitted below the springs.
- 22 Remove the 25 needle rollers from each end of the laygear cluster.
- 23 Remove the needle roller retaining rings from the laygear (only if renewal is intended).
- 24 Press out the bush from the reverse/idler gear.
- 25 Remove the reverse operating lever pivot pin from the gear case (only if renewal is intended).

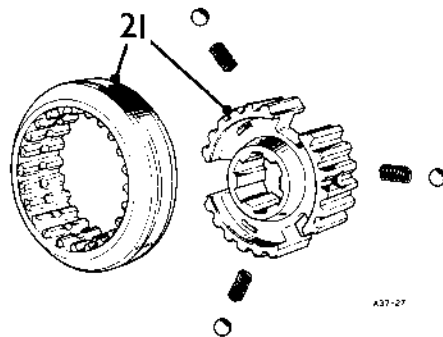

**Preparation for reassembly**

- 26 Thoroughly clean and examine all components. Obtain new parts as necessary. Renew all gaskets and seals.
- 27 If required fit new needle roller retaining rings to the laygear to the dimensions shown. Care must be taken not to damage the laygear bore.
- 28 Using grease install the needle rollers (25 each side) in the laygear. Fit dummy layshaft, tool 18G 1208.
- 29 Fit the shims (if removed), springs and balls to the 1st/2nd speed synchro-hub and slide the sleeve into position observing the scribe marks made prior to dismantling. The teeth of the outer member must be fitted adjacent to the larger boss of the synchro-hub.
- 30 Check the load required to shift the sleeve in either direction. This should be within 19-27 lb (8.7-12.2 kg). Add or remove shims to obtain required effort.
- 31 Fit the shims (if removed), springs and balls to the 3rd/4th speed synchro-hub and slide the sleeve into position observing the scribe marks made prior to dismantling.
- 32 Check the load required to shift the sleeve in either direction. This should be within 19-21 lb (8.7-9.5 kg). Add or remove shims to obtain required effort.

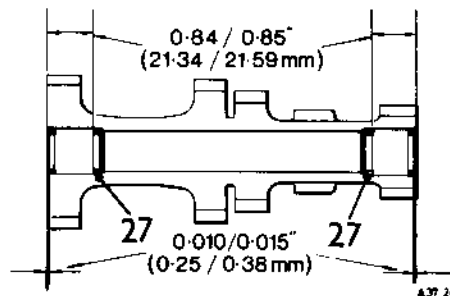

- 33 Fit a new brush to the reverse/idler gear. The bush should be flush with the boss opposite the collar of the operating lever. Ream the bush within 0.6585-0.6592 in diameter (16.7279-16.8011 mm).

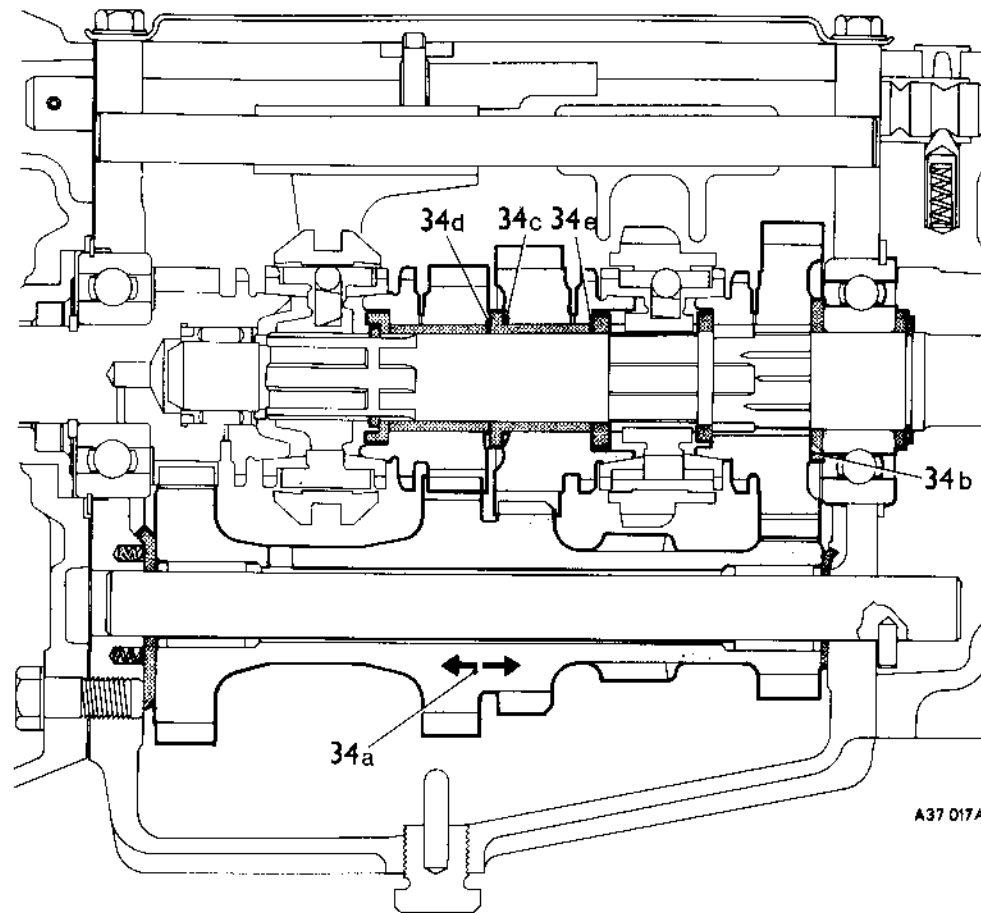

- 34 Check that the following requirements obtain:
  - a Laycluster end-float - 0.007-0.015 in (0.178-0.381 mm).
  - b 1st gear end-float (between split collars and thrust washer) - 0.004-0.013 in (0.102-0.33 mm).
  - c 2nd gear end-float (on bush) 0.002 in (0.051 mm).
  - d 3rd gear end-float (on bush) 0.002-0.006 in (0.051-0.152 mm).
  - e Mainshaft bushes (2nd and 3rd gears) - 0-0.006 in (0-0.051 mm). Adjust clearances by means of selective washer. Four alternative washers are available in 0.003 in (0.076 mm) steps.
- 35 Renew the first motion shaft bearing, see 37.20.17.

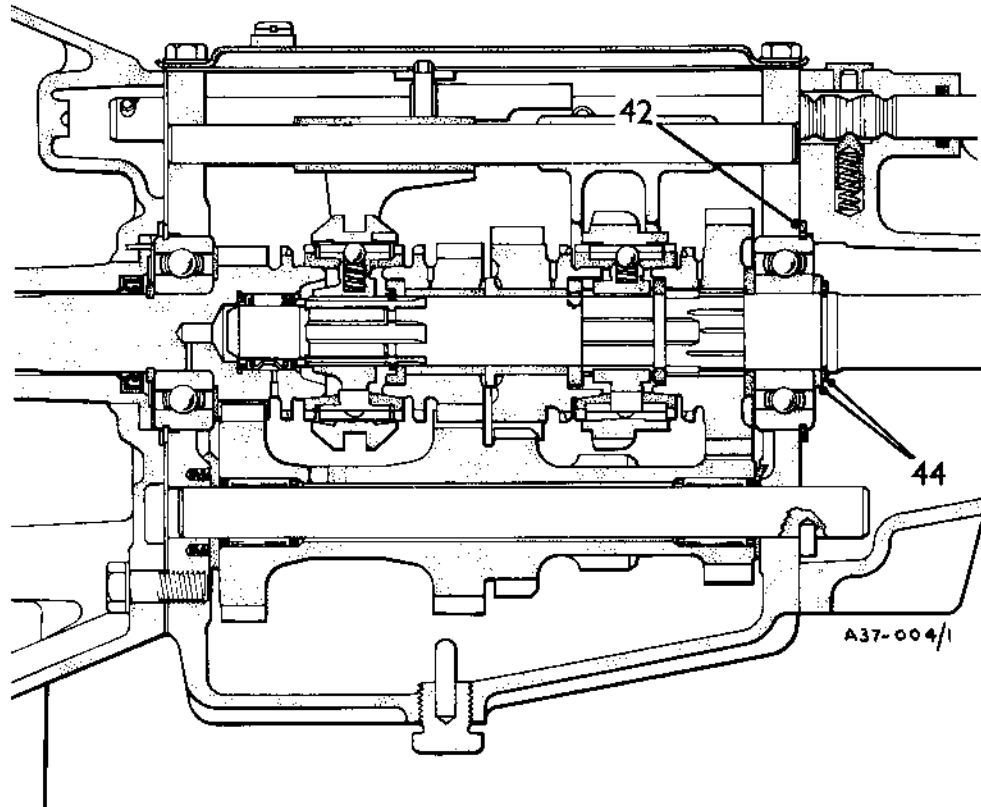

### Reassembling

- 36 Locate the laygear front and rear thrust washers in position ensuring that their respective tabs engage in the casing slots.
- 37 Place the laygear cluster complete with dummy shaft in the bottom of the gear case. (Large gear to front of case.)
- 38 Fit the following components to the mainshaft.
  - a 1st/2nd speed synchro assembly (larger hub boss to front of gearcase).
  - b 2nd speed synchro-cup.
  - c Locating ball for selective washer.

- d Selective washer, ensuring groove on washer inner diameter aligns with ball.
- e 2nd gear and bush (bush collar to front of gearbox), 3rd gear and bush, and thrust washer (rim of washer to front of gearbox).
- f Using tool 18G 1198 fit the retaining circlip ensuring that the inclined end of the clip faces forward and the clip end aligns with the edge of the mainshaft spline.
- g 3rd gear synchro-cup, 3rd gear synchro assembly (larger boss to hub of front of gearbox).
- h 1st speed synchro-cup, split collars, 1st gear and thrust washer.

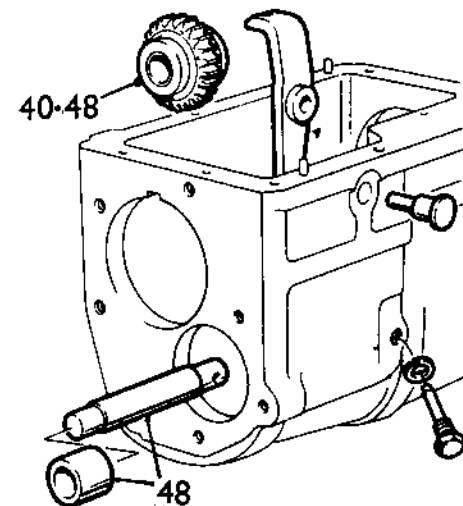
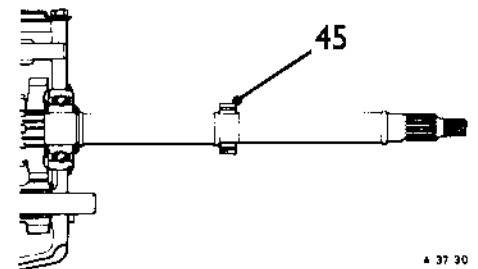
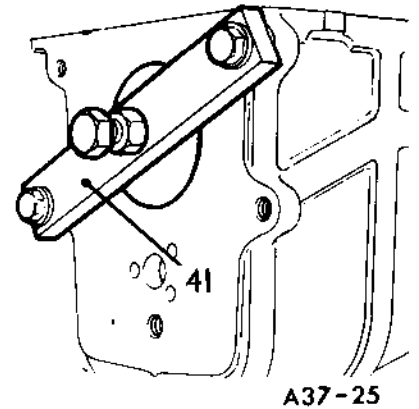
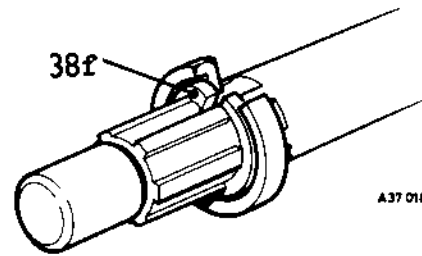

- 39 Tilt the mainshaft (rear end leading) into position through the top cover aperture.
- 40 Place the reverse gear in the bottom of the gear case and fit the reverse operating lever.
- 41 Fit the steady bracket of 18G 47 BP to the front of the gear case engaging the mainshaft spigot.
- 42 Fit the snap ring to the mainshaft centre bearing and slide the bearing (snap ring trailing) on to the mainshaft.
- 43 Drive the bearing into position using tool 18G 1197 and the bearing replacer of 18G 47 BP.
- 44 Fit the selective washer and circlip. Four selective washers are available in 0.003 in (0.076 mm) steps. Mainshaft end-float should not exceed 0.002 in (0.051 mm).
- 45 Fit the speedometer gear.
- 46 Remove the steady bracket of 18G 47 BP from the front of the gear case and fit spigot bearing and rings, 4th speed synchro-cup, and the 1st motion shaft.
- 47 Fit the layshaft, removing the dummy shaft in the process.
- 48 Fit the reverse gear, reverse gear shaft and spacer.

continued

- 49 Fit the selector forks and shaft.
- 50 Fit the gear selector mechanism, see 37.16.37.
- 51 Fit the rear extension and drive flange, see 37.12.01.
- 52 Fit the three thrust springs to the laygear front bearing.
- 53 Fit the clutch housing gasket, clutch housing, clutch release fork and bearing, see 37.12.07. Ensure splines of 1st motion shaft do not damage seal.
- 54 Fit the gear case drain plug and fill to level plug with fresh oil.
- 55 Fit the spool interlock plate, gasket and top cover.

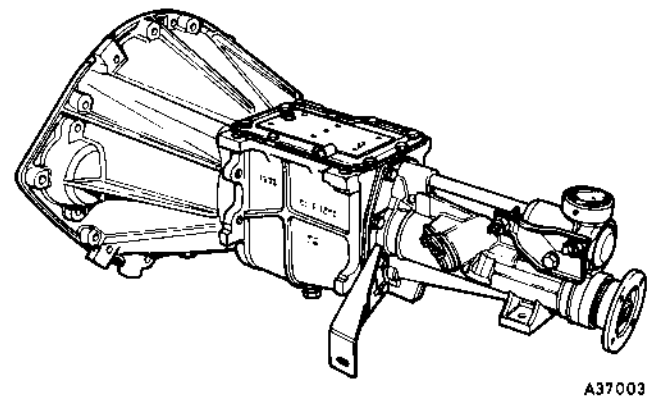
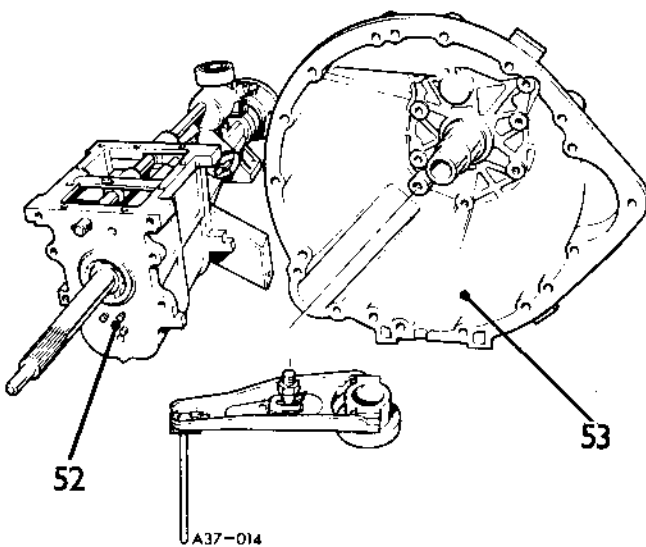
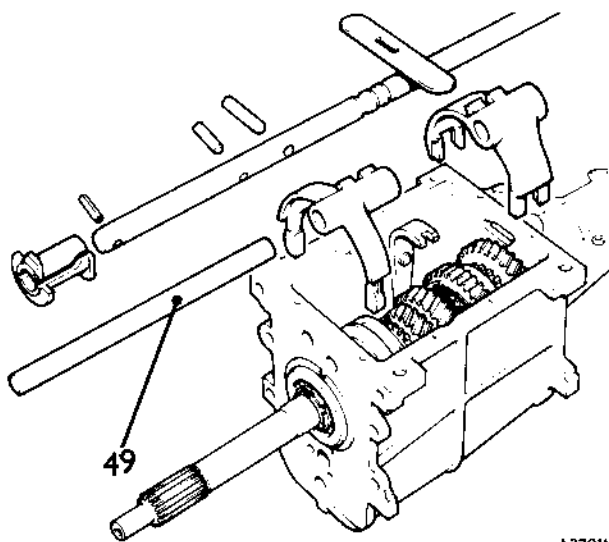
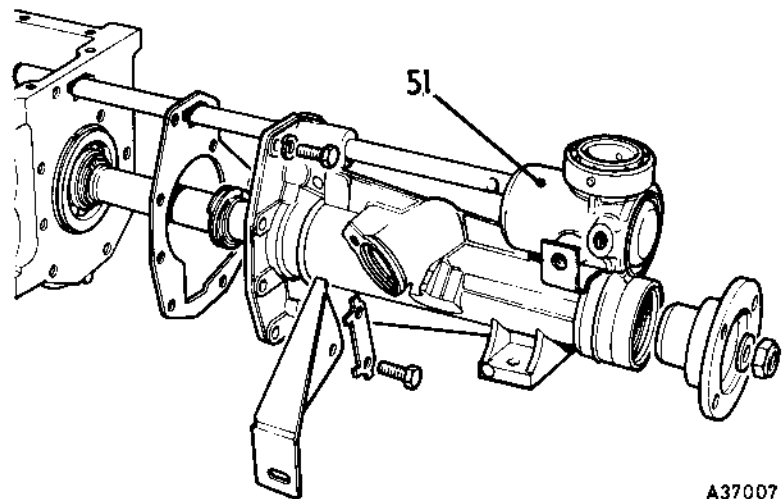
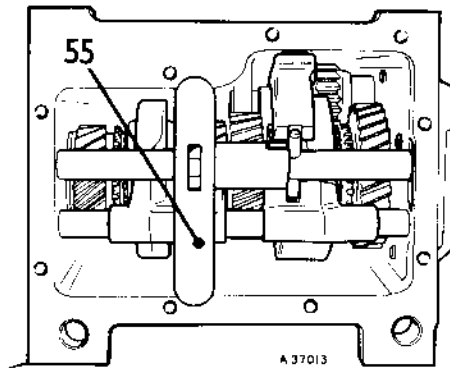



## SYNCHRONISER ASSEMBLIES

**Remove and refit** 37.20.07

Service tools: Refer operation 37.20.04

### Removing

Instructions 1 to 17 and 20a to 20h.

### Refitting

Instructions 38 to 40, 42 to 50 and 52 to 55.

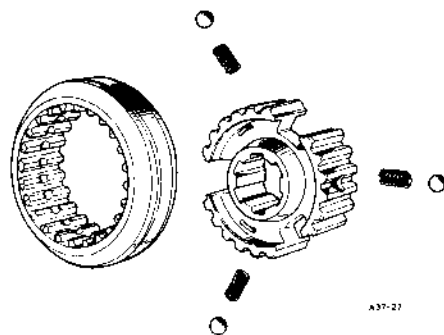

## FIRST MOTION SHAFT

**Remove and refit** 37.20.16

Service tools: 18G 1208, 3072 or S4235 A, S4235 A - 2

### Removing

- 1 Remove the gearbox from the car, see 37.20.01.
- 2 Remove the rear extension, see 37.12.01.
- 3 Remove the clutch housing, see 37.12.07.
- 4 Insert tool 18G 1208 and push out the layshaft.
- 5 Allow the laygear with tool 18G 1208 to drop to the bottom of the gearbox case.
- 6 Fit tool 3072 and adaptor S4235 A - 2 to the first motion shaft.
- 7 Extract the first motion shaft from the gearbox.
- 8 Remove the spigot bearing and spacers (2).
- 9 Remove the 4th gear synchromesh cup.

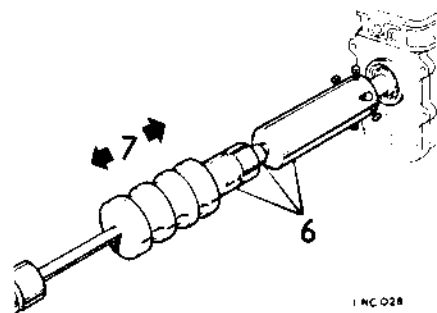
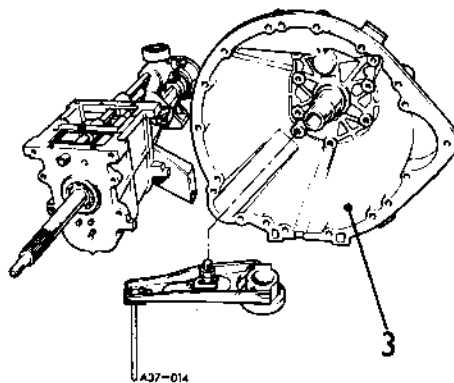

## FIRST MOTION SHAFT BEARING

**Remove and refit** 37.20.17

Service tools 18G 1208, 3072 or S4235 A, S4235-2

### Removing

- 1 Remove the first motion shaft, see 37.20.16.
- 2 Remove the bearing circlip.
- 3 Remove the bearing snap ring.
- 4 Using tool S4235 A and adaptor S4235 A-2 remove the bearing from the shaft.
- 5 Remove the oil flinger.

### Refitting

- 6 Reverse instructions 1 to 5. Use grease to retain the oil flinger when fitting the bearing to the shaft.

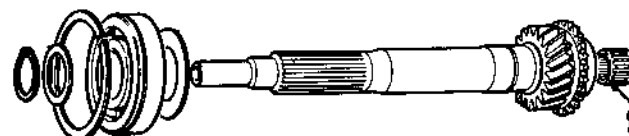
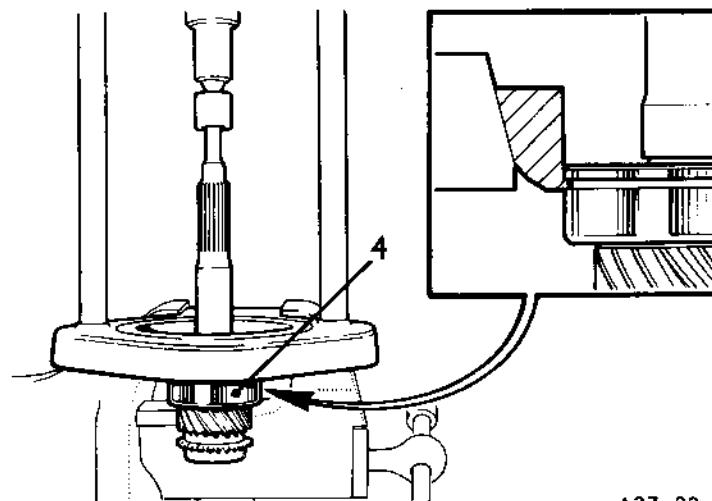
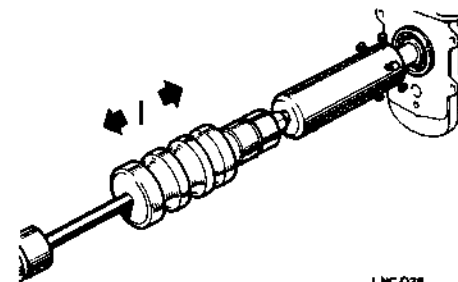

### Refitting

- 10 Reverse instructions 1 to 9.

### LAYSHAFT

**Remove and refit** 37.20.19

Service tools: S337 or 18G 1205, 18G 1208

#### Removing

- 1 Remove the gearbox from the car, see 37.20.01.
- 2 Remove the clutch housing, see 37.12.07.
- 3 Remove the top cover and spool interlock plate.
- 4 Remove the rear extension, see 37.12.01.
- 5 Using tool 18G 1208 displace and remove the layshaft.

#### Refitting

- 6 Reverse instructions 1 to 5.

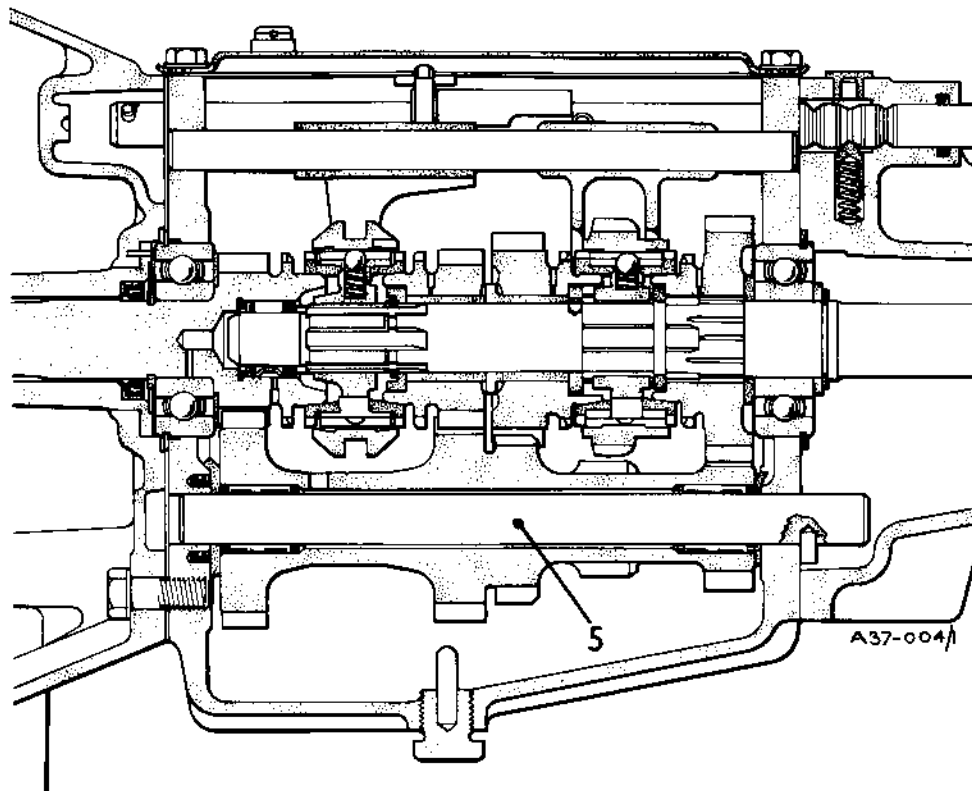

### MAINSHAFT BEARING

**Remove and refit** 37.20.26

Service tools: S337 or 18G 1205, 18G 1208, 18G 1197.

#### Removing

As operation 37.20.04 Instructions 1 to 4 and 6 to 16.

#### Refitting

As operation 37.20.04 Instructions 42 to 48, 50, and 52 to 55.

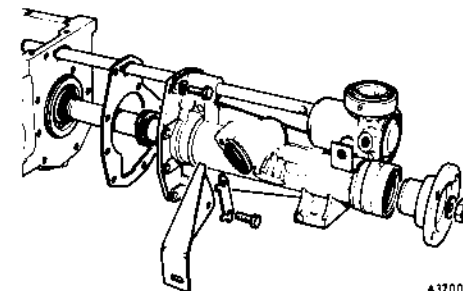

### LAYSHAFT BEARING

**Remove and refit** 37.20.22

Service tools: S337 or 18G 1205, 18G 1208, 18G 1199, S145 C, 18G 1197, 3072 or S4235 A, S4235 A - 2

As operation 37.20.04 instructions 1 to 10, 13 to 18, 22, 23, 27, 28, 36, 37 and 41 to 55.

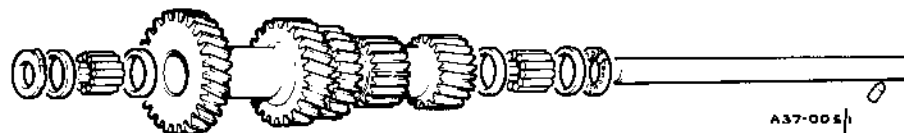

## REAR OIL SEAL

Remove and refit 37.23.01

Service tools: S337 or 18G 1205

### Removing

- 1 Raise the car.
- 2 Remove the drive flange, see 37.10.01.
- 3 Prise out the oil seal.

### Refitting

- 4 Evenly install the new seal in the gearbox rear extension ensuring that it is flush with the rear face of the extension housing. Note that the seal lips must be towards the gearbox.
- 5 Lubricate the seal lips and driving flange seal contact area.
- 6 Fit the drive flange, see 37.10.01.
- 7 Lower the car.

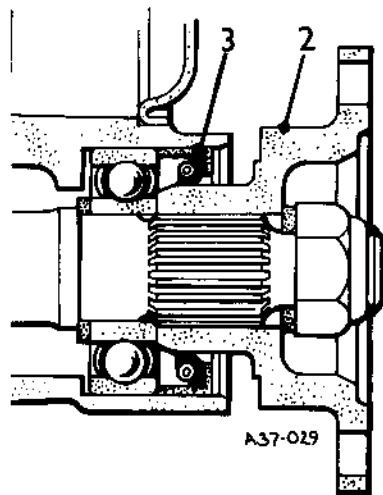

## GEAR CHANGE ROD SEAL

Remove and refit 37.23.10

Service tools: S337 or 18G 1205

As operation 37.16.37.

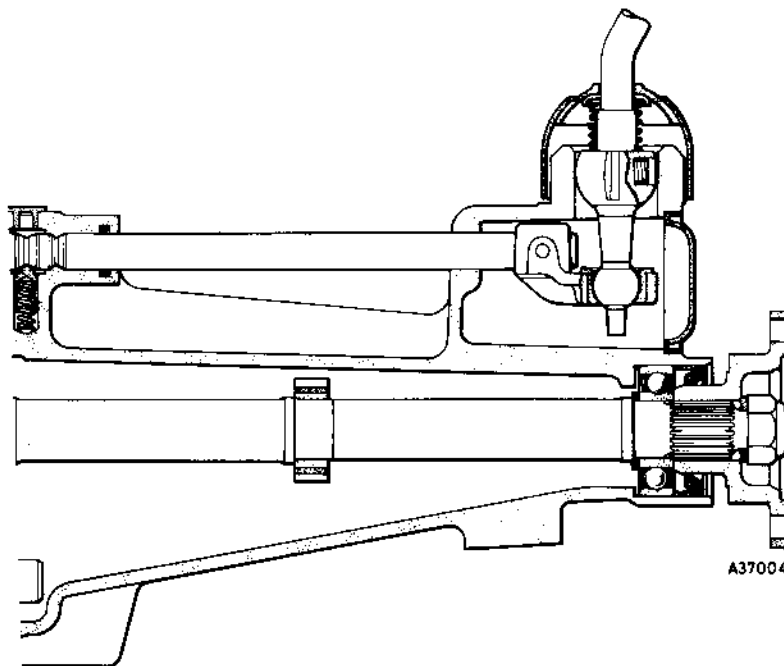

## FIRST MOTION SHAFT OIL SEAL

Remove and refit 37.23.04

### Removing

- 1 Remove the gearbox from the car, see 37.20.01.
- 2 Remove the clutch housing, see 37.12.07.
- 3 Remove the oil seal.

### Refitting

- 4 Evenly install a new oil seal ensuring that the seal lips are towards the clutch.
- 5 Lubricate the seal lips and ensure that the splines of the first motion shaft are protected by tape to prevent damage to the seal lip when the clutch housing is fitted.
- 6 Fit the clutch housing, see 37.12.07.
- 7 Remove the tape from the splines of the first motion shaft.
- 8 Fit the gearbox to the car, see 37.20.01.

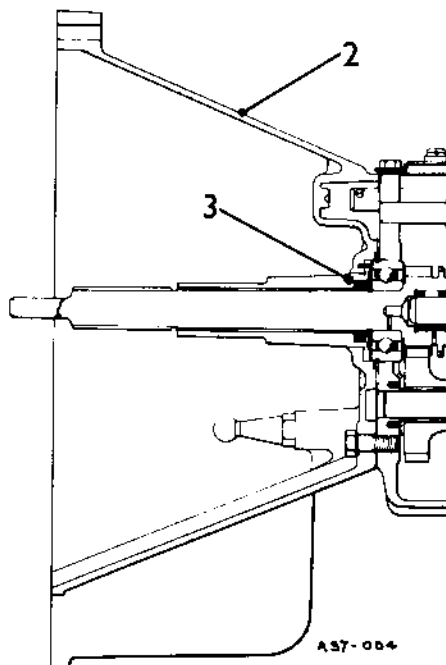



## GEARBOX—5-SPEED

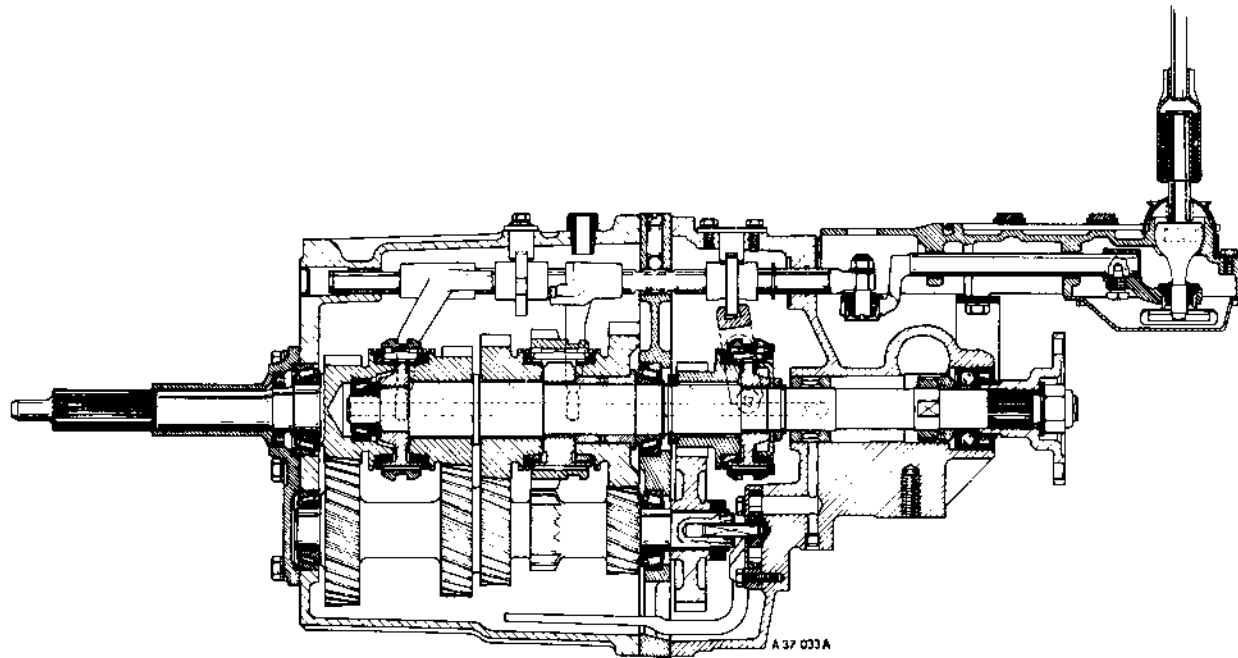

### DRIVE FLANGE

Remove and refit 37.10.01

Service tools: RG 421 or 18G 1205

#### Removing

- 1 Raise the car and support securely.
- 2 Slacken the bolt securing the propeller shaft strap and remove the remaining bolt. Swing the strap clear of the propeller shaft.
- 3 Scribe the relationship of the propeller shaft and gearbox flanges and remove the four securing nuts and bolts.
- 4 Release the propeller shaft from the gearbox flange.

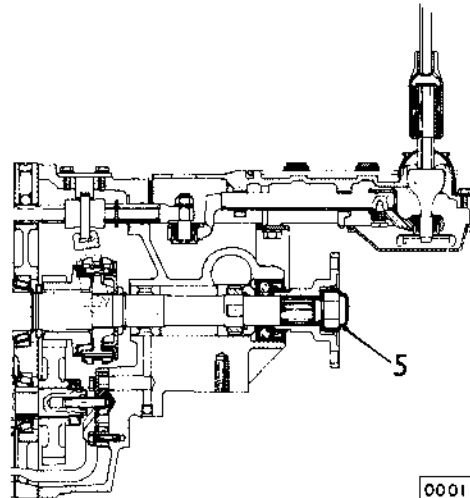

- 5 Using tool RG 421 or 18G 1205 to prevent rotation of the gearbox driving flange remove the securing nut and washer.
- 6 Withdraw the driving flange.

#### Refitting

- 7 Reverse instructions 1 to 6. The gearbox flange nut should be torqued to: 90-120 lbf ft (12.44-16.60 kgf m). Propeller shaft bolts to: 26-34 lbf ft (3.60-4.70 kgf m).

## CLUTCH/BELL HOUSING

Remove and refit 37.12.07

Service tools: ST 1136

#### Removing

- 1 Remove the gearbox from the car, see 37.20.10/55.
- 2 Withdraw the clutch release lever and release bearing, see 33.25.12.
- 3 Remove the six bolts, plain and spring washers securing the clutch housing to the gearcase.
- 4 Remove the clutch housing.

#### Refitting

- 5 Reverse instructions 1 to 4.

## REAR COVER

Remove and refit 37.12.42

Service tools: RG 421 or 18G 1205

#### Removing

- 1 Disconnect the battery.
- 2 Remove the gear lever.
- 3 Raise the car on a ramp or jack and support securely.
- 4 Remove one bolt from the propeller shaft safety strap, slacken the remaining bolt and swing the strap aside.
- 5 Disconnect the propeller shaft from the gearbox.
- 6 Tie the propeller shaft to the vehicle in a position where it allows access to the gearbox.
- 7 Release the rubber rings securing the exhaust system.
- 8 Detach the exhaust system from the manifold down-pipe.
- 9 Remove the gearbox drain plug and drain the oil.
- 10 Disconnect the speedometer cable and remove the speedometer drive pinion and housing, see 37.25.05.
- 11 Using tool RG 421 or 18G 1205 to prevent shaft rotation remove the nut and washer securing the gearbox drive flange.
- 12 Withdraw the drive flange.

continued

- 13 Locate the jack under the engine flywheel and support the weight of engine and gearbox.
- 14 Remove the four bolts, spring washers and plate washers securing the gearbox rear crossmember to the body.
- 15 Carefully lower the jack slightly to facilitate access to the top of the gearbox.
- 16 Remove the nut, washer and pin securing the remote control linkage to the gearbox selector rod and detach the reverse switch lead.
- 17 Remove the two bolts and spring washers securing the flange of the fifth gear spool locating boss.
- 18 Withdraw the fifth gear spool locating boss.

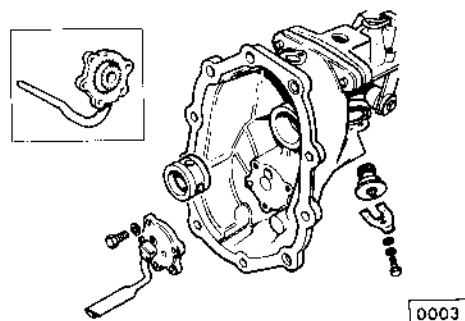

- 24 Remove the rear oil seal, bearing, spacer, ring and speedometer driving gear from the rear cover.

**Refitting**

- 25 Remove the slave bolts from the gearbox centre plate.
- 26 Ensure that the centre plate and rear cover mating faces are clean and fit a new gasket to the centre plate.

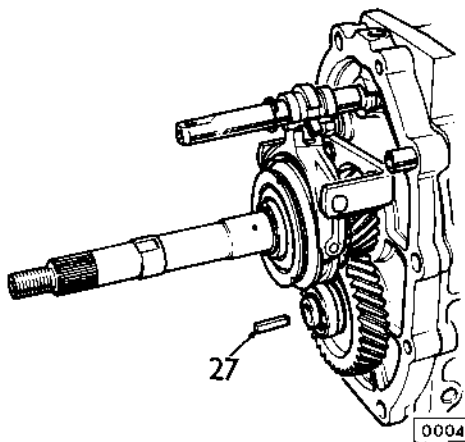

- 27 Engage the oil pump drive shaft in the layshaft.

- 28 Note the radial relationship of the square oil pump drive and align the oil pump gear centre.
- 29 Offer up the rear cover to the gearbox mainshaft and slide carefully into position. Ensure that the oil pump shaft engages the oil pump.
- 30 Fit and tighten the rear cover securing bolts.

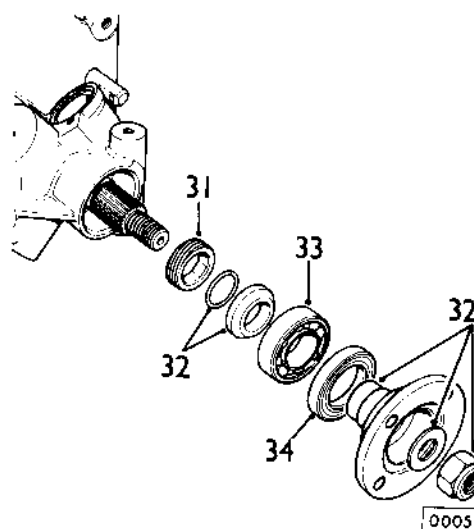

- 31 Fit the speedometer driving gear ensuring that it properly engages the flats on the mainshaft and that the tapered head of the gears is to the rear.
- 32 Fit the circlip and the spacer, (machined recess in spacer towards the circlip).
- 33 Fit the rear bearing.
- 34 Fit a new oilseal. Lubricate the seal lip.
- 35 Lubricate the seal contact area on the driving flange and fit the flange, washer and nut.
- 36 Fit the 5th gear spool locating boss.
- 37 Fit the pin, washer and nut securing the remote control linkage to the gearbox selector rod. Connect the reverse switch lead.
- 38 Raise the jack supporting the engine and bolt the gearbox crossmember to the body.

- 39 Remove the engine jack.
- 40 Connect the propeller shaft to the gearbox.
- 41 Fit the propeller shaft safety strap.
- 42 Connect up the exhaust system.
- 43 Fit and tighten the gearbox drain plug.
- 44 Refill the gearbox with fresh oil.
- 45 Lower the car.
- 46 Fit the gear lever.
- 47 Connect the battery.

**OIL PUMP**

Remove and refit 37.12.47

**Removing**

- 1 Remove the rear cover, see 37.12.42.
- 2 Remove the four bolts and spring washers securing the oil pump cover to the gearbox rear cover.
- 3 Withdraw the oil pump cover and oil intake pipe.
- 4 Remove the internal and external toothed gears.

**Refitting**

- 5 Reverse instructions 1 to 4.

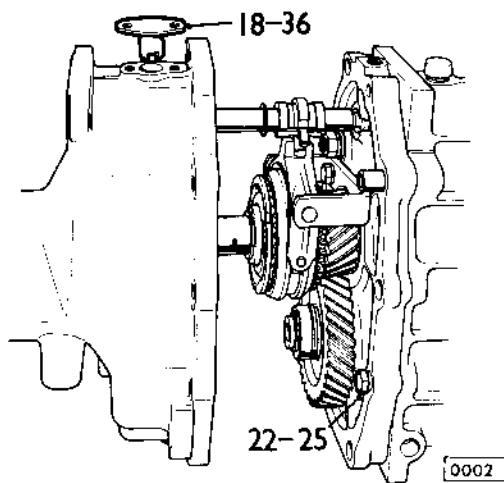
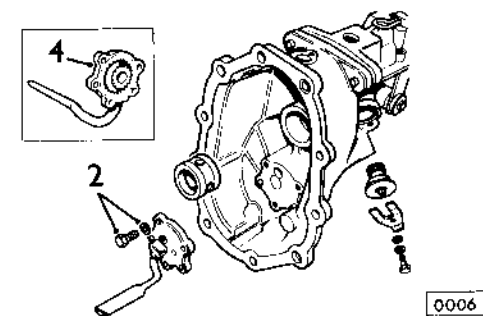

- 19 Place a container under the gearbox centre plate/rear cover to catch residual oil when the rear cover is disturbed.
- 20 Remove the bolts and spring washers securing the rear cover to the gearbox.
- 21 Withdraw the rear cover and gasket ensuring that the centre plate is not disturbed.
- 22 Fit temporary slave bolts to retain the centre plate in position.
- 23 Remove the oil pump drive shaft.

## OIL PUMP

Test 37.12.50

- 1 Ensure that the gearbox oil level is correct.
- 2 Start the engine and allow to idle.
- 3 Remove the threaded plug in the rear cover, a steady flow of oil should be expelled.
- 4 Switch off the engine.
- 5 Prime the plug with 'Locquic Primer Grade T' then applying 'Loctite 270' immediately prior to assembly, refit the threaded plug.
- 6 Check and top up the gearbox level.

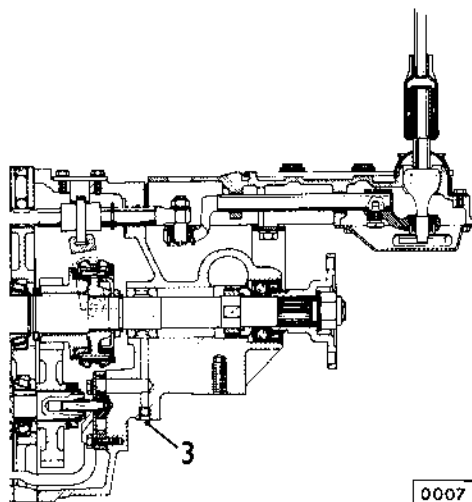

## GEAR CHANGE LEVER

Remove and refit 37.16.04

### Removing

- 1 Select neutral and unscrew and remove the gear lever knob.
- 2 Slacken the two screws securing the gear lever gaiter and top panel assembly to the rear of the console.
- 3 Remove the gear lever gaiter and panel assembly.
- 4 Remove the four screws retaining the gear lever draught excluder and flange assembly.
- 5 Withdraw the draught excluder and flange assembly.
- 6 Remove the dome cover securing the gear lever to the correct extension housing.
- 7 Remove the countersunk screw and bolt securing the bias spring rear bridge, and withdraw the bridge and liner.
- 8 Carefully prise the bias spring legs clear of the gear lever pins.
- 9 Gently lift out the gear lever taking care not to lose the nylon plunger and spring (anti-rattle) from the gear lever pivot ball.

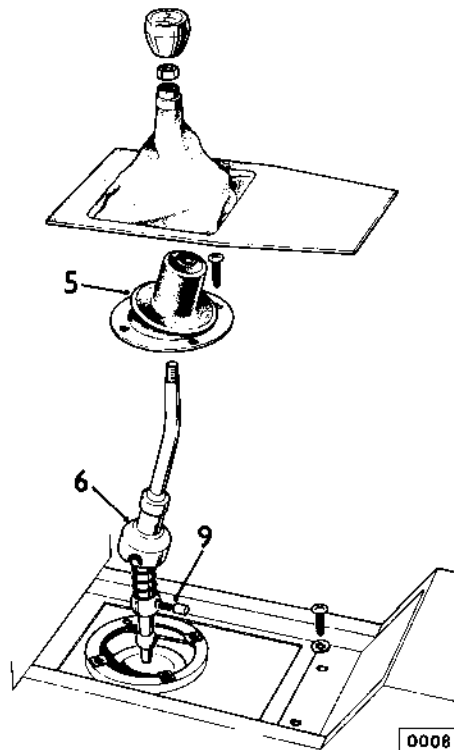

### Refitting

- 10 Reverse instructions 1 to 9.

## GEAR CHANGE REMOTE CONTROL ASSEMBLY

Remove and refit 37.16.19

### Removing

- 1 Disconnect the battery.
- 2 Remove the gear lever, see 37.16.04/55.
- 3 Raise the car on a ramp, or jack up the rear of the vehicle and support securely.
- 4 Remove one bolt from the propeller shaft safety strap and slacken the remaining bolt and swing the strap aside.
- 5 Disconnect the propeller shaft from the gearbox.
- 6 Tie the propeller shaft to the vehicle in a position where it allows access to the gearbox.
- 7 Release the rubber rings securing the exhaust system.
- 8 Detach the exhaust system from the manifold down pipe.

- 9 Locate a jack under the gearbox and support weight.
- 10 Disconnect the two reverse light switch leads.
- 11 Disconnect the speedometer cable at the gearbox.
- 12 Remove the four bolts securing the gearbox rear mounting bracket.
- 13 Carefully lower the jack and gearbox sufficient to obtain access to the remote control assembly.
- 14 Disconnect the nut, washer and pin securing the gearbox selector shaft to the remote control shaft.
- 15 Remove the four bolts, spring and plain washers securing the remote control assembly to the gearbox rear cover.
- 16 Withdraw the remote control assembly.

### Refitting

- 17 Reverse instructions 1 to 16.

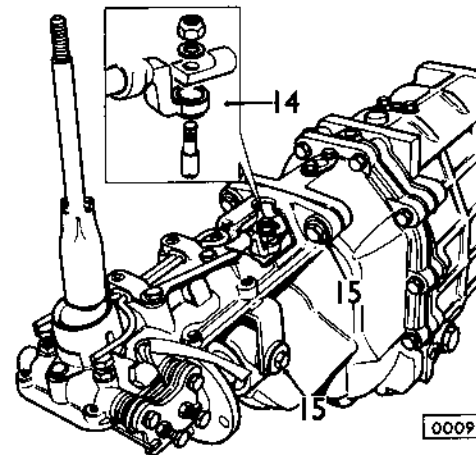

## GEAR CHANGE REMOTE CONTROL ASSEMBLY

Overhaul

37.16.20

### Dismantling

- 1 Remove the remote control assembly from the gearbox.

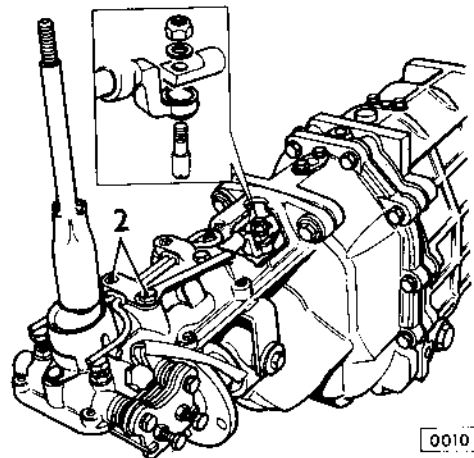

0010

- 2 Remove the two bolts and two countersunk screws securing the bias spring bridge plates.
- 3 Remove the two bridge plates, bridge plate liners and the bias spring.
- 4 Remove the bias spring adjusting bolts and locknuts.
- 5 Remove the two bolts and washers securing the reverse baulk plate assembly and withdraw the reverse baulk plate, springs and spacers.
- 6 Remove the four bolts and washers securing the bottom cover plate.
- 7 Remove the bottom cover plate.
- 8 Remove the reverse light switch and locknut.
- 9 Remove the square-headed pinchbolt securing the selector shaft elbow.
- 10 Remove the selector shaft elbow.
- 11 Withdraw the selector shaft.
- 12 Press out the two selector shaft bushes in the remote control casing.
- 13 Remove the circlips securing the pivot ball and bushes in the selector shaft elbows and press out the bushes and pivot balls.

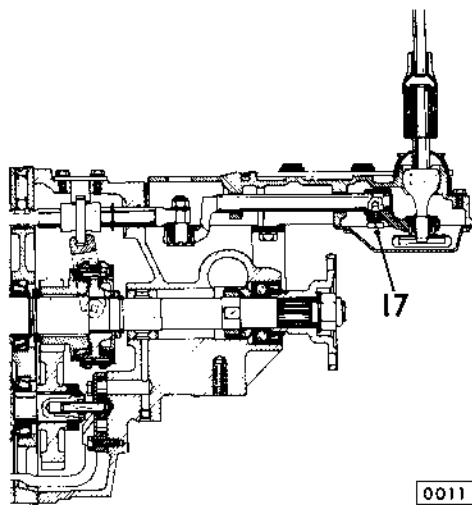

0011

### Assembling

- 14 Press in new selector shaft bushes in the remote control casing.
  - 15 Fit new bushes, pivot balls and circlips to the selector shaft elbow.
  - 16 Fit the selector shaft to the casing.
  - 17 Fit the rear elbow and secure with the square-headed pinchbolt.
  - 18 Fit the baulk plate assembly.
  - 19 Fit the reverse switch and locknut.
  - 20 Fit the bottom cover plate.
  - 21 Fit the bias spring adjusting bolts and locknuts.
  - 22 Fit the bias spring, bridge plate liners and bridge plates.
  - 23 Fit the remote control assembly to the gearbox.
- Operations to be carried out following the fitting of the remote control assembly to the gearbox.
- 24 Fit the gear lever.

### Adjusting the reverse baulk plate

Adjustment of the reverse baulk plate must be carried out on a complete gearbox assembly.

- 25 Remove the bottom cover plate of the gear lever remote control assembly.
- 26 Locate the gear lever in neutral in a vertical position.
- 27 Slacken the baulk plate adjusting bolts and locknuts until the baulk plate is in contact with the backing plate.

- 28 Tighten the adjusting bolts *equally* until they just start to move the baulk plate out of contact with the backing plate.
- 29 Using a straight edge and feeler gauge move the adjusting bolts *equally* until a clearance of 0.050 to 0.060 in (1,27 to 1,42 mm) exists between (a) the lower face of the gear lever and the underside of the baulk plate. Tighten the locknuts. Note also that (b) a minimum clearance of 0.10 in (0,254 mm) must exist between the upper face of the baulk plate and the lower edge of the gear lever bush.

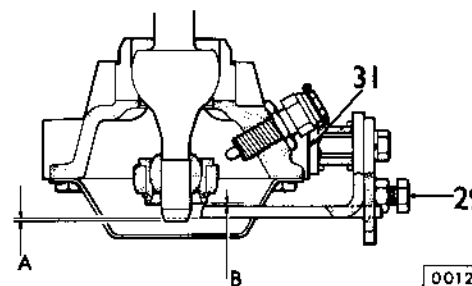

0012

### Adjustment of 1st/2nd gate stop

This operation must be carried out following the adjustment of the reverse baulk plate.

- 30 Engage 1st plate.
- 31 Check the clearance between the side of the gear lever and the edge of the baulk plate. This should be 0.004 to 0.012 in (0,10 to 0,30 mm). Adjust by adding or removing shims as necessary.
- 32 Check clearance between baulk plate edge and gear lever with 1st and 2nd gears engaged.
- 33 Fit bottom cover plate.

- ### Adjustment of gear lever bias spring
- 34 Unit completely assembled, engage 3rd gear.
  - 35 Adjust the screws to position both legs of spring 0.5 mm clear of lever crosspin.
  - 36 Apply a light load to gear lever in LH direction taking up play. Adjust RH screw downward until RH spring leg just makes contact with crosspin.
  - 37 Repeat instruction 36 on the other side. Play will still be present but at extremes of gear lever travel the crosspin should make contact with the spring legs.
  - 38 Return lever to neutral and rock across gate several times. Lever should return to 3rd/4th gate.
  - 39 Tighten the locknuts.
  - 40 Adjust the reverse switch, see 86.65.20.

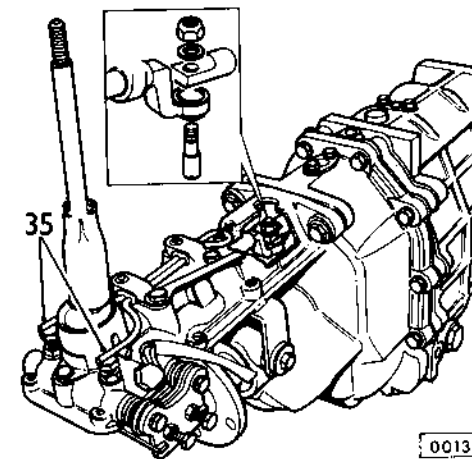

0013



## GEARBOX

### Remove and refit

37.20.01

#### Removing

- 1 Disconnect the battery.
- 2 Remove the gear lever, see 37.16.04.
- 3 Raise the car on a ramp, or jack up and support securely.
- 4 Remove the propeller shaft safety strap.
- 5 Disconnect the propeller shaft at the gearbox flange and tie the propeller shaft so that it will not obstruct gearbox withdrawal.
- 6 Disconnect the electrical connections at the reverse switch.
- 7 Release the speedometer cable at the gearbox.
- 8 Remove the exhaust down pipe.
- 9 Withdraw the starter motor heat shield. ( Spring clips to solenoid.)
- 10 Position a jack under the engine sump and support the engine. To avoid damage to the sump a suitable piece of wood should be interposed between the jack pad and the sump.
- 11 Remove the two bolts securing the clutch slave cylinder to the clutch housing and withdraw the slave cylinder. Do not allow the weight of the cylinder to hang suspended on the fluid hose.
- 12 Remove the two bolts securing the engine sump stiffening plate to the clutch housing.
- 13 Remove the four nuts securing the gearbox rear crossmember to the body.
- 14 Lower the jack located under the engine sump ensuring that radiator hoses are not strained. Ensure also that the gear lever remote control housing does not foul the brake pipe.
- 15 Disconnect the wires to the starter motor and remove the starter motor.
- 16 Remove the bolts and nuts securing the clutch housing to the engine. Note the location of the dowel bolt adjacent to the lower bolt of the clutch slave cylinder mounting flange and the positions of the clips for the electrical harness.

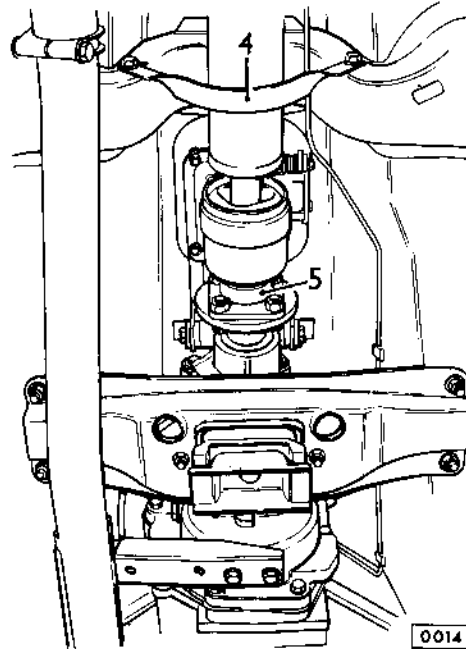

0014

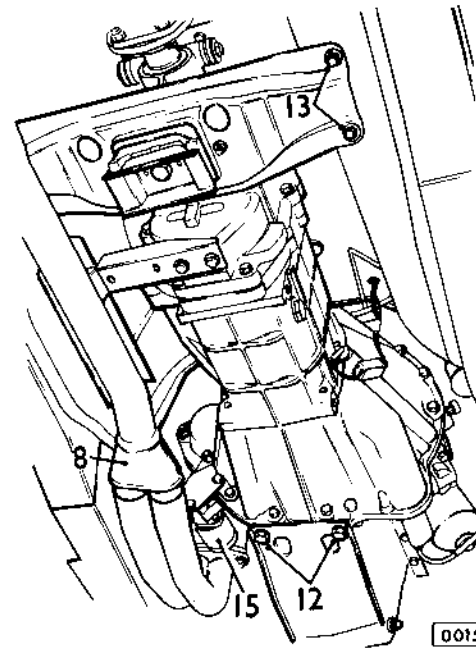

0015

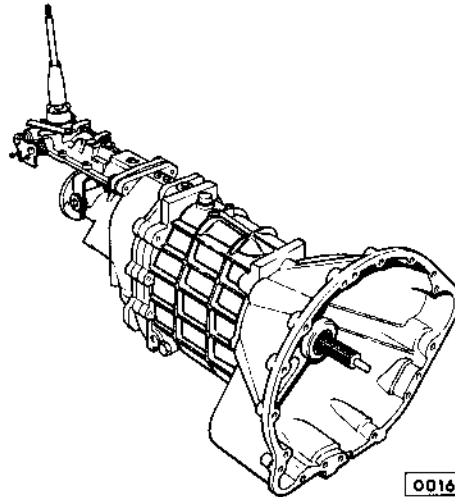

0016

- 17 Carefully withdraw the gearbox and clutch housing assembly ensuring that weight and stress are not imparted to the clutch driving plate. Mention of the fact that the dry weight of the gearbox and clutch housing assembly is approximately 60.5 lb (27.5 kg) provides some idea of the effort required to handle this unit.

#### Refitting

- 18 Reverse instructions 1 to 17.

**GEARBOX ASSEMBLY**

Overhaul 37.20.04

Service tools: 47, 284, 18G 705-1, RG 421 or 18G 1205, RTR 47-23, LC 370-2, 18G 705 or S323, 18G 284 AAH, ST 1136

**Dismantling**

- 1 Place the gearbox on a bench or a gearbox stand ensuring that the oil is first drained.

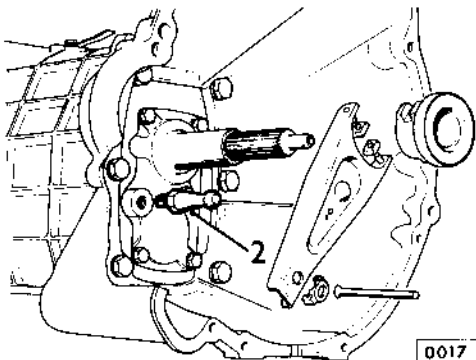

- 2 Using tool ST 1136 unscrew the clutch release lever pivot bolt and withdraw the clutch release lever complete with pivot bolt and release bearing slippers.
- 3 Detach the release bearing and slippers.
- 4 Remove the six bolts, plain and spring washers securing the bell housing to the gearcase and remove the bell housing.
- 5 Remove the nut and connecting pin linking the selector shaft to the remote control shaft.
- 6 Remove the four bolts, spring and plain washers (2 top, 1 either side) securing the remote control housing to the gearcase rear cover.
- 7 Remove the nut and plain washer securing the drive flange to the mainshaft. Use tool RG 421 or 18G 1205 to prevent shaft rotation.
- 8 Withdraw the driving flange.

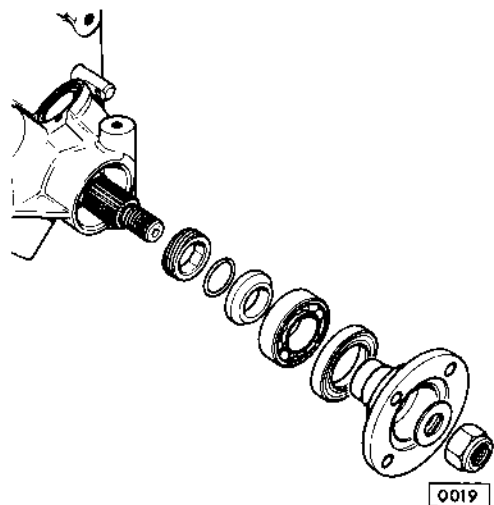

- 9 Remove the speedometer driven gear and housing.
- 10 Remove the two bolts and spring washers securing the locating boss for the selector rear spool and withdraw the locating boss.
- 11 Remove the ten bolts, spring and plain washers securing the rear cover to the gearcase and withdraw the rear cover and gasket.

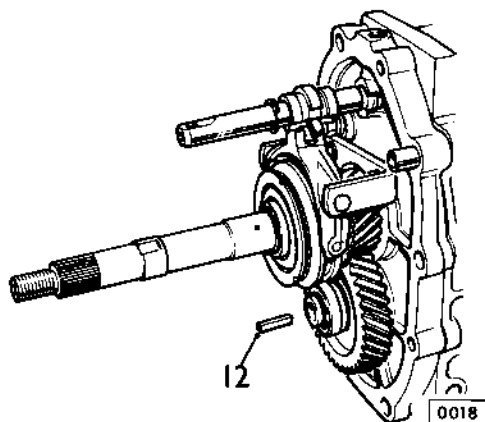

- 12 Withdraw the oil pump drive shaft.
- 13 Remove the fifth gear selector fork and bracket (two bolts and spring washers).

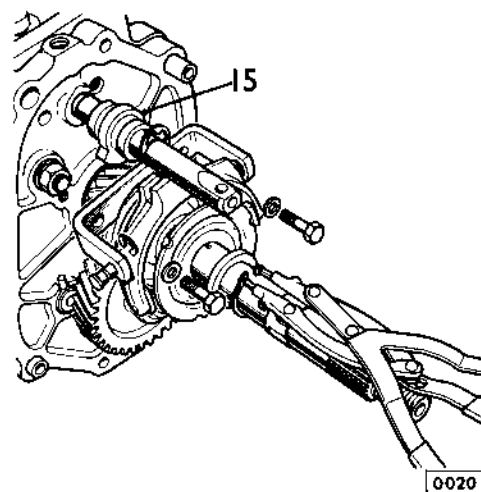

- 14 Remove the circlip from the selector shaft.
- 15 Withdraw the fifth gear selector spool. Note that the longer cam of the spool is fitted towards the bottom of the gearbox.
- 16 Remove the circlip retaining the fifth gear synchro assembly to the mainshaft.

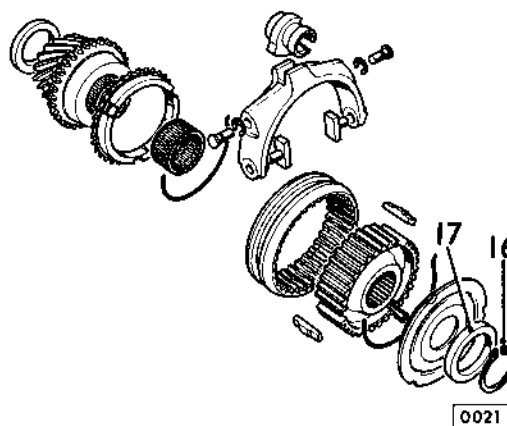

- 17 Withdraw the synchro assembly, fifth gear (driven) and spacer from the mainshaft.

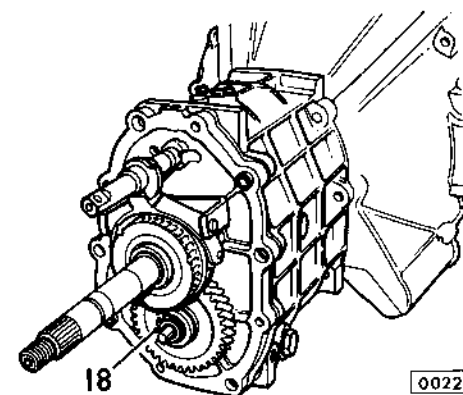

- 18 Remove the circlip retaining the fifth gear (driving) from the layshaft.
- 19 Using tool 18G 705 and adaptors 18G 705-1 remove the fifth gear and spacer from the layshaft.

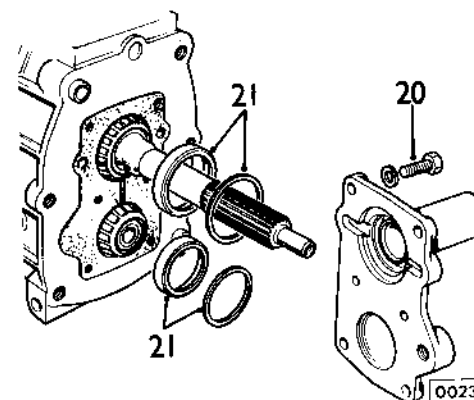

- 20 Remove the front cover and gasket (six bolts and spring washers).
- 21 Remove the input shaft selective washer, bearing track, layshaft selective washer and bearing track from the gearcase.
- 22 Remove the two bolts and spring washers securing the locating boss for the selector shaft front spool and withdraw the locating boss.
- 23 Remove the selector plug, spring and ball from centre plate.

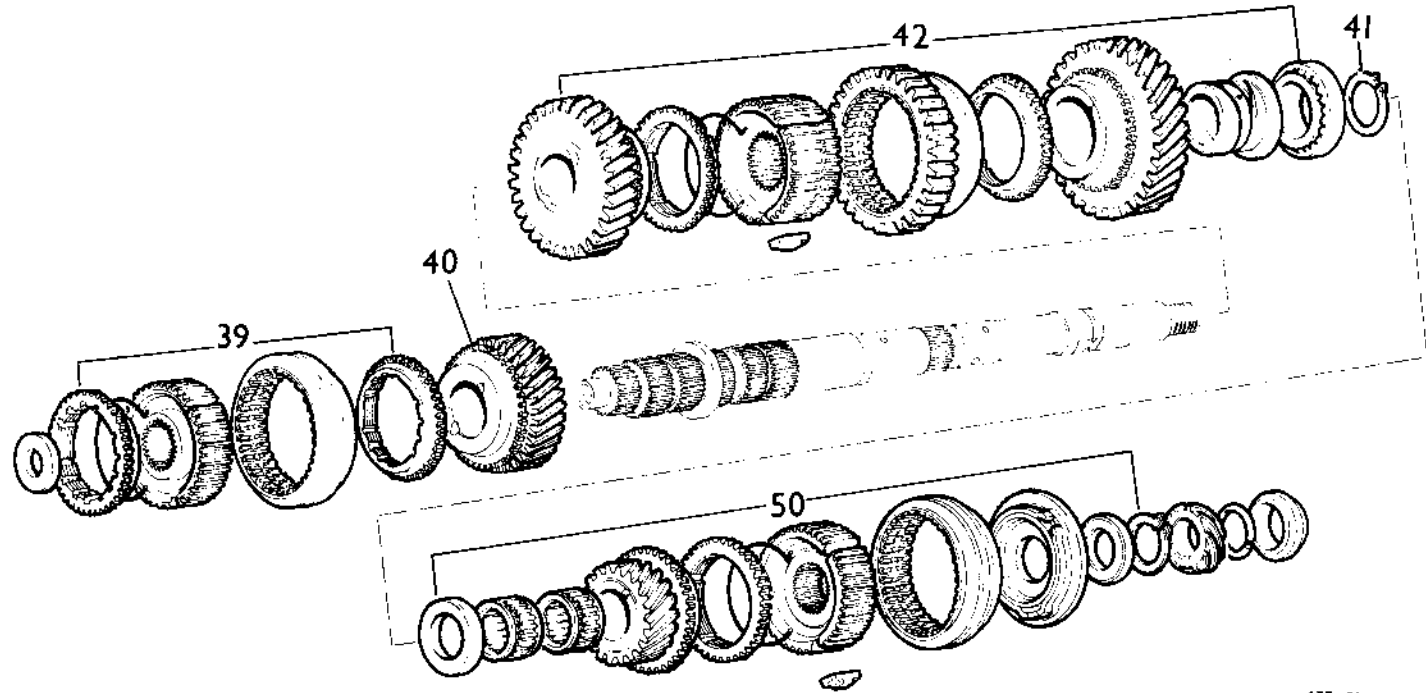
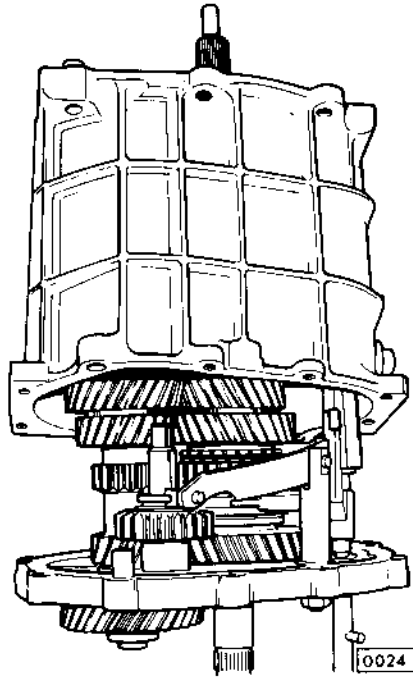

- 24 Supporting the gearbox on the centre plate withdraw the gearcase.
- 25 Remove the input shaft and 1st gear synchro cone.
- 26 Withdraw the layshaft cluster.

- 29 Remove the reverse lever and slipper pad.
- 30 Slide the reverse shaft rearwards and withdraw the reverse gear spacer, mainshaft, selector shaft, selector shaft fork and spool in a forward direction clear of the centre plate.
- 31 Withdraw the selector fork and spool. Note that the shorter cam of the spool is fitted towards the bottom of the gearbox.
- 32 Remove the nut and spring washers securing the reverse gear pivot shaft and remove the pivot shaft (only if renewal of the pivot shaft and/or the centre plate is intended).
- 33 Remove the centre plate from the vice and extract the two dowels (only if dowels and/or centre plate renewal is intended).

**Input Shaft and Front Cover**

- 34 Using tool RTR 47-23 remove the external bearing.

- 35 Using tools 18G 284 AAH and 284 withdraw the internal bearing track.
- 36 Remove the oil seal from the front cover.

**Layshaft**

- 37 Using tools LC 370-2 remove the layshaft bearings.

**Mainshaft**

- 38 Remove the pilot bearing and spacer.
- 39 Remove the 3rd and 4th speed synchroniser hub and sleeve.
- 40 Remove the 3rd speed gear.
- 41 Remove the circlip securing the mainshaft bearing.
- 42 Remove the bearing, 1st gear and bush, 1st and 2nd speed hub, sleeve and synchromesh cones, and 2nd gear.

**Rear Cover**

- 43 Remove the oil seal, bearing, speedo gear, circlip and sleeve and oil sleeve. Remove the oil pump drive, pump cover and gears.
- 44 Thoroughly clean and examine all components. Obtain new parts as necessary.

*continued*

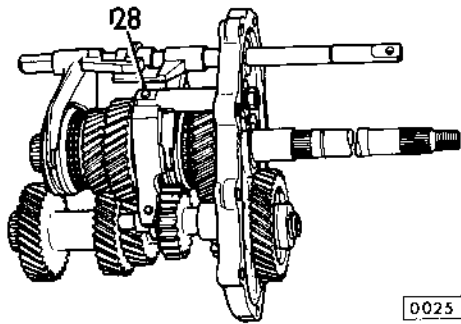

- 27 Support the centre plate complete with gears in protected vice jaws.
- 28 Remove the reverse lever pivot pin circlip and pivot pin.

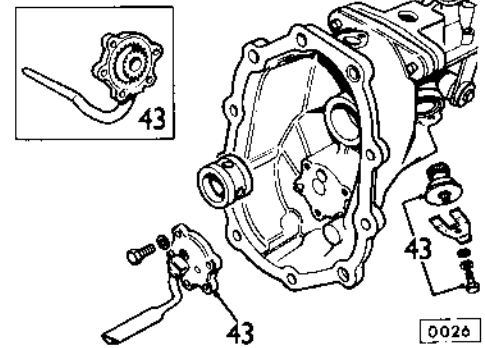

A37-070

**Layshaft**

45 Fit the bearings to the layshaft.

**Mainshaft**

46 *Synchro Assemblies.* With the outer sleeve held, a push-through load applied to the outer face of the synchro hub should register 18 -- 22 lb (18.2 -- 10 kgm) to overcome spring detent in either direction.

47 *Checking 1st speed bush end-float.* Fit 2nd gear, 1st/2nd speed synchro hub and 1st gear bush to the mainshaft.

Manufacture a spacer to the dimensions illustrated and slide the spacer on the mainshaft.

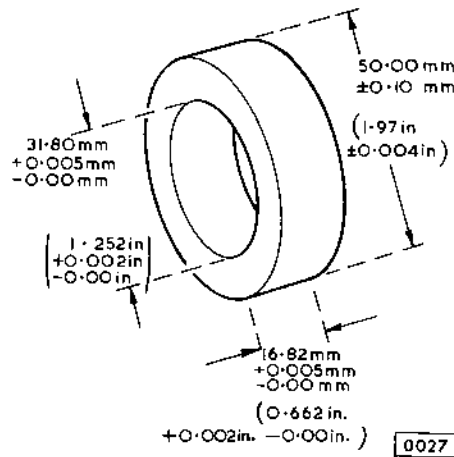

Using an oil circlip and feeler gauges check the clearance existing between the spacer and the circlip, which should be within 0.005 to 0.055 mm (0.0002 to 0.002 in). The first speed bush is available with collars of different thickness. Select a 1st speed bush with a collar which will give the required end-float.

48 Remove the circlip, spacer, bush, synchro hub and 2nd gear from the mainshaft.

49 *Checking 5th gear end-float.* Fit the 5th gear assembly to the mainshaft, i.e. front spacer, 5th gear, synchro hub, rear plate and spacer. Fit an old circlip and using feeler gauges check the end-float which should be within 0.005 to 0.055 mm (0.0002 to 0.002 in). The rear spacer is available in a range of sizes. Select a rear spacer which will ensure the required clearance.

50 Remove the circlip spacer and 5th gear assembly.

**Assembly**

51 It is important that 1st/2nd synchro is assembled correctly (short splines on inner member) towards 2nd gear. Fit 2nd gear, baulk ring, synchro hub and sleeve (selector fork annulus to rear of gearbox), baulk ring, 1st gear and selective bush, bearing and a new circlip. When fitting the circlip care must be taken to ensure that it is not stretched (opened) beyond the *minimum* necessary to obtain entry over the shaft. The internal diameter of an expanded circlip *must not* exceed 32.30 mm.

52 Fit 3rd gear, baulk ring, and synchro hub and sleeve (longer boss of synchro hub to front of gearbox) to the mainshaft.

53 Fit the spacer and bearing to front of mainshaft.

54 Fit the layshaft bearing track to the centre plate.

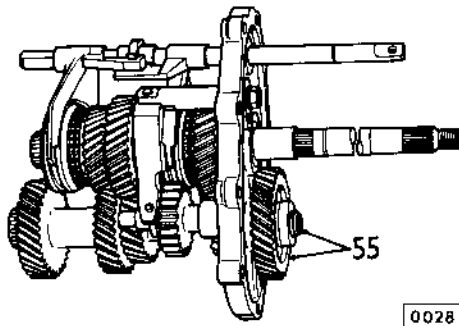

55 Fit the layshaft to the centre plate and fit the fifth gear, spacer and a new circlip. When fitting the circlip care must be taken to ensure that it is not stretched (opened) beyond the *minimum* necessary to obtain entry. The internal diameter of an expanded circlip *must not* exceed 22.5 mm.

56 Fit the mainshaft bearing track to the centre plate.

57 Locate the centre plate in protected vice jaws.

58 Take the selector shaft complete with 1st and 2nd selector fork, front spool and 3rd and 4th selector fork and engage both forks in their respective synchro sleeves on the mainshaft. Simultaneously engage the selector shaft and mainshaft assemblies in the centre plate.

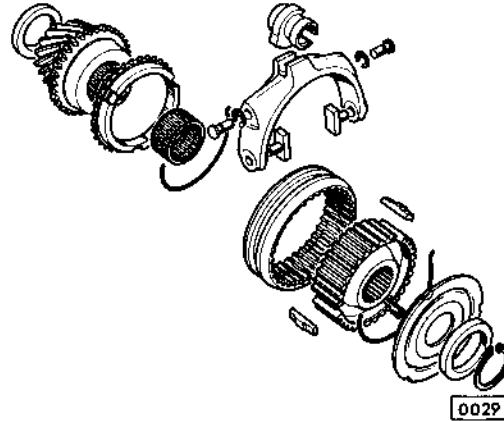

59 Fit the spacer, 5th gear, baulk ring, synchro hub and sleeve end-plate, selective spacer (instruction 48), and a new circlip. When fitting the circlip care must be taken to ensure that it is not stretched (opened) beyond the *minimum* necessary to obtain entry. The internal diameter of an expanded circlip *must not* exceed 27.63 mm.

60 Fit the reverse gear (lip for slipper pad to front of box) front and rear spacers and the reverse shaft.

61 Fit the reverse lever, slipper pad, pivot pin and circlip. If a new reverse gear pivot shaft is to be fitted it is

necessary to ensure that its radial location is consistent with reverse pad slipper engagement/clearance. Radial location is determined on assembly. Secure with spring washer and nuts, subsequently checking movement of reverse lever and ensuring slipper pad is properly engaged.

62 Remove the centre plate and gear assembly from the vice and locate on a suitable stand with the front of the mainshaft vertically uppermost. Ensure that the reverse shaft does not slide out of position.

63 Fit the centre plate front gasket.

64 Fit the external bearing and internal bearing track to the input shaft.

65 Fit the input shaft to the gearcase.

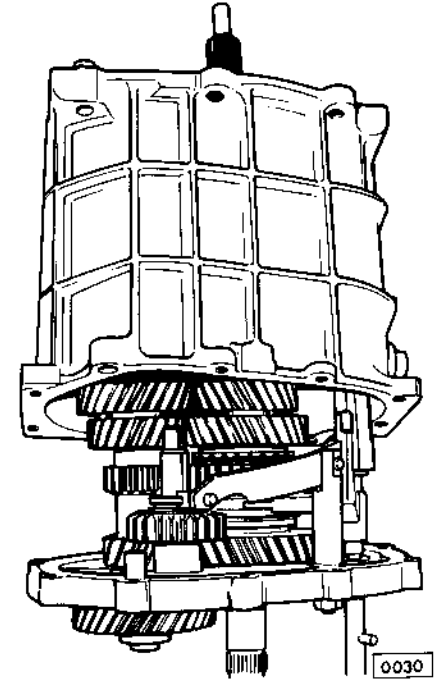

66 Carefully slide the gearcase and input shaft into position over the gear assemblies. Do not use force. Ensure that the centre plate dowels and selector shaft are engaged in their respective locations.

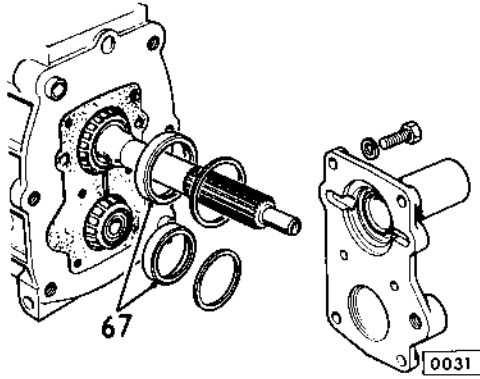

- 67 Fit the layshaft and input shaft bearing outer tracks.
- 68 Using seven slave bolts and plain washers to prevent damaging the rear face of the centre plate evenly draw the gearcase into position on the centre plate.

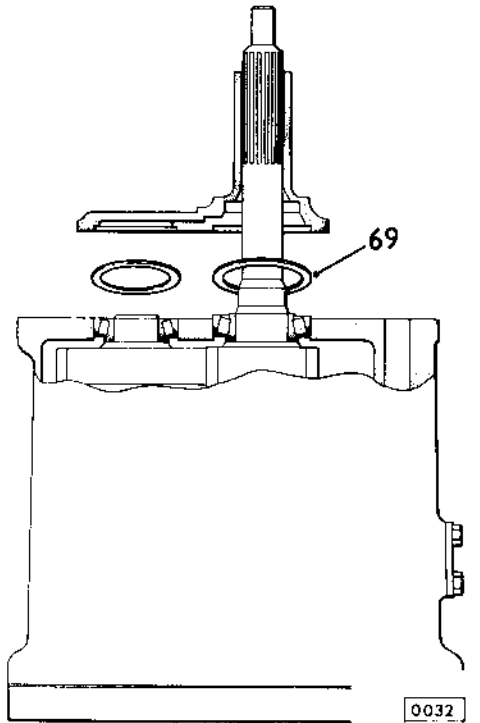

- 69 Place a layshaft spacer of nominal thickness (0.040 in, 1.02 mm) on the layshaft bearing track, and fit the front cover and gasket, securing with six bolts.
- 70 Using a dial gauge check layshaft end-float.
- 71 Remove the front cover and provisional spacer. The required layshaft end-float is 0.005 to 0.055 mm (0.0002 to 0.002 in). Check the thickness of the provisional spacer. Spacer thickness required is: provisional spacer thickness, plus end-float obtained, minus 0.055 mm (0.002 in).
- 72 Again fit the front cover and gasket, this time with the correct spacer arrived at in instruction 71.
- 73 Check layshaft end-float to ensure it is within the limits specified in instruction 71.
- 74 Place a ball bearing in the centre of the input shaft. This facilitates checking mainshaft end-float using a dial gauge.
- 75 Mount the dial gauge on the gearcase with the stylus resting on the ball. Zero the gauge.
- 76 Check the mainshaft and input shaft combined end-float. Care must be taken when checking dial gauge readings to ensure that end-float only – as distinct from side movement of the input shaft – is recorded. If difficulty is encountered in differentiating between end-float and side movement remove the front cover and wrap the plain portion of the input shaft below the splines with six turns of masking tape. Refit the front cover and again check end-float ensuring that rise and fall of the input shaft is not restricted by the tape.
- 77 Having ascertained end-float select the spacer required as follows:  
End-float minus 0.055 mm (0.002 in) – spacer thickness required. Fit the spacer thus determined and again check end-float which must be within 0.005 to 0.055 mm (0.0002 to 0.002 in).
- 78 Remove the front cover and tape (if employed).

- 79 Fit the oil seal to the front cover and lubricate the seal lips.
- 80 Mask the splines and fit the front cover. Remove the splines masking.
- 81 Place the gearbox on a bench or stand and remove the slave bolts and washers from the centre plate.
- 82 Fit the 5th gear spool and circlip to the selector shaft.  
**NOTE:** The longer cam of the spool is fitted towards the bottom of the gearbox.
- 83 Fit the 5th gear selector fork and bracket.
- 84 Renew the selector shaft 'O' ring in the rear cover and fit the oil ring bush.
- 85 Fit the rear gasket to the centre plate and engage the oil pump shaft in the layshaft.

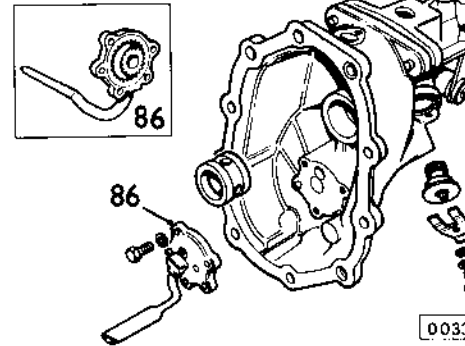

- 86 Fit the oil pump gears and cover to the gearbox rear cover.
- 87 Fit the rear cover ensuring that the oil pump shaft engages the oil pump.
- 88 Fit the selector shaft ball, spring and plug to the centre plate.
- 89 Fit the spool locating bosses (2) to the 1st/2nd spool and 5th gear spool.
- 90 Fit the speedometer driving gear to the mainshaft ensuring that it properly engages the mainshaft flats.
- 91 Fit the circlip and sleeve and ball race to the mainshaft.
- 92 Fit the rear oil seal. Lubricate seal lip.
- 93 Fit the driving flange, washer and nut.
- 94 Fit the speedometer driven gear and housing.
- 95 Fit the bell housing.
- 96 Fit the clutch release bearing and withdrawal lever.
- 97 Fit the remote control housing.

## FIRST MOTION SHAFT OIL SEAL

Remove and refit

37.23.04

Service tools: ST 1136

### Removing

- 1 Remove the gearbox, see 37.20.01.

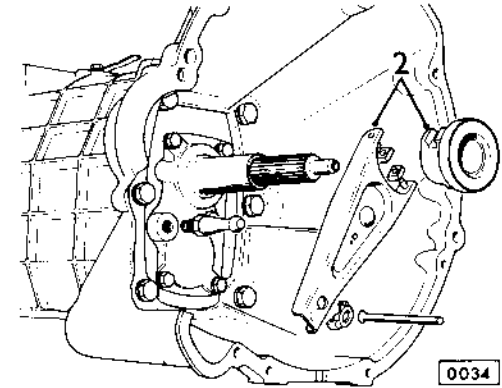

- 2 Using tool ST 1136 remove the clutch release fork and bearing.
- 3 Remove the bolts and washers securing the front cover to the gearbox.
- 4 Remove the front cover and gasket.

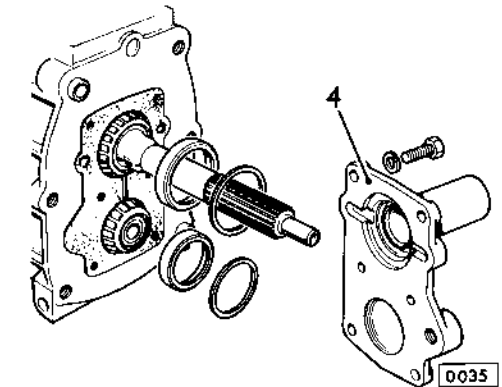

- 5 Remove the oil seal from the front cover. Ensure that the spacers for the first motion shaft and layshaft bearings are not intermixed.

continued

**Refitting**

- 6 Fit a new oil seal to the front cover (seal lip towards gearbox).
- 7 Lubricate the oil seal and fit the front cover and gasket.
- 8 Fit the clutch release fork and bearing.
- 9 Fit the gearbox to the car, see 37.20.01.

**SPEEDOMETER DRIVE GEAR**

Remove and refit 37.25.01

As Operation 37.12.42.

**SPEEDOMETER DRIVE PINION**

Remove and refit 37.25.05

**Removing**

- 1 Remove the bolt and washer securing the speedometer clamp plate.
- 2 Release the speedometer cable from the drive pinion.
- 3 Withdraw the pinion housing and pinion from the gearbox.
- 4 Remove the pinion from the housing.

**Refitting**

- 5 Reverse instructions 1 to 4. Renew the pinion housing 'O' ring if necessary.

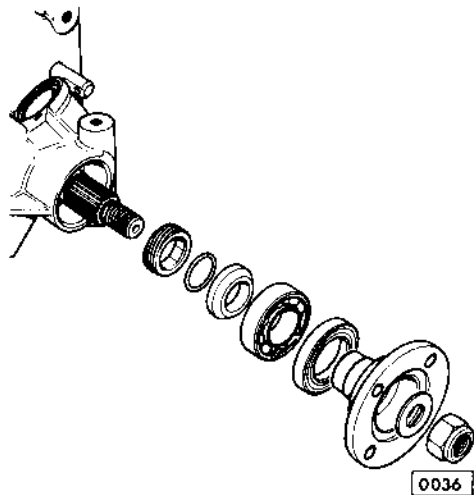

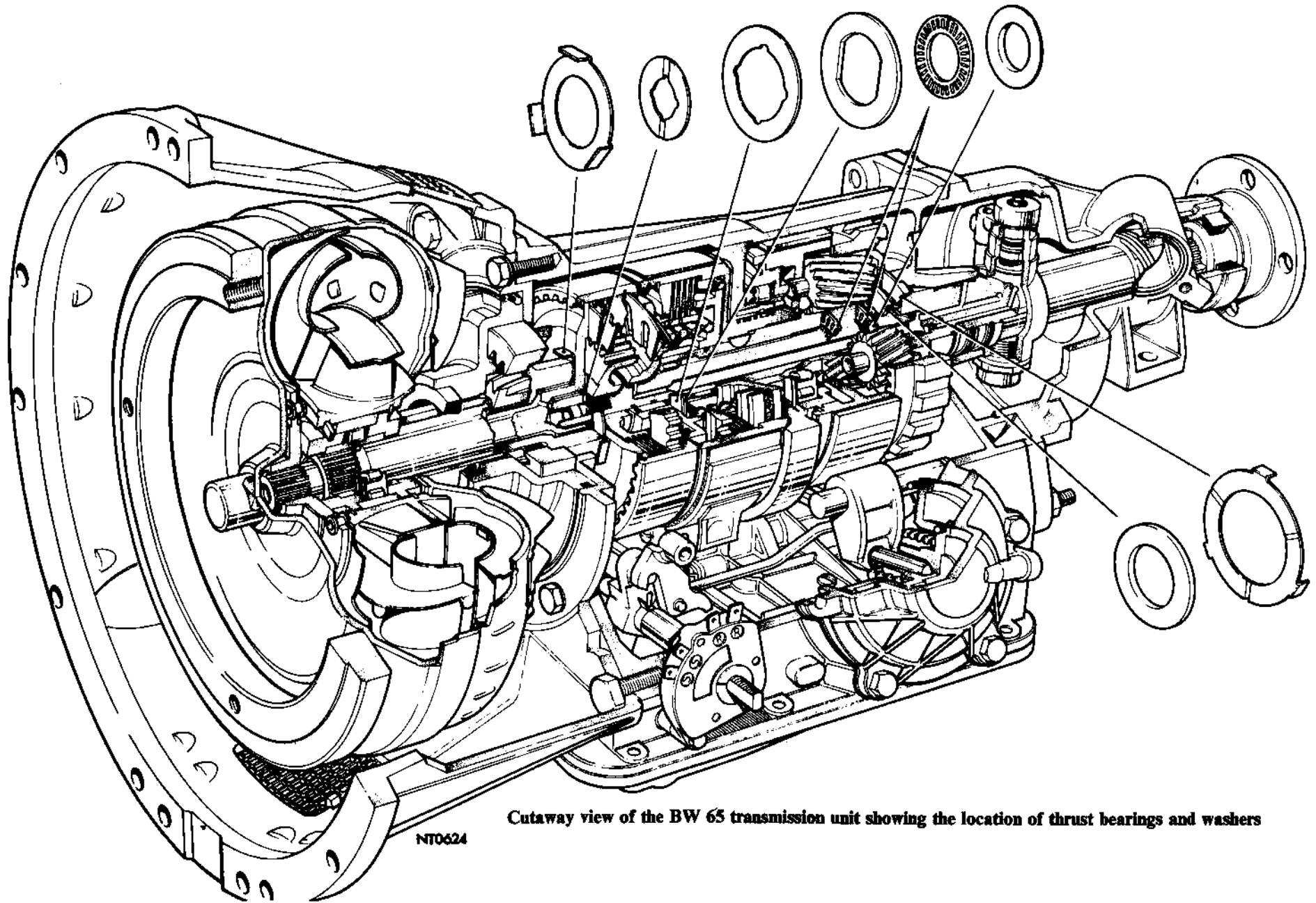

Cutaway view of the BW 65 transmission unit showing the location of thrust bearings and washers

NT0624

**IMPORTANT**

Under agreements existing between Borg-Warner Limited and the car manufacturers, the former does NOT undertake the servicing of automatic transmission units, nor do they supply spare parts or service tools. All matters appertaining to service or spares must therefore be dealt with by Triumph Distributors or Dealers within the organisation.

TYPE – Borg-Warner 65 Unit – P.R.N.D.2.1. System

**UNIT IDENTIFICATION**

A serial number prefix 027 appears on a dark admiralty grey nameplate on the left hand side of the transmission case.

**AUTOMATIC TRANSMISSION – SHIFT SPEEDS**

Throttle Position	Zero Throttle	Light Throttle		Part Throttle	KICK-DOWN						
		2	D	D	D	D	D	1	D	2	2
Selector	-1	2	D	D	D	D	D	1	D	2	2
Shift	2-1	1-2	2-3	3-2	1-2	2-3	3-2	2-1	3-1	1-2	2-1
Road Speed M P H	30-38	8-12	12-16	30-40	38-44	65-71	58-66	42-50	30-38	38-44	30-38
KM/H	48-61	13-19	13-26	48-64	61-71	105-114	93-106	68-81	48-61	61-71	48-61

Capacity 5.3 Litres (9½ pints) including cooler of 0.3 litres (½ pint)

**TRANSMISSION DATA**

	TOP (3rd)	Intermediate (2nd)	Low (1st)	Reverse
Gearbox ratios	1:1	1.45:1	2.39:1	2.09:1
Converter reduction (1.91)	Infinitely variable between operating in all gears		1-1.91:1	
<b>OVERALL RATIOS</b>	3.27:1	4.74:1	7.83:1	6.85:1

217 K Converter – dia 242 mm (9½") – RATIO 1.91:1

**EXAMINATION OF COMPONENTS****Transmission Case and Servo Covers**

Check for cracks and obstructions in passages.

**Front and Rear Pump**

Check for scoring and excessive wear.

**Shafts**

Check bearing and thrust faces for scoring.

**Clutch Plates**

Check for warping, scoring, overheating and excessive wear.

**Bands**

Check for scoring, overheating and excessive wear.

**Drums**

Check for overheating and scoring.

**Gears**

Check teeth for chipping, scoring, wear and condition of thrust faces.

**Uni-directional Clutch and Races**

Check for scoring, overheating and wear.

**Valve Block and Governor**

Check for burrs, crossed or stripped threads, and scored sealing faces.

**Impeller Hub and Front Pump Drive Gear**

Check for pitting and wear. Ensure good contact.

**Thrust Washers**

Check for burrs, scoring and wear.

**White Metal Bushes**

Check for scoring and loss of white metal.

**Lip Seals**

Check for cuts, hardening of rubber, leakage past outer diameter.

**Rubber 'O' Rings and Seals**

Check for hardening, cracking, cuts or damage.

**Cast Iron Sealing Rings**

Check fit in groove and wear (evident by lip overhanging the groove).

**Teflon Sealing Rings**

Check for cracking, cuts or damage.

**SERVICING REQUIREMENTS**

- 1 For all operations high standards of cleanliness are essential.
  - 2 Rags and cloths must be clean and free from lint; nylon cloths are preferable.
  - 3 Prior to assembly all components must be cleaned thoroughly with petrol, paraffin or an industrial solvent.
  - 4 All defective items must be renewed.
  - 5 Components should be lubricated with transmission fluid before assembly.
  - 6 New joint washers should be fitted where applicable.
  - 7 Where jointing compound is required, the use of Hylomar SQ32M, Hermetite or Wellseal is approved.
  - 8 All screws, bolts and nuts must be tightened to the recommended torque figure.
  - 9 Thrust washers and bearings should be coated with petroleum jelly to facilitate retaining them in position during assembly operations. Grease should not be used as it may be insoluble in the transmission fluid and could subsequently cause blockage of fluid passages and contamination of brake band and clutch facings.
- IMPORTANT:** Metric threads are used throughout most of the transmission unit and it is therefore essential that fastenings, and especially lock washers, are segregated into sets and not inter-mixed with those from other parts of the vehicle.



## FRONT BRAKE BAND

Remove and refit 44.10.01

Service tools: CBW 60, CBW 547A-50

### Removing

- 1 Remove the transmission unit. 44.20.01.
- 2 Wash the exterior of the unit in clean petrol or paraffin, invert it and place on a bench cradle CBW 60. Remove the switch. 44.15.15.
- 3 Unscrew the bolts securing the torque converter housing.
- 4 Remove the torque converter housing.
- 5 Unscrew 12 bolts.
- 6 Remove the oil pan, joint washer and magnet.

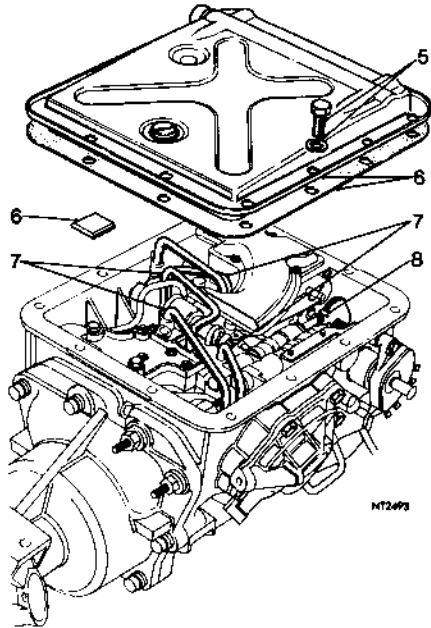

- 7 Pull out the five oil tubes.
- 8 Release the downshift inner cable from the downshift cam.
- 9 Take out three bolts and washers.
- 10 Lift off the valve block.
- 11 Unscrew two bolts.
- 12 Remove the oil tube locating plate.
- 13 Pull out the oil tubes. (Note the 'O' ring on the pump suction tube.)
- 14 Take out five bolts.

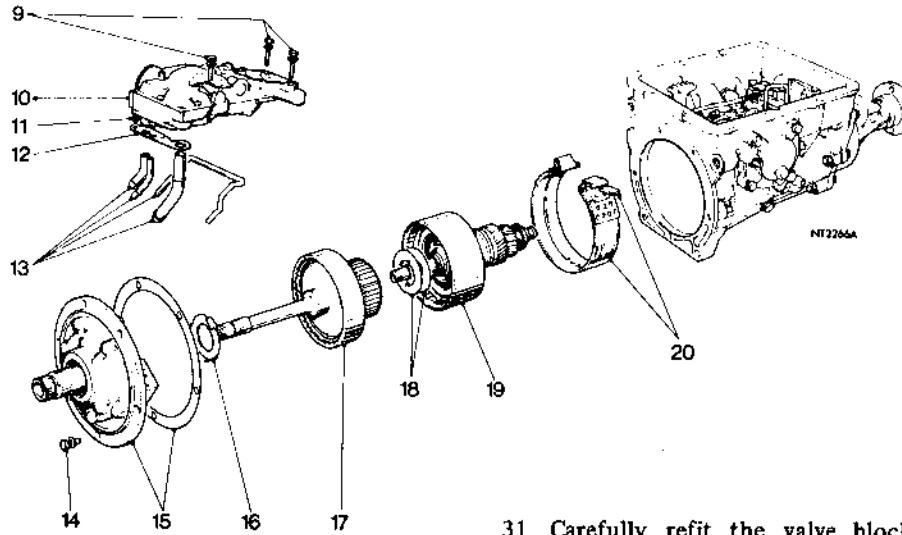

- 15 Remove the pump and joint washer.
- 16 Remove the thrust washer.
- 17 Withdraw the front clutch.
- 18 Remove the thrust washers.
- 19 Withdraw the rear clutch and forward sun gear.
- 20 Squeeze together the ends of the front brake band and remove it together with the strut.

### Refitting

- 21 Squeeze together the ends of the front brake band and fit it in position together with the strut.
- 22 Refit the rear clutch and forward sun gear assembly.
- 23 Using petroleum jelly, stick the thrust washers to the rear clutch assembly (phosphor bronze towards the front clutch).
- 24 Refit the front clutch assembly.
- 25 Using petroleum jelly, stick the thrust washer to the pump assembly.
- 26 Refit the pump assembly and joint washer.
- 27 Fit and tighten the bolts.
- 28 Refit the oil tubes. (Note the 'O' ring on the pump suction tube.)
- 29 Refit the oil tube locating plate.
- 30 Fit and tighten the two bolts.

- 31 Carefully refit the valve block, ensuring that the oil tubes are not distorted.
- 32 Fit and tighten the three bolts and washers.
- 33 Connect the downshift inner cable to the downshift cam.
- 34 Refit the five oil tubes.
- 35 Replace the magnet and refit the oil pan and joint washer.
- 36 Fit and tighten 12 bolts.

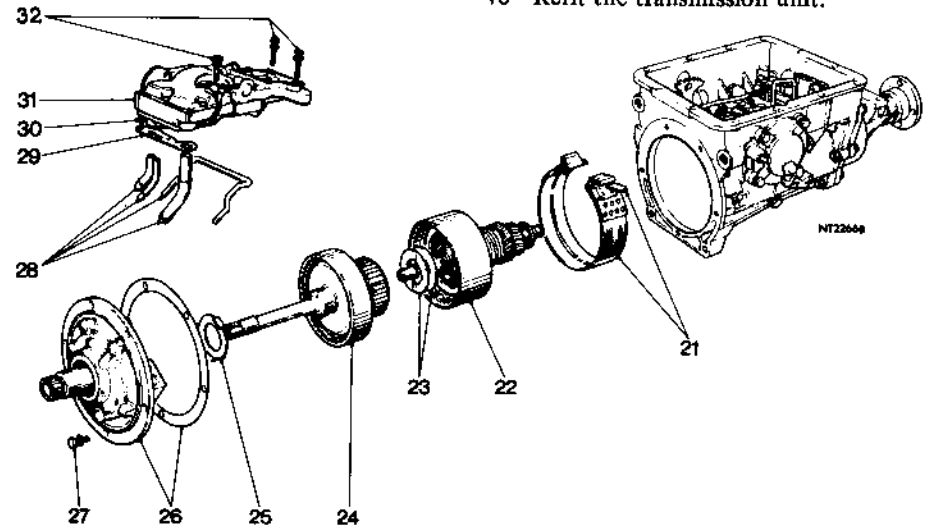

- 37 Locate the torque converter housing in place.
- 38 Fit and tighten four bolts securing the torque converter housing.
- 39 Refit the switch 44.15.15.
- 40 Refit the transmission unit.

**REAR BRAKE BAND**

Remove and refit 44.10.09

Service tools: CBW 60, CBW 547A-50

**Removing**

- 1 Remove the transmission unit, 44.20.01.
- 2 Wash the exterior of the unit in clean petrol or paraffin, invert it and place on a bench cradle CBW 60. Remove the switch, 44.15.15.
- 3 Unscrew the bolts securing the torque converter housing.
- 4 Remove the torque converter housing.
- 5 Unscrew 12 bolts.
- 6 Remove the oil pan, joint washer and magnet.
- 7 Pull out the oil tubes.
- 8 Release the downshift inner cable from the downshift cam.
- 9 Take out three bolts and washers.
- 10 Lift off the valve block.
- 11 Unscrew two bolts.
- 12 Remove the oil tube locating plate.
- 13 Pull out the oil tubes. (Note the 'O' ring on the pump suction tube.)
- 14 Take out five bolts.
- 15 Remove the pump and joint washer.
- 16 Remove the thrust washer.
- 17 Withdraw the front clutch.
- 18 Remove the thrust washers.
- 19 Withdraw the rear clutch and forward sun gear.
- 20 Squeeze together the ends of the front brake band and remove it together with the strut.
- 21 Unscrew the bolts.
- 22 Withdraw the centre support/planet gear assembly and thrust race.
- 23 Squeeze together the ends of the rear

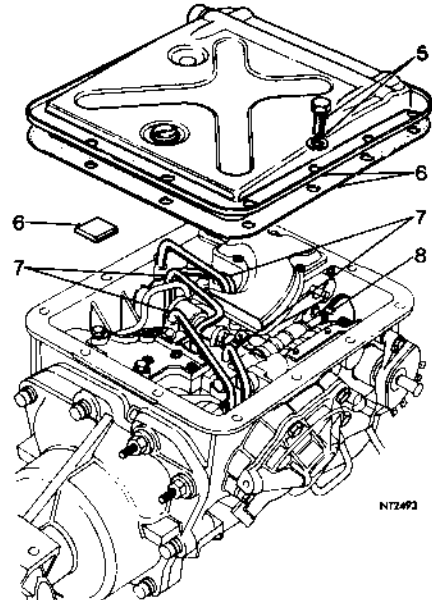

brake band, tilt and withdraw it from the casing together with the strut.

**Refitting**

- 24 Refit the rear brake band and strut.

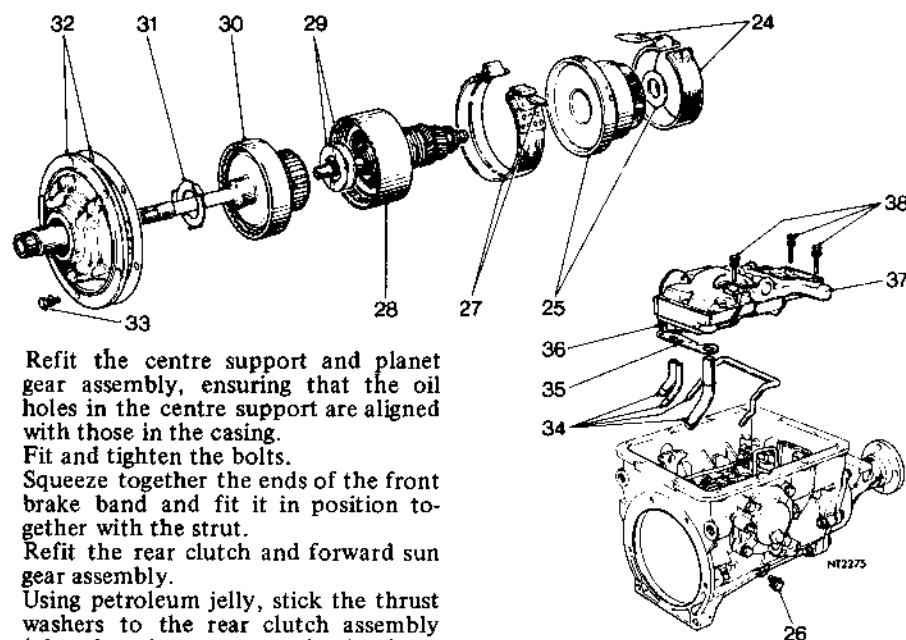
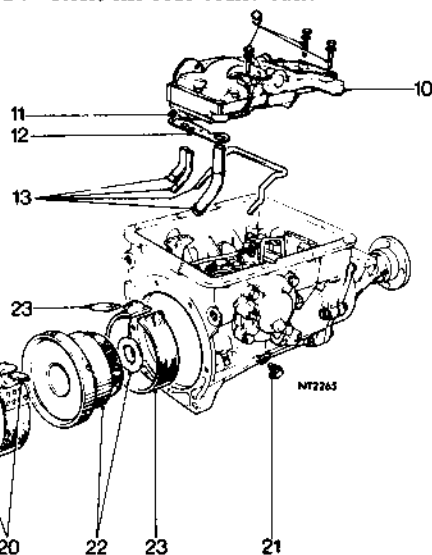

- 25 Refit the centre support and planet gear assembly, ensuring that the oil holes in the centre support are aligned with those in the casing.
- 26 Fit and tighten the bolts.
- 27 Squeeze together the ends of the front brake band and fit it in position together with the strut.
- 28 Refit the rear clutch and forward sun gear assembly.
- 29 Using petroleum jelly, stick the thrust washers to the rear clutch assembly (phosphor bronze towards the front clutch).
- 30 Refit the front clutch assembly.
- 31 Using petroleum jelly, stick the thrust washer to the pump assembly.
- 32 Refit the pump assembly and joint washer.
- 33 Fit and tighten the bolts.
- 34 Refit the oil tubes. (Note the 'O' ring on the pump suction tube.)
- 35 Refit the oil tube locating plate.
- 36 Fit and tighten the two bolts.
- 37 Carefully refit the valve block, ensuring that the oil tubes are not distorted.
- 38 Fit and tighten the three bolts and washers.
- 39 Connect the downshift inner cable to the downshift cam.
- 40 Refit the oil tubes.
- 41 Replace the magnet and refit the oil pan and joint washer.
- 42 Fit and tighten 12 bolts.
- 43 Locate the torque converter housing in place.
- 44 Fit and tighten four bolts securing the torque converter housing.
- 45 Refit the switch, 44.15.15.
- 46 Refit the transmission unit, 44.20.01.

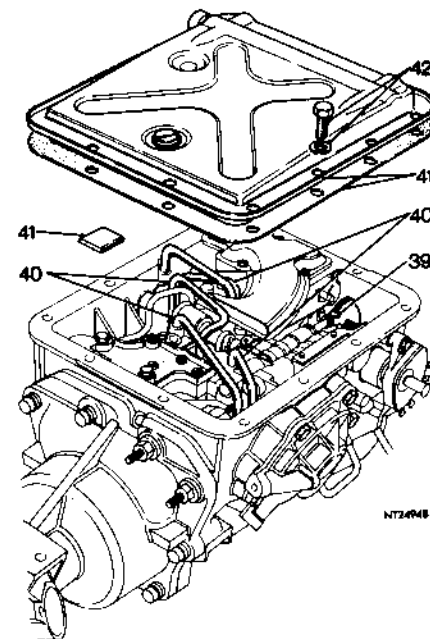

## FRONT CLUTCH

### Remove and refit

44.12.04

Service tools: CBW 60, CBW 547A-50

### Removing

- 1 Remove the transmission unit. 44.20.01.
- 2 Wash the exterior of the unit in clean petrol or paraffin, invert it and place on a bench cradle CBW 60. Remove the switch. 44.15.15.
- 3 Unscrew the bolts securing the torque converter housing.
- 4 Remove the torque converter housing.
- 5 Unscrew 12 bolts.
- 6 Remove the oil pan, joint washer and magnet.
- 7 Pull out the oil tubes.
- 8 Release the downshift inner cable from the downshift cam.
- 9 Take out three bolts and washers.
- 10 Lift off the valve block.
- 11 Unscrew two bolts.
- 12 Remove the oil tube locating plate.
- 13 Pull out the oil tubes. (Note the 'O' ring on the pump suction tube.)
- 14 Take out five bolts.
- 15 Remove the pump joint washer.
- 16 Remove the thrust washer.
- 17 Withdraw the front clutch.
- 18 Remove the thrust washers.

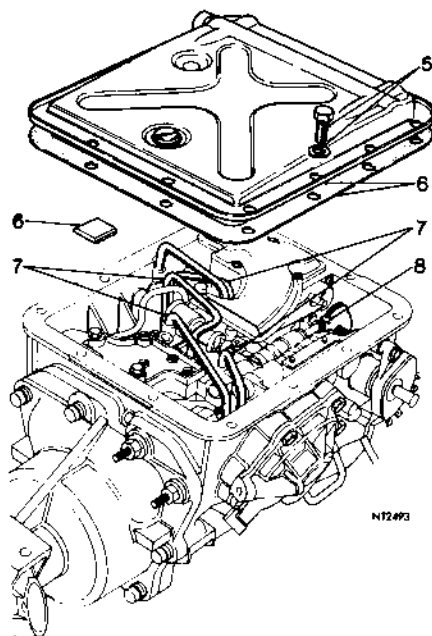

NT2493

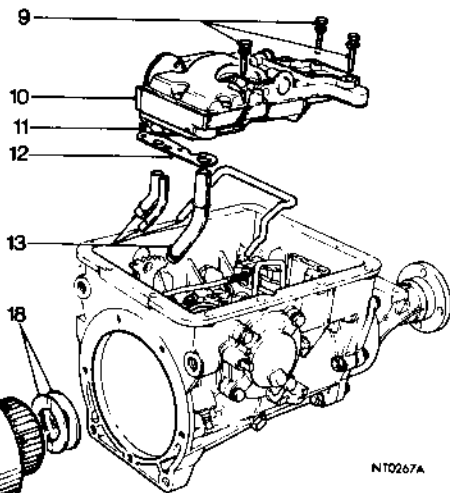

NT0267A

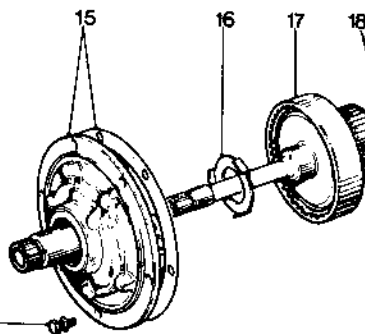

14

### Refitting

- 19 Using petroleum jelly, stick the thrust washers to the rear clutch assembly (phosphor bronze towards the front clutch).
- 20 Refit the front clutch assembly.
- 21 Using petroleum jelly, stick the thrust washer to the pump assembly.
- 22 Refit the front assembly and joint washer.

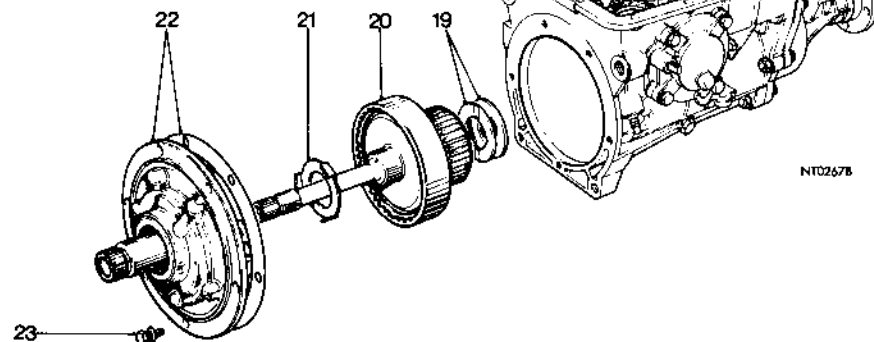

NT0267B

- 23 Fit and tighten the bolts.
- 24 Refit the oil tubes. (Note the 'O' ring on the pump suction tube.)
- 25 Refit the oil tube locating plate.
- 26 Fit and tighten the two bolts.
- 27 Carefully refit the valve block, ensuring that the oil tubes are not distorted.
- 28 Fit and tighten the three bolts and washers.
- 29 Connect the downshift inner cable to the downshift cam.
- 30 Refit the oil tubes.
- 31 Replace the magnet and refit the oil pan and joint washer.
- 32 Fit and tighten the 12 bolts.
- 33 Locate the torque converter housing in place.
- 34 Fit and tighten four bolts securing the torque converter housing.
- 35 Refit the switch. 44.15.15.
- 36 Refit the transmission unit. 44.20.01.

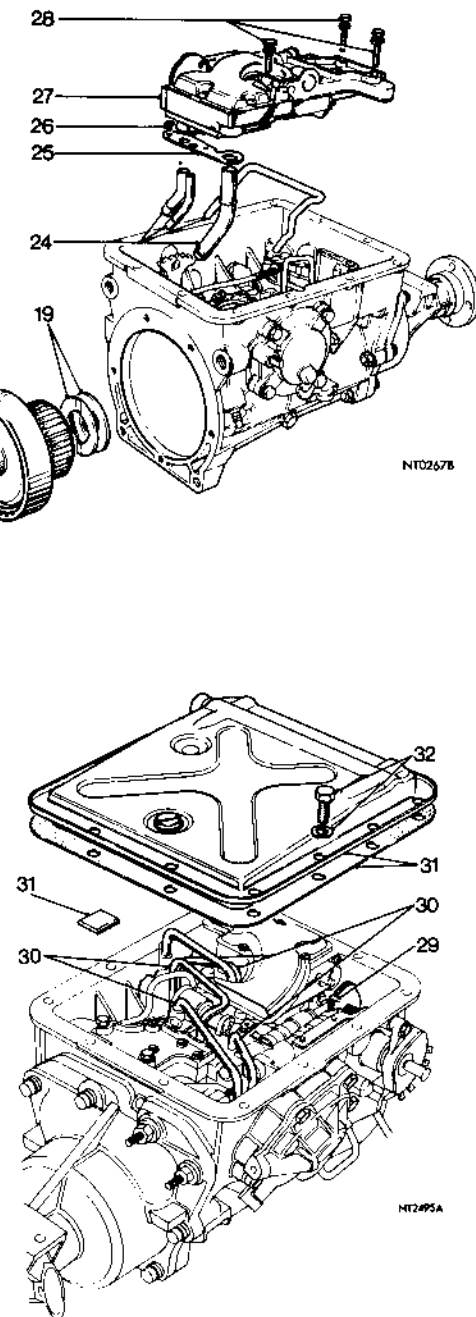

NT2495A

**REAR CLUTCH**

Remove and refit

44.12.07

Service tools: CBW 60, CBW 547A-50

**Removing**

- 1 Remove the transmission unit. 44.20.01.
- 2 Wash the exterior of the unit in clean petrol or paraffin, invert it and place on a bench cradle CBW 60. Remove the switch. 44.15.15.
- 3 Unscrew the bolts securing the torque converter housing.
- 4 Remove the torque converter housing.
- 5 Unscrew 12 bolts.
- 6 Remove the oil pan, joint washer and magnet.
- 7 Pull out the oil tubes.
- 8 Release the downshift inner cable from the downshift cam.
- 9 Take out three bolts and washers.
- 10 Lift off the valve block.
- 11 Unscrew two bolts.
- 12 Remove the oil tube locating plate.
- 13 Pull out the oil tubes. (Note the 'O' ring on the pump suction tube.)
- 14 Take out five bolts.
- 15 Remove the pump and joint washer.
- 16 Remove the thrust washer.
- 17 Withdraw the front clutch.
- 18 Remove the thrust washers.
- 19 Withdraw the rear clutch and forward sun gear.
- 20 Separate the forward sun gear assembly from the rear clutch.

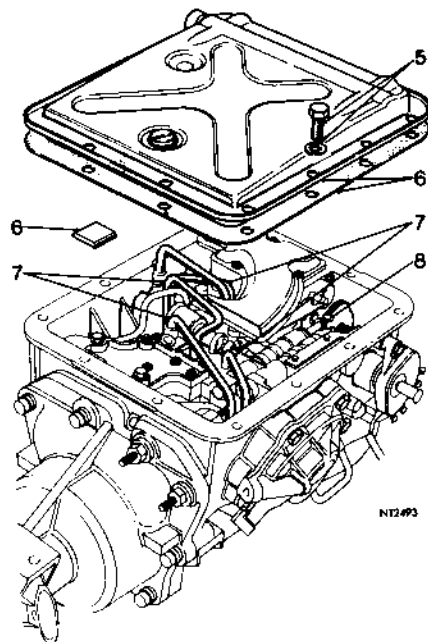

NT2493

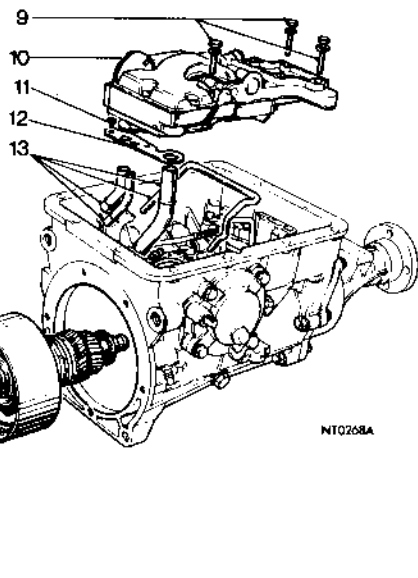

NT0268A

**Refitting**

- 21 Assemble the forward sun gear to the rear clutch.
- 22 Refit the rear clutch and forward sun gear assembly.
- 23 Using petroleum jelly, stick the thrust washers to the rear clutch assembly (phosphor bronze towards the front clutch).
- 24 Refit the front clutch assembly.
- 25 Using petroleum jelly, stick the thrust washer to the pump assembly.
- 26 Refit the pump assembly and joint washer.
- 27 Fit and tighten the bolts.
- 28 Refit the oil tubes. (Note the 'O' ring on the pump suction tube.)
- 29 Refit the oil tube locating plate.
- 30 Fit and tighten the two bolts.
- 31 Carefully refit the valve block, ensuring that the oil tubes are not distorted.
- 32 Fit and tighten the three bolts and washers.
- 33 Connect the downshift inner cable to the downshift cam.
- 34 Refit the oil tubes.
- 35 Replace the magnet and refit the oil pan and joint washer.
- 36 Fit and tighten 12 bolts.
- 37 Locate the torque converter housing in place.
- 38 Fit and tighten four bolts securing the torque converter housing.
- 39 Refit the switch. 44.15.15.
- 40 Refit the transmission unit. 44.20.01.

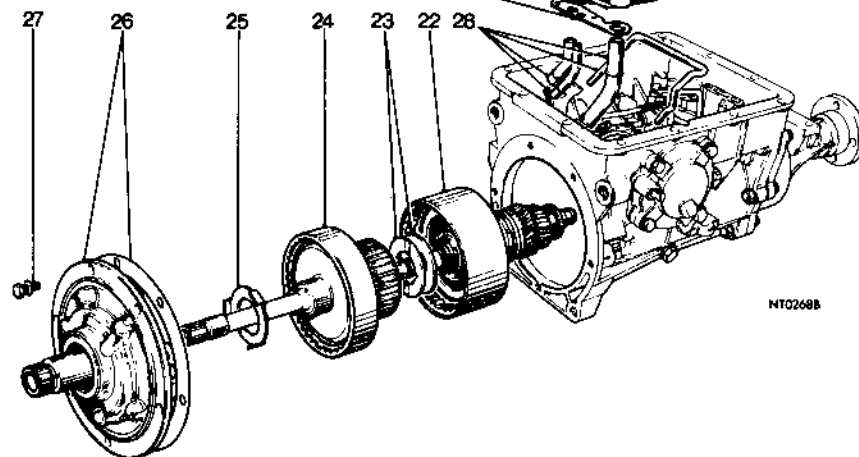

NT0268B

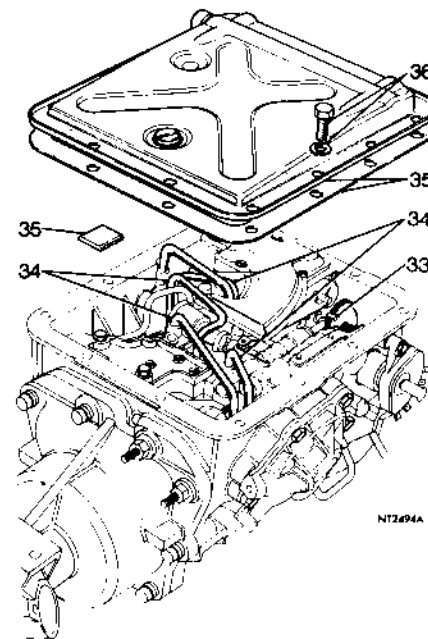

NT2494A

## FRONT CLUTCH

### Overhaul

44.12.10

Service tool: BW 42

1 Remove the front clutch. 44.12.04.

### Dismantling

- 2 Remove the circlip.
- 3 Withdraw the input shaft.
- 4 Remove the thrust washer.
- 5 Remove the hub.
- 6 Take out the inner and outer friction plates.
- 7 Remove the pressure plate.
- 8 Remove the circlip.
- 9 Take out the spring.
- 10 Remove the spring bearing.
- 11 Withdraw the piston. (If necessary, blank off the bores of the clutch drum and apply a compressed air line to the piston valve hole.)
- 12 Remove the seal from the piston.
- 13 Remove the 'O' ring from the drum.

### Reassembling

- 14 Refit the 'O' ring to the drum.
- 15 Refit the seal to the piston.
- 16 Fit the piston into tool no. BW 42 and place the tool in the drum. Push the piston into the drum and remove the tool.
- 17 Locate the spring bearing in position.
- 18 Refit the spring.

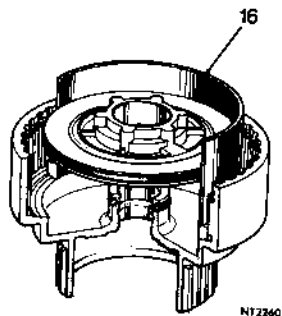

NT2286

- 19 Fit the circlip.
- 20 Refit the pressure plate.
- 21 Refit the hub.
- 22 Fit the inner and outer friction plates in alternate sequence.
- 23 Using petroleum jelly, stick the thrust washer to the hub.
- 24 Locate the input shaft in position.
- 25 Refit the circlip.
- 26 Refit the front clutch. 44.12.04.

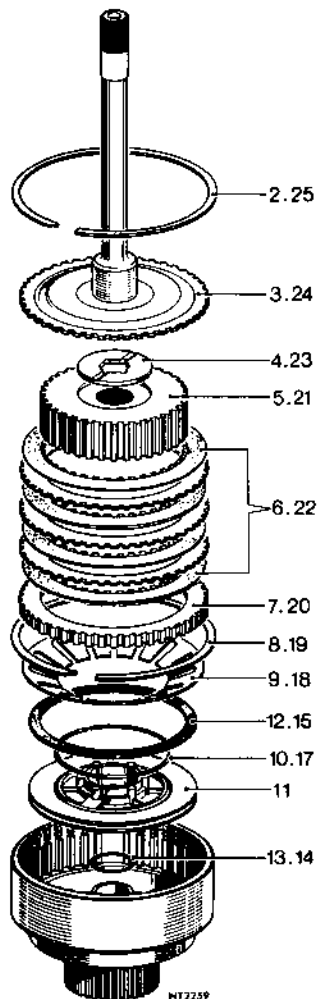

NT2259

## REAR CLUTCH

### Overhaul

44.12.13

Service tools: BW 37A, BW 41.

1 Remove the rear clutch. 44.12.07.

### Dismantling

- 2 Remove the circlip.
- 3 Take out the pressure plate.
- 4 Remove the inner and outer friction plates.
- 5 Using tool BW 37A as shown, compress the spring and remove the spring seat circlip. Remove the tool.
- 6 Take out the spring seat.
- 7 Remove the spring.
- 8 Withdraw the piston.
- 9 Remove the rubber sealing ring from the piston.
- 10 Remove the rubber 'O' ring from the drum.

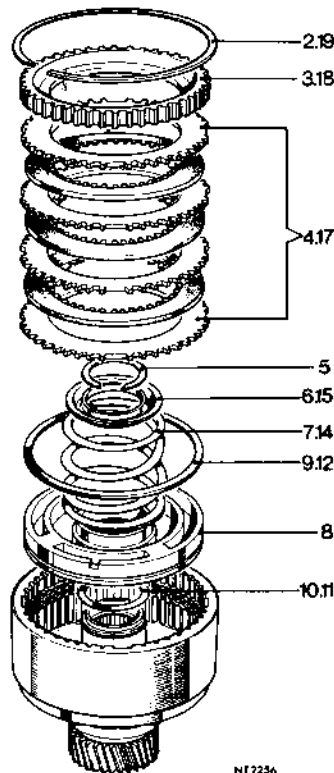

NT2256

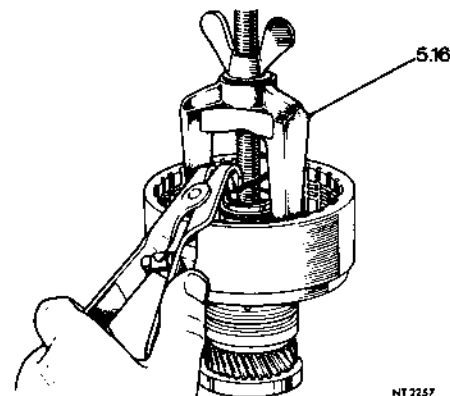

NT2257

### Reassembling

- 11 Fit the 'O' ring to the drum.
- 12 Fit the sealing ring to the piston drum.
- 13 Fit the piston assembly into tool BW 41 and locate the tool in the drum. Push the piston into the drum. Remove the tool.
- 14 Refit the spring.
- 15 Refit the spring seat.
- 16 Using tool BW 37A, compress the spring and fit the circlip. Remove the tool.
- 17 Refit the inner and outer clutch plates in alternate sequence.
- 18 Fit the pressure plate.
- 19 Refit the circlip.
- 20 Refit the rear clutch. 44.12.07.

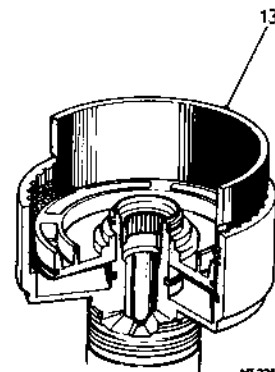

NT2258

## UNI-DIRECTIONAL CLUTCH

Remove and refit 44.12.16

Service tools: CBW 60, CBW 547A-50

## Removing

- 1 Remove the transmission unit, 44.20.01.
- 2 Wash the exterior of the unit in clean petrol or paraffin, invert it and place on a bench cradle CBW 60. Remove the switch, 44.15.15.
- 3 Unscrew the bolts securing the torque converter housing.
- 4 Remove the torque converter housing.
- 5 Unscrew 12 bolts.
- 6 Remove the oil pan, joint washer and magnet.
- 7 Pull out the oil tubes.
- 8 Release the downshift inner cable from the downshift cam.
- 9 Take out three bolts and washers.
- 10 Lift off the valve block.
- 11 Unscrew two bolts.
- 12 Remove the oil tube locating plate.
- 13 Pull out the oil tubes. (Note the 'O' ring on the pump suction tube.)
- 14 Take out five bolts.
- 15 Remove the pump and joint washer.
- 16 Remove the thrust washer.
- 17 Withdraw the front clutch.
- 18 Remove the thrust washer.
- 19 Withdraw the rear clutch and forward sun gear.

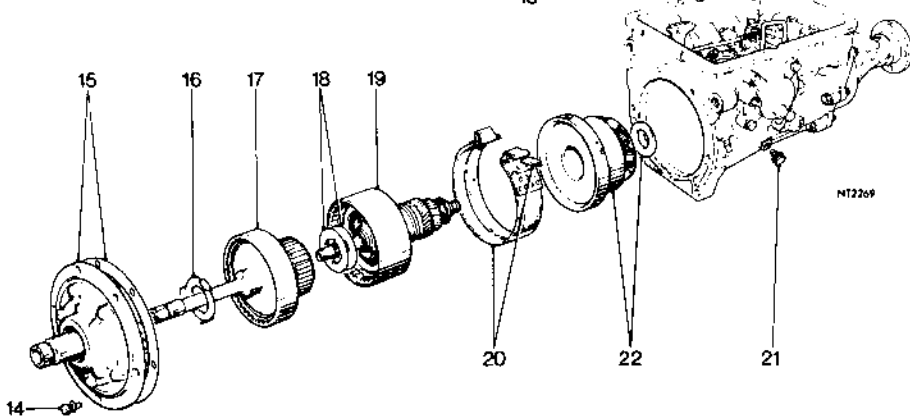
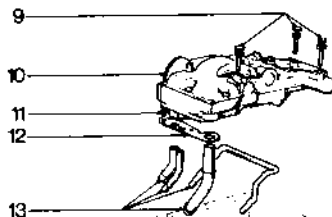
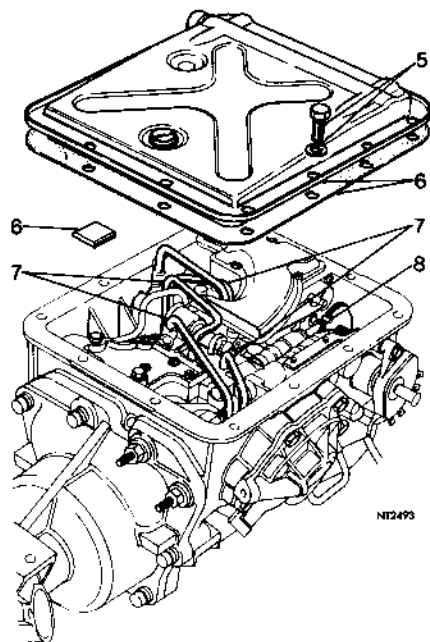

- 20 Squeeze together the ends of the front brake band and remove it together with the strut.
- 21 Unscrew the bolts.
- 22 Withdraw the centre support/planet gear assembly.
- 23 Separate the centre support from the planet gear assembly.
- 24 Withdraw the uni-directional clutch.
- 25 Remove the circlip.
- 26 Remove the uni-directional clutch outer race.

## Refitting

- 27 Refit the uni-directional clutch outer race to the rear drum.
- 28 Refit the circlip.
- 29 Refit the uni-directional clutch.
- 30 Assemble the centre support and planet gear assembly.
- 31 Refit the assembly, ensuring that the oil and locating holes in the centre support align with those in the casing.
- 32 Fit and tighten three bolts.
- 33 Squeeze together the ends of the front brake band and fit it in position together with the strut.
- 34 Refit the rear clutch and forward sun gear assembly.
- 35 Using petroleum jelly, stick the thrust washer to the rear clutch assembly (phosphor bronze towards the front clutch).

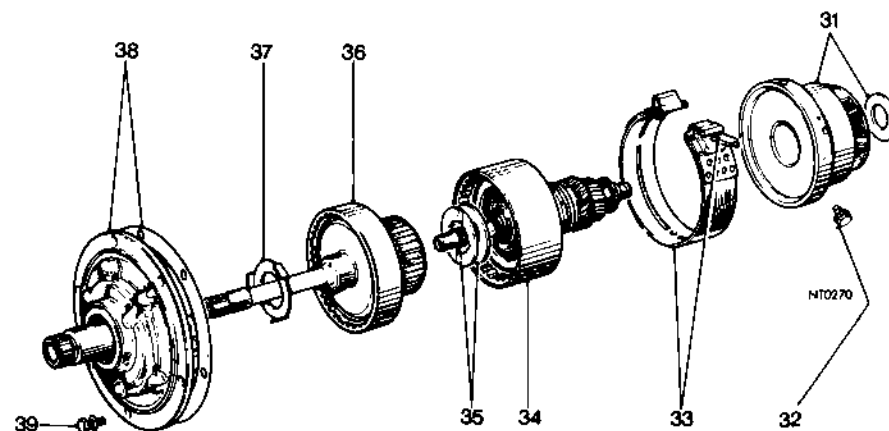
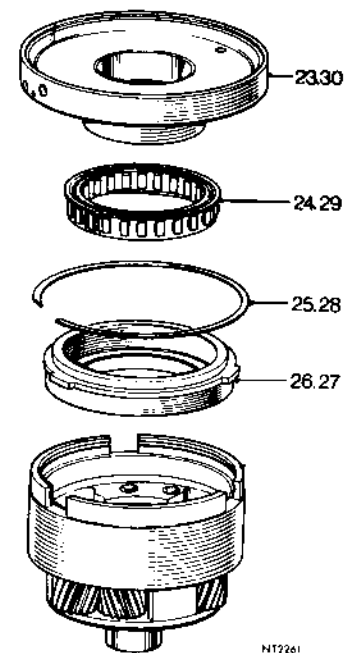

- 36 Refit the front clutch assembly.
- 37 Using petroleum jelly, stick the thrust washer to the pump assembly.
- 38 Refit the pump assembly and joint washer.
- 39 Fit and tighten the bolts.
- 40 Refit the oil tubes. (Note the 'O' ring on the pump suction tube.)
- 41 Refit the oil tube locating plate.
- 42 Fit and tighten the two bolts.
- 43 Carefully refit the valve block, ensuring that the oil tubes are not distorted.
- 44 Fit and tighten three bolts and washers.
- 45 Connect the downshift inner cable to the downshift cam.
- 46 Refit the oil tubes.
- 47 Replace the magnet and refit the oil pan and joint washer.
- 48 Fit and tighten 12 bolts.
- 49 Locate the torque converter housing in place.
- 50 Fit and tighten four bolts securing the torque converter housing.
- 51 Refit the switch. 44.15.15.
- 52 Refit the transmission unit. 44.20.01.

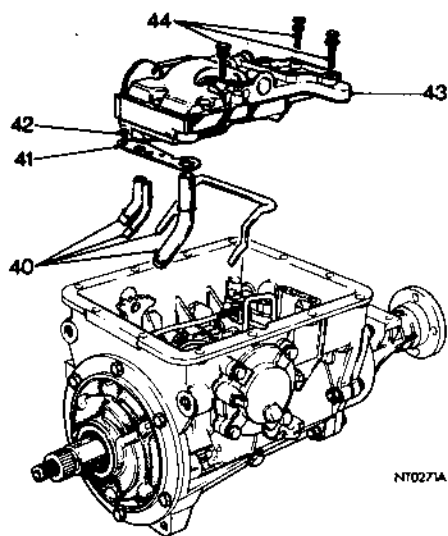

### DOWNSHIFT CABLE

Remove and refit 44.15.01  
Service tool: CBW 62

#### Removing

- 1 Drive the vehicle onto a ramp, select 'N', chock the wheels and open the bonnet.
- 2 Unscrew the locknut and remove the cable from the bracket.
- 3 Remove the split pin, washer and clevis pin.
- 4 Raise the ramp and remove the transmission sump pan. 44.24.04.
- 5 Disconnect the downshift inner cable from the cam.
- 6 Using tool no. CBW 62, remove the downshift outer cable from the gearbox casing.
- 7 Remove the downshift cable assembly.

#### Refitting

- 8 Clip the downshift outer cable into the gearbox casing.
- 9 Connect the inner cable to the downshift cam.
- 10 Refit the sump pan and lower the ramp.

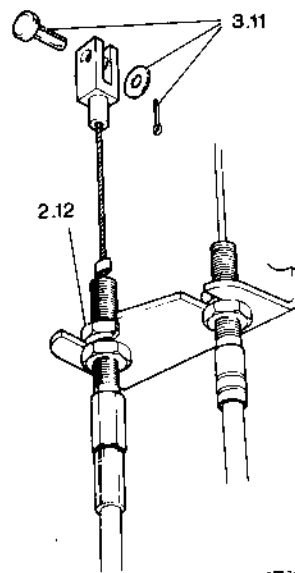
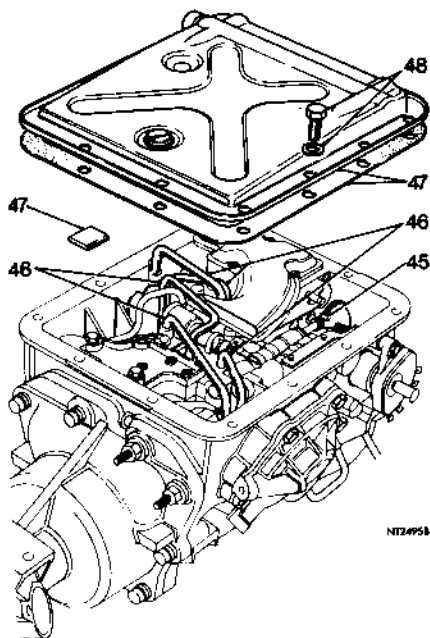

- 11 Refit the clevis pin, washer and split pin.
- 12 Refit the locknut and adjust the cable. 44.30.01.
- 13 Refill the unit with transmission fluid.

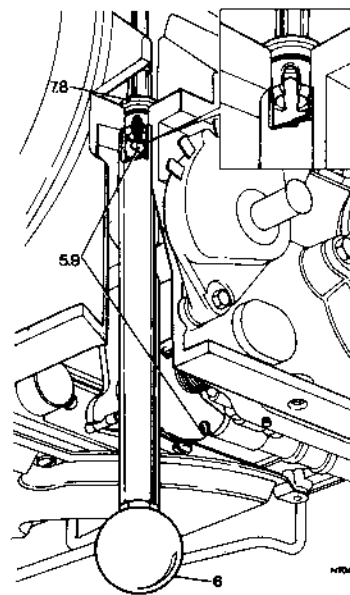

### HAND SELECTOR LEVER

Remove and refit 44.15.04

#### Removing

- 1 Remove the push button cap.
- 2 Remove the push button securing screw.
- 3 Remove the push button and spring.
- 4 Unscrew and remove the gear knob.
- 5 Remove the two screws securing the gear lever surround.

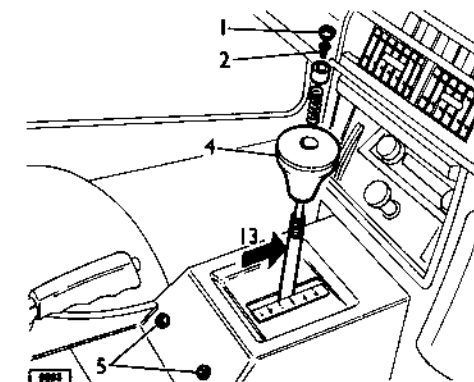

*continued*

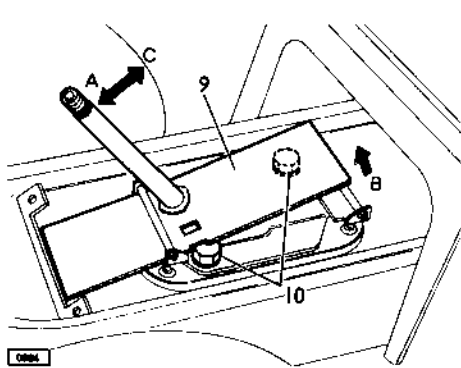
**HAND SELECTOR LEVER****Overhaul** 44.15.05

- 1 Remove the hand selector lever. 44.15.04.
- 2 Pull out the inner lever.
- 3 Clean, inspect and regrease the inner lever.
- 4 Refit the inner lever.
- 5 Refit the hand selector lever.

**HAND LEVER TURRET ASSEMBLY****Overhaul** 44.15.06

- 1 Jack up front of the vehicle and place on two axle stands.
- 2 Disconnect the clip securing the selector rod to the turret lever.
- 3 Disconnect the selector rod from the turret lever.
- 4 Remove the hand selector lever assembly. 44.15.04.
- 5 Remove the two screws securing the hand brake lever surround.
- 6 Carefully remove the hand brake surround over the hand brake lever.
- 7 With the centre glove box open, remove the two screws securing the glove box catch to the centre console.
- 8 Remove the glove box catch.
- 9 Remove the four screws and rear plate securing the centre console.

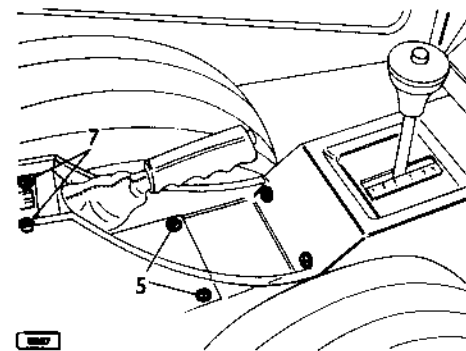

- 10 Unclip the illumination light harness wires from the console.
- 11 Remove the centre console.
- 12 Remove the screws securing the turret assembly to the transmission tunnel.
- 13 Lift out the turret assembly.
- 14 Remove the two nuts and bolts securing the quadrant to the turret.

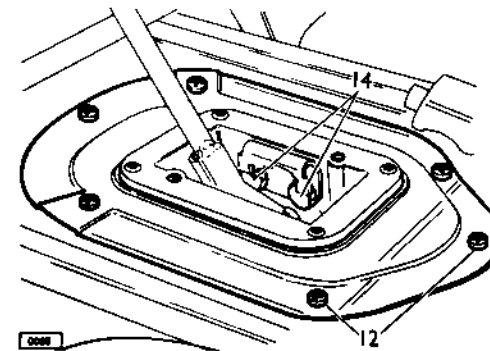

- 15 Remove the quadrant.
- 16 Remove the circlip and washer retaining the turret shaft in the tunnel.
- 17 Remove the turret shaft.
- 18 Clean and inspect all parts including the hand selector lever.
- 19 Grease all bearing surfaces.
- 20 Reverse 4-17.
- 21 Select 'P-Park' position on the lever.
- 22 Select 'P-Park' position on the gearbox selector lever.
- 23 Check/adjust the selector rod as necessary. 44.30.04.
- 24 Reconnect the selector rod to the turret lever.
- 25 Engage the securing clip.
- 26 Lower the vehicle.

**SELECTOR ROD****Remove and refit** 44.15.08**Removing**

- 1 Drive the vehicle onto a ramp, lock the selector lever in 'N' and apply the hand brake.
- 2 Raise the ramp.
- 3 Push the clips clear of the levers.
- 4 Remove the selector rod from the gearbox selector and hand lever.

**Refitting**

- 5 Slacken the selector rod locknut.
- 6 Ensure that the gearbox selector lever and the hand lever are both in position 'N'.
- 7 Fit the selector rod to the gearbox selector lever.
- 8 Fit the clip onto the selector lever.
- 9 Alter the length of the rod by adjusting the turn-buckle until the end of the rod can be located in the hand lever.
- 10 Tighten the locknut.
- 11 Push the clip onto the lever and secure the rod.
- 12 Lower the ramp.

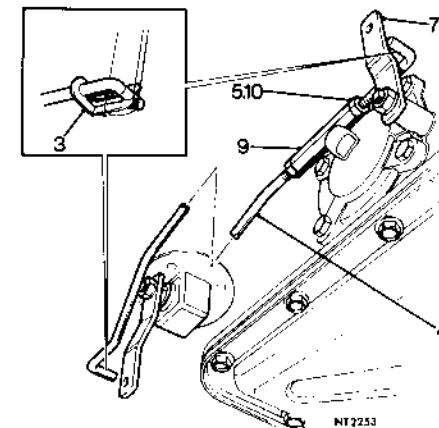

- 6 Disconnect the quadrant illumination light from the surround.
- 7 Remove the gear lever surround.
- 8 Disconnect the gear indication light from the socket.
- 9 Remove the steel cover by operating the gear lever to each extreme.
- 10 Remove the two bolts securing the roller assembly.
- 11 Remove the roller assembly.
- 12 Remove the two bolts securing the gear lever to the turret shaft and remove the lever.

**Refitting**

- 13 Reverse 1-12  
(To facilitate the refitting of the push button securing screw, pull out the inner lever and hold in position against the quadrant stop.)

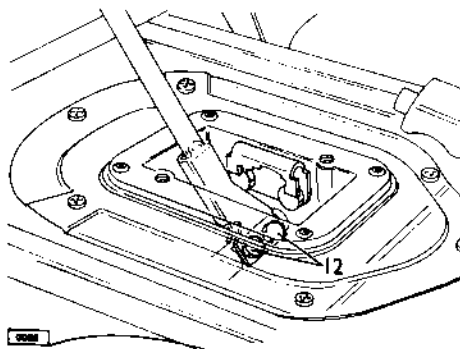



## GEARBOX SELECTOR LEVER

Remove and refit 44.15.09

### Removing

- 1 Drive the vehicle onto a ramp, select 'N' and apply the hand brake.
- 2 Raise the ramp.
- 3 Push the clip rearward.
- 4 Disconnect the selector rod from the lever.
- 5 Unscrew the nut and washer.
- 6 Remove the lever.

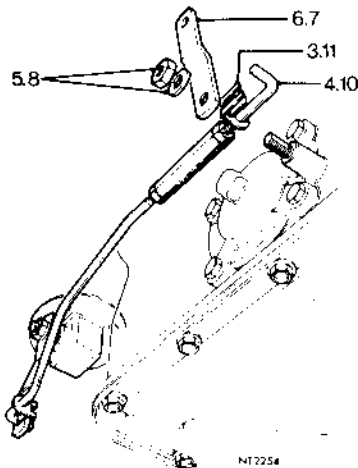

### Refitting

- 7 Fit the lever to the shaft.
- 8 Fit and tighten the nut and washer.
- 9 Move the selector into the neutral position.
- 10 Connect the selector rod to the lever.
- 11 Push the clip onto the lever and secure the rod.
- 12 Lower the ramp.

## STARTER INHIBITOR/REVERSE LAMP SWITCH

Remove and refit 44.15.15

### Removing

- 1 Drive the vehicle onto a ramp, chock the wheels and raise the ramp.
- 2 Remove the three bolts securing the heat shield to the transmission sump.
- 3 Remove the heat shield and spacers.
- 4 Disconnect the switch from the block connector on the wiring harness.
- 5 Remove the thread protector (if fitted).
- 6 Remove the bolt securing the switch to the transmission unit.
- 7 Remove the switch.

### Refitting

- 8 Reverse 1-7.

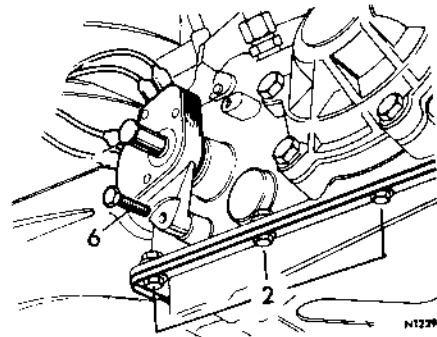

## TORQUE CONVERTER HOUSING

Remove and refit 44.17.01

Service tool: CBW 547A-50 – Torque Wrench.

### Removing

- 1 Remove the gearbox. 44.20.01
- 2 Unscrew the four bolts securing the torque converter housing to the transmission.
- 3 Remove the housing.

### Refitting

- 4 Place the torque converter housing in position.
- 5 Fit and tighten the four bolts using Service tool CBW 547A-50.
- 6 Refit the gearbox. 44.20.01.

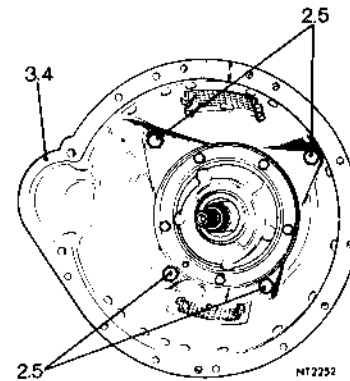

## TORQUE CONVERTER

Remove and refit 44.17.07

Service tool: CBW 547A-50

### Removing

- 1 Remove the transmission unit. 44.20.01.
- 2 Remove the torque converter from the transmission unit.

### Refitting

- 3 Relocate the torque converter in the transmission unit.
- 4 Refit the gearbox. 44.20.01.

## GEARBOX

Remove and refit 44.20.01

### Removing

- 1 Drive the vehicle onto a ramp, select 'N' and chock the wheels.
- 2 Remove the split pin, washer and clevis pin and undo the cable lock nut.
- 3 Release the downshift cable from the throttle linkage.
- 4 Raise the ramp.
- 5 Remove the exhaust front pipe. 30.10.09.
- 6 Disconnect the dipstick tube from the transmission sump and drain the fluid into a suitable receptacle.
- 7 Disconnect the selector lever from the selector shaft.
- 8 Disconnect the breather hose from the gearbox.
- 9 Disconnect the starter inhibitor/reverse light switch at the block connector on the wiring harness.
- 10 Disconnect the cooler pipes.
- 11 Remove the clamp and disconnect the speedometer cable.
- 12 Remove the propshaft bolts and disconnect the propshaft.
- 13 Remove the four bolts securing the torque converter to the engine drive plate.
- 14 Using a suitable jack under the engine sump, support the engine and gearbox assembly.
- 15 Remove the centre bolt and plate from the rear mounting.

*continued*

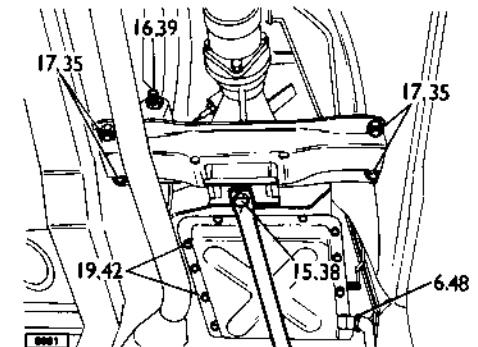

- 16 Remove the steady bar and disconnect the cable (if fitted).
- 17 Remove the four nuts securing the rear cross member.
- 18 Remove the cross member.
- 19 Remove the three bolts, heat shield and spacers.
- 20 Position the unit lift and support the gearbox.
- 21 Remove the four bolts securing the radiator lower mounting.
- 22 Detach the cooler pipes from the securing clips.
- 23 Detach the radiator from the upper mountings and withdraw forwards.
- 24 Remove the exhaust support bracket.

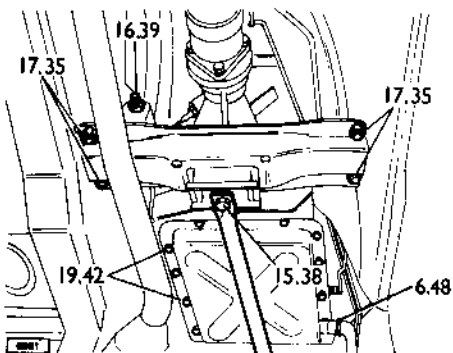

- 25 Lower the unit and remove all the bolts and nuts securing the bell housing and starter motor to the engine unit.
- 26 Remove the dipstick tube.
- 27 Remove the earth leads and all the harness securing clips.
- 28 Lower the gearbox rearwards on the unit lift.

#### Refitting

- 29 Raise the gearbox into position using the unit lift.
- 30 Fit and tighten the dowel bolt and nuts securing the bell housing to the engine.

- 31 Reposition the starter motor, earth leads, dipstick tube and harness clips to the converter housing.
- 32 Fit and tighten the remaining securing bolts.
- 33 Refit the exhaust bracket and tighten the fixing bolts.
- 34 Raise the engine and gearbox assembly into the mounting position.
- 35 Position the rear cross member and tighten the four securing bolts.
- 36 Remove the engine support jack and unit lift.
- 37 Position the rear mounting centre plate and steady bar (if fitted).
- 38 Tighten the rear mounting centre bolt.
- 39 Reconnect the steady cable (if fitted).
- 40 Fit and tighten the four bolts securing the torque converter to the engine drive plate.
- 41 Reconnect the propshaft and tighten the four bolts.
- 42 Fit the spacers, heat shield and securing bolts.
- 43 Reconnect and secure the speedo cable.
- 44 Reconnect the cooler pipes to the gearbox and tighten the union nuts.
- 45 Reconnect the starter inhibitor/reverse light switch at the block connector on the wiring harness.
- 46 Reconnect the breather pipe.
- 47 Reconnect the selector lever.
- 48 Reconnect and tighten the dipstick tube to the transmission sump.
- 49 Reposition the radiator and tighten the four bolts securing the lower mounting.
- 50 Clip the cooler pipes to the radiator.
- 51 Refit the exhaust front pipe.
- 52 Lower the ramp.
- 53 Reconnect the downshift cable to the throttle linkage.
- 54 Fill the gearbox with fluid. 44.24.02

## GEARBOX

### Overhaul

44.20.06

Service tools: CBW 60, CBW 33, CBW 34, CBW 62, CBW 547A-50, CBW 547A-50-2A, RG 421 or S 337, CBW 33.

- 1 Remove the transmission unit. 44.20.01.
- 2 Wash the exterior of the unit in clean petrol or paraffin, invert it and place on a bench cradle CBW 60.

### Dismantling

- 3 Unscrew the bolts securing the torque converter housing.
- 4 Remove the torque converter housing.
- 5 Unscrew 12 bolts.
- 6 Remove the oil pan, joint washer and magnet.
- 7 Pull out the oil tubes.
- 8 Release the downshift inner cable from the downshift cam.
- 9 Take out three bolts and washers.
- 10 Lift off the valve block.
- 11 Unscrew two bolts.
- 12 Remove the oil tube locating plate.
- 13 Pull out the oil tubes. (Note the 'O' ring on the pump suction tube.)

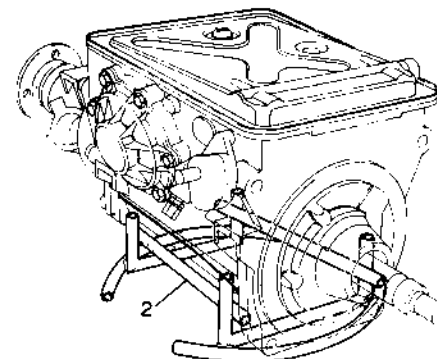

NT2564

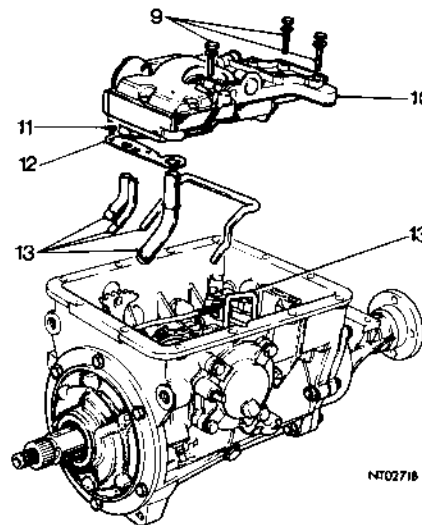

NT02716

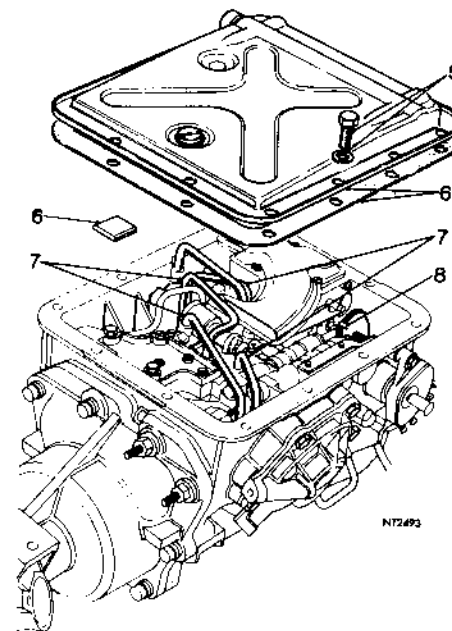

NT2493

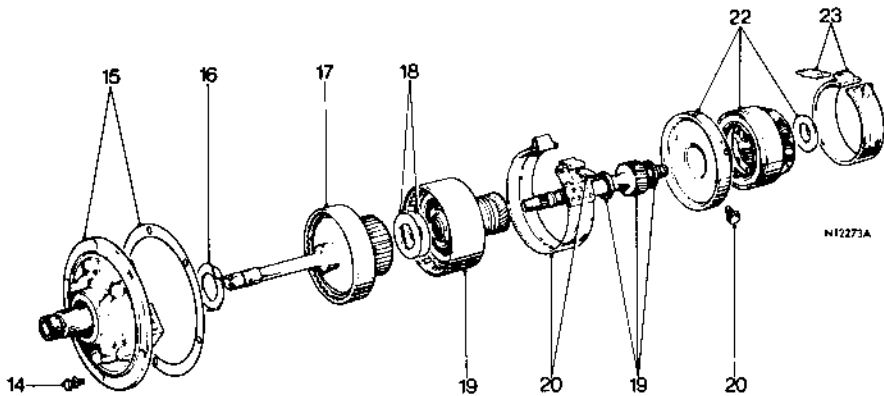

- 14 Take out five bolts.
- 15 Remove the pump and joint washer.
- 16 Remove the thrust washer.
- 17 Withdraw the front clutch.
- 18 Remove the thrust washers.
- 19 Withdraw the rear clutch and forward sun gear.
- 20 Squeeze together the ends of the front brake band and remove it together with the strut.
- 21 Unscrew the three bolts.
- 22 Withdraw the centre support/planet gear assembly.
- 23 Squeeze together the ends of the rear brake band, tilt and withdraw it together with the strut.

- 24 Using tool no. RG 421 or S 337 to hold the flange, unscrew the nut.
- 25 Withdraw the flange.
- 26 Unscrew the bolts.
- 27 Remove the rear extension and joint washer.
- 28 Remove the clamp tube.
- 29 Withdraw the speedometer drive gear.
- 30 Unscrew the counterweight.
- 31 Withdraw the governor assembly.
- 32 Withdraw the output shaft assembly and thrust washer.
- 33 Remove the oil tubes.
- 34 Unscrew the bolts.

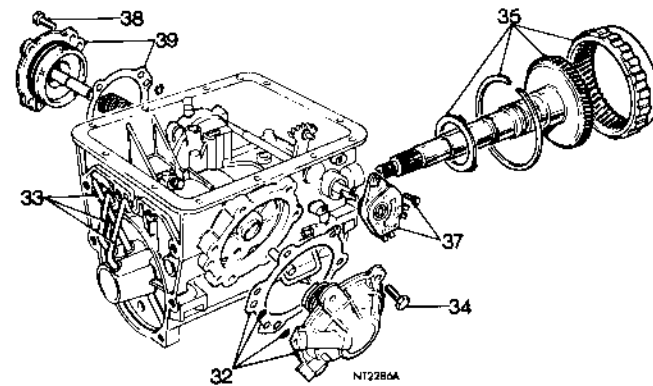
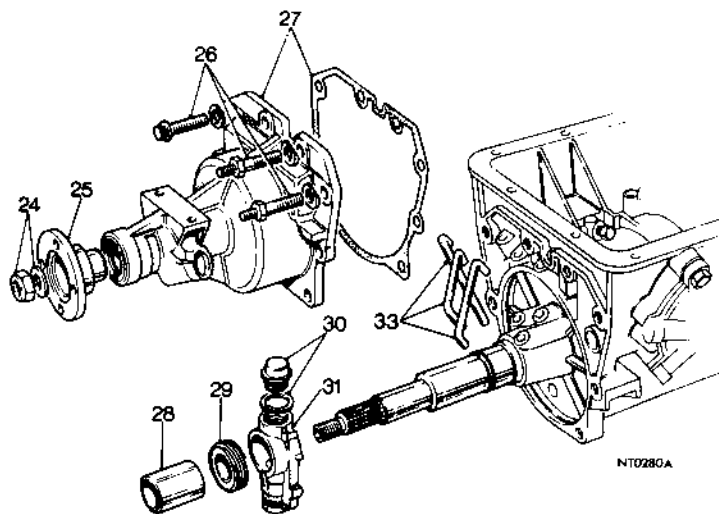

- 35 Remove the rear servo assembly, joint washer and 'O' rings.
- 36 Unscrew the nut and remove the selector lever.
- 37 Unscrew the bolt and remove the switch.
- 38 Unscrew the bolts.
- 39 Remove the front servo and joint washer.
- 40 Remove the spring clip.
- 41 Withdraw the pin.
- 42 Withdraw the cross-shaft and remove the 'O' ring.
- 43 Remove the detent lever, collar, washers and 'O' ring.
- 44 Remove the oil seal.
- 45 Unscrew two screws and remove the cam plate.
- 46 Remove the parking brake rod assembly.
- 47 Withdraw the parking brake pawl pivot pin.
- 48 Remove the parking brake pawl.
- 49 Remove the spring.
- 50 Remove the relay lever pivot pin.
- 51 Remove the relay lever.
- 52 Remove the torsion spring.
- 53 Using tool no. CBW 62, remove the downshift cable assembly.
- 54 Using tool no. CBW 62, remove the breather adaptor.

- 55 Unscrew the unions and remove the bridge pipe.
- 56 Unscrew the adaptor.
- 57 Unscrew the return valve.
- 58 Withdraw the rear servo lever pivot pin.
- 59 Remove the rear servo lever.
- 60 Unscrew the locknuts.
- 61 Unscrew the adjusting screws.
- 62 Unscrew the pressure take-off plug.

*continued*

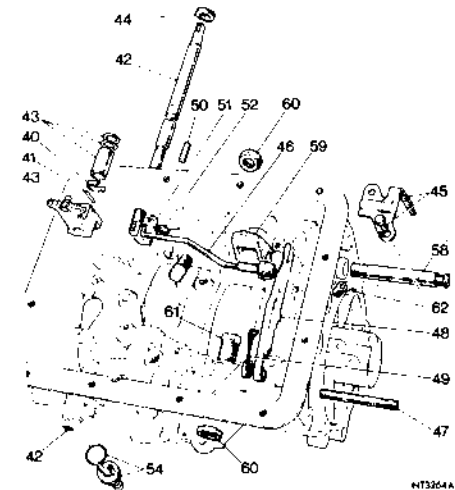

N13264A

**Reassembling**

- 63 Fit the pressure take-off plug.
- 64 Refit the adjusting screws.
- 65 Loosely refit the locknuts.
- 66 Replace the rear servo lever.
- 67 Refit the rear servo lever pivot pin.
- 68 Fit the oil return valve.
- 69 Fit the adaptor.
- 70 Refit the bridge pipe and tighten the unions.
- 71 Refit the breather adaptor.
- 72 Refit the downshift cable.
- 73 Replace the relay lever and torsion spring.
- 74 Refit the relay lever pivot pin.
- 75 Replace the parking brake pawl and spring.
- 76 Refit the parking brake pawl pivot pin.
- 77 Refit the parking brake rod.
- 78 Refit the cam plate, ensuring that the tag end locates in the groove in the rear servo lever pivot pin.
- 79 Fit and tighten the bolts.
- 80 Fit a new cross-shaft oil seal.
- 81 Locate the cross-shaft through the oil seal and fit the washers.
- 82 Fit the collar and detent lever and push the cross-shaft fully home.
- 83 Refit the pin.
- 84 Refit the clip.
- 85 Refit the 'O' ring.
- 86 Refit the front servo and joint washer.
- 87 Fit and tighten the bolts.
- 88 Refit the switch and secure with the bolt.
- 89 Refit the selector lever and secure with the nut.

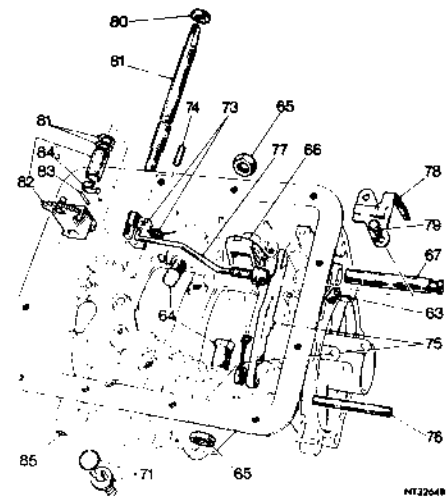

NT2264B

- 90 Refit the rear servo assembly, joint washer and 'O' rings, retaining them in position using petroleum jelly.
- 91 Fit and tighten the bolts.
- 92 Refit the oil tubes, ensuring that they are correctly located.
- 93 Locate the thrust washer on the end wall of the casing, using petroleum jelly.
- 94 Carefully refit the output shaft assembly.
- 95 Refit the governor assembly.
- 96 Fit and tighten the counterweight.
- 97 Refit the speedometer drive gear.
- 98 Refit the clamp tube.
- 99 Refit the rear extension housing and joint washer.

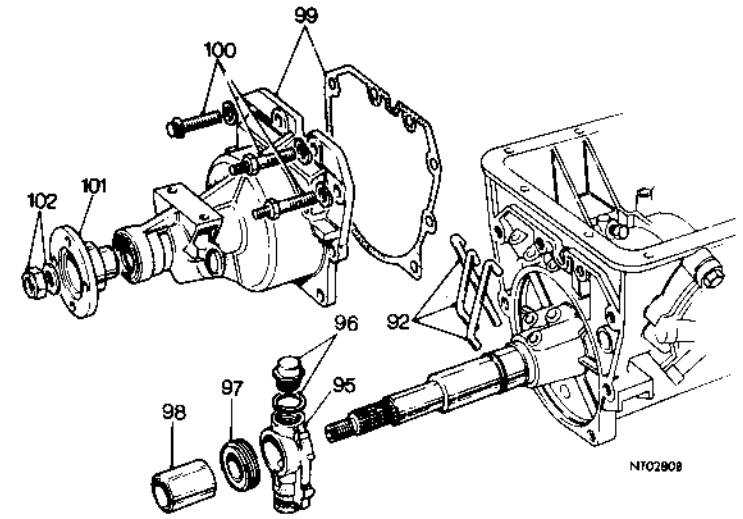

NT0280B

- 100 Fit and tighten the bolts.
- 101 Tap the drive flange into position.
- 102 Fit the washer and nut; using tool no. RG 421 or S 337 to hold the flange, tighten the nut to the correct torque.
- 103 Squeeze together the ends of the rear brake band, tilt and locate it in position.
- 104 Refit the rear brake band strut.
- 105 Using petroleum jelly, locate the thrust race on the rear drum spigot.
- 106 Refit the centre support/planet gear assembly, ensuring the oil and locating holes align with those in the casing.
- 107 Fit and tighten the three bolts.

- 108 Squeeze together the ends of the front brake band and fit it in position together with the strut.
- 109 Refit the rear clutch and forward sun gear assembly.
- 110 Using petroleum jelly, stick the thrust washers to the rear clutch assembly (phosphor bronze towards the front clutch).
- 111 Refit the front clutch assembly.
- 112 Using petroleum jelly, stick the thrust washer to the pump assembly.
- 113 Refit the pump assembly and joint washer.
- 114 Fit and tighten the bolts.

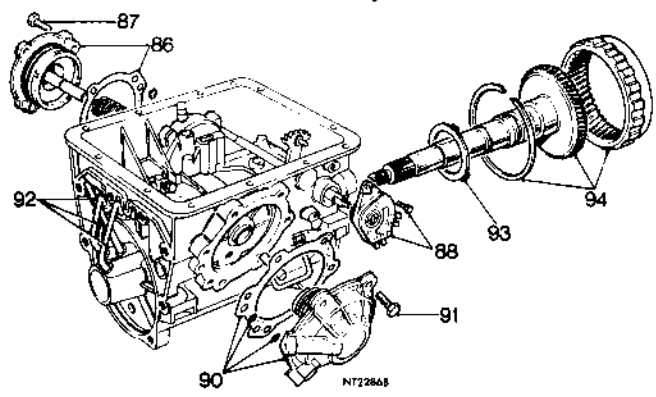

NT2286B

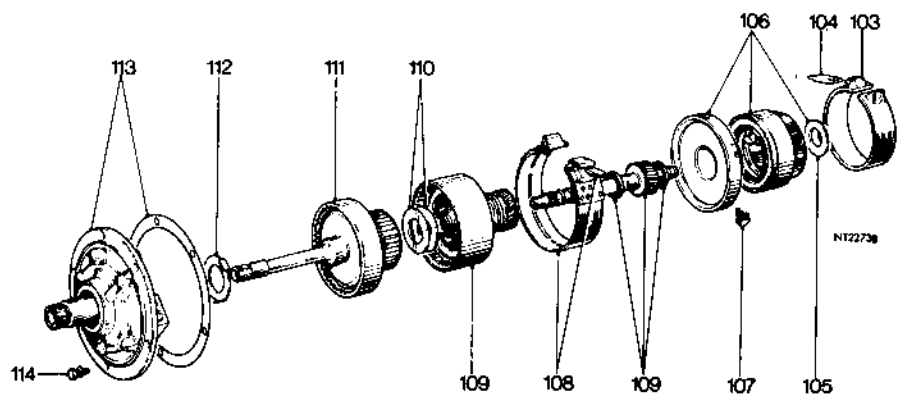

NT2273B

- 115 Using tool no. CBW 33, check the gear train end-float, and if necessary, adjust the selective use of the thrust washer fitted between the pump and the front clutch.  
Recommended end-float 0.25 mm to 0.75 mm (0.010 to 0.030 in).

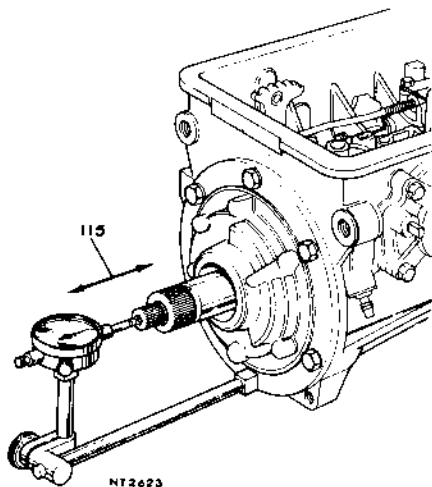

- 116 Adjust the front band as follows:  
a Slacken the adjusting screw and locknut.  
b Tighten the adjusting screw to 0.7 kgf m (5 lbf ft) and back off three-quarters of a turn.  
c Tighten the locknut.

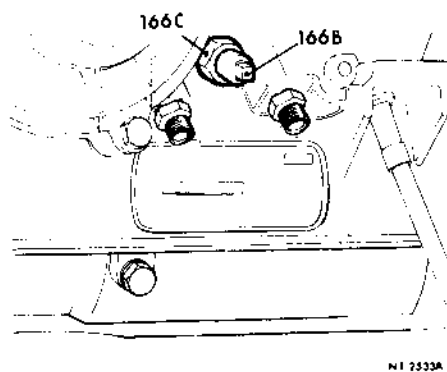

- 117 Adjust the rear band as follows:  
a Slacken the adjusting screw and locknut.  
b Tighten the adjusting screw to 0.7 kgf m (5 lbf ft) and back off three-quarters of a turn.  
c Tighten the locknut.

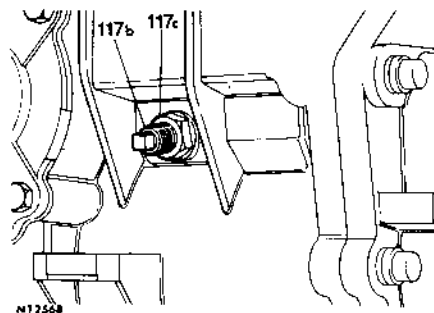

- 118 Refit the oil tubes. (Note the 'O' ring on the pump suction tube).  
119 Refit the oil tube locating plate.  
120 Fit and tighten the two bolts.  
121 Carefully refit the valve block, ensuring that the oil tubes are not distorted.  
122 Fit and tighten the three bolts and washers.  
123 Connect the downshift inner cable to the downshift cam.  
124 Refit the oil tubes.  
125 Replace the magnet and refit the oil pan and joint washer.  
126 Fit and tighten 12 bolts.  
127 Locate the torque converter housing in place.  
128 Fit and tighten four bolts securing the torque converter housing.  
129 Refit the transmission unit.

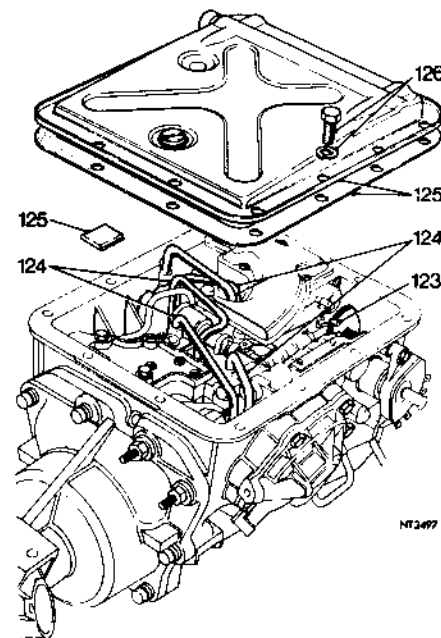
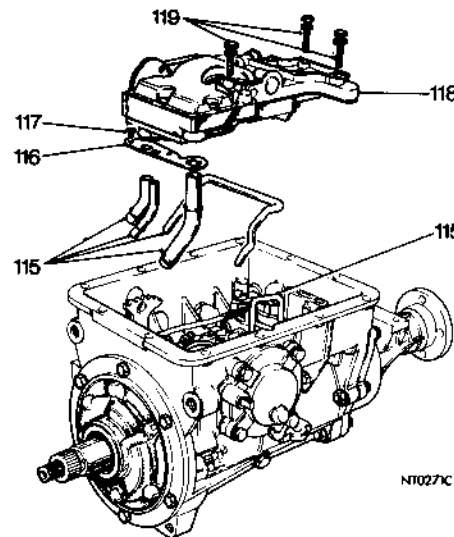

## REAR EXTENSION HOUSING

Remove and refit 44.20.15  
Service tool: RG 421 or 5337

### Removing

- 1 Drive the vehicle onto a ramp, select 'N', chock the road wheels and raise the ramp.
- 2 By removing one of the bolts and slackening the other, swing the prop guard clear of the propshaft.
- 3 Remove the four nuts and bolts securing the propshaft to the drive flange and disconnect the propshaft.

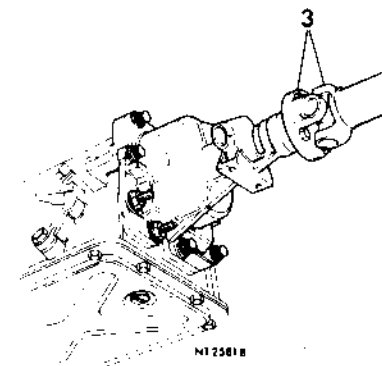

- 4 Using Service tool RG 421 or 5337 remove the nut securing the drive flange.
- 5 Remove the drive flange.
- 6 Using a ramp jack and suitable wooden block, support the transmission unit under the sump pan.
- 7 Remove the centre gearbox mounting bolt and plate.
- 8 Remove the steady bar and disconnect the cable (if fitted).
- 9 Remove the four nuts securing the cross member.
- 10 By raising the LH captive bolts, release the cross member and remove.

*continued*

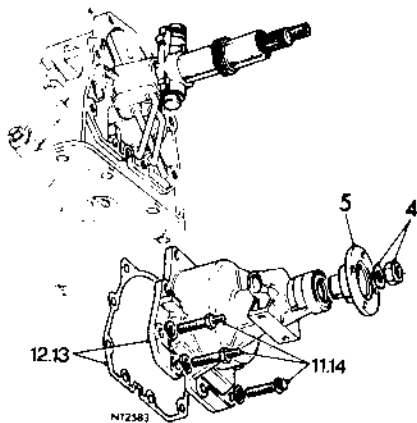

- 11 Remove the clamp bolt and clamp and disconnect the speedo cable.
- 12 Remove the nut and bolt securing the exhaust pipe to the mounting bracket.
- 13 Remove the two nuts securing the bracket to the rear extension housing and remove the bracket and spacers.
- 14 Remove the eight bolts securing the rear extension to the transmission case.
- 15 Withdraw the rear extension housing.

**Refitting**

- 16 Reverse 1-15.

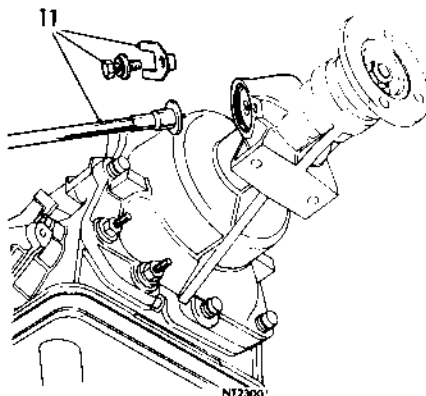
**REAR OIL SEAL**

Remove and renew

44.20.18

**Removing**

- 1 Drive vehicle onto a ramp, select 'P', chock the road wheels and raise the ramp.
- 2 Remove the four nuts and bolts securing the propshaft to the drive flange.
- 3 Disconnect the propshaft.
- 4 Remove the nut securing the drive flange.
- 5 Remove the drive flange.
- 6 Prise out the oil seal.
- 7 Clean the area surrounding the oil seal.

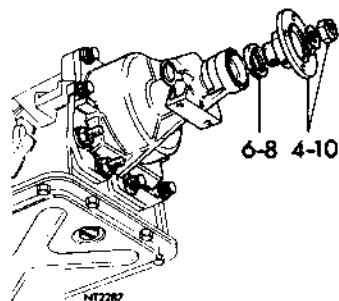
**Renewing**

- 8 Carefully fit the new oil seal into the rear extension.
- 9 Lubricate the lip of the oil seal.
- 10 Refit the drive flange and securing nut.
- 11 Reconnect the propshaft.
- 12 Refit and tighten the prop bolts and nuts.
- 13 Lower the ramp.

**GOVERNOR**

Remove and refit

44.22.01

**Removing**

- 1 Remove the rear flange, rear extension and speedometer drive gear. 44.38.07.
- 2 Unscrew the counterweight.
- 3 Note the position and withdraw the governor assembly.

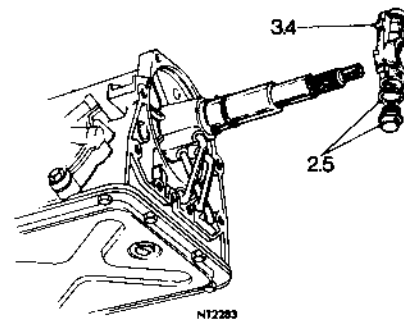
**Refitting**

- 4 Slide the governor assembly into the noted position.
- 5 Locate and secure the counterweight.
- 6 Refit the speedometer drive gear, rear extension and drive flange. 44.38.07.

**GOVERNOR**

Overhaul

44.22.04

**Dismantling**

- 1 Pull off the retainer.
- 2 Withdraw the weight.
- 3 Withdraw the stem.
- 4 Remove the spring.
- 5 Withdraw the valve.

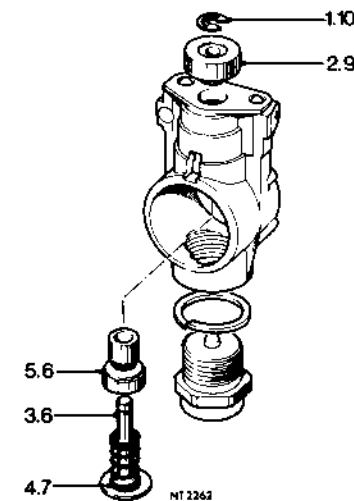
**Reassembling**

- 6 Insert the valve.
- 7 Refit the spring onto the stem.
- 8 Refit the stem and spring.
- 9 Refit the weight.
- 10 Refit the retainer.

## DIPSTICK/FILLER TUBE

Remove and refit

44.24.01

### Removing

- 1 Drive the vehicle onto a ramp, select 'P'-'Park', apply the hand brake and open the bonnet.
- 2 Withdraw the dipstick.
- 3 Raise the ramp.
- 4 Release the filler tube from the engine/transmission flange.
- 5 Unscrew the union nut from the sump pan, and release the filler pipe from the sump.
- 6 Withdraw the filler tube from below the vehicle.

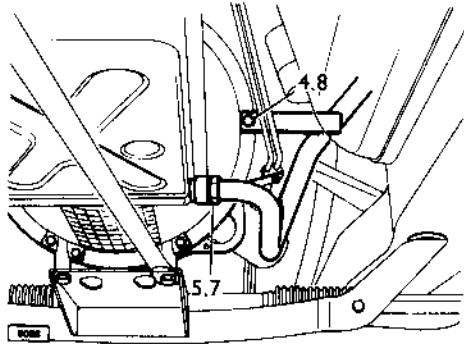

### Refitting

- 7 Manoeuvre the filler tube into position and secure it to the sump pan with the union nut.
- 8 Secure the filler tube to the engine/transmission flange.
- 9 Lower the ramp.
- 10 Refill the unit with fluid. 44.24.02.

## TRANSMISSION FLUID

Drain and refill

44.24.02

### Draining

- 1 Drive the vehicle onto a ramp, select 'P'-'PARK' and apply the hand brake.
- 2 Raise the ramp.
- 3 Place a tray under the drain plug.
- 4 Unscrew the plug.
- 5 Drain the fluid into the tray.  
**NOTE:** It is not possible to drain the torque converter.

### Filling

If the sump has been drained it will be necessary to replenish the transmission unit until the fluid level is no higher than the 'cold high' mark 'C' (third mark down from top).

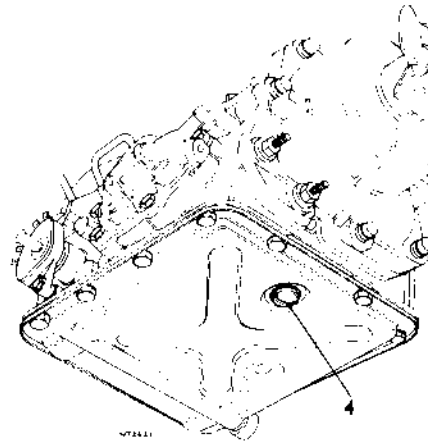

Check the level (hot) as follows:

- 6 Drive the vehicle for approximately 30 km (20 miles) until the transmission unit has reached its normal operating temperature.
- 7 Park the vehicle on level ground, apply the hand brake and select 'P'-'PARK'. Leave the engine running at idle speed.
- 8 Raise the bonnet and wipe clean around the dipstick/filler orifice.
- 9 Withdraw the dipstick and wipe it clean, using clean paper or a non-fluffy cloth.
- 10 Push the dipstick home and again withdraw it for reading. The fluid level should be at the top mark 'A' ('Hot high').  
**DO NOT OVERFILL THE TRANSMISSION.**

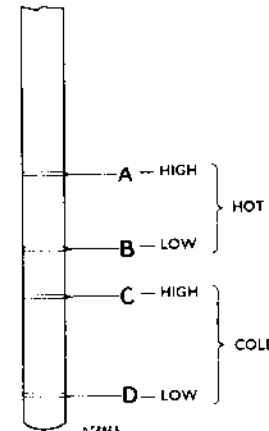

## TRANSMISSION SUMP

Remove and refit

44.24.04

### Removing

- 1 Unscrew the filler pipe union and drain the transmission unit.
- 2 Remove the bolts securing the heat shield.
- 3 Remove the heat shield spacers.

- 4 Remove the steady bar (if fitted).
- 5 Unscrew the bolts securing the sump.
- 6 Remove the sump and joint washer.

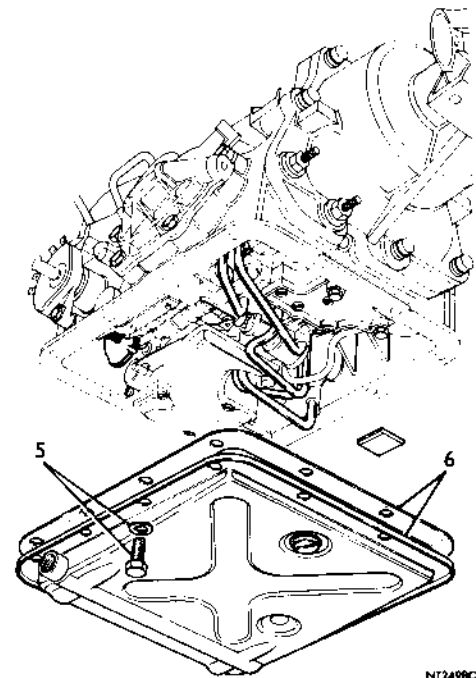
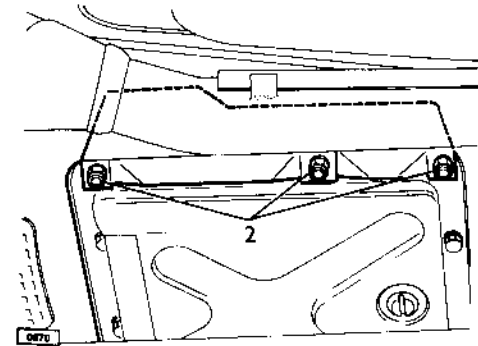

### Refitting

- 7 Reverse 1-6.
- 8 Fill the transmission unit with fluid. 44.24.02.

**OIL/FLUID FILTER**

Remove and refit 44.24.07

**Removing**

- 1 Remove the transmission sump. 44.24.04.
- 2 Remove the four screws securing the filter in position.
- 3 Remove the filter.

**Refitting**

- 4 Reverse 1-3.

**OIL/FLUID COOLER**

Remove and refit 44.24.10

**Removing**

- 1 Drive the vehicle onto a ramp, select 'P'-'Park', chock the road wheels and raise the ramp.
- 2 Detach the cooler pipes from the securing clip beneath the radiator.
- 3 Undo the cooler pipe union nuts.
- 4 Disconnect the cooler pipes.
- 5 Remove the two bolts securing the cooler to the body.
- 6 Remove the cooler.

**Refitting**

- 7 Reverse 1-6
- 8 Check/top up the transmission fluid.

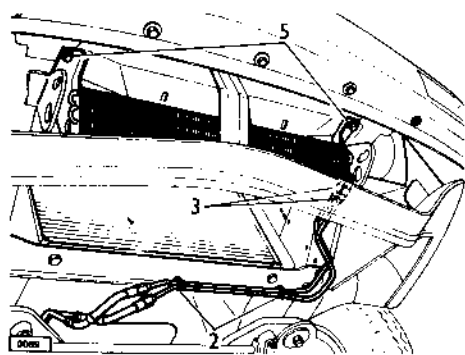

**DOWNSHIFT CABLE**

Initial setting 44.30.01

- 1 Check that the carburetter slow running and fast idle settings are satisfactory.
- 2 Slacken the locknut.
- 3 Adjust the outer cable in the bracket until the crimped stop is 1.5 mm (1/16 in) from the end of the outer cable ferrule.
- 4 Tighten the locknut.
- 5 Road test the vehicle and check the gear shift speeds.

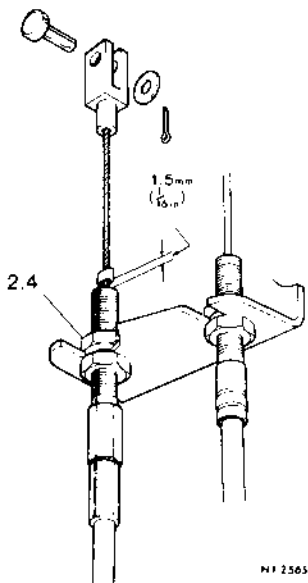

**DOWNSHIFT CABLE**

Adjust 44.30.02

- 1 Drive the vehicle onto a ramp, apply the hand brake and chock the wheels.
- 2 Start the engine, select 'D' and adjust the idling speed to 750 rev/min. Stop the engine.
- 3 Slacken the locknut.
- 4 Adjust the outer cable to 1.5 mm (1/16 in) from the stop. 44.20.01 (para. 3).
- 5 Remove the sump pan. 44.24.04.

- 6 Check that the downshift cam is in the idling position.
- 7 With the aid of an assistant in the driving seat, fully open the throttle and check that the downshift cam is in the kick-down position.
- 8 If necessary, adjust the outer cable until the idling and kick-down positions can be correctly obtained on the downshift cam. Tighten the locknut.
- 9 Refit the sump. 44.24.04.

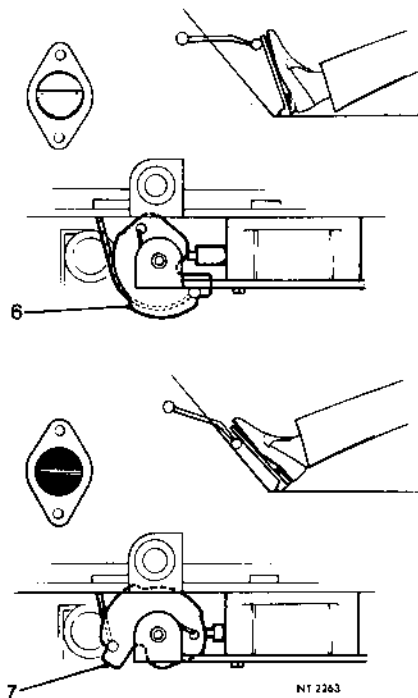

**DOWNSHIFT CABLE**

Pressure check 44.30.03

Service tools: CBW 1A or B and CBW 1B-2

- 1 Start and run the engine until the transmission reaches its normal operating temperature.
- 2 Drive the vehicle onto a ramp and check that the engine idling speed is approximately 750 rev/min. Stop the engine.

- 3 Raise the ramp.
- 4 Remove the plug.
- 5 Connect the pressure gauge to the transmission unit.
- 6 Lower the ramp, chock the wheels and apply the hand brake and foot brake.
- 7 Start the engine and select 'D'.

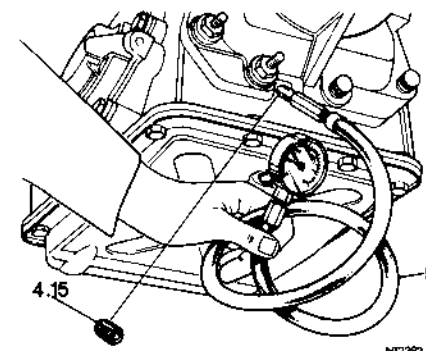

- 8 With the engine idling at 750 rev/min, note the pressure gauge reading which should be 4.2 to 5.3 kgf/cm<sup>2</sup> (60 to 75 lbf/in<sup>2</sup>).
- 9 Increase the engine speed to 1,000 rev/min and note the pressure increase which should be 1.0 to 1.4 kgf/cm<sup>2</sup> (15 to 20 lbf/in<sup>2</sup>).
- 10 Stop the engine.
- 11 If the pressure increase is less than 1.0 kgf/cm<sup>2</sup> (15 lbf/in<sup>2</sup>), increase the effective length of the outer cable. If the pressure increase is more than 1.4 kgf/cm<sup>2</sup> (20 lbf/in<sup>2</sup>), decrease the effective length of the outer cable.
- 12 Repeat operations 7 to 11 until the pressure increase is correct.
- 13 Raise the ramp.
- 14 Disconnect the pressure gauge.
- 15 Refit the plug.
- 16 Lower the ramp.



## SELECTOR ROD

Adjust 44.30.04

- 1 Drive the vehicle onto a ramp, lock the selector lever in 'N' and apply the hand brake.
- 2 Raise the ramp.
- 3 Slacken the locknut.
- 4 Push the clip off the hand lever.
- 5 Disconnect the selector rod and check that the gearbox selector lever is in the neutral position.
- 6 Alter the length of the selector rod by adjusting the turnbuckle until the end of the rod can be located in the hand lever.
- 7 Tighten the locknut.
- 8 Push the clip onto the lever and secure the rod.
- 9 Lower the ramp.

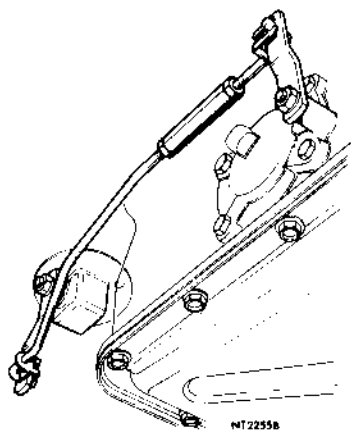

## FRONT BRAKE BAND

Adjust 44.30.07

Service tools: 18G 307

- 1 Drive the vehicle onto a ramp, select P - 'Park', apply the hand brake and raise the ramp.
- 2 Slacken the locknut.
- 3 Tighten the adjusting screw to 0.41 kgf m (36 lbf in) and back off three-quarters of a turn.
- 4 Tighten the locknut to 3.1 kgf m (22 lbf ft).
- 5 Lower the ramp.

## REAR BRAKE BAND

Adjust 44.30.10

Service tools: 18G 307

- 1 Drive the vehicle onto a ramp, select P - 'Park', apply the handbrake and raise the ramp.
- 2 Slacken the locknut.
- 3 Tighten the adjusting screw to 0.41 kgf m (36 lbf in) and back off three-quarters of a turn.
- 4 Tighten the locknut to 3.1 kgf m (22 lbf ft).
- 5 Lower the ramp.

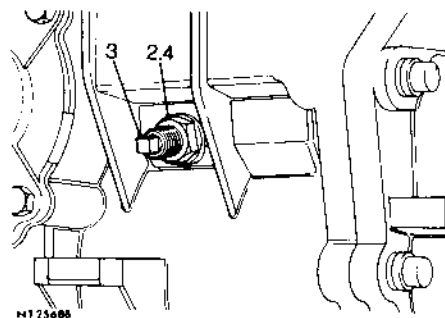

## STALL TEST 44.30.13

The function of a stall test is to determine that the torque converter and gearbox are operating satisfactorily.

- 1 Check the condition of the engine. An engine which is not developing full power will affect the stall test readings.
- 2 Allow the engine and transmission to reach correct working temperatures.

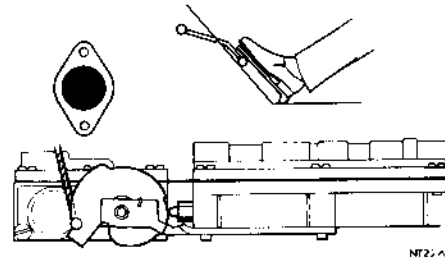

- 3 Check the wheels and apply the hand brake and foot brake.

- 4 Select '1' or 'R' and depress the throttle to the 'kick-down' position. Note the reading on the tachometer which should be 2,200 rev/min. If the reading is below 1,400 rev/min, suspect the converter for stator slip. If the reading is down to 1,600 rev/min, the engine is not developing full power. If the reading is in excess of 2,400 rev/min, suspect the gearbox for brake band or clutch slip.

NOTE: Do not carry out a stall test for a longer period than 10 seconds, otherwise the transmission will become overheated.

## ROAD TEST 44.30.17

Throughout the road test procedure the term 'full throttle' is equivalent to approximately seven-eighths of the available pedal movement and 'kick-down' is equivalent to the full movement.

### Procedure

- 1 Check that the starter motor will operate only with the selector lever in 'PARK' or 'N' and that the reverse lights operate only in 'R'.
- 2 Apply the hand brake and with the engine idling select 'N-D', 'N-2', 'N-R'. Engagement should be positive. A cushioned 'thump' under fast idling conditions is normal.
- 3 With the transmission at normal running temperatures, select 'D', release the brakes and accelerate with minimum throttle. Check the 1-2 and 2-3 shift speeds and the quality of change.
- 4 Stop the vehicle, select 'D' and re-start using 'full throttle'. Check 1-2 and 2-3 shift speeds and the quality of change.
- 5 At 40 m.p.h. (65 km/h) apply 'full throttle'. The vehicle should accelerate in third gear and should not downshift to second.
- 6 At a maximum speed of 56 m.p.h. (90 km/h) 'kick-down' fully. The transmission should downshift to second gear.

- 7 At a maximum speed of 35 m.p.h. (56 km/h) 'kick-down' fully. The transmission should downshift to first gear.

- 8 Stop the vehicle, select 'D' and re-start using 'kick-down'. Check the 1-2 and 2-3 shift speeds.

- 9 At 35 m.p.h. (56 km/h) select 2 and release the throttle. Check the 3-2 downshift.

- 10 At 30 m.p.h. (50 km/h) select 1 and release the throttle. Check the 2-1 downshift.

continued

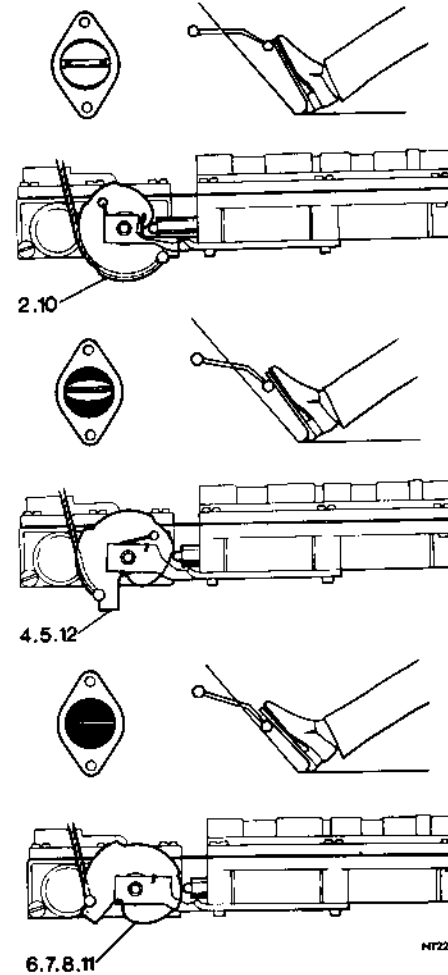

ROAD TEST – FAULT DIAGNOSIS CHART

NOTE: The numbers indicate the recommended sequence of investigation

- 11 With 1 still engaged, stop the vehicle and using 'kick-down' accelerate to over 40 m.p.h. (65 km/h). Check for 'slip', 'squawk', and the absence of upshifts.
- 12 Stop the vehicle and select 'R'. Reverse using 'full throttle' if possible. Check for 'slip' and 'squawk'.
- 13 Stop the vehicle on a gradient. Apply the hand brake and select 'P'-'PARK'. Release the hand brake and check the parking pawl hold. Check that the selector lever is held firmly in the gate in 'P'.

CONVERTER DIAGNOSIS

Inability to start on steep gradients, combined with poor acceleration from the rest and low stall speed (1,400 rev/min) indicates that the converter stator uni-directional clutch is slipping. This condition permits the stator to rotate in an opposite direction to the impeller and turbine, and torque multiplication cannot occur.

Poor acceleration in third gear above 30 m.p.h. (50 km/h) and reduced maximum speed, indicates that the stator uni-directional clutch has seized. The stator will not rotate with the turbine and impeller and the 'fluid flywheel' phase cannot occur. This condition will also be indicated by excessive overheating of the transmission although the stall speed will be correct.

Diagnosis	Engagement of 1, 2, D or R	Take off	Upshifts	Upshift Quality	Downshifts	Downshift Quality
SYMPTOM	Bumpy Delayed None	Slip Squawk No neutral Seizure reverse None reverse None forward	No 1-2 No 2-3 Above normal speed Below normal speed	Slip 1-2 Slip 2-3 Rough 1-2 Rough 2-3 Seizure 1-2 Seizure 2-3	No 3-2 Involuntary 3-2 Above normal speed Below normal speed	Rough 3-2 Rough 2-1 Slip 3-2 Slip 2-1
ADJUSTMENT FAULTS	Fluid level insufficient Downshift cable incorrectly assembled or adjusted Manual linkage incorrectly assembled or adjusted Incorrect engine idling speed Incorrect front band adjustment Incorrect rear band adjustment	1 2 2 1 2	1 1 2	1 1 2 2 3 3 4 4 2 2 1	1 1 1 1 1 1 1 1 1	1 1 1 1 1 1 1
HYDRAULIC CONTROL FAULTS	Oil tubes incorrectly installed, missing or leaking Sealing ring missing or broken Valve block screws missing or loose Primary regulator valve sticking Throttle valve sticking Modulator valve sticking Governor valve sticking, leaking or incorrectly assembled Orifice control valve sticking 1-2 shift valve sticking 2-3 shift valve sticking 2-3 shift valve plunger sticking Converter 'out' check valve sticking or missing Check valve sticking or missing	4 7 5 3 4 4 13 8	7 3 2 3 3 3 3 4 4 4 4	8 9 10 6 7 3 4 4 3 4 4 4	8 9 10 6 7 8 5 6 6 4 3 2 3 3	2 6 7 8 4 5 3 2 3 2 7 8 3 3
MECHANICAL FAULTS	Front clutch slipping Front clutch seized or plates distorted Rear clutch slipping Rear clutch seized or plates distorted Front band slipping due to faulty servo or worn band Rear band slipping due to faulty servo or worn band Uni-directional clutch slipping or incorrectly installed Uni-directional clutch seized Input shaft broken Front pump drive tangs on converter hub broken Front pump worn Converter blading and/or uni-directional clutch failed	6 7 11 7 12 10	4 2 2 9 8 5	4 2 6 5 5 8 7 8 9 10	9 5 5 6 7 8 3 4	2 9 6 7 2 8 1 1

## PUMP

Remove and refit 44.32.01

Service tools: CBW 60, CBW 547A-50

### Removing

- 1 Remove the transmission unit. 44.20.01.
- 2 Wash the exterior of the unit in clean petrol or paraffin, invert it and place on a bench cradle CBW 60. Remove the switch. 44.15.15.
- 3 Unscrew the bolts.
- 4 Remove the torque converter housing.
- 5 Unscrew 12 bolts.
- 6 Remove the oil pan, joint washer and magnet.
- 7 Pull out the oil tubes.
- 8 Release the inner downshift cable from downshift cam.
- 9 Take out three bolts and washers.
- 10 Lift off the valve block.
- 11 Unscrew two bolts.
- 12 Remove the oil tube locating plate.
- 13 Pull out the oil tubes. (Note the 'O' ring on the pump suction tube.)
- 14 Take out five bolts.
- 15 Remove the pump and joint washer.
- 16 Remove the thrust washer.

### Refitting

- 17 Using petroleum jelly, stick the thrust washer to the pump assembly.
- 18 Refit the pump assembly and joint washer.
- 19 Fit and tighten the bolts.
- 20 Refit the oil tubes. (Note the 'O' ring on the pump suction tube.)
- 21 Refit the oil tube locating plate.
- 22 Fit and tighten the two bolts.
- 23 Carefully refit the valve block, ensuring that the oil tubes are not distorted.

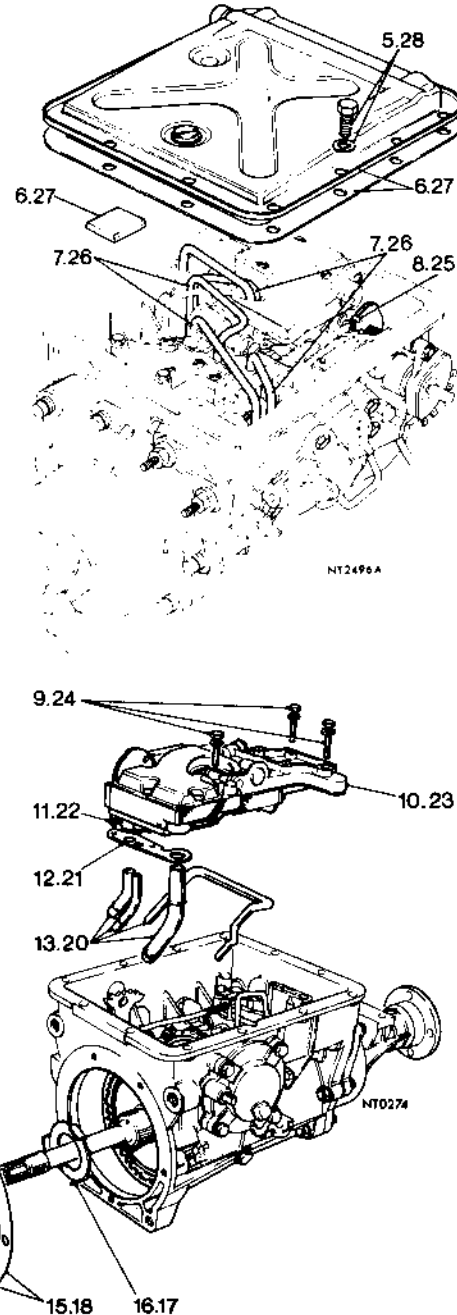

- 24 Fit and tighten the three bolts and washers.
- 25 Connect the downshift inner cable to the downshift cam.
- 26 Refit the oil tubes.
- 27 Replace the magnet and refit the oil pan and joint washer.
- 28 Fit and tighten 12 bolts.
- 29 Locate the torque converter housing in place.
- 30 Fit and tighten four bolts.
- 31 Refit the switch. 44.15.15.
- 32 Refit the transmission unit.

## PUMP

Overhaul 44.32.04

Service tool: CBW 547A-50

- 1 Remove the pump. 44.32.01.

### Dismantling

- 2 Unscrew the bolts.
- 3 Take out the locating screw.
- 4 Separate the stator support from the pump body assembly.
- 5 Mark the outside faces of the gears to facilitate correct assembly.
- 6 Remove the gears.
- 7 Remove the 'O' ring.
- 8 Extract the seal.

### Reassembling

- 9 Renew the seal.
- 10 Refit the 'O' ring.
- 11 Fit the gears into the pump body.
- 12 Lightly lubricate the gears and the 'O' ring.
- 13 Refit the stator support.
- 14 Fit and tighten the locating screw and lock washer.
- 15 Fit and tighten the bolts and lock washers.
- 16 Refit the front pump. 44.32.01.

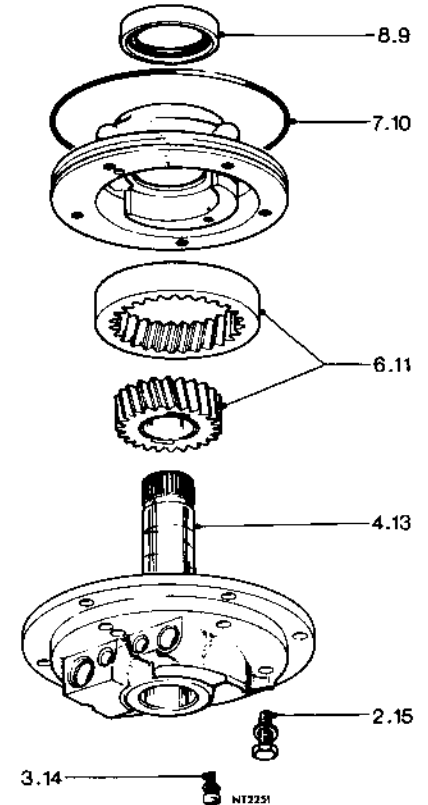

**FRONT SERVO**

Remove and refit 44.34.07

Service tool: CBW 547A-50

**Removing**

- 1 Drive the vehicle onto a ramp, select 'N' and apply the hand brake.
- 2 Disconnect the gearbox selector lever.
- 3 Take out the four bolts.
- 4 Withdraw the front servo assembly, spring and joint washer.

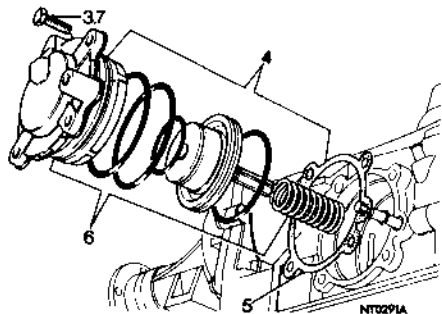
**Refitting**

- 5 Locate the joint washer onto the servo body flange.
- 6 Refit the servo and spring.
- 7 Fit the tighten the bolts using CBW 547A-50.

**FRONT SERVO**

Overhaul 44.34.10

- 1 Remove the front servo. 44.34.07

**Dismantling**

- 2 Remove the spring.
- 3 Withdraw the piston using air pressure.
- 4 Remove the 'O' rings from the body.
- 5 Remove the 'O' rings from the piston.

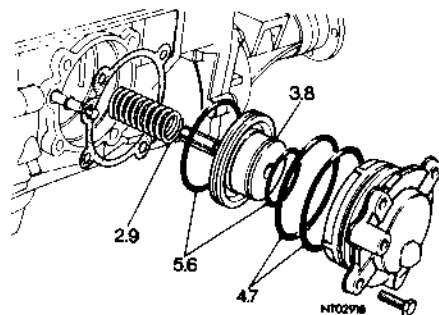
**Reassembling**

- 6 Fit the 'O' rings to the piston.
- 7 Fit the 'O' rings to the body.
- 8 Refit the piston.
- 9 Fit the spring.
- 10 Refit the servo assembly.

**REAR SERVO**

Remove and refit 44.34.13

Service tool: CBW 547A-50

- 1 Remove the exhaust front pipe. 30.10.09.

**Removing**

- 2 Unscrew the six bolts.
- 3 Withdraw the servo and joint washer together with 'O' rings, spring and push-rod.

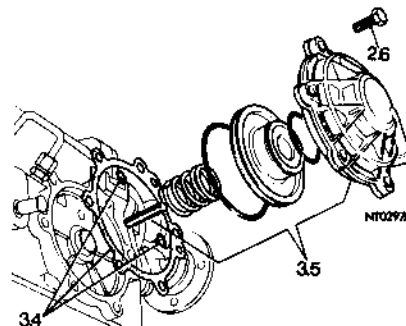
**Refitting**

- 4 Locate the 'O' rings and joint washer onto the gearbox casing.
- 5 Fit the servo assembly, spring and push-rod.
- 6 Fit and tighten the six bolts using CBW 547A-50.
- 7 Refit the exhaust front pipe. 30.10.09.

**REAR SERVO**

Overhaul 44.34.16

- 1 Remove the rear servo. 44.34.13.

**Dismantling**

- 2 Remove the push-rod.
- 3 Remove the spring.
- 4 Withdraw the piston using air pressure.
- 5 Remove the 'O' rings.

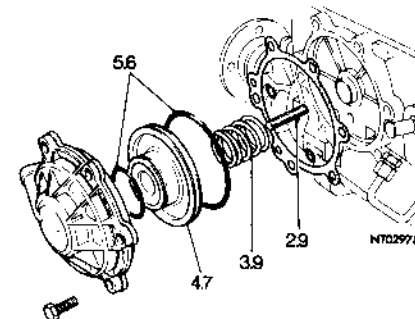
**Reassembling**

- 6 Fit the 'O' rings to the piston.
- 7 Refit the piston.
- 8 Refit the spring.
- 9 Refit the push-rod.
- 10 Refit the rear servo.

## OUTPUT SHAFT

Remove and refit 44.36.01

Service tools: CBW 60, RG 421 or S 337, CBW 547A-50

### Removing

- 1 Remove the transmission unit. 44.20.01.
- 2 Wash the exterior of the unit in clean petrol or paraffin, invert it and place on a bench cradle CBW 60. Remove the switch. 44.15.15.
- 3 Unscrew the bolts securing the torque converter housing.
- 4 Remove the torque converter housing.
- 5 Unscrew 12 bolts.
- 6 Remove the oil pan, joint washer and magnet.
- 7 Pull out the oil tubes.
- 8 Release the downshift inner cable from the downshift cam.
- 9 Take out three bolts and washers.
- 10 Lift off the valve block.
- 11 Unscrew two bolts.
- 12 Remove the oil tube locating plate.
- 13 Pull out the oil tubes. (Note the 'O' ring on the pump suction tube.)
- 14 Take out five bolts.
- 15 Remove the pump and joint washer.
- 16 Remove the thrust washer.
- 17 Withdraw the front clutch.
- 18 Remove the thrust washers.
- 19 Withdraw the rear clutch and forward sun gear.
- 20 Squeeze together the ends of the front brake band and remove it together with the strut.

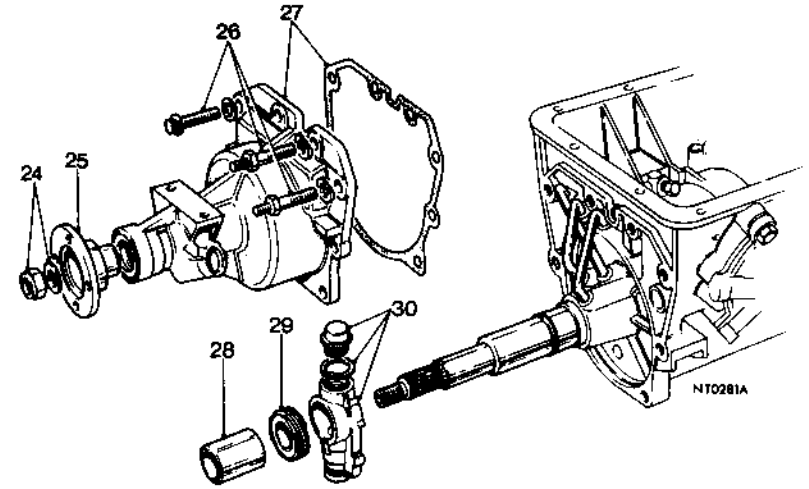
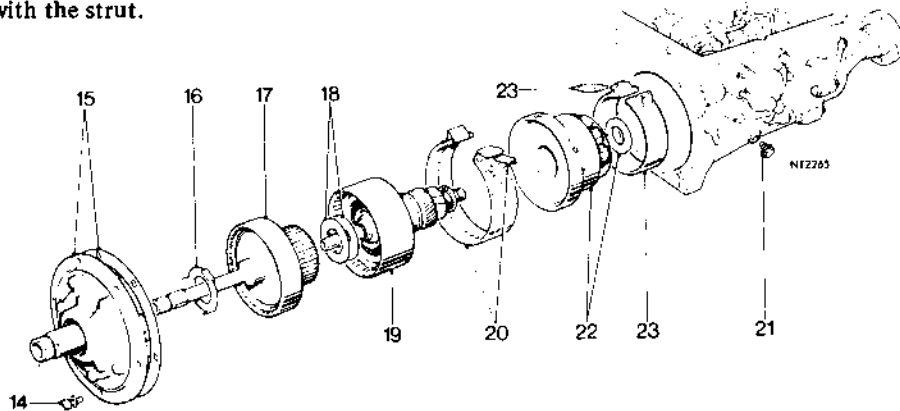
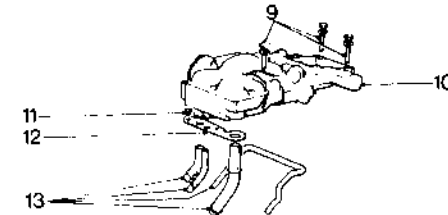
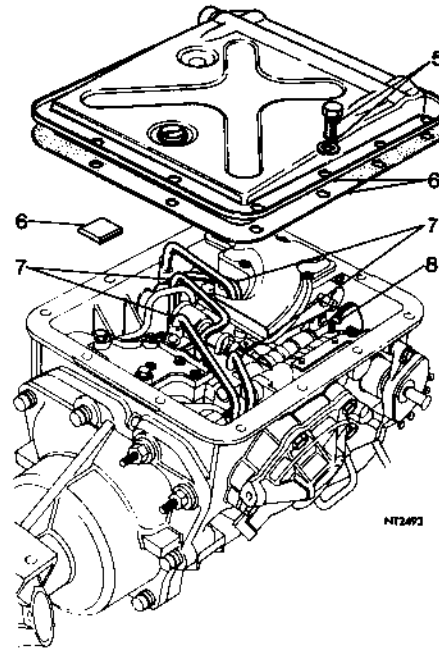

- 21 Unscrew the three bolts.
- 22 Withdraw the centre support/planet gear assembly and needle thrust assembly.
- 23 Squeeze together the ends of the rear brake band, tilt and withdraw together with the strut.
- 24 Using tool no. RG 421 or S 337 to retain the flange, unscrew the nut.
- 25 Withdraw the flange.
- 26 Unscrew the bolts.

- 27 Withdraw the rear extension and joint washer.
- 28 Remove the clamp tube.
- 29 Withdraw the speedometer drive gear.
- 30 Unscrew the counterweight and remove the governor.
- 31 Withdraw the output shaft assembly.
- 32 Remove the thrust washer.
- 33 Remove the circlip.
- 34 Detach the outer annulus from the output shaft.

*continued*

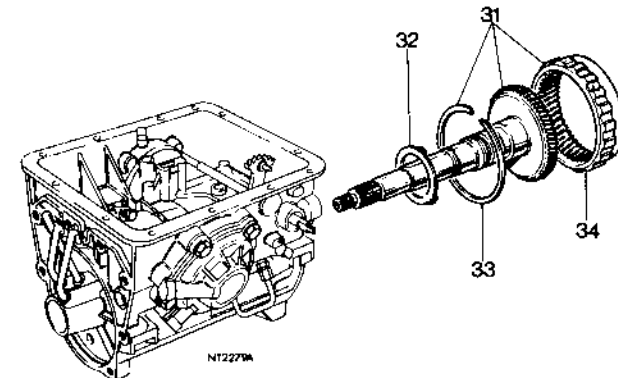

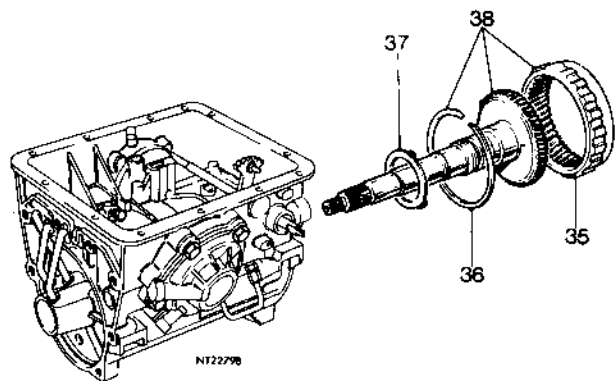
**Refitting**

- 35 Assemble the outer annulus and the output shaft.
- 36 Fit the circlip.
- 37 Using petroleum jelly, stick the thrust washer to the casing.
- 38 Refit the output shaft assembly.
- 39 Refit the governor and secure it with the counterweight.
- 40 Refit the speedometer drive gear.
- 41 Refit the clamp tube.
- 42 Refit the rear extension, using a new joint washer if necessary.

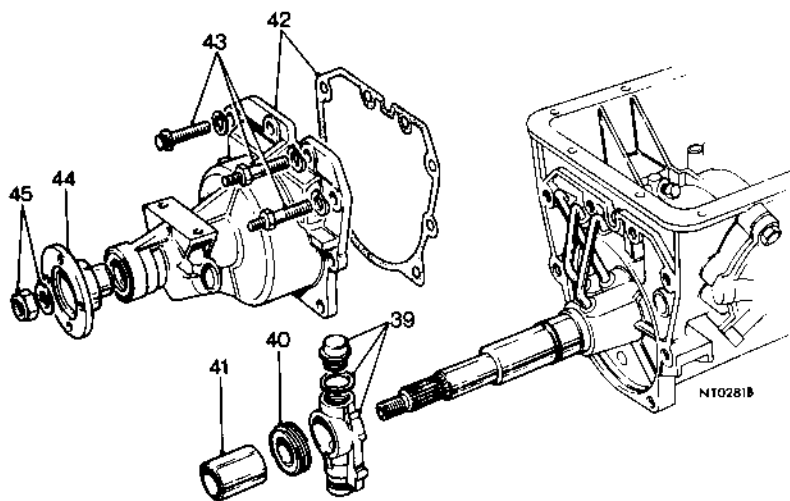

- 43 Fit and tighten the bolts.
- 44 Refit the flange.
- 45 Holding the flange with tool no. RG 421 or S 337, fit and tighten the nut.
- 46 Using petroleum jelly, stick the needle thrust bearing onto the planet gear case (rear drum).
- 47 Refit the rear brake band and strut.
- 48 Refit the centre support/planet gear assembly, ensuring that the oil and locating holes align with those in the casing.

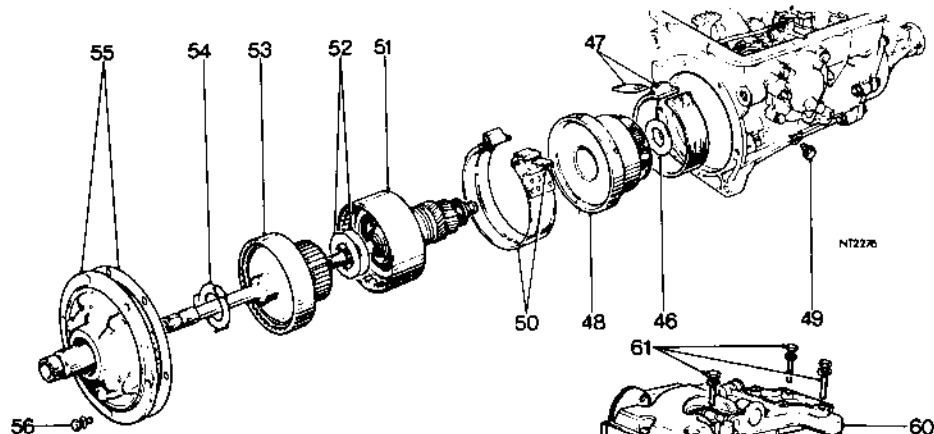

- 49 Fit and tighten the bolts.
- 50 Squeeze together the ends of the front brake band and fit it in position together with the strut.
- 51 Refit the rear clutch and forward sun gear assembly.
- 52 Using petroleum jelly, stick the thrust washers to the rear clutch assembly (phosphor bronze towards the front clutch).
- 53 Refit the front clutch assembly.
- 54 Using petroleum jelly, stick the thrust washer to the pump assembly.
- 55 Refit the pump assembly and joint washer.
- 56 Fit and tighten the bolts.
- 57 Refit the oil tubes. (Note the 'O' ring on the pump suction tube.)
- 58 Refit the oil tube locating plate.
- 59 Fit and tighten the two bolts.
- 60 Carefully refit the valve block, ensuring that the oil tubes are not distorted.
- 61 Fit and tighten the three bolts and washers.
- 62 Connect the downshift inner cable to the downshift cam.
- 63 Refit the oil tubes.
- 64 Replace the magnet and refit the oil pan and joint washer.
- 65 Fit and tighten 12 bolts.
- 66 Locate the torque converter housing in place.
- 67 Fit and tighten four bolts securing the torque converter housing.
- 68 Refit the switch. 44.15.15.
- 69 Refit the transmission unit. 44.15.15.

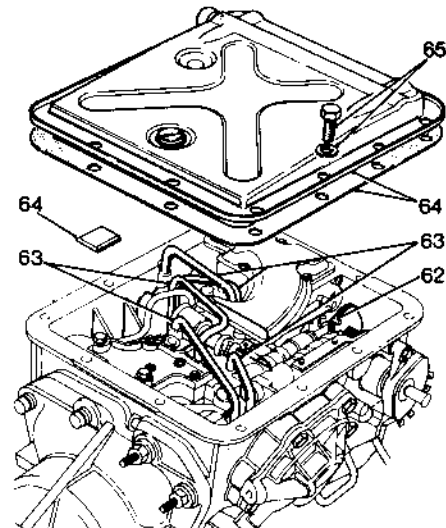
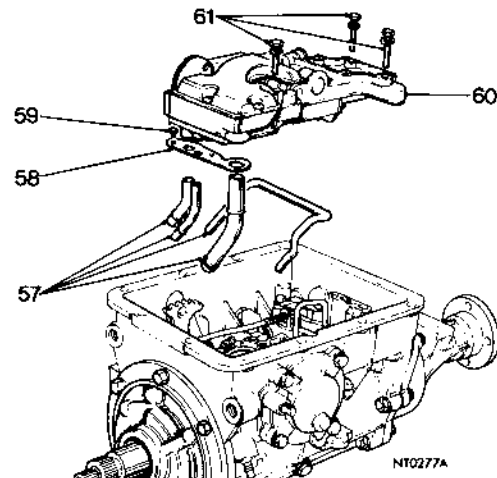

## PLANET GEARS AND REAR DRUM ASSEMBLY

Remove and refit

44.36.04

Service tools: CBW 60, CBW 547A-50

### Removing

- 1 Remove the transmission unit. 44.20.01.
- 2 Wash the exterior of the unit in clean petrol or paraffin, invert it and place on a bench cradle CBW 60. Remove the switch. 44.15.15.
- 3 Unscrew the bolts securing the torque converter housing.
- 4 Remove the torque converter housing.
- 5 Unscrew 12 bolts.
- 6 Remove the oil pan, joint washer and magnet.
- 7 Pull out the oil tubes.
- 8 Release the downshift inner cable from the downshift cam.
- 9 Take out three bolts and washers.
- 10 Lift off the valve block.
- 11 Unscrew two bolts.
- 12 Remove the oil tube locating plate.
- 13 Pull out the oil tubes. (Note the 'O' ring on the pump suction tube.)
- 14 Take out five bolts.
- 15 Remove the pump and joint washer.
- 16 Remove the thrust washer.
- 17 Withdraw the front clutch.
- 18 Remove the thrust washers.
- 19 Withdraw the rear clutch and forward sun gear.
- 20 Squeeze together the ends of the front brake band and remove it together with the strut.
- 21 Take out three bolts.

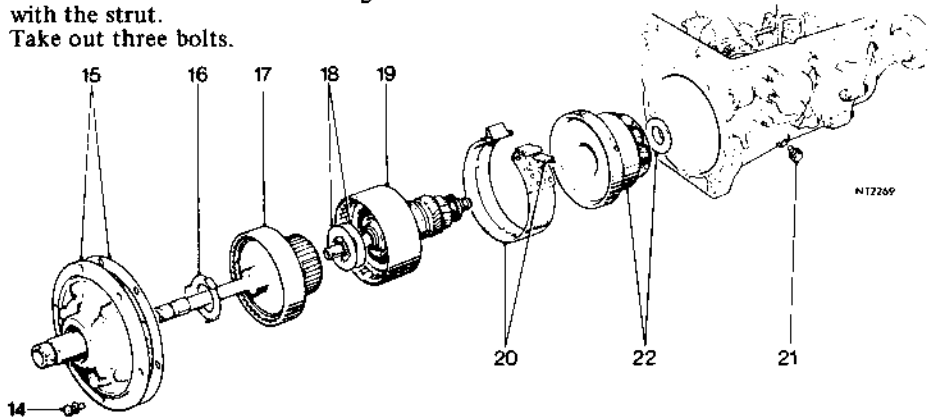
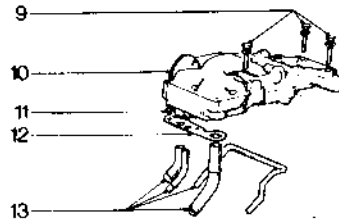
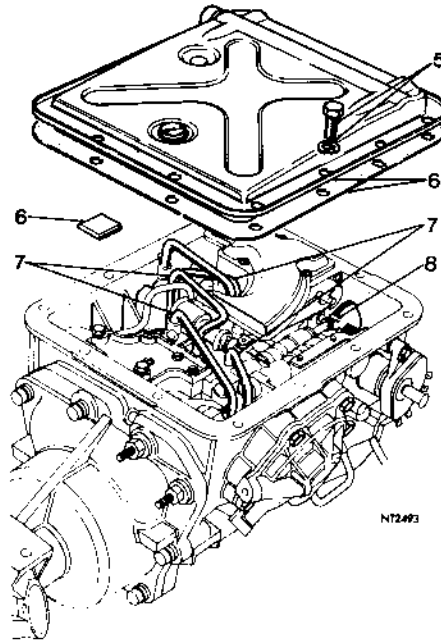

- 22 Withdraw the centre support/planet gear assembly.
- 23 Separate the centre support from the planet gear assembly.
- 24 Withdraw the uni-directional clutch.
- 25 Remove the circlip.
- 26 Detach the uni-directional clutch outer race.

### Refitting

- 27 Fit the uni-directional clutch outer race to the rear drum assembly.
- 28 Fit the circlip.
- 29 Refit the uni-directional clutch.
- 30 Assemble the centre support and planet gear assembly.
- 31 Refit the centre support/planet gear assembly, ensuring that the oil and locating holes align with those in the casing.
- 32 Fit and tighten the bolts.
- 33 Squeeze together the ends of the front brake band and fit it in position together with the strut.
- 34 Refit the rear clutch and forward sun gear assembly.
- 35 Using petroleum jelly, stick the thrust washers to the rear clutch assembly (phosphor bronze towards the front clutch).

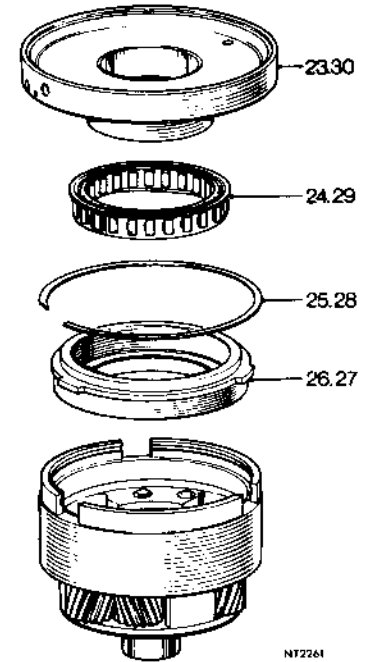

continued

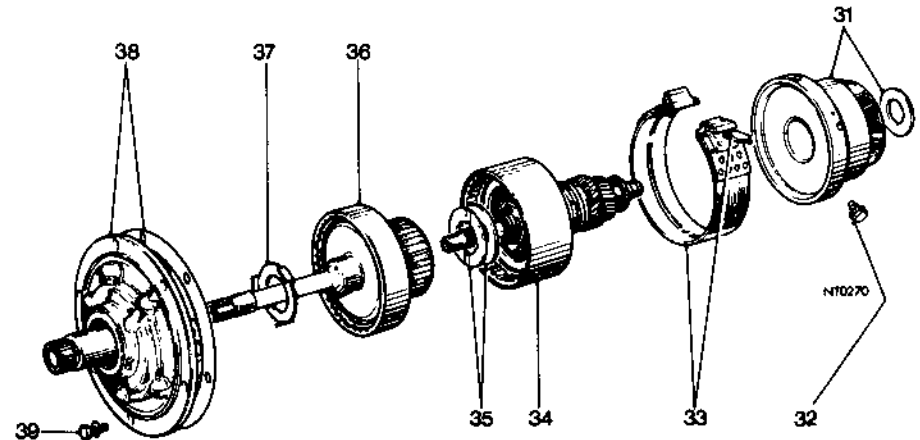

- 36 Refit the front clutch assembly.
- 37 Using petroleum jelly, stick the thrust washer to the pump assembly.
- 38 Refit the pump assembly and joint washer.
- 39 Fit and tighten the bolts.
- 40 Refit the oil tubes. (Note the 'O' ring on the pump suction tube.)
- 41 Refit the oil tube locating plate.
- 42 Fit and tighten the two bolts.
- 43 Carefully refit the valve block, ensuring that the oil tubes are not distorted.
- 44 Fit and tighten the three bolts and washers.
- 45 Connect the downshift inner cable to the downshift cam.
- 46 Refit the oil tubes.
- 47 Replace the magnet and refit the oil pan and joint washer.
- 48 Fit and tighten 12 bolts.
- 49 Locate the torque converter housing in place.
- 50 Fit and tighten four bolts securing the torque converter housing.
- 51 Refit the switch. 44.15.15.
- 52 Refit the transmission unit.

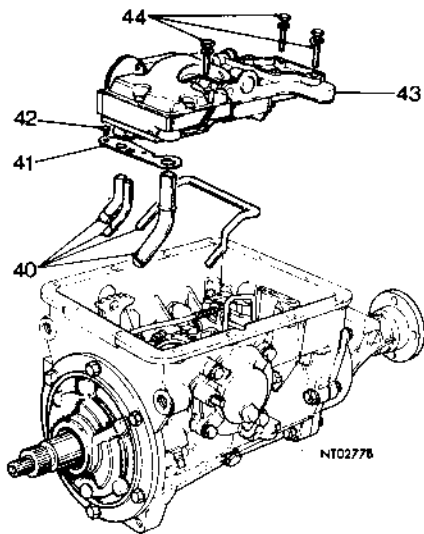
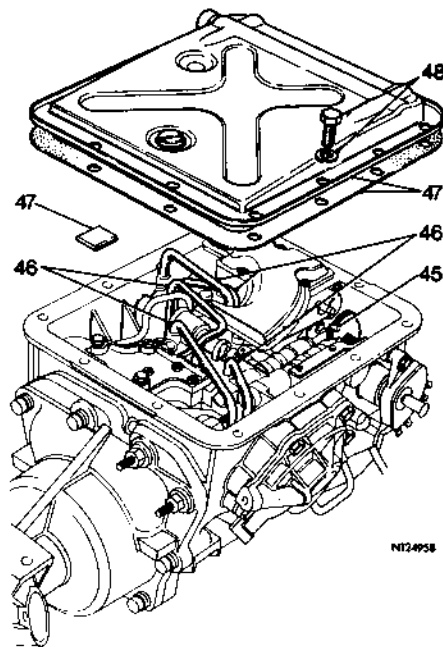

### SPEEDOMETER DRIVE PINION

Remove and refit 44.38.04

#### Removing

- 1 Drive the vehicle onto a ramp, apply the hand brake and raise the ramp.
- 2 Disconnect the speedometer cable from the gearbox.
- 3 Carefully prise the speedometer pinion housing out of the extension.
- 4 Withdraw the pinion from the housing.
- 5 Remove the 'O' ring.
- 6 Extract the seal.

#### Refitting

- 7 Press a new seal into the housing.
- 8 Fit a new 'O' ring to the housing.
- 9 Fit the drive pinion into the housing.
- 10 Press the housing into the rear extension.
- 11 Refit the speedometer cable.
- 12 Lower the ramp.

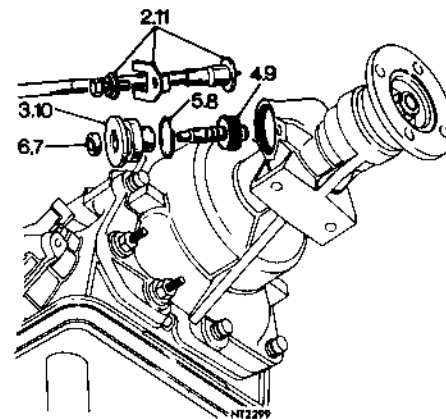

### VALVE BLOCK

Remove and refit 44.40.01

#### Removing

- 1 Remove the sump pan, 44.24.04, and remove the switch. 44.15.15.
- 2 Remove the magnet.
- 3 Pull out the oil connector pipes.
- 4 Disconnect the downshift cable from the cam.
- 5 Take out three bolts.
- 6 Release the valve block.

#### Refitting

- 7 Ensure that the pipes are correctly located.
- 8 Fit the valve block to the unit.
- 9 Secure with three bolts.
- 10 Attach the downshift cable to the cam, ensuring that the cam is correctly located on the manual valve.
- 11 Refit the oil connector pipes.
- 12 Attach the magnet to one end of the bolt heads.
- 13 Refit the switch. 44.15.15.
- 14 Replace the sump pan. 44.24.04.

### SPEEDOMETER DRIVE GEAR

Remove and refit 44.38.07

#### Removing

- 1 Remove the rear extension. 44.20.15.
- 2 Remove the clamp tube.
- 3 Withdraw the speedometer drive gear.

#### Refitting

- 4 Fit the speedometer drive gear.
- 5 Refit the clamp tube.
- 6 Refit the rear extension. 44.20.15.

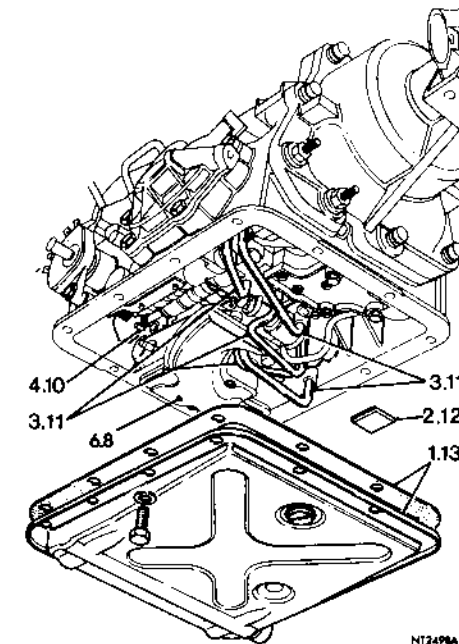
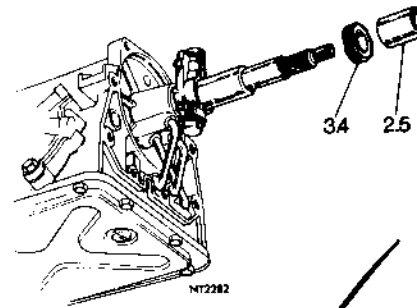



## VALVE BLOCK

Overhaul

44.40.04

Service tool: CBW 548

1 Remove the valve block, 44.40.01.

### Dismantling

- 2 Take out two screws.
- 3 Remove the downshift cam assembly.
- 4 Take out four screws.
- 5 Remove the oil strainer and gasket.
- 6 Take out screw.
- 7 Remove detent spring and spacer.
- 8 Take out eight screws.
- 9 Remove upper valve body.
- 10 Take out eight screws.
- 11 Remove the oil tube collector.
- 12 Take out four screws.
- 13 Remove the governor line plate.
- 14 Remove the separating plate.
- 15 Remove the check valve.
- 16 Remove the check valve ball and spring.
- 17 Remove the servo orifice control valve spring and stop.
- 18 Remove the throttle valve stop and return spring.
- 19 Remove the throttle valve plate.
- 20 Withdraw the manual control valve.
- 21 Withdraw the downshift valve.
- 22 Remove the throttle valve spring.
- 23 Withdraw the throttle valve.
- 24 Tap out the dowel pin, applying light pressure to the plug.
- 25 Withdraw the modulator plug.
- 26 Withdraw the modulator valve.
- 27 Withdraw the modulator valve spacer.
- 28 Withdraw the modulator valve spring.
- 29 Withdraw the servo orifice control valve.
- 30 Slacken progressively the three screws.
- 31 Carefully remove the end plate.
- 32 Remove the spring.
- 33 Withdraw the sleeve.
- 34 Take out the primary regulator valve.
- 35 Remove the spring.
- 36 Withdraw the secondary regulator valve.
- 37 Remove the screws from the upper valve body.

- 38 Remove the front end plate.
- 39 Take out three screws.
- 40 Remove the rear end plate.
- 41 Withdraw the 2-3 shift valve from the rear.
- 42 Remove the spring.

- 43 Withdraw the plunger.
- 44 Withdraw the 1-2 shift valve from the rear.
- 45 Remove the spring.
- 46 Withdraw the plunger.

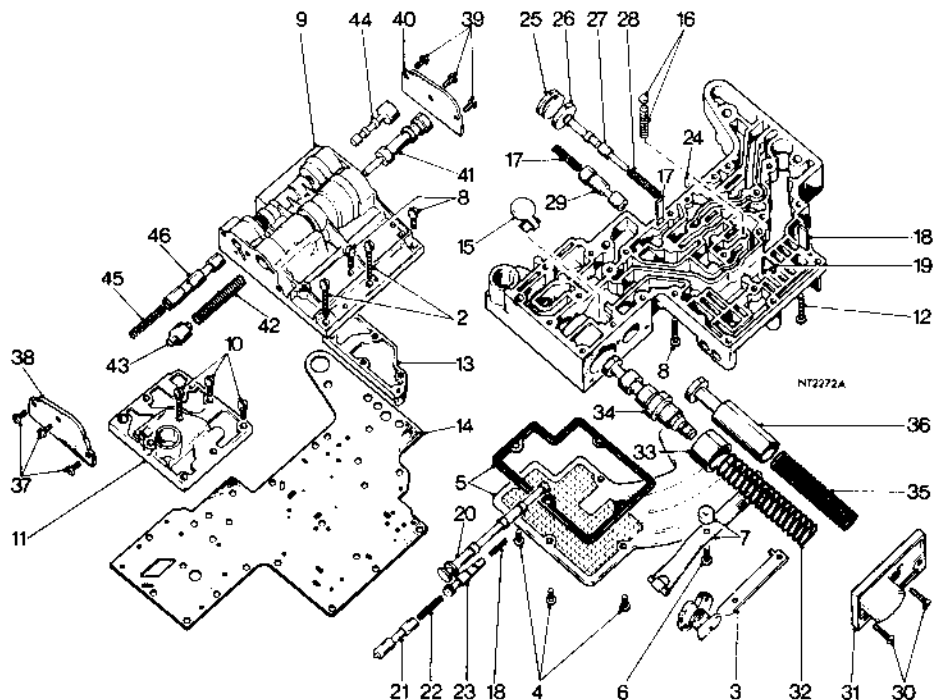

### Reassembling

- 47 Insert the 1-2 shift valve.
- 48 Insert the 2-3 shift valve.
- 49 Replace the rear end plate.
- 50 Fit and tighten the three screws.
- 51 Insert the 1-2 shift valve plunger.
- 52 Insert the 2-3 shift valve spring.
- 53 Insert the 1-2 shift valve spring.
- 54 Insert the 2-3 shift valve plunger.
- 55 Locate the front end plate in position.
- 56 Fit and tighten three screws.
- 57 Insert the secondary regulator valve into the lower valve body.
- 58 Refit the spring.
- 59 Insert the primary regulator valve.
- 60 Insert the sleeve.
- 61 Insert the spring.
- 62 Hold the end plate in position.
- 63 Fit and tighten the three screws.
- 64 Insert the servo orifice control valve.
- 65 Insert the spring.
- 66 Depress the spring and fit the stop.
- 67 Insert the modulator control valve spring.
- 68 Insert the spacer.
- 69 Insert the modulator control valve.
- 70 Insert the plug.
- 71 Fit the dowel pin.
- 72 Insert the throttle valve.
- 73 Insert the spring.
- 74 Insert the downshift valve.
- 75 Insert the manual control valve.
- 76 Insert the throttle valve return spring and stop.
- 77 Refit the throttle valve plate.
- 78 Refit the check valve ball and spring.
- 79 Refit the check valve.
- 80 Place the separating plate in position.
- 81 Hold the governor line plate in position.
- 82 Fit and loosely tighten the four screws.
- 83 Replace the oil tube collector.
- 84 Fit and loosely tighten eight screws.
- 85 Replace the upper valve body.
- 86 Fit and tighten the eight screws.
- 87 Refit the oil strainer and gasket.
- 88 Fit and tighten four screws.
- 89 Refit the detent spring and spacer.
- 90 Fit and tighten the screw.
- 91 Tension the downshift cam and refit the assembly.
- 92 Fit and tighten two screws.
- 93 Refit the valve block, 44.40.01.

**PROPELLER SHAFT****Remove and refit** 47.15.01**Removing**

- 1 Scribe the gearbox flange, rear axle flange, and propeller shaft flanges to enable reassembly in original locations.
- 2 Remove the four bolts and nyloc nuts

securing the propeller shaft and gearbox flanges.

- 3 Remove the four bolts and nyloc nuts securing the propeller shaft and rear axle pinion flanges.
- 4 Remove the propeller shaft.

**Refitting**

- 5 Reverse instructions 1 to 4.

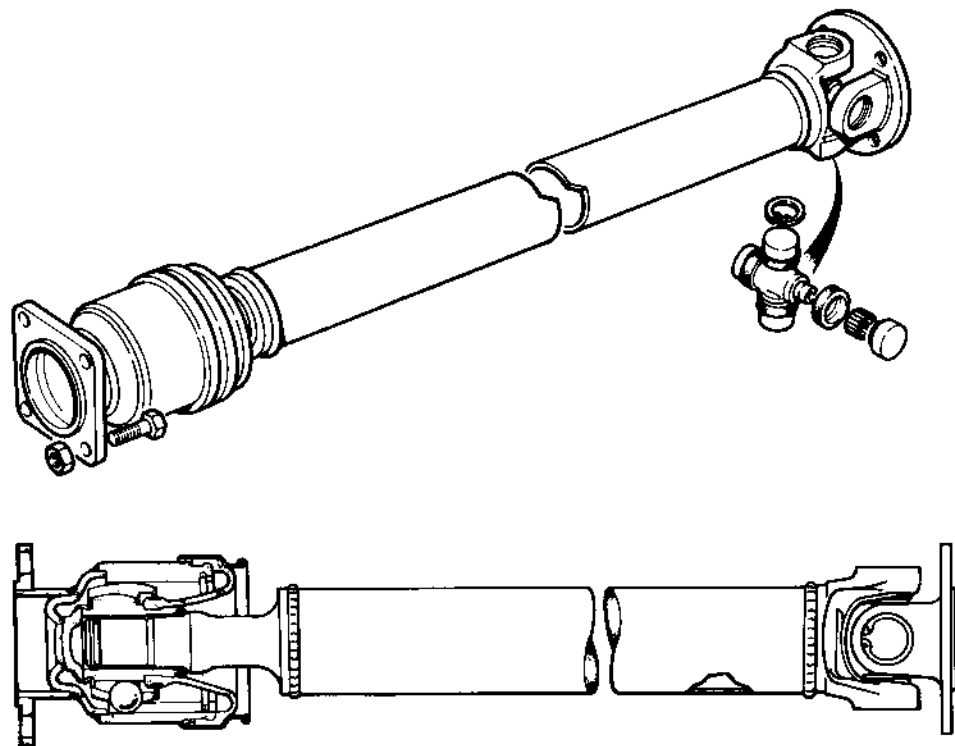

A47-4

*Early type shown -***UNIVERSAL JOINT (Early types)****Remove and refit** 47.15.18**Removing**

- 1 Remove the propeller shaft, see 47.15.01.
- 2 Remove paint, rust, etc., from the vicinity of the bearing cups and circlips.
- 3 Remove the circlips.
- 4 Tap the bearing yokes to eject the bearing cups.
- 5 Withdraw the bearing cups and spider.

**Refitting**

- 6 Remove the bearing cups from the new spider.
- 7 Check that all needles are in place.
- 8 Fit the spider to the yoke.

- 9 Engage the spider trunnion in the bearing cup and insert the cup in the yoke ensuring that the needle bearings are not displaced.
- 10 Fit the opposite bearing cup to the yoke and carefully press both cups into position ensuring that the spider trunnions engage both cups and that the needle bearings are not displaced.
- 11 Using two flat-faced adaptors of slightly smaller diameter than the bearing cups press the cups into the yoke until they reach the lower land of the circlip grooves. Do not press the cups below this point or damage may be caused to the cups and seals.
- 12 Fit the circlips.

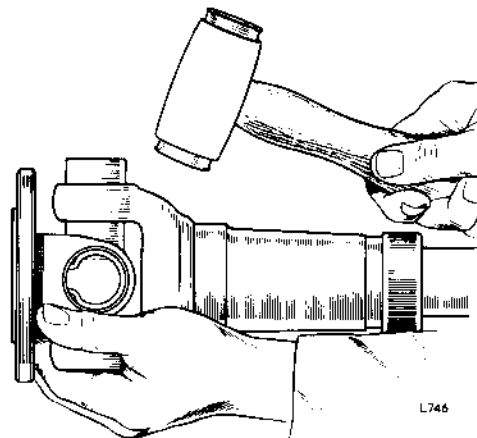

L746

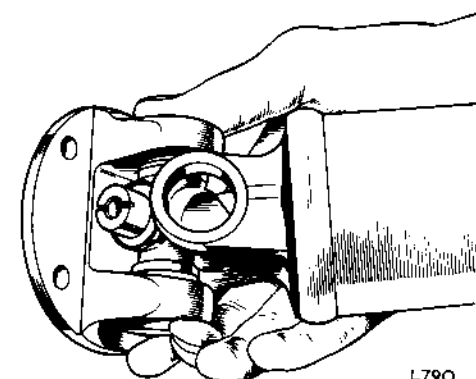

L790

## HALF SHAFT

### Remove and refit

51.10.01

Service tools: S4235A, S4235A-1

#### Removing

- 1 Raise and support the rear of the car.
- 2 Remove the road wheel.
- 3 Remove the split pin, nut and washer securing the hub to the half shaft.
- 4 Remove the brake drum.
- 5 Remove the clevis pin linking the handbrake cable to the wheel cylinder operating lever.
- 6 Disconnect the brake pipe(s) from the wheel cylinder. Seal or blank off the pipe(s) and wheel cylinder to prevent the ingress of dirt.
- 7 Remove the four nuts, spring washers and bolts securing the backplate to the axle flange.
- 8 Using Tool S4235A and adaptor S4235A-1 withdraw the half shaft complete with hub, backplate, oil catcher plate, oil seal and housing and bearing retaining plate.

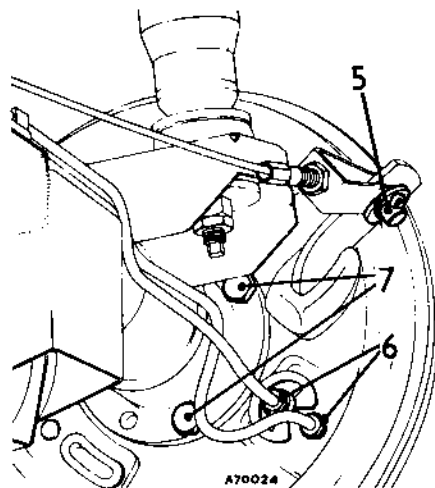

#### Refitting

- 9 Pack the half shaft bearing with a lithium base grease.
- 10 Fit the half shaft complete with hub, backplate, oil catcher plate, and oil seal and housing to the axle casing.
- 11 Align the holes in the oil seal housing plate, bearing retainer plate, backplate and oil catcher. Ensuring that the oil drain hole in the oil seal housing corresponds with the drain hole in the axle flange. Note that the trough of the oil catcher plate must be fitted below the half shaft.
- 12 Fit the four bolts, spring washers and nuts securing the backplate to the axle casing.
- 13 Fit the hub securing washer and nut and torque to 100-110 lbf ft (13,83-15,21 kgf m).
- 14 Connect the brake pipe(s).
- 15 Connect the hand brake cable.
- 16 Fit the brake drum.
- 17 Fit the road wheel.
- 18 Bleed the brakes.
- 19 Lower the car.

## HALF SHAFT BEARING AND OIL SEAL

### Remove and refit

51.10.02

Service tools: S356C, S4235A, S4235A-1

#### Removing

- 1 Raise and support the rear of the car.
- 2 Remove the road wheel.
- 3 Remove the nut and washer securing the hub to the half shaft.
- 4 Remove the brake drum. using Tool S356C.
- 6 Remove the clevis pin and release the handbrake cable from the wheel cylinder operating lever.
- 7 Disconnect the brake pipe(s) from the wheel cylinder. Seal or blank off the pipe(s) and wheel cylinder connections to prevent the ingress of dirt.
- 8 Remove the four nuts, spring washers and bolts securing the backplate to the axle flange.

- 9 Remove the oil catcher plate. Note that the elongated area of the plate aligns with drain holes in the backplate, oil seal housing and axle casing flange.
- 10 Remove the backplate.
- 11 Remove the hub oil seal housing and gasket. Note that the drain hole aligns with a corresponding hole in the axle casing flange.
- 12 Remove the oil seal from the housing.
- 13 Remove the key from the half shaft.
- 14 Withdraw the half shaft and bearing using Tool S4235A, S4235A-1.
- 15 Remove the inner oil seal from the axle casing.
- 16 Press the bearing from the half shaft.

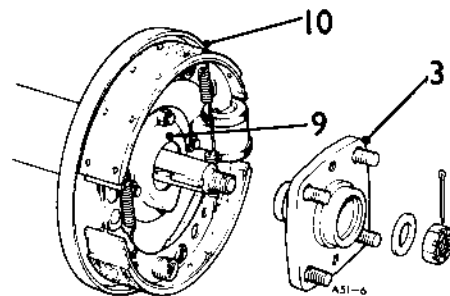

#### Refitting

- 17 Install a new inner seal in the axle casing. The lips of the seal must be towards the differential. Lubricate the seal lips.
- 18 Fit a new hub seal to the housing and lubricate the seal lips. The seal lips must be towards the differential.
- 19 Pack the half shaft bearing with a lithium-base grease and fit the bearing to the half shaft (shielded side of bearing to hub).

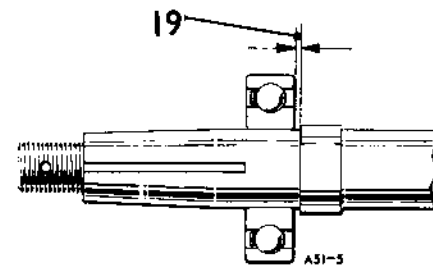

**CAUTION:** The bearing must not abut against the collar on the half shaft. A minimum clearance of 0.16 in (4,1 mm) between the bearing inner track and the half shaft collar is required. (The final, installed position of the bearing is determined by the hub when it is fully tightened).

- 20 Fit the half shaft, hub seal housing and gasket, backplate and oil catcher. Ensure oil drain holes align with the axle casing flange.
- 21 Fit the half shaft key.
- 22 Fit the hub washer and nut and torque to 100-110 lbf ft (13,83-15,21 kgf m).
- 23 Fit the brake drum.
- 24 Connect the brake pipe(s).
- 25 Connect the handbrake cable.
- 26 Fit the road wheel and hub cap.
- 27 Bleed the brakes.
- 28 Lower the car.

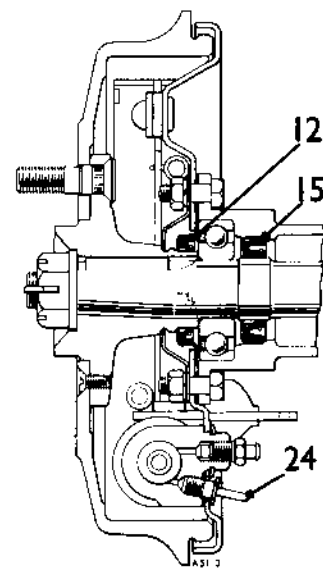

**REAR HUB****Remove and refit** 51.10.18

Service tools: S356C

**Removing**

- 1 Raise and support the rear of the car.
- 2 Remove the road wheel.
- 3 Remove the nut and washer securing the hub to the half shaft.
- 4 Remove the brake drum.
- 5 Withdraw the hub from the half shaft using Tool S356C and the nuts supplied. The standard wheel nuts must not be used for this purpose.

**Refitting**

- 6 Reverse instructions 1 to 5. The nut securing the hub to the half shaft must be torqued to 100-110 lbf ft (13,83-15,21 kgf m).

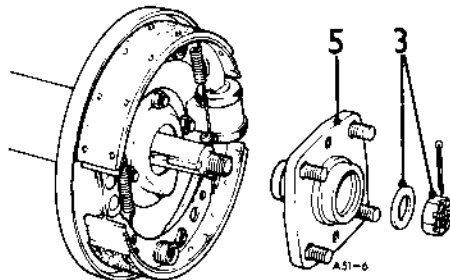
**REAR HUB WHEEL STUDS****Remove and refit** 51.10.19

Service tool: S356C

**Removing**

- 1 Raise the rear of the car and support securely.
- 2 Remove the rear hub. 51.10.18.
- 3 Drive out the wheel studs.

**Refitting**

- 4 Ensure that mating, tapered faces of studs and wheel hub are clean.
- 5 Enter the stud in the hub ensuring splines engage.
- 6 Drive or press the stud into position.
- 7 Fit the rear hub. 51.10.18.
- 8 Lower the car.

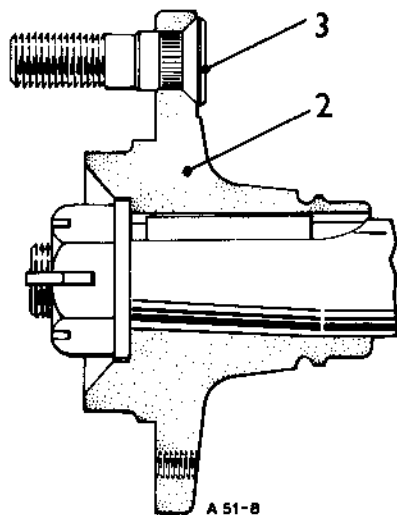
**DIFFERENTIAL ASSEMBLY****Remove and refit** 51.15.01

Service tools: S4235A, S4235A-1

**Removing**

- 1 Jack up or raise the rear of the car and support securely.
- 2 Remove both road wheels and hub caps.
- 3 Remove the split pins, nuts and washers securing the hubs to the half shafts.
- 4 Release the handbrake and remove both brake drums.
- 5 Release the handbrake cables from the rear brake cylinder operating levers.
- 6 Disconnect the three brake pipes from the rear wheel cylinders and pipe ends to prevent ingress of grit.
- 7 Remove the four bolts, nuts and spring washers securing each backplate to the axle flanges.
- 8 Fit Tool S4235A and adaptor S4235A-1 to the half shaft and withdraw the half shaft complete with

hub, backplate and bearing. Repeat on other half shaft.

- 9 Remove the four bolts and nuts securing the propeller shaft flange to the differential pinion flange. Release the propeller shaft from the differential pinion.
- 10 Place a container under the differential to collect the oil when the differential is disturbed.
- 11 Remove the nuts and spring washers securing the differential assembly to the axle casing.
- 12 Ease the differential assembly flange from the axle casing and allow the oil to drain into the container.
- 13 Withdraw the differential assembly.

**Refitting**

- 14 Reverse instructions 1 to 13. Note: The hub securing nuts must be torqued to 100-110 lbf ft (13,83-15,21 kgf m).
- 15 Refill the axle with fresh lubricant.
- 16 Bleed the brakes.

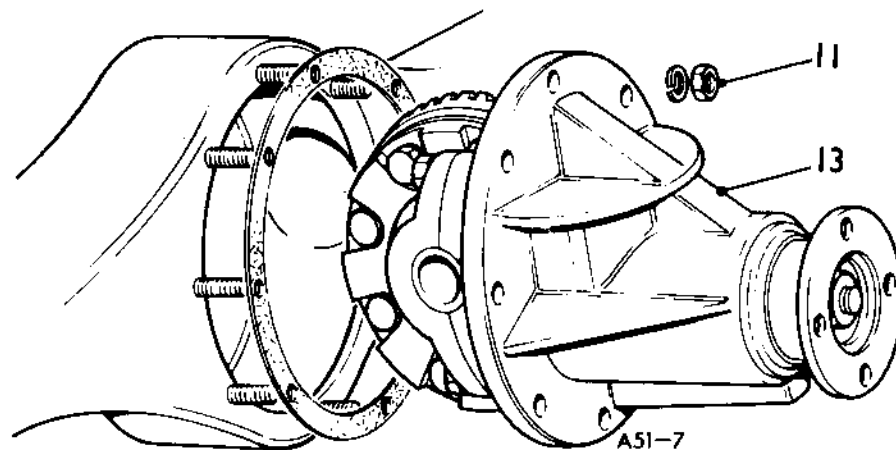

## DIFFERENTIAL ASSEMBLY

Overhaul 51.15.07

Service tools: 47, 18G 47BD, S337 or 18G 1205, S4221A-17, 550, 18G 134DH, 18G 191, 18G 191M, S101

### Dismantling

- 1 Remove the differential assembly. 51.15.01.

### Crown wheel and differential unit

- 2 Place the differential assembly in a vice (crown wheel uppermost).
- 3 Mark the bearing caps to identify original locations.
- 4 Remove the bearing cap bolts and spring washers. (4).
- 5 Remove the bearing caps.
- 6 Carefully lever the crown wheel and differential unit clear of the assembly housing.
- 7 Lift out the crown wheel and differential unit complete with carrier bearings and shims.
- 8 Using press 47 and adaptor 18G 47BD withdraw the carrier bearings.
- 9 Remove the eight bolts and spring washers securing the crown wheel to the differential unit and withdraw the crown wheel.
- 10 Drive out the pin retaining the differential pinion pin.
- 11 Remove the differential pinion pin.
- 12 Rotate the differential sun wheels to bring the planet wheels and their respective selective thrust washers clear of the differential unit.
- 13 Remove the two planet wheels and thrust washers.
- 14 Remove the two sun wheels and thrust washers.

### Pinion and bearings

- 15 Locate the differential assembly housing horizontally in the vice.
- 16 Remove the cap from the differential pinion flange.
- 17 Using Tool S337 to hold the pinion flange remove the pinion shaft nut and washer.
- 18 Withdraw the pinion flange.

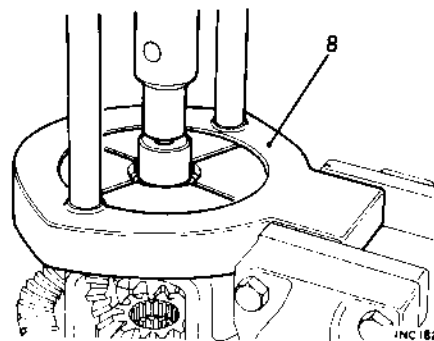
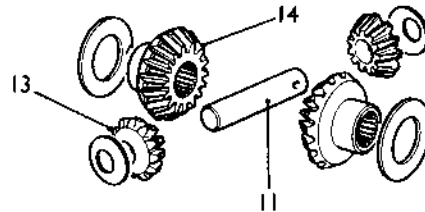
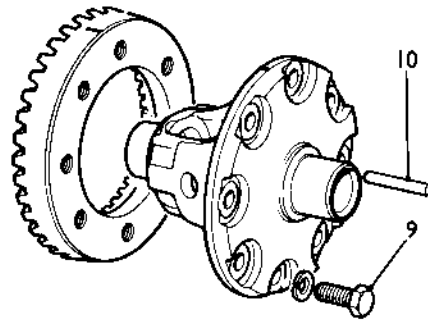
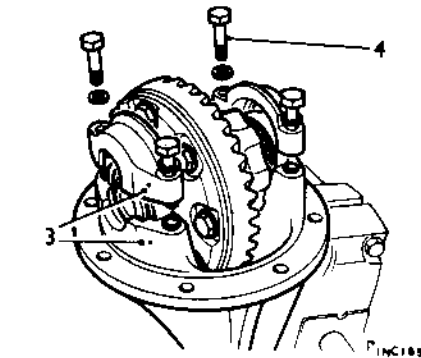

- 19 Using a hardwood block carefully tap out the pinion complete with pinion head bearing, selective washer and collapsible spacer.
- 20 Carefully drive out the pinion outer bearing and oil seal.
- 21 Evenly drift out both bearing outer tracks.
- 22 Using press 47 and adaptor S4221A-17 remove the pinion head bearing and selective washer.
- 23 Thoroughly clean all components.

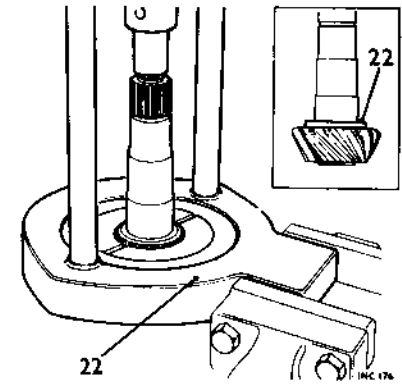
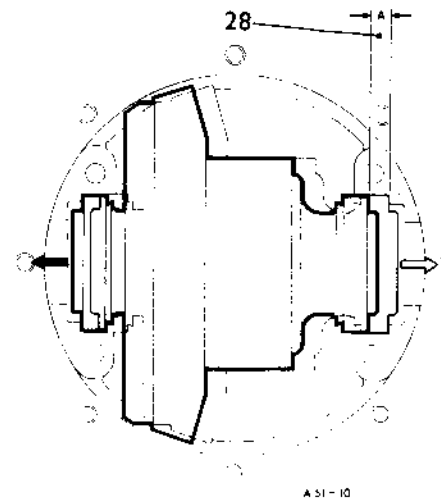
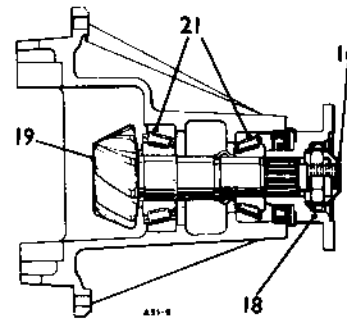

### Assembling

#### Crown wheel and differential unit

- 24 Using Tool 550 and 18G 134DH fit the carrier bearings to the differential unit. (Tapered face of bearings towards half shafts.)
- 25 Lightly lubricate the carrier bearings and locate the differential unit in the differential casing.
- 26 Rotate the differential unit to allow the bearings to settle and push the differential unit complete with bearings to one side of the differential casing.
- 27 Using a dial gauge mounted against the crown wheel mounting flange check for 'run-out'. If 'run-out' is found to exceed 0.003 in (0,08 mm) it will be necessary to remove the carrier bearings and renew the differential unit housing. Ensure before discarding the differential unit housing that the excessive 'run-out' reading obtained is not due to improperly seated bearing cups. If 'run-out' is within 0.003 in (0,08 mm) proceed as follows:
- 28 Ensuring that the bearing cups are properly in contact with the bearings, float the differential unit laterally until it butts against the bearing seats in either direction. Using the dial gauge measure this lateral free movement. Call the measurement Dimension 'A'. Record Dimension 'A' as it will be used later to determine the required shim pack for the carrier bearings and to obtain correct pinion backlash.

continued

- 29 Remove the differential unit complete with bearings.
- 30 Lightly lubricate the sun wheel thrust faces and thrust washers and install them in the differential unit.
- 31 Mesh the planet wheels with the sun wheels ensuring the planets are diametrically opposite and rotate both sun wheels to bring the planets into their position in the differential unit casing.
- 32 Fit the differential pinion pin.
- 33 Check and assess the planet end-float.
- 34 Remove the pinion pin and rotate both sun wheels to bring the planets clear of the differential unit casing.
- 35 Lubricate the planet thrust washers selected and slide the planets and washers into position. Fit the pinion pin and again check the planets for end-float and backlash. Zero backlash is required. Choose thrust washers as appropriate from the nine thicknesses available.
- 36 Fit the retaining pin to the pinion pin and stave the casing.
- 37 Fit the crown wheel.
- 38 Smear the threads of the crown wheel securing bolts with 'Locquic' grade 'T' primer and 'Locquic 75' compound. Fit the bolts and spring washers and evenly tighten to the recommended torque.

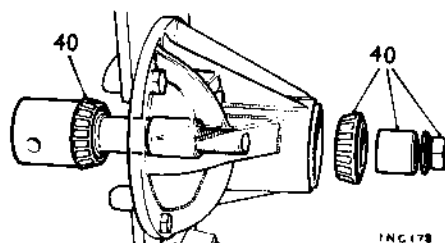
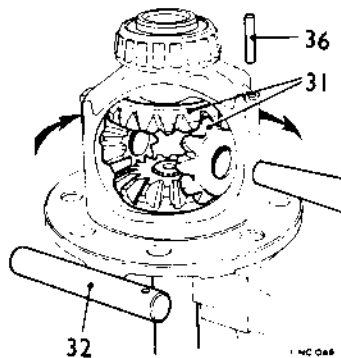

#### Pinion and bearings

- 39 Fit the pinion inner bearing to the dummy pinion 18G 191M. The standard pinion head spacer 0.077 in (1.95 mm) is incorporated in the dimensions of the dummy pinion.
- 40 Lightly lubricate the bearings and fit the dummy pinion, bearings spacer, washer and nut.
- 41 Gradually tighten the nut until a bearing pre-load of 15 to 18 lbf in (0.17 to 0.21 kgf m) is obtained. This can be measured using a lbf in (kgf m) scale torque wrench and a suitable size socket spanner.
- 42 Ensure the face of the dummy pinion is clean. Position the dial gauge foot of 18G 191 on the dummy head and zero the gauge on to the head.

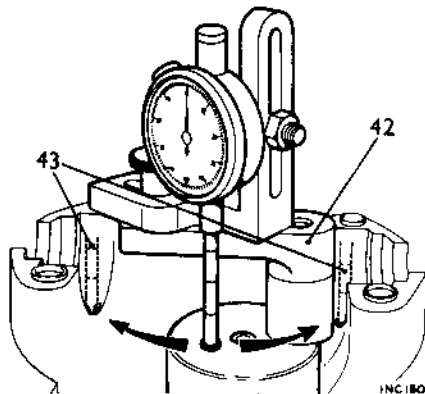

- 43 Move the gauge foot over the centre of one differential bearing bore. Note the indicated measurement. Repeat for the opposite bearing bore.
- 44 Add the two measurements and divide by two.
- 45 Twenty-two pinion head washers are available ranging from 0.075 to 0.096 in (1.91 to 2.44 mm).
- 46 Remove the dummy pinion 18G 191M and dismantle.

#### Calculating pinion head spacer size

##### Example

Sum of each bore measurement  
divided by two . . . . .0.002 in (0,051 mm)  
Plus dummy pinion spacer  
allowance . . . . .0.077 in (1,956 mm)  
Required size of pinion  
head spacer . . . . .0.079 in (2,007 mm)

NOTE: Etched + or - markings will be found on the pinion face.

These markings should be ignored since they are allowed for in the design and method of using the dummy pinion.

- 47 Fit the correct pinion head spacer to the pinion.
- 48 Fit the inner bearing to the pinion using S4221 A-17.
- 49 Insert the pinion, spacer and bearing in the differential casing.
- 50 Fit a new collapsible spacer and the outer bearing to the pinion shaft.
- 51 Fit a new oil seal (lips towards pinion). The seal should be soaked in clean oil for one hour before fitting.
- 52 Fit the flange, washer and nut to the pinion shaft.
- 53 Gradually tighten the nut checking the bearing pre-load.
- 54 Rotate the flange to settle the bearings. Using an in/lb (kg/m) torque wrench or S98A check the torque required to rotate the flange.
- 55 Tighten the nut as required to obtain a torque (flange rotation) of 13 to 20 lbf in (1.80 to 2.77 kgf m).  
**CAUTION:** If the pinion nut is overtightened and the above torque figure exceeded it will be necessary to renew the collapsible spacer and repeat instructions 53 to 55.

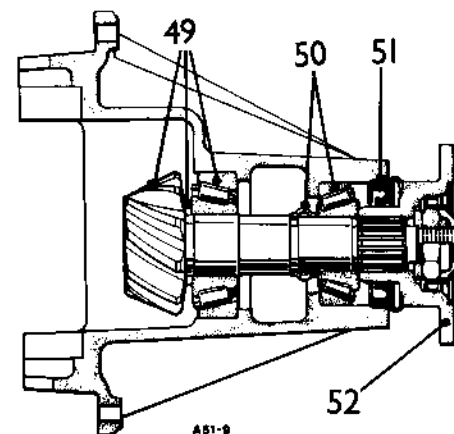
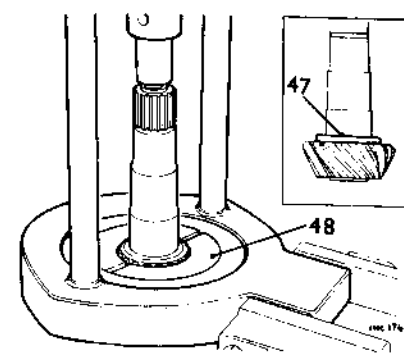

- 56 Place the differential unit/crown wheel assembly complete with bearing cups into position in the differential casing.
- 57 Move the crown wheel fully into mesh with the pinion and zero the dial gauge on the rear of the crown wheel.
- 58 Move the crown wheel and differential unit fully in the opposite direction. Note the gauge reading. This is the 'IN-OUT' of mesh clearance. Call this dimension 'B'.

### Setting Crown Wheel Backlash

#### Example

'IN-OUT' of mesh' clearance (Dimension B)  
Instruction 58 . . . . . 0.025 in (0,63 mm)

Minus required backlash  
0.005 in . . . . . 0.005 in (0,127 mm)  
0.020 in (0,503 mm)

Plus required carrier bearing pre-load  
divided by two 0.004 in  
2 . . 0.002 in (0,051 mm)  
0.022 in (0,554 mm)

This equals shims required for crown wheel  
side carrier bearing.

Total side clearance (Dimension A)  
Instruction 28 . . . . . 0.060 in (1,52 mm)  
Minus above calculation for crown  
wheel side shims . . . 0.022 in (0,554 mm)  
0.038 in (0,976 mm)

Plus carrier bearing pre-load divided  
by two 0.004 in  
2 . . . . . 0.002 in (0,051 mm)  
0.040 in (2,027 mm)

This equals shims required for carrier  
bearing opposite crown wheel.

- 59 Allocate the shims calculated for each carrier bearing. Shims are available in sizes 0.003 in (0,076 mm), 0.005 in (0,127 mm), 0.010 in (0,25 mm), and 0.020 in (0,50 mm).
- 60 Fit the spreading Tool S101 to the differential casing.
- 61 Carefully stretch the differential casing to permit the differential unit complete with bearings and their respective shim packs to be placed in position.  
**IMPORTANT:** Do not stretch more than is necessary or damage will be caused to the differential casing. Each flat on the turnbuckle is numbered. Do not exceed a stretch beyond three to four flats. The maximum permissible stretch is 0.008 in (0,20 mm). Do not lever against the stretcher.
- 62 Remove the stretcher.
- 63 Fit the bearing caps and the four securing bolts and spring washers. Evenly tighten the four bolts.
- 64 Fit the differential assembly to the axle casing. 51.15.01.

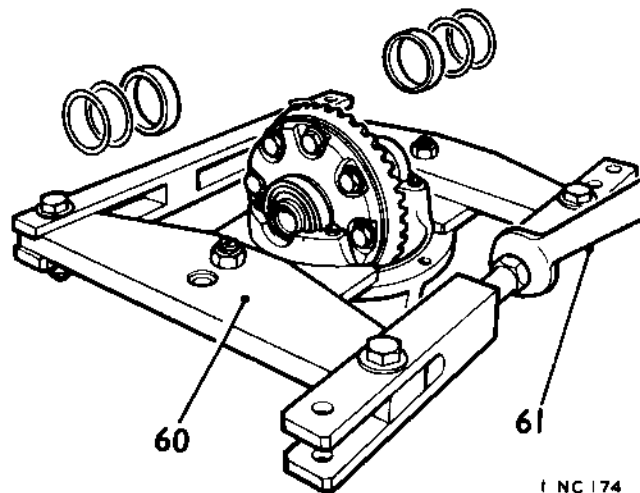

INC 174

### PINION OIL SEAL

Remove and refit 51.20.01

Service tools: S337 or 18G 1205

#### Removing

- 1 Raise the rear of the car and support securely.
- 2 Scribe the propeller shaft rear flange and differential pinion flange to identify original relationship.
- 3 Remove the four bolts and nuts securing the propeller shaft rear flange.
- 4 Release the propeller shaft from the differential pinion.
- 5 Remove the nut shield from the differential pinion flange.
- 6 Using a centre punch carefully mark the flange, pinion shaft and nut to identify original position.
- 7 Using Tool S337 to hold the differential pinion flange, unscrew and remove the nut and washer. Count the number of turns required for nut removal.

- 8 Withdraw the differential pinion flange.
- 9 Extract the pinion oil seal.

#### Refitting

- 10 Fit a new pinion oil seal (lip of seal towards axle).  
Note: This seal should be soaked in engine oil for one hour before installation.
- 11 Fit the differential pinion flange, aligning the flange marking (instruction 6) to the mark in the pinion shaft.
- 12 Fit the washer and nut. Count the number of turns and using Tool S337 to hold the pinion flange, tighten the nut until the pop marks are aligned.
- 13 Fit the nut shield to the flange.
- 14 Fit the propeller shaft noting the flange alignment marks.
- 15 Fit and tighten the shaft four securing bolts and nuts.
- 16 Lower the car.

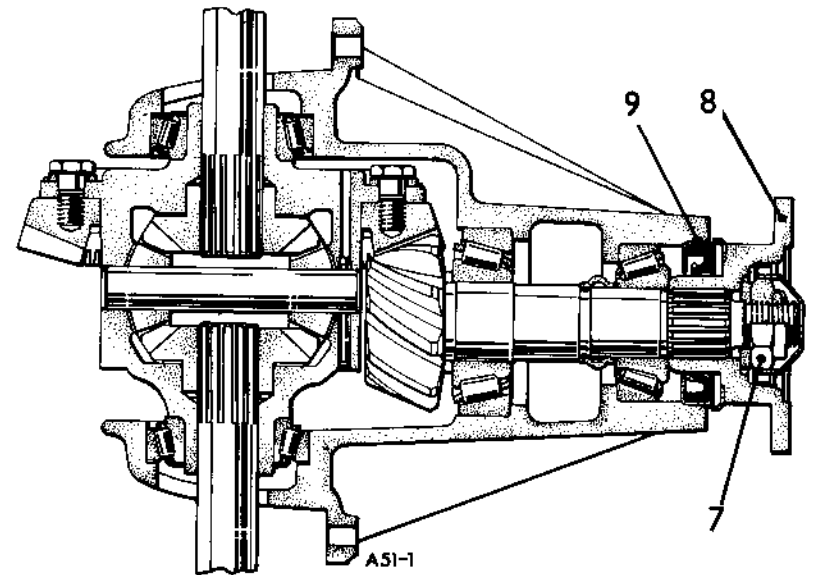

A51-1

**HALF SHAFT INNER OIL SEAL**

Remove and refit 51.20.14

**Removing**

- 1 Remove the half shaft assembly. 51.20.14.
- 2 Remove the half shaft inner oil seal.

**Refitting**

- 3 Evenly install a new half shaft inner oil seal in the axle casing to lips of seal towards differential.
- 4 Lubricate the lips of the seal.
- 5 Refit the half shaft assembly. 51.20.14.

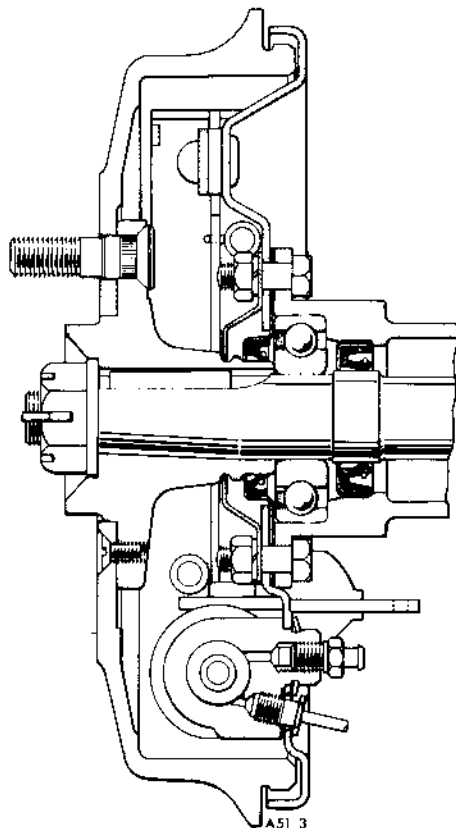
**HUB BEARING OIL SEAL**

Remove and refit 51.20.17

Service tool: S356C

**Removing**

- 1 Raise the car and support securely.
- 2 Remove the rear hub. 51.10.18.
- 3 Disconnect the handbrake cable from the rear wheel cylinder operating lever.
- 4 Disconnect the brake pipe(s) from the rear wheel cylinder, seal the pipe end(s) and cylinder to prevent ingress of dirt.
- 5 Remove the four bolts and nuts securing the backplate to the axle flange.
- 6 Withdraw the oil catcher plate, backplate and the hub oil seal housing and gasket.
- 7 Extract the hub oil seal from its housing. Renew the housing gasket.

**Refitting**

- 8 Fit a new oil seal to the seal housing (seal lips towards differential).
- 9 Lubricate the seal lips and reverse instructions 1 to 6.
- 10 Bleed the brakes.
- 11 Lower the car.

**REAR AXLE ASSEMBLY**

Remove and refit 51.25.01

**Removing**

- 1 Locate a trolley jack under the rear axle, raise the car and support the body securely on stands.
- 2 Remove the rear wheels.
- 3 Disconnect the propeller shaft at the rear axle.
- 4 Disconnect the forward end of the flexible rear brake hose.
- 5 Disconnect the handbrake cable forks at the backplate.
- 6 Remove the nut and bolt clamping the handbrake compensator and release the handbrake cables and trunnion. Withdraw the cables clear of the differential bracket.

- 7 Disconnect the rear dampers at the axle casing bracket.
- 8 Lower the jack and remove the rear road springs.
- 9 Remove the two bolts and nuts securing the radius rods to the axle and detach the handbrake cable bracket from the left hand side.
- 10 Remove the two bolts and nuts securing the axle to the rear suspension arms.
- 11 Lower the jack and release the radius rods from the axle brackets.
- 12 Lift the axle clear of the suspension arms and anti-roll bar and remove from the car.

**Refitting**

- 13 Reverse instructions 1 to 12.
- 14 Bleed the brakes.

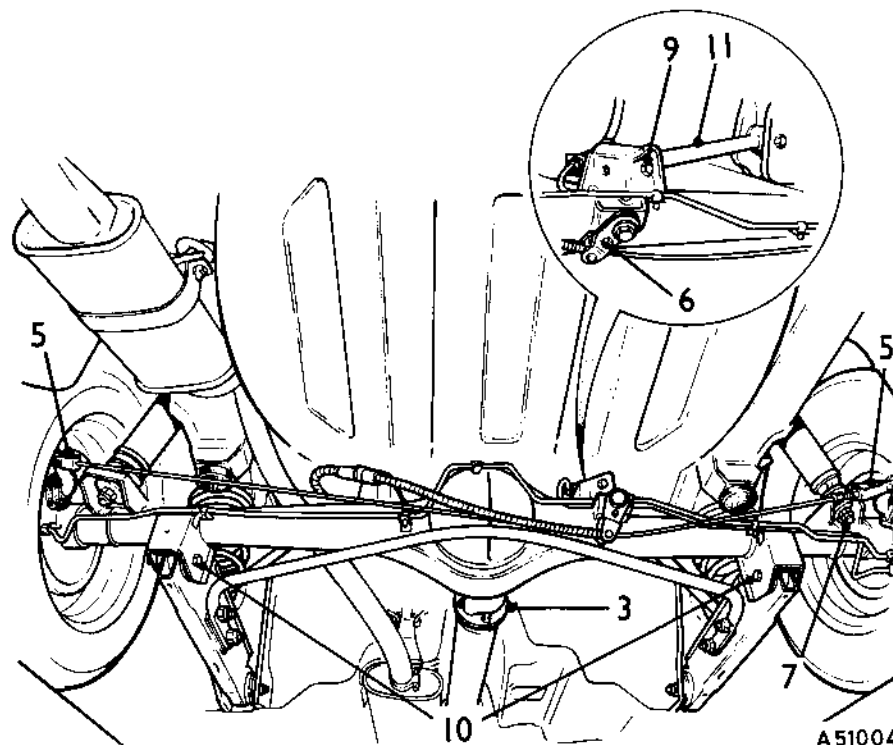



## REAR AXLE CASING

Remove and refit

51.25.04

Service tools: S356C, S4235A, S4235A-1

### Removing

- 1 Raise the rear of the car and support the body securely, on stands.
- 2 Remove the rear axle assembly. 51.25.01.
- 3 Remove the differential assembly. 51.15.01 (exclude instructions 1 and 2).
- 4 Detach the brake pipes from the five nylon clips.
- 5 Unscrew and remove the breather.
- 6 Remove the filler/level plug.

### Refitting

- 7 Remove the brake pipe nylon clips (3 single, 2 double).
- 8 Renew the half shaft inner seals.
- 9 Reverse instructions 1 to 6.
- 10 Refill the casing with fresh lubricant.
- 11 Bleed the brakes.

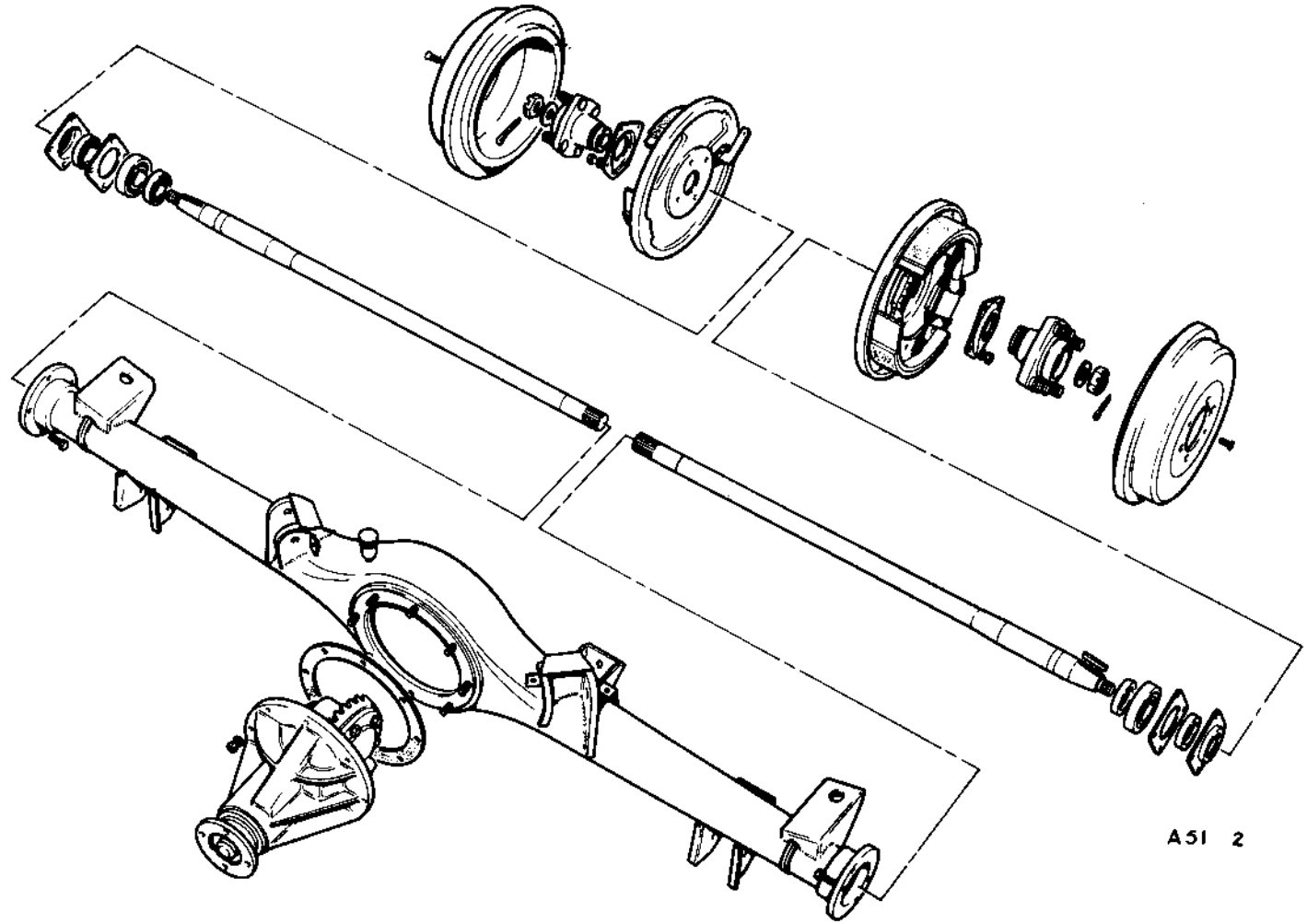

A51 2

**HALF SHAFT BEARING AND OUTER OIL SEAL**

Remove and refit 51.10.02

Service Tools: 18G 284 AR and 284

**Removing**

- 1 Jack up the rear of the car and support securely.
- 2 Remove the half shaft. 51.10.12
- 3 Using a drill, bore the retaining collar to weaken it.  
**CAUTION:** Do not allow the drill to penetrate the collar as damage will be caused to the half shaft.

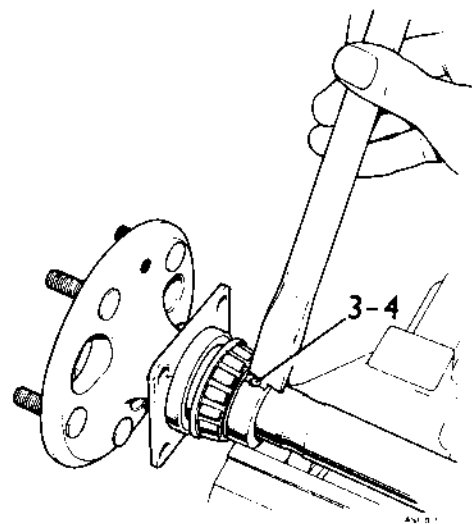

- 4 Using a hammer and chisel carefully burst the retaining collar and remove it from the half shaft.
- 5 Using a press remove the bearing, oil seal and retaining plate.
- 6 Using tools 18G 284 AR and 284 remove the half shaft bearing outer track from the axle casing.

**Refitting**

- 7 Fit the half shaft outer bearing track to the axle casing.
- 8 Fit the retaining plate to the half shaft (welded member adjacent to the shaft flange).
- 9 Lubricate the lip of the oil seal.
- 10 Slide the seal into position on the shaft.
- 11 Fit the bearing (tapered face of bearing towards the half shaft splines).
- 12 Wipe the shaft in front of the bearing clean of grease.
- 13 Smear the shaft in front of the bearing with Loctite 602 compound and also the bore of the new retaining collar.
- 14 Fit the new retaining collar and press the collar home until it butts against the bearing.

**CAUTION:** A force of not less than three tons should be required to slide the retaining collar into position over the last 0.125 in (3.175 mm) of its travel. If it is found that the interference fit of the collar is such that it can be fitted using a force of less than three tons the collar must be removed and another fitted.

- 15 Smear the bearing oil seal and the rear axle tube with a lithium base grease. See NOTE Operation No. 7 - 51.10.12.
- 16 Fit the half shaft. 51.10.12.
- 17 Lower the car.

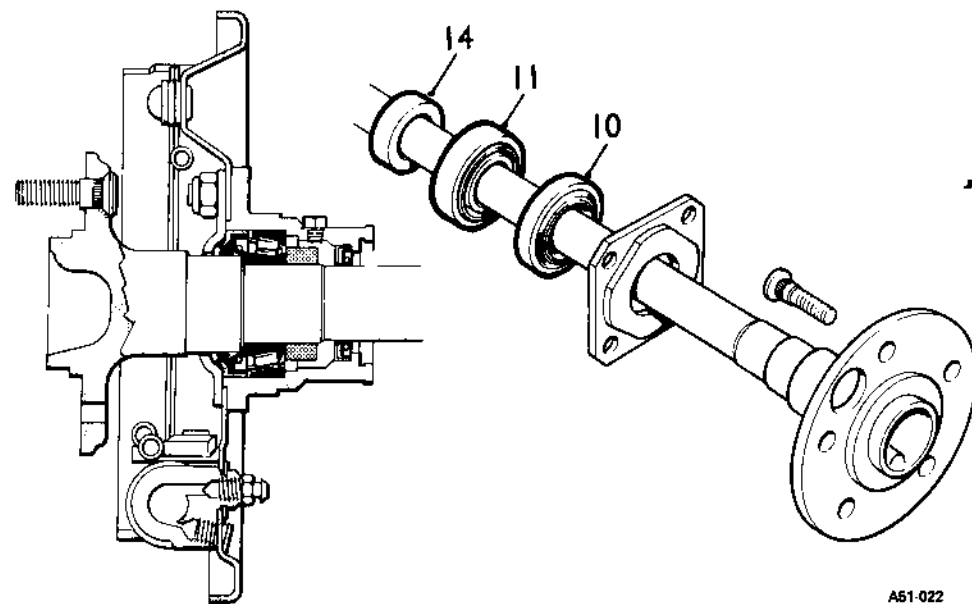

A51-022

**HALF SHAFT ASSEMBLY**

Remove and refit 51.10.12

Service Tools: 18G 284-1 and 284. (4235 or 3072 with S4235A-1 may be used in lieu of 284).

**Removing**

- 1 Jack up the rear of the car and support securely.
- 2 Remove the rear road wheel.
- 3 Release the handbrake and remove the brake drum.
- 4 Remove the four bolts and nuts securing the half shaft assembly and the back plate to the axle tube flange.
- 5 Using tools 18G 284-1 and 284 withdraw the half shaft.

**Refitting**

- 6 Smear the interior of the axle tube/half shaft bearing area with a lithium base grease.
- 7 Similarly grease the half shaft bearing and oil seal.

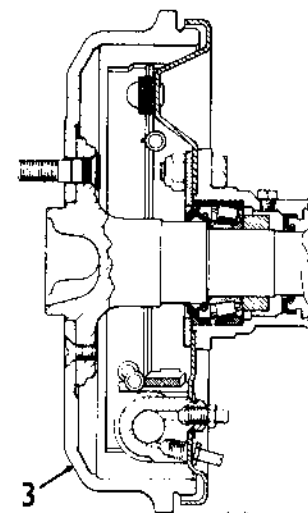

**NOTE:** On initial build, when lubricating the half shaft bearing using a grease-gun, the shaft should be rotated during the operation to ensure that the bearing is properly 'primed'.

On initial assembly, a total of 40 gms of grease must be used.

- 8 Enter the half shaft in the axle tube and engage the differential splines.
- 9 Carefully slide the half shaft into position. Ensure that the bearing and the oil seal enter the axle tube squarely.
- 10 Fit the four securing bolts and nuts. Tighten them evenly.
- 11 Carefully wipe off surplus grease to prevent contamination of the brake linings.
- 12 Fit the brake drum.
- 13 Fit the road wheel.
- 14 Lower the car.

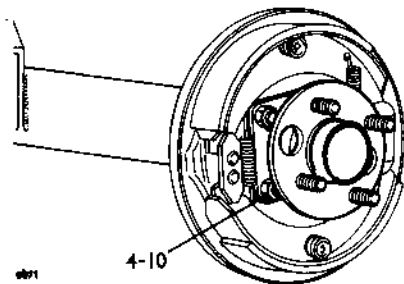

## HALF SHAFT INNER OIL SEAL

Remove and refit 51.10.14

Service Tool: 18G 1271

### Removing

- 1 Jack up the rear of the car and support securely.
- 2 Remove the half shaft assembly. 51.20.12.

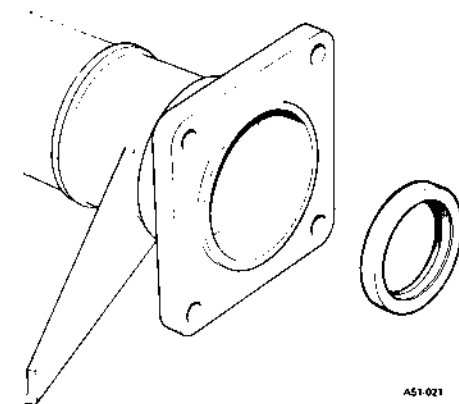

- 3 Remove the half shaft inner oil seal using tool 18G 1271

### Refitting

- 4 Evenly install a new half shaft inner oil seal in the axle casing (lip of seal towards differential).
- 5 Lubricate the seal lip.
- 6 Fit the half shaft assembly.
- 7 Lower the car.

## DIFFERENTIAL ASSEMBLY

Overhaul 51.15.07

Service Tools: S101, S101-1, 47, S4221A-16, 18G 191, 18G 191M, S98A, 18G 47AJ, 18G 1272, 6312, 18G 1273

- 1 Remove the rear axle assembly from the car. 51.25.01.
- 2 Remove the brake pipes.
- 3 Support the axle on stands.

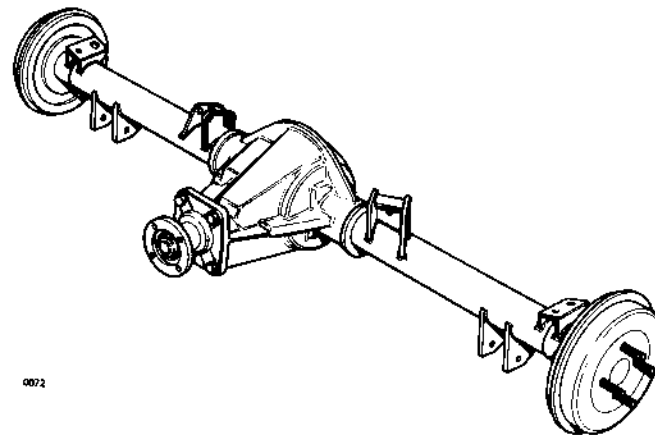

### Dismantling

- 4 Remove the differential rear cover and drain the oil.
- 5 Remove the half shafts and brake backplates. 51.10.12.
- 6 Remove the nyloc nut securing the drive flange and remove the flange.
- 7 Remove the four bolts securing the pinion oil seal housing to the axle case.

### Crown wheel differential unit

- 8 Check or mark the carrier bearing caps to establish original locations. Bearing caps must not be interchanged.
- 9 Remove the four bolts securing the bearing caps.
- 10 Remove the bearing caps.
- 11 Carefully lever the crown wheel and differential unit clear of the axle casing. If difficulty is experienced a spreader, tool S101 and S101-1 should be employed.
- 12 Lift out the crown wheel and differential unit complete with carrier bearings and shims.

*continued*

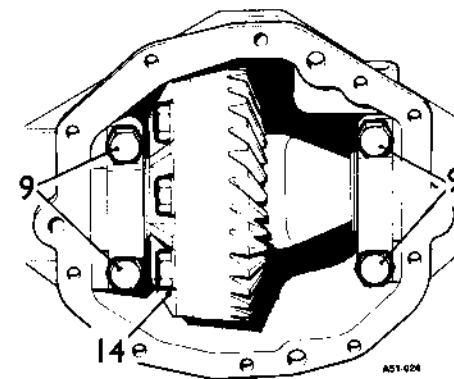

- 13 Using press 47 and adaptors S4221A-16 withdraw the carrier bearings.
- 14 Remove the eight bolts securing the crown wheel to the carrier flange and withdraw the crown wheel.
- 15 Withdraw the ball locating the differential pinion pin.
- 16 Remove the differential pinion pin.
- 17 Rotate the differential sun wheels to bring the two planet wheels and their respective thrust washers clear of the casing.
- 18 Remove the planet wheels and thrust washers.
- 19 Remove the two sun wheels and thrust washers.

**Pinion and Bearings**

- 20 Using tools 18G 1272 and S98A remove the pinion shaft nut.
- 21 Using a hardwood block carefully tap out the pinion complete with selective spacer, pinion head bearing and collapsible spacer.
- 22 Remove the pinion outer bearing from the axle casing.
- 23 Evenly drift out the pinion inner and outer bearing tracks from the axle casing. Care must be taken not to damage the axle casing.
- 24 Remove the collapsible spacer from the pinion shaft.
- 25 Using tool 47 and adaptor 18G 47AJ remove the pinion head bearing and spacer.

**Assembling**

**Crown Wheel and Differential Unit**

- 26 Fit the carrier bearings to the differential unit.
- 27 Lightly lubricate the carrier bearings, fit the bearing outer tracks and place the differential unit in the axle casing.
- 28 Slide the differential unit to one side of the axle casing and rotate the unit to allow the bearings to centralise.
- 29 Using a dial gauge check the crown wheel mounting flange for 'run-out'. 'Run-out' should not exceed 0.003 in (0.08 mm). Ensure that the bearing tracks are properly seated. When satisfied that 'run-out' is correct proceed as follows:

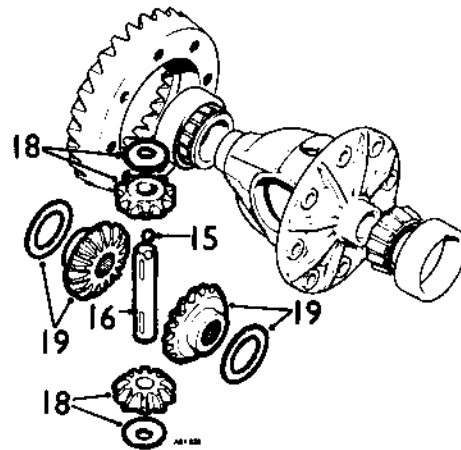

- 30 With the differential unit and bearings pressed to one side of axle casing note the reading on the dial gauge.
- 31 Slide the differential unit and bearings to the other side of the casing. Note this lateral travel registered on the dial gauge. Record this lateral travel (dimension 'A') as it is subsequently used to determine the shim pack required for the carrier bearings. **CAUTION:** The lateral travel in some cases may be found to be restricted due to a foul condition between the axle case and the short side of the differential unit. In the event of this, a nominal shim should be used between the case and the bearing on the short side of the differential unit. The value of this shim should be added to the gauge reading to give the lateral travel.
- 32 Remove the differential complete with bearings.
- 33 Lightly lubricate the sun wheel thrust washers and install the sun wheel and thrust washers in the differential unit.
- 34 Mesh the planet wheels with the sun wheels ensuring that the planet wheels are diametrically opposite. Rotate the sun wheels to bring the planet wheels into position in the differential unit casing.

- 35 Fit the differential pinion pin.
- 36 Check and assess planet wheel end-float.
- 37 Remove the pinion pin and rotate both sun wheels to bring the planet wheels clear of the differential unit casing.
- 38 Lubricate the planet wheel thrust washers selected and slide the planet wheels and thrust washers into position. Fit the pinion pin ensuring that the groove aligns with the location for the retaining ball and again check the planet gears for backlash and end-float. Zero backlash is required. Choose thrust washers as necessary from the selection available.
- 39 Fit the crown wheel and the ball retaining the pinion pin.
- 40 Smear the threads of the crown wheel securing bolts with 'Locquic T' grade primer and 'Loctite 601' compound. Fit the bolts and evenly tighten. (See Torque Wrench Settings.)

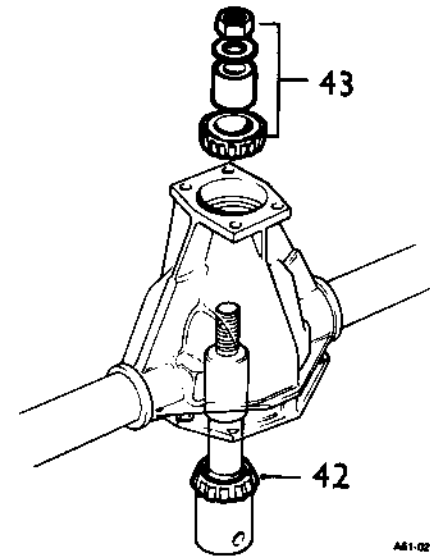

**Pinion and Bearings**

- 41 Fit the pinion shaft inner and outer bearing tracks to the axle casing.
- 42 Fit the pinion inner bearing to the dummy pinion 18G 191-1. **NOTE:** The dimension of the dummy pinion incorporates a built-in allowance for the maximum pinion head bearing spacer available, 0.0492 in (1.25 mm).
- 43 Lightly lubricate the bearings and fit the dummy pinion, bearings, spacer, washer and nut.
- 44 Tighten the dummy pinion nut until a bearing pre-load of 15 to 18 lbf in (0.17 to 0.21 kgf m) is obtained. This can be checked using a lbf in (kgf m) scale torque wrench and a socket.
- 45 Mount a dial gauge (tool 18G 191) on the dummy pinion and zero the gauge using the dummy pinion head as a base.
- 46 Move the gauge stylus over the centre of one carrier bearing bore. Note the indicated measurement. Repeat for the opposite carrier bearing bore.
- 47 Add the two measurements and divide by two.

- 48 Remove the gauge and dummy pinion.
- 49 Calculating the spacer required for the pinion head bearing.
 

**Example:**

$$\begin{aligned} &\text{Sum of carrier bearing bore readings} \\ &= 0.002 \text{ in (0.051 mm)} + 0.002 \text{ in} \\ &\quad \text{(0.051 mm)} \\ &= 0.004 \text{ in (0.102 mm)} \\ &\text{Divide by two} \\ &= \frac{0.004 \text{ in (0.102 mm)}}{2} = 0.002 \text{ in} \\ &\quad \text{(0.051 mm)} \end{aligned}$$

Add dummy pinion spacer allowance.

$$\begin{aligned} &0.049 \text{ in (1.25 mm)} \text{ (Inbuilt in dummy} \\ &\text{pinion dimensions)} \\ &= 0.002 \text{ in (0.051 mm)} + 0.049 \text{ in} \\ &\quad \text{(1.25 mm)} \\ &= 0.051 \text{ in (1.301 mm)} \end{aligned}$$

Examine the markings on the pinion head. Three markings will be found. These are:

  - X Identification for matched crown wheel/pinion set.

- Y Variation in pinion head thickness from nominal.
- Z This is a 'boxed' figure which indicates the variation from nominal setting to obtain the best running position. This dimension must be used when calculating the thickness of the pinion head spacer. If the 'boxed' figure Z is plus, subtract this value (+0.003 in) from the previous calculation. In the example 0.051 in (1.301 mm) - 0.003 in (0.076 mm) = 0.048 in (1.225 mm) = pinion head spacer required. If the 'boxed' figure Z is minus, add this value to the previous calculation. In the example 0.051 in (1.301 mm) + 0.003 in (0.076 mm) = 0.054 in (1.337 mm) = pinion head spacer required.

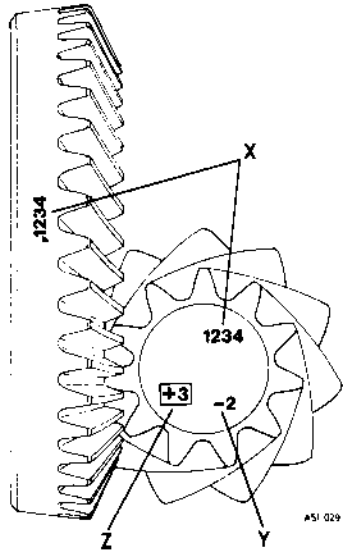

- 50 Fit a spacer of the required thickness to the pinion.
- 51 Fit the pinion head (inner) bearing to the pinion.
- 52 Fit a new collapsible spacer to the pinion and enter the pinion in the axle casing.

- 53 Fit the outer bearing, washer and nut.
- 54 Using tools 18G 1272 and S98 A carefully tighten the nut, periodically checking the torque required to rotate the pinion. Rotation torque should be within 13 to 20 lbf in (0.91 to 1.41 kgf m).
- IMPORTANT:** Should the nut be over-tightened so that a torque reading exceeding 20 lbf in (1.41 kgf m) is obtained it will be necessary to renew the collapsible spacer and repeat instructions 51 to 53. Under no circumstances must the nut be slackened to obtain the required torque.

#### Crown wheel and differential unit

- 55 Place the crown wheel and differential unit complete with outer bearing tracks into position in the axle casing.
- 56 Slide the unit towards the pinion until the crown wheel and pinion are fully meshed.
- 57 Zero a dial gauge on the rear (plain face) of the crown wheel ensuring that the crown wheel remains in contact with the pinion.
- 58 Slide the crown wheel and differential unit complete with bearings fully in the opposite direction. Note the reading indicated on the dial gauge. Call this dimension 'B'.

**CAUTION:** Refer to Caution in Operation Number 31.

- 59 To calculate the shim pack thickness required for each carrier bearing the following information is necessary:  
Required crown wheel/pinion backlash:

0.004 to 0.006 in (0.102 to 0.15 mm)  
Required carrier bearing pre-load  
0.002 to 0.004 in (0.051 to 0.102 mm)

Carrier bearing shims are available in 0.0016 in (0.04 mm) steps from 0.112 in (2.85 mm) to 0.136 in (3.45 mm).

- 60 Shim thickness required for carrier bearing on toothed side of crown wheel = Dimension 'A' (Instruction 31) minus Dimension 'B' (Instruction 58) plus

$\frac{\text{carrier bearing preload}}{2}$

2

#### Example:

Using the mean value of 0.003 in for carrier bearing pre-load and assumed values of 0.240 in for dimension 'A' the calculation is:

0.240 (dimension 'A') - 0.115 (dimension 'B')

$+\frac{0.003 \text{ (bearing pre-load)}}{2}$

$= 0.240 - 0.115 + 0.0015$   
 $= 0.1265 \text{ in (3.21 mm)} = \text{thickness of shims required.}$

- 61 Shim thickness required for carrier bearing on plain side of the crown wheel = Dimension 'B' (Instruction 58) minus crown wheel backlash

$+\frac{\text{plus carrier bearing pre-load}}{2}$

2

#### Example:

Using the mean values of 0.005 in for the crown wheel backlash, 0.003 in for carrier bearing pre-load and an assumed value of 0.115 in for dimension 'B' the calculation is:

0.115 (dimension 'B') - 0.005 (backlash)

$+\frac{0.003 \text{ (preload)}}{2}$

$= 0.115 - 0.005 + 0.0015$   
 $= 0.1115 \text{ in (2.8321 mm)} = \text{thickness of shim required.}$

In the example quoted the required shim thickness falls outside the shim

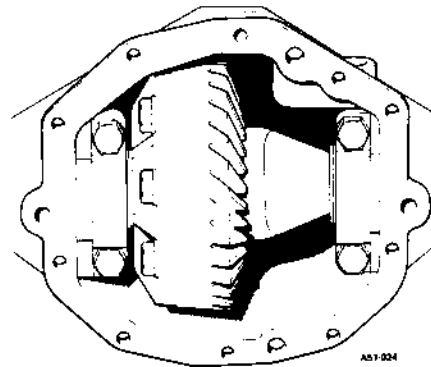

sizes available. The nearest shim thickness is 0.112 in (2.85 mm). It is thus thicker by 0.0005 in (0.028 mm) than the calculated requirement. Since the calculation was made using the mean values for backlash and bearing pre-load and the increased thickness of the shim available falls within the tolerance specified (Instruction 60) the 0.112 in (2.85 mm) shim is acceptable.

- 62 Allocate the selected shims to their respective carrier bearings. Ensure the shims are not interchanged.
- 63 Fit the spreading tool S101 and S101-1 to the axle casing.
- 64 Carefully expand the spreading tool to allow the crown wheel/differential unit to be placed in position complete with carrier bearing shims. Do not expand more than is necessary or irreparable damage will be caused to the axle casing. Do not exceed a stretch exceeding three or four flats of a finger tight turnbuckle. Do not lever against the spreader.

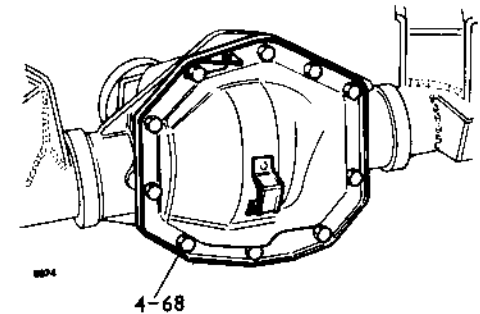

- 65 Remove the spreading tool.
- 66 Fit the carrier bearing caps to their original marked position and the four securing bolts. Evenly tighten the bolts—see 'TORQUE WRENCH SETTINGS'.

continued

- 67 Check crown wheel/pinion backlash.
- 68 Fit the rear cover and gasket to the axle casing.
- 69 Fit the halfshafts and backplate assemblies, 51.10.12.

**Pinion oil seal housing**

- 70 Remove the old oil seal from the pinion seal housing and fit a new seal (tool 6312, seal lip facing away from the front face of the seal housing).
- 71 Using a strip of masking tape place it over the machined step on the pinion shaft as illustrated. This protects the seal when the housing is eased into position. Apply the tape marginally to facilitate tape removal.
- 72 Lubricate the seal lip and masking tape.
- 73 Enter the seal housing in the axle casing and tap gently into position. Remove the masking tape.
- 74 Fit the brake pipes.
- 75 Fill the axle to the level of the filler plug with fresh oil.
- 76 Fit the axle to the car. 51.25.01
- 77 Bleed the brakes.
- 78 Lower the car.

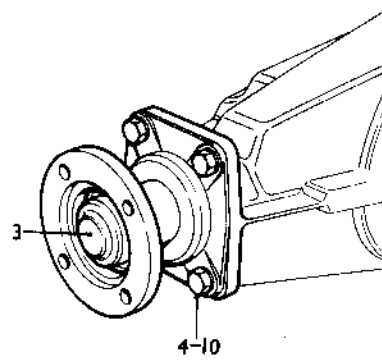

- 7 Wrap a narrow strip of masking tape over the machined step on the pinion shaft. This prevents damage to the seal when fitting. Apply the tape marginally to facilitate tape removal.
- 8 Lubricate the seal lip and the masking tape.

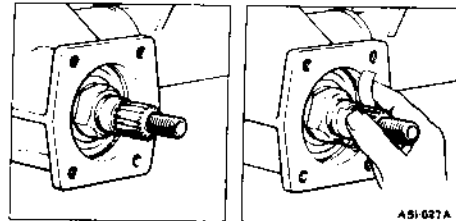

- 9 Fit the seal and housing, evenly entering the housing in the axle casing. Gently and evenly tap into position.
- 10 Fit and tighten the four bolts and spring washers securing the pinion oil seal housing to the axle case.
- 11 Refit the flange and nyloc nut and washer.
- 12 Tighten the flange nut.
- 13 Refit and tighten the rear propshaft coupling bolts.
- 14 Lower the vehicle.
- 15 Check the oil level.

**REAR AXLE ASSEMBLY**

Remove and refit 51.25.01

**Removing**

- 1 Jack up the rear of the vehicle and support the body securely on two stands.
- 2 Remove the rear wheels and release the handbrake.
- 3 Co-relate the drive flanges and remove the four rear propshaft securing nuts and bolts.
- 4 Fit a brake pipe clamp to the flexible brake hose.
- 5 Undo the fixed brake pipe and union nut and displace the flexible hose from the axle.

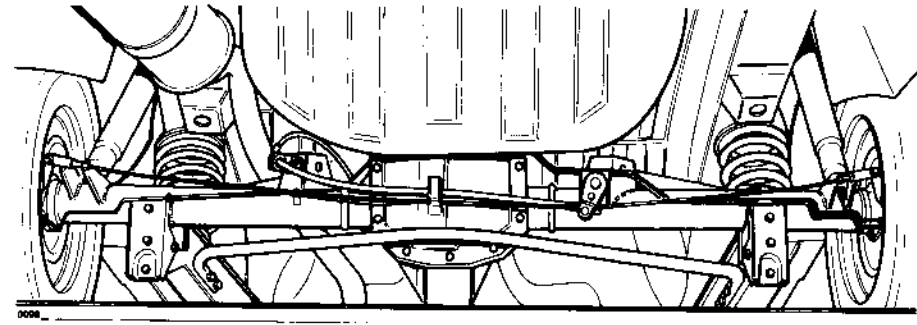
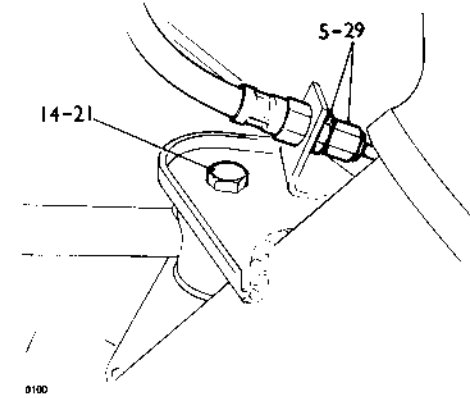

- 6 Remove the split pins and clevis pin from the handbrake cable clevis forks.
- 7 Slacken the compensator pinch bolt.
- 8 Remove the compensator trunion.
- 9 Feed the handbrake cables through the rear bracket on the axle.
- 10 Support the axle on a jack.
- 11 Disconnect the rear dampers from their lower fixing brackets.

- 12 Lower the axle on the jack.
- 13 Remove the rear road springs.
- 14 Remove the nuts and bolts securing the radius arms to the axle.
- 15 Displace the handbrake cables and bracket to one side.
- 16 Remove the nuts and bolts securing the trailing arms to the axle.
- 17 Manoeuvre the axle over the anti-roll bar and clear of the vehicle.

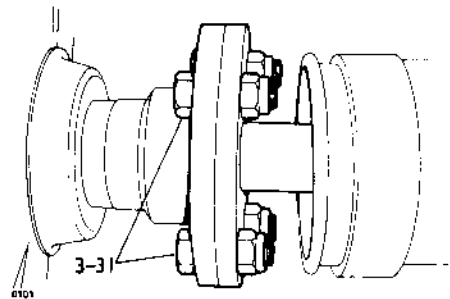

**Refitting**

- 18 Position the jack and manoeuvre the axle into position over the anti-roll bar.

- 19 Grease all bushes with rubber grease.
- 20 Refit and tighten the trailing arm securing bolts and nuts.
- 21 Reposition the handbrake cable bracket and refit and tighten the radius arm securing bolts and nuts.
- 22 Refit the rear road springs.
- 23 Jack up the axle and locate the dampers in their lower fixing brackets.
- 24 Fit the damper rubbers and washers and tighten the securing nuts and lock nuts.
- 25 Lower the jack.

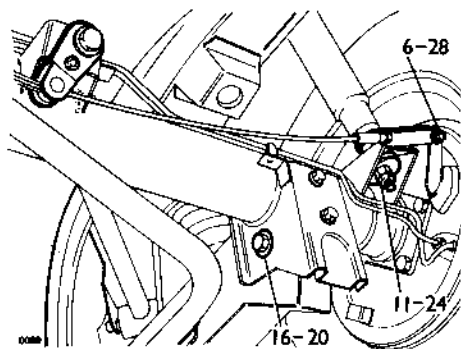

- 26 Feed the handbrake cables through the rear bracket and refit the compensator trunion.
- 27 Tighten the pinch bolt.
- 28 Connect the handbrake cable clevis forks, pins and split pins.
- 29 Refit the flexible brake hose to the axle and connect the fixed brake pipe.
- 30 Remove the brake pipe clamp.
- 31 Refit the propshaft and tighten the four nuts and bolts.
- 32 Bleed the brakes.
- 33 Refit the rear wheels.
- 34 Remove the stands and lower the rear of the vehicle.
- 35 Check the axle oil level.

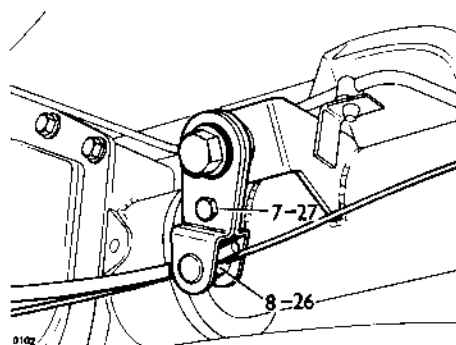

## TORQUE FIGURES FOR REAR AXLE

	<i>Nm</i>	<i>lbf ft</i>
Rear cover to axle case	22-28	16-21
Pinion oil seal housing to axle case	40-50	30-37
Differential unit bearing caps to axle case	80-100	60-75
Crown wheel to differential unit (with loctite)	108-122	80-90
Pinion Flange to pinion	120-160	90-120
Axle shafts/back-plates to axle casing	40-60	35-40
Oil capacity	1.60 pts	0.91 litres

Loctite specification - axle shaft collars and crown wheel bolts

Hub grease - as specification SD 1

**STEERING RACK AND PINION****Remove and refit****57.25.01****Removing**

- 1 Drive the vehicle onto a ramp.
- 2 Set the road wheels to the straight-ahead position.
- 3 Raise the ramp.
- 4 Scribe the pinion shaft and the lower steering coupling to ensure original spline location on refitting.  
**NOTE:** This instruction applies only if the pinion and rack are not to be dismantled.
- 5 Disconnect the rack tie-rod outer ball joints from the steering arms.
- 6 Remove the pinch bolt securing the steering coupling to the rack pinion.
- 7 Remove the two bolts, spring washers and plain washers securing the pinion end of the rack to the sub-frame.
- 8 Remove the two nyloc nuts and plain washers, and withdraw the bolts securing the rack to the sub-frame.
- 9 Disconnect the lower coupling from the pinion shaft.
- 10 Withdraw the rack from the driver's side.

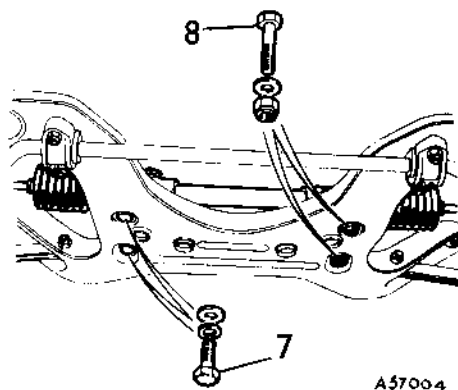
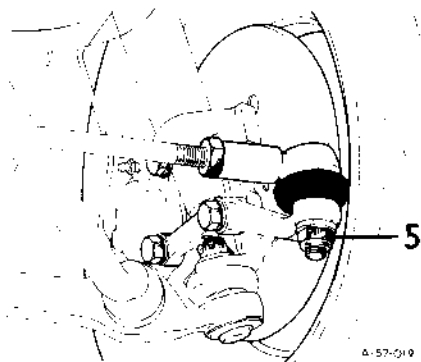
**Refitting**

- 11 Locate the rack on the sub-frame from the driver's side. With the steering-wheel in the straight-ahead position, align the previously scribed markings and engage the pinion shaft into the lower coupling;  
or  
If no scribe lines were made, or the rack and pinion were dismantled, it is advised that the rack shaft is centralized before beginning installation on the car. Remove the centre plug from the thrust pad and using a length of stiff wire (e.g. welding rod), locate the dimple in the rack shaft. When the dimple is aligned with the wire, the rack shaft is centred. Fit a bolt to the pinion plug and gently tighten until the pinion shaft is pinched. This will hold the rack shaft in its centred position. The rack assembly can now be offered to the sub-frame.

- 12 Secure the rack to the sub-frame with the bolts, washers and nyloc nuts.
- 13 Fit the tie-rod outer ball joints to the steering-arms.
- 14 Fit and tighten the pinion coupling pinch bolt.
- 15 Remove the locating bolt used to temporarily lock the pinion shaft, and fit the centre plug.
- 16 Lower the ramp.
- 17 Check and adjust the front wheel track as necessary, see 57.65.01.

**STEERING RACK GAITERS****Remove and refit****57.25.02****Removing**

- 1 Slacken the locknut securing both tie-rod outer ball joints.
- 2 Remove the nut and washer securing the tie-rod outer ball joint to the steering-arm.
- 3 Release the ball joint from the steering-arm.
- 4 Unscrew the ball joint from the tie-rod and remove the retaining locknut.
- 5 Remove the inner and outer clips retaining the gaiter to the rack and tie-rod respectively.
- 6 Withdraw the gaiter.
- 7 Repeat instructions 2 to 6 on the opposite tie-rod.

**Refitting**

- 8 Lubricate the tie-rod inner ball joint with fresh grease.

- 9 Slide the new gaiter along the tie-rod into position on the rack.
- 10 With the rack centralized, fit the inner clip to the gaiter and rack housing.
- 11 Position the outer end of the gaiter on the tie-rod so that it is capable of accommodating movement of the tie-rod from lock to lock.
- 12 Secure the outer end of the gaiter to the tie-rod end with the clip.
- 13 Fit the locknut to the tie-rod, locating it as near as possible to its original location.
- 14 Fit the outer ball joint to the tie-rod.
- 15 Connect the tie-rod outer ball joint to the steering-arm and secure it with the plain washer and nut.
- 16 Repeat instructions 8 to 15 on the opposite tie-rod.
- 17 Check, and re-set the front wheel track as necessary.
- 18 Tighten the locknut securing the tie-rod outer ball joint.

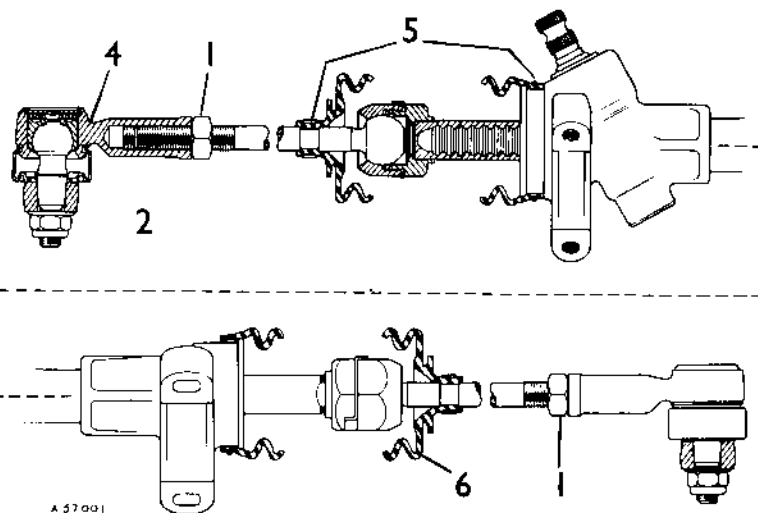



## STEERING RACK AND PINION

Overhaul 57.25.07

Special tool: 18G 1261

### Dismantling

1 Remove the rack, see 57.25.01.

### Rack damper

- 2 Remove the plug securing the damper assembly to the rack housing.
- 3 Withdraw the spring, shim(s) and damper.

### Pinion

- 4 Remove the rubber seal.
- 5 Remove the pinion retaining plug using the special tool 18G 1261.
- 6 Withdraw the pinion and bearing from the rack housing.
- 7 Remove the circlip securing the ball race to the pinion shaft and withdraw the ball race.

### Tie-rods and rack shaft

- 8 Release the clips and tie-wires securing the gaiters to the rack housing and the tie-rods, and slide the gaiter clear of the rack.
- 9 Slide the pinion end of the rack housing towards its adjacent tie-rod inner ball joint.
- 10 Grip the exposed rack shaft in protected vice jaws.
- 11 Unscrew the tie-rod inner ball joint assemblies from both ends of the rack shaft.
- 12 Withdraw the rack shaft.

### Rack housing bush

- 13 Using a suitable drift, remove the bush from the rack housing.

### Reassembling

#### Rack housing bush

- 14 Fit a new bush to the rack housing.

#### Rack shaft and tie-rods

- 15 Hold the plain (toothless) portion of the rack shaft in protected vice jaws.
- 16 Fit the tie-rod inner ball joint assembly to the rack shaft, tighten to 35 to 45 lbf ft (4.84 to 6.22 kgf m), and deform the collar to secure the ball joint housing to the rack shaft.

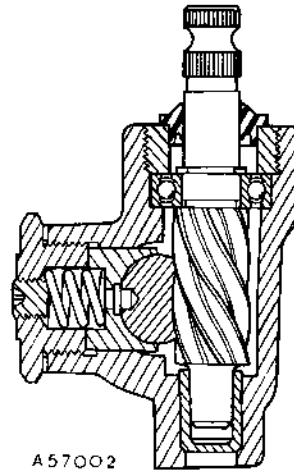

A57002

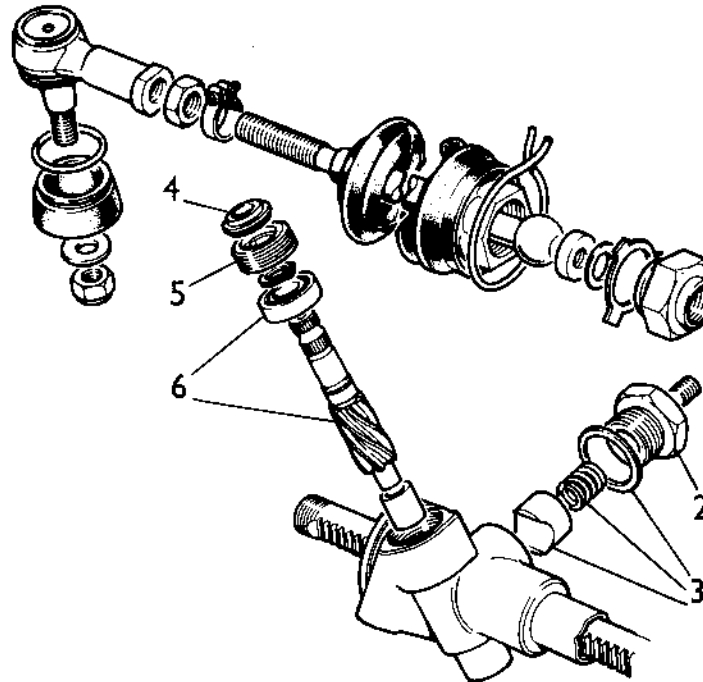

A57005

- 17 Fit the rack shaft into the housing, ensuring that the toothed end of the shaft is located at the pinion housing.
- 18 Fit the tie-rod assembly to the pinion end of the rack shaft – refer to operation 15.

### Pinion

- 19 Fit the ball race to the pinion and secure it with the circlip. Fit the rubber seal.
- 20 Position the rack shaft teeth to permit pinion entry and engage the rack with the pinion.
- 21 Lubricate the pinion shaft, refit and tighten the end plug.
- 22 Pack the ends of the rack shafts and tie-rod inner ball joints with clean grease.
- 23 Fit and secure the gaiters.
- 24 Fit the rack damper, see 57.35.10.
- 25 Fit the rack to the car, see 57.25.01.

## STEERING RACK DAMPER

Adjust 57.35.09

- 1 Remove the rack, see 57.25.01.
- 2 Locate the rack shaft in mid-position.
- 3 Remove the centre plug from the damper plug and insert a stylus or dial gauge and check the rack shaft for side movement (90° to shaft axis). Side movement should be within 0.001 to 0.007 in (0.03 to 0.18 mm).
- 4 Adjust if necessary by removing the damper plug and adding or subtracting shim(s) as required;  
or  
4a In the absence of a dial gauge, remove the damper plug and shims.  
4b Remove the shims and spring and replace the damper plug.  
4c Gently tighten the damper plug until the plunger grips the rack eliminating all side-play.  
4d With feeler gauges inserted between the rack pinion housing and the underside of the damper plug flange, check the clearance existing.  
4e To the thickness of the feeler gauge pack, add the rack side movement required, 0.001 to 0.007 in (0.03 to 0.18 mm). This gives the thickness of the shims to be fitted under the damper plug flange.  
4f Remove the damper plug and fit the required shim pack. Tighten the damper plug to 45 to 60 lbf ft (6.22 to 8.30 kgf m).
- 5 Refit the rack, see 57.25.01.

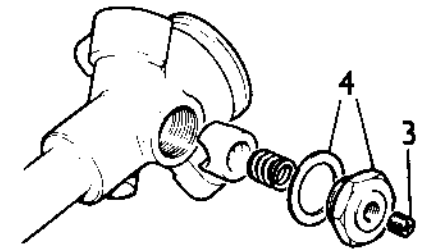

A57006

**STEERING RACK DAMPER**

Remove and refit 57.35.10

**Removing**

- 1 Remove the rack, see 57.25.01.
- 2 Remove the clip and tie-wire securing the gaiter at the pinion end of the rack and slide the gaiter along the tie-rod to expose the rack shaft.
- 3 Unscrew and remove the damper plug and shims.
- 4 Withdraw the spring and plunger.

**Refitting**

- 5 Locate the rack shaft in mid-position.
- 6 Fit the plunger and spring.
- 7 Check, and adjust the rack shaft side movement as required (instructions 4 to 6, operation 57.35.09).
- 8 Refit the rack, see 57.25.01.

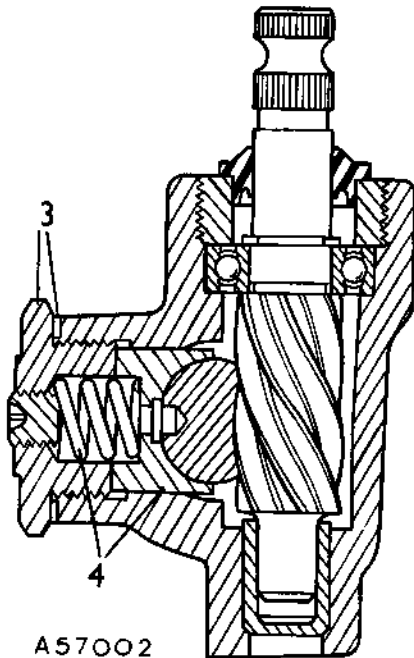
**STEERING-COLUMN ASSEMBLY**

Remove and refit 57.40.01

**Removing**

- 1 Open the bonnet and disconnect the battery.
- 2 Remove the pinch bolt securing the upper universal coupling to the steering mast.
- 3 Remove the cleat securing the electrical harness to the steering-column.
- 4 Disconnect the plug-in connectors (4) for the ignition/starter, horn/trafficator/lights and windscreen wiper/washer switches.
- 5 Remove the two screws securing the nacelle to the steering-column. Remove the nacelle.
- 6 Using a centre-punch, mark the centre of the two shear-head bolts securing the column housing to the body.
- 7 Using a small chisel, unscrew the shear-head bolts;
  - or
  - a If instruction 7 proves to be unsuccessful drill into the shear-head bolts where previously marked by the centre punch and unscrew using an Easiout extractor.
- 8 With the road wheels in the straight-ahead position, withdraw the steering-column assembly, noting the positions of the flat and wavy washers.

**Refitting**

- 9 Enter the steering-column in the lower bush. Ensure that the flat and wavy washers are in position.
- 10 With the road wheels in the straight-ahead position and the steering-wheel centralized, engage the steering-column splines in the upper universal coupling.
- 11 Fit and tighten the pinch bolt.
- 12 Locate the steering-column on the body and align the mounting holes.
- 13 Fit two new shear-head bolts and tighten evenly until both heads shear.

- 14 Re-connect the plug in connectors and secure the electrical harness to the steering-column housing with the plastic cleat.
- 15 Fit the nacelle and secure with the two screws.
- 16 Connect the battery.

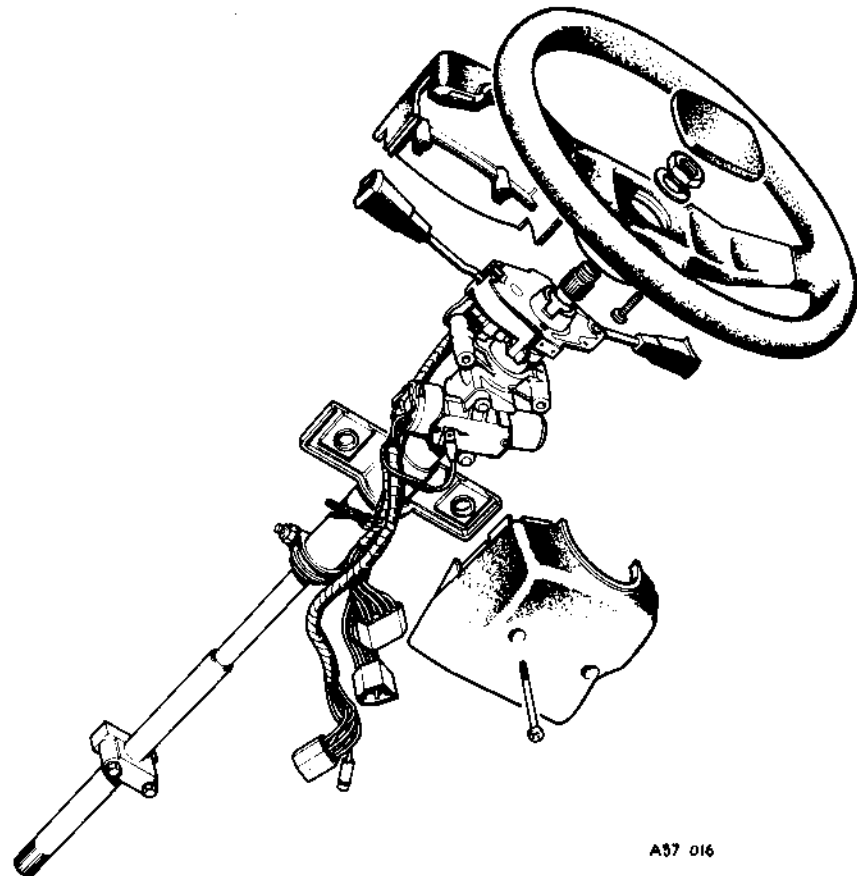

## STEERING COLUMN ASSEMBLY

Overhaul 57.40.10

### Dismantling

- 1 Remove the steering-column assembly from the car, see 57.40.01.
- 2 Remove the steering-wheel centre cover.
- 3 Slacken and remove the nut and washer securing the steering-wheel hub to the steering-column.
- 4 Using a suitable extractor, remove the steering-wheel.
- 5 Slacken the clamping screw and withdraw the steering-column multi-purpose switch assembly from the column.
- 6 Using a centre-punch, mark the centre of the two shear-head bolts securing the steering lock to the column housing.
- 7 Using a small chisel, unscrew the shear head bolts;  
or
  - a If instruction 7 proves to be unsuccessful, drill into the shear-head bolts where previously marked by the centre-punch and unscrew using an Easiout extractor.
- 8 Withdraw the column housing off the steering mast.

- 9 Remove the nut and bolt securing the clamp to the steering mast. Remove the clamp.
- 10 Using a suitable drift, remove the top and bottom bushes from the steering-column housing.

### Reassembling

- 11 Align the slots in the bushes with the lugs in the column housing. Press in the bushes.
- 12 Fit the clamp to the steering mast. Fit and tighten the pinch bolt.
- 13 Fit the steering mast into the housing.
- 14 Fit the steering lock to the column housing and secure with two new shear-head bolts. Evenly tighten the bolts until the heads shear off.
- 15 Fit the multi-purpose switch assembly to the column housing and secure by tightening the clamp screw.
- 16 Align the arrow on the trafficator cancelling collar with the centre of the trafficator stalk.
- 17 Align the lugs of the steering-wheel with the cut-outs in the cancelling cam. Fit the steering-wheel.
- 18 Fit and tighten the plain washer and nut securing the steering-wheel hub to the steering-column.
- 19 Fit the steering-wheel centre cover.
- 20 Fit the steering-column assembly to the car, see 57.40.01.

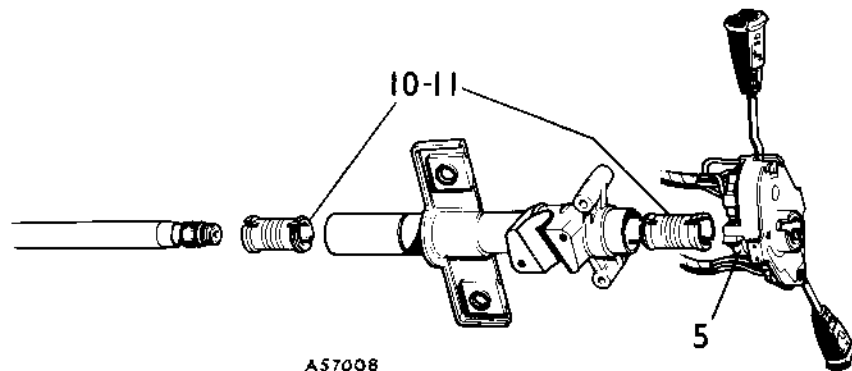

## INTERMEDIATE SHAFT

Remove and refit 57.40.22

### Removing

- 1 Remove the pinch bolt securing the intermediate shaft to the upper universal coupling.
- 2 Remove the pinch bolt securing the intermediate shaft universal joint to the rack pinion.
- 3 Set the road wheels to the straight-ahead position.
- 4 Slide the intermediate shaft upwards to disengage the universal joint from the pinion shaft.
- 5 Withdraw the intermediate shaft downwards and disengage from the upper universal coupling.

### Refitting

- 6 Engage the splines of the intermediate shaft in the upper universal coupling.
- 7 Ensure that the steering-wheel is in the straight-ahead position and engage the intermediate shaft universal joint in the splines of the rack pinion.
- 8 Fit and tighten the two pinch bolts.

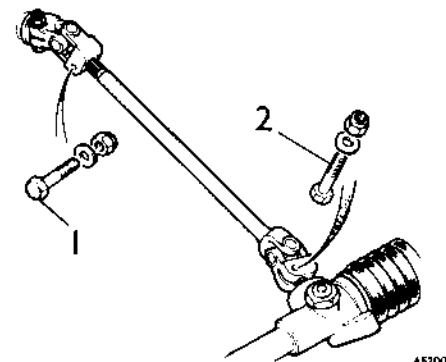

## STEERING-COLUMN UPPER UNIVERSAL COUPLING

Remove and refit 57.40.26

### Removing

- 1 Slacken the pinch bolt securing the upper universal coupling to the steering mast.
- 2 Remove the pinch bolt securing the upper universal coupling to the intermediate shaft.
- 3 Turn the steering-wheel to facilitate the removal of the top pinch bolt.
- 4 Set the road wheels to the straight-ahead position.
- 5 Slide the upper universal coupling down the intermediate shaft and remove the two washers from the steering mast (noting position for reassembly).
- 6 Remove the upper universal coupling from the intermediate shaft.

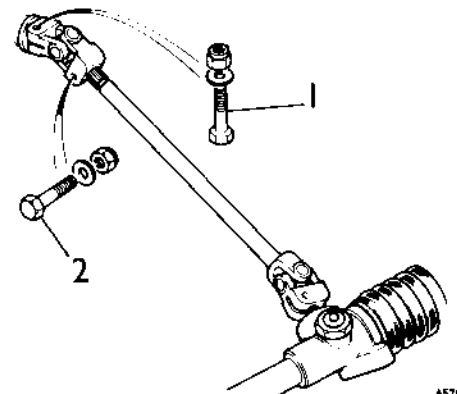

### Refitting

- 7 Engage the upper universal coupling in the splines of the intermediate shaft.
- 8 Fit the two washers to the steering mast.
- 9 Ensuring that the steering-wheel and the road wheels are in the straight-ahead position, engage the coupling in the splines of the steering mast.
- 10 Fit and tighten the two pinch bolts.

### STEERING-COLUMN NACELLE

Remove and refit 57.40.29

#### Removing

- 1 Withdraw the key from the steering lock/ignition switch.
- 2 Remove the two screws clamping the nacelle halves.
- 3 Remove the nacelle halves.

#### Refitting

- 4 Reverse instructions 1 to 3.

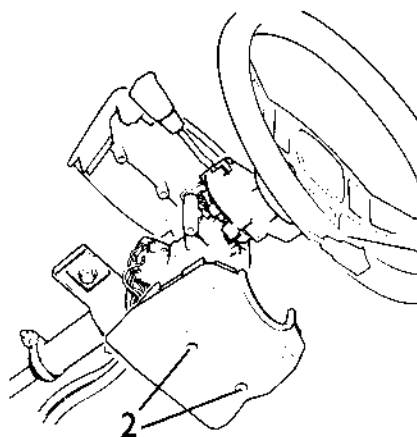

A57 017

### STEERING LOCK/IGNITION SWITCH

Remove and refit 57.40.31

#### Removing

- 1 Remove the nacelle, see 57.40.29.
- 2 Using a centre-punch, mark the centre of the two shear-head bolts securing the steering lock to the column.
- 3 Using a small chisel, unscrew the shear-head bolts;
  - or
  - a If instruction 3 proves to be unsuccessful, drill into the shear-head bolts where previously marked by the centre-punch, and unscrew using an Easiout extractor.
- 4 Disconnect the plug-in connector to the ignition switch.
- 5 Remove the steering lock.

#### Refitting

- 6 Locate the steering lock on the column and align the mounting holes.
- 7 Fit two new shear-head bolts. Evenly tighten until both heads shear.
- 8 Connect the plug-in connector for the ignition switch.
- 9 Fit the nacelle, see 57.40.29.

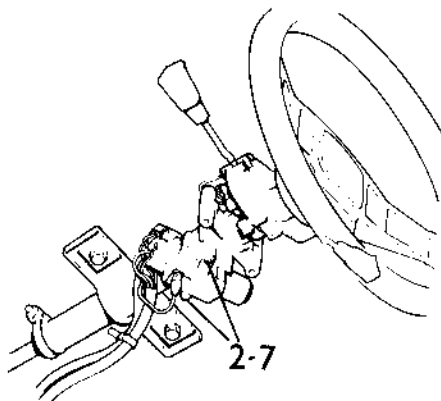

A57 018

### TIE-ROD BALL JOINT – OUTER

Remove and refit 57.55.02

#### Removing

- 1 Slacken the locknut securing the tie-rod to the outer ball joint.
- 2 Remove the nut and washer securing the ball joint to the steering-arm.
- 3 Release the ball joint from the steering-arm.
- 4 Unscrew the ball joint from the tie-rod.

#### Refitting

- 5 Screw the ball joint onto the tie-rod. (The distance between tie-rod ball joint centres [inner to outer] is 13 1/4 in (338 mm).)
- 6 Connect the ball joint to the steering-arm and secure with the washer and nut.
- 7 Check and adjust the front wheel track as necessary.
- 8 Tighten the tie-rod locknut.

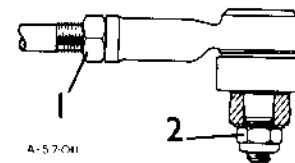

A-57 041

### TIE-ROD BALL JOINT – INNER

Remove and refit 57.55.03

#### Removing

- 1 Remove the tie-rod outer ball joint, see 57.55.02.
- 2 Release the wire and clip, and remove the gaiter from the inner ball joint to be renewed.
- 3 Release the tie-wire and clip, and slide the gaiter along the tie-rod at the opposite end of the rack.
- 4 Wipe the inner ball joints clean of grease.
- 5 Unscrew the tie-rod inner ball joint from the rack shaft. To prevent stress being applied to the rack pinion the opposite inner ball joint assembly should be held with a spanner.

#### Refitting

- 6 Fit the new inner tie-rod ball joint assembly to the rack shaft and tighten to 35 to 45 lbf ft (4.84 to 8.22 kgf m). To prevent stress being applied to the rack pinion the opposite inner ball joint assembly should be held with a spanner.

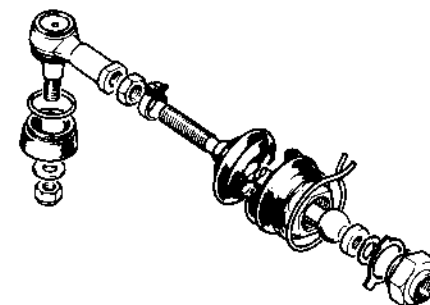

A67006

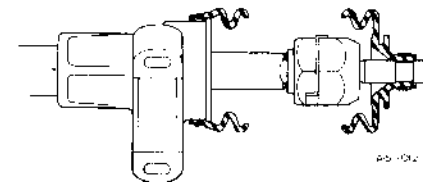

A67 004

- 7 Using a suitable drift, deform the lock collar to secure the inner ball joint assembly to the rack shaft.
- 8 Fit the gaiters, tie-wires and clips.
- 9 Fit the outer ball joint to the tie-rod, see 57.55.02.
- 10 Check and adjust the front wheel track as necessary.

## STEERING-WHEEL

Remove and refit 57.60.01

### Removing

- 1 Remove the steering-wheel centre cover.
- 2 Locate the road wheels in the straight-ahead position.
- 3 Slacken and remove the nut and washer securing the steering-wheel hub to the steering-column.
- 4 To ensure that the steering-wheel (hub) will be replaced in its original spline location, scribe both the hub centre and the top of the steering mast.
- 5 Using a suitable extractor, withdraw the steering-wheel. DO NOT attempt to drive or tap the steering-wheel from the mast.

### Refitting

- 6 Ensure that the arrow on the trafficator cancelling collar aligns with the centre of the trafficator stalk.  
Reverse instructions 1, 2, 3 and 5. If the steering-wheel was withdrawn without the spline location being marked, set the road wheels to the straight-ahead position and centralize the steering-wheel.

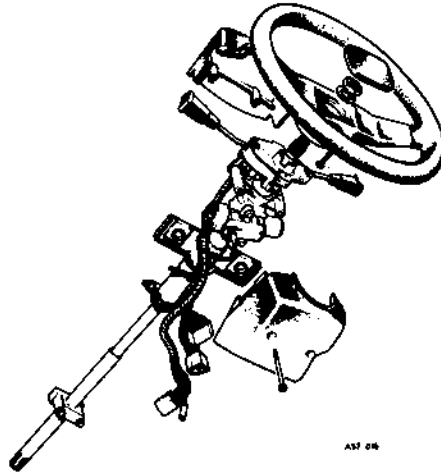

## STEERING GEOMETRY

Check 57.65.00

See 'GENERAL SPECIFICATION DATA'.

### FRONT WHEEL ALIGNMENT

Check and adjust 57.65.01

#### Checking

- 1 Locate the car on level ground and position the front wheels in the straight-ahead position.
- 2 Using wheel alignment equipment, check the front wheels for toe-in. Four requirements should be met:
  - a Centralized steering-wheel.
  - b Centralized steering-rack.
  - c Front wheels parallel to  $\frac{1}{8}$  in (1.59 mm) toe-in.
  - d Ball centres of both tie-rods equal.

#### Adjusting

- 3 Slacken the outer clips on the rack gaiters.
- 4 Slacken the locknut at the tie-rod outer ball joints.
- 5 Shorten or extend both tie-rods by an equal amount to obtain the required setting (0 to  $\frac{1}{8}$  in, 0 to 1.59 mm toe-in).
- 6 Tighten the locknuts at the tie-rod outer ball joints.
- 7 Tighten the gaiter clips.

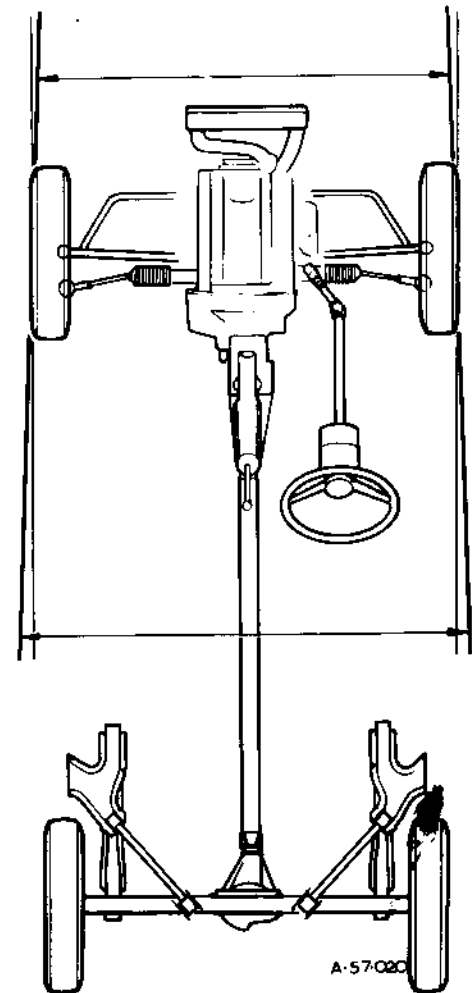

**ANTI-ROLL BAR**

Remove and refit 60.10.01

Bottom link rubbers  
— remove and refit 60.10.06

**Removing**

- 1 Raise the car and support securely.
- 2 Remove the bolts and nyloc nuts (two each side) securing the anti-roll bar brackets to the sub frame.
- 3 Remove the spring pin, nyloc nut, flat washer, dished washer and outer rubber bush, securing each end of the anti-roll bar to the bottom link.
- 4 Withdraw the anti-roll bar, adjusting the jacks as necessary to facilitate removal.
- 5 Remove the inner bush and dished washer from each end of the anti-roll bar.

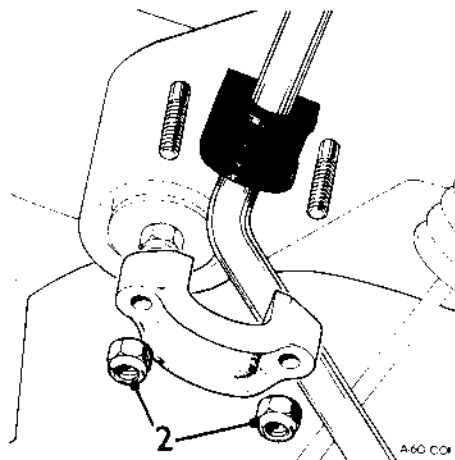
**Refitting**

- 6 Fit the inner dished washer (dish towards the bush) and the inner rubber bush to each end of the anti-roll bar.
- 7 Offer up the anti-roll bar and align the ends with the mounting holes in each of the bottom links.
- 8 Fit the outer rubber bush, dish washer, flat washer and nyloc nut to each end of the anti-roll bar.
- 9 Tighten to stop and fit the spring pin.
- 10 Position the mounting brackets and secure the anti-roll bar to the sub frame with the bolts and nyloc nuts.
- 11 Lower the car.

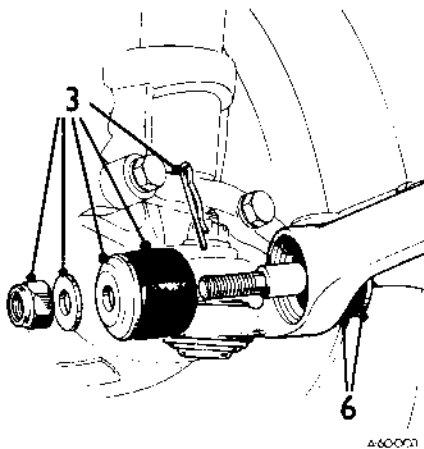
**ANTI-ROLL BAR MOUNTING RUBBERS**

Remove and refit 60.10.05

**Removing**

- 1 Raise the car and support securely.
- 2 Remove the anti-roll bar. 60.10.01.
- 3 Cut the old mounting bushes and remove them from the anti-roll bar.

**Refitting**

- 4 Ensure that the anti-roll bar is clean throughout its length.
- 5 Smear the anti-roll bar with the approved rubber grease.
- 6 Slide the new mounting bushes into position along the anti-roll bar.
- 7 Fit the anti-roll bar to the car. 60.10.01.
- 8 Lower the car.

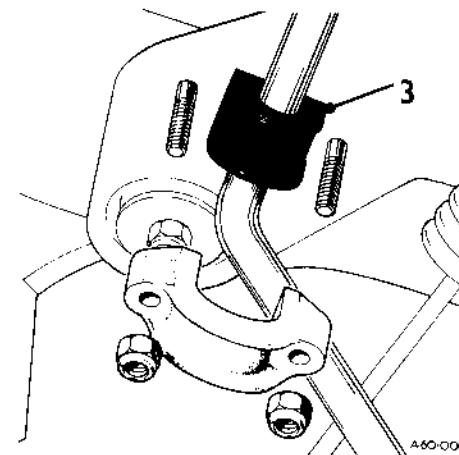
**BALL JOINT**

Remove and refit 60.15.03

**Removing**

- 1 Remove the bottom link. 60.40.02.
- 2 Remove the plastic boot from the ball joint.
- 3 Remove the circlip.
- 4 Press out the ball joint housing.

**Refitting**

- 5 Using a short length of suitable bore steel tubing, press a new ball joint and housing squarely into the bottom link. Do not apply pressure to the centre of the housing end cap.
- 6 Fit the circlip and plastic boot.
- 7 Fit the bottom link. 60.40.02.

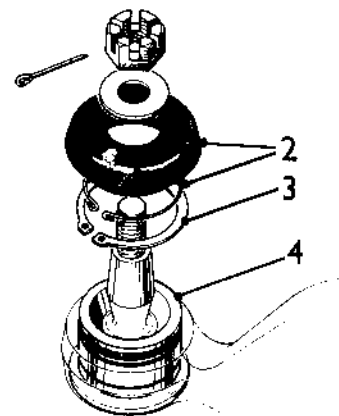

## FRONT ROAD SPRING

Remove and refit 60.20.01

Bump stop – remove and refit 60.30.10

Service tools: P.5045, RTR 360

### Removing

- 1 Jack up the car and support the body on stands.
- 2 Remove the road wheel.
- 3 Detach the steering arm from the stub axle assembly (two bolts).
- 4 Slacken the locknut securing the brake hose to the bracket on the damper tube.
- 5 Remove the remaining bolt securing the brake caliper to the stub axle

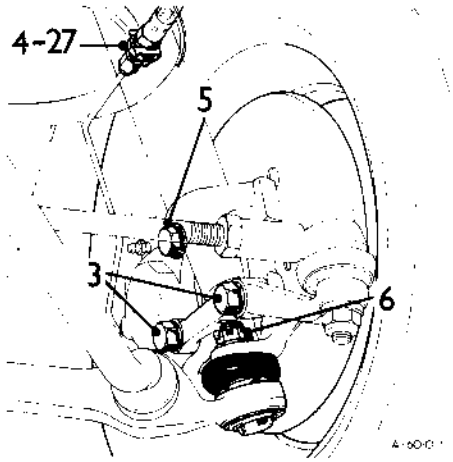

- 6 Remove the split pin, slotted nut and flat washer and release the ball joint from the stub axle assembly.
- 7 Remove the three nyloc nuts securing the damper and spring to the wing valance.
- 8 Pull the strut clear of the car.
- 9 Fit the two clamps P.5045 to the spring and compress coils evenly.
- 10 Remove the nut from the damper piston rod.
- 11 Lift off the spring pan complete with the top mounting and swivel assembly.
- 12 Withdraw the road spring from the damper strut.
- 13 Progressively slacken the spring clamps.

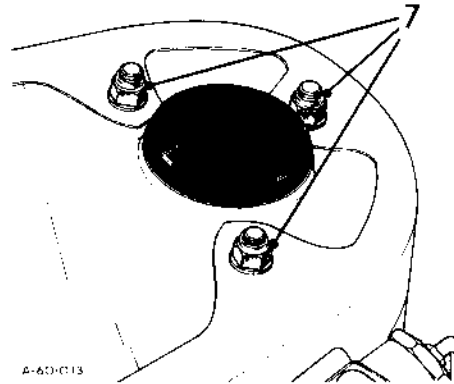

### Refitting

- 14 Using the clamps, P.5045 compress the road spring.
- 15 Ensure that the bump stop rubber is in position.
- 16 Extend fully the damper piston rod and fit the lower insulating ring, rubber gaiter, road spring, upper insulating ring and spring pan.
- 17 Fit the seal to the thrust collar and position on the upper spring pan.
- 18 Fit the large plain washer. (Ground surface facing spring pan.)
- 19 Fit the rubber mounting to the damper piston rod and secure with the dished washer and nut using the special tool RTR 360. Tighten to the correct torque.

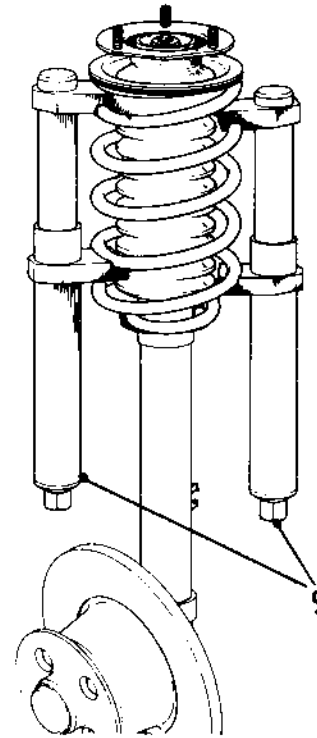

- 20 Slacken progressively the spring clamps, ensuring correct seating of the spring.
- 21 Ensure that the rubber gaiter is correctly fitted.
- 22 Thoroughly clean the spring turret and apply plasti-seal to the damper upper mounting flange.
- 23 Offer up the damper to the spring turret with the cut out facing outboard.
- 24 Engage the three studs, fit the plain washers, nyloc nuts and tighten.
- 25 Fit the ball joint into the stub axle assembly and secure with the flat washer, slotted nut and split pin.
- 26 Position the brake caliper onto the stub axle assembly and insert the upper bolt – do not tighten at this stage.
- 27 Position the brake pipe to the bracket on the damper tube.
- 28 Fit the steering arm to the stub axle assembly (the rear bolt also secures the brake caliper) and tighten to the correct torque.
- 29 Tighten the brake hose locknut to the fixing bracket.
- 30 Fit the road wheel and lower the car.

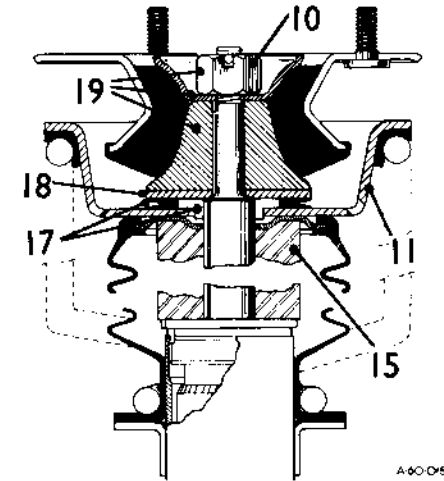

**FRONT HUB**

Remove and refit

**60.25.01****Removing**

- 1 Jack up the car and support the body on stands.
- 2 Remove the caliper. 70.55.02.
- 3 Prise off the hub cap and wipe grease from the end of the stub axle.
- 4 Remove the split pin, nut retaining cap, nut and washer from the stub axle.
- 5 Withdraw the hub complete with disc, bearings and oil seal.

**Refitting**

- 6 Partially pack the hub with fresh grease.
- 7 Locate the oil seal in the hub and enter the hub and bearings on the stub axle.
- 8 Fit the washer and slotted nut to the stub axle.
- 9 Tighten the slotted nut to a torque of 5 lbf ft (0.691 kgf m) back off one flat, fit the nut retaining cap and secure with a split pin.
- 10 Position the brake pipe to the fixing bracket on the damper tube.
- 11 Fit the caliper. 70.55.02.
- 12 Fit the road wheel and lower the car.

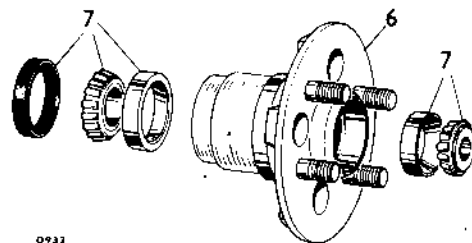
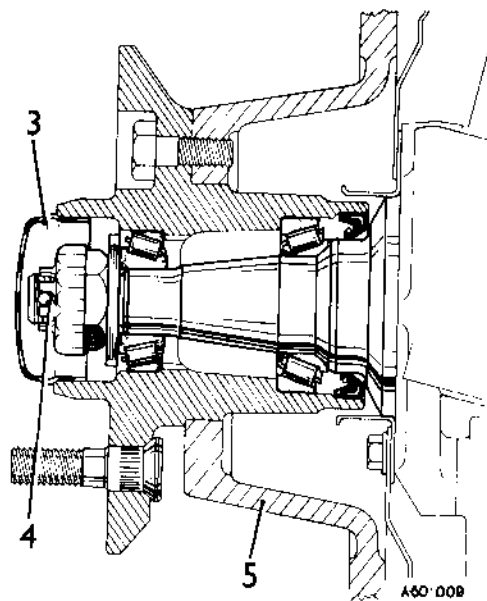

0933

**FRONT HUB BEARING  
END-FLOAT**

Check and adjust

**60.25.13**

- 1 Remove the road wheel.
- 2 Check the hub for end-float.
- 3 If adjustment is required remove hub cap and split pin.
- 4 Tighten the slotted nut as required to eliminate end-float. A torque of 5 lbf ft (0.691 kgf m) must not be exceeded or damage may be caused to the bearings and bearing tracks. Back off one flat and fit the nut retaining cap.
- 5 Insert and lock the split pin.
- 6 Clean the hub cap and refit.
- 7 Fit the road wheels.

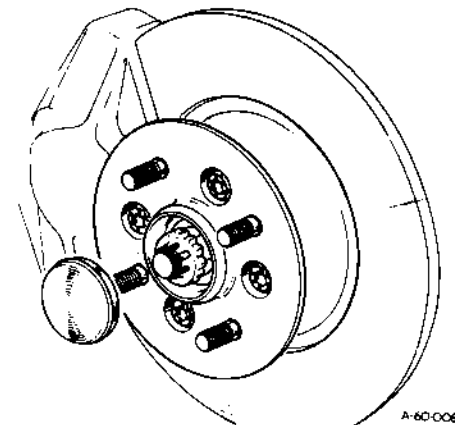

A-60-008

**FRONT HUB BEARINGS**

Remove and refit

**60.25.14****Removing**

- 1 Remove the front hub. 60.25.01.
- 2 Remove the outer bearing, inner oil seal and inner bearing.
- 3 Thoroughly clean the hub.
- 4 Drift the outer and inner bearing tracks from the hub.

**Refitting**

- 5 Clean the bearing track recesses in the hub.
- 6 Install the new tracks in the hub, ensuring that they abut against the machined lip.
- 7 Fit a new oil seal. 60.25.15.
- 8 Fit the hub assembly to the car. 60.25.01.

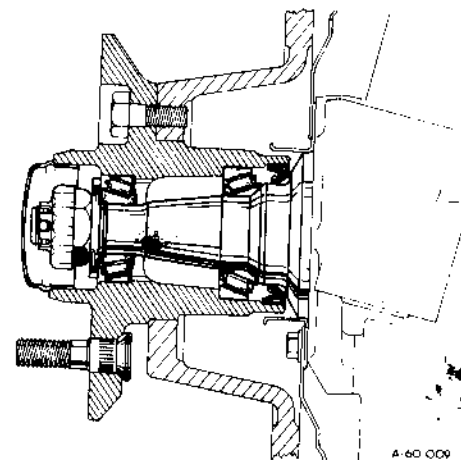

A-60-009

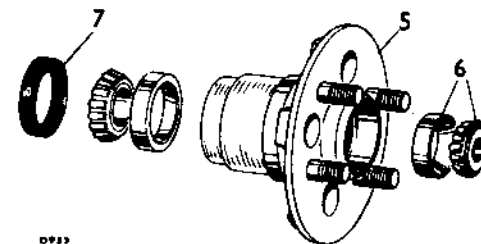

0933



## FRONT HUB OIL SEAL

Remove and refit

60.25.15

### Removing

- 1 Remove the front hub. 60.25.01.
- 2 Extract the oil seal from the hub.

### Refitting

- 3 Insert the new oil seal (lip towards bearing) into hub and press or drift evenly into position.
- 4 Lubricate the seal lip.
- 5 Ensure that the seal deflector ring, incorporated in the disc shield is not damaged and does not foul the hub.
- 6 Fit the hub to the car. 60.25.01.

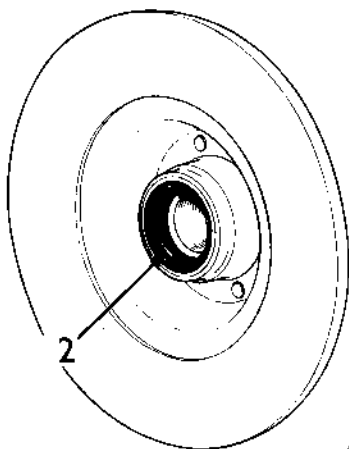

## STUB AXLE ASSEMBLY

Remove and refit

60.25.22

### Removing

- 1 Remove the road spring. 60.20.01.
- 2 Remove the front damper cartridge. 60.30.02.
- 3 Remove the front hub. 60.25.01, instructions 7 to 9.
- 4 Remove the three bolts securing the disc shield.

### Refitting

- 5 Secure the disc shield with the three bolts and spring washers.
- 6 Refit the front hub. 60.25.01, instructions 10 to 15.
- 7 Fit the front damper cartridge. 60.30.02.
- 8 Fit the road spring to the car. 60.20.01.

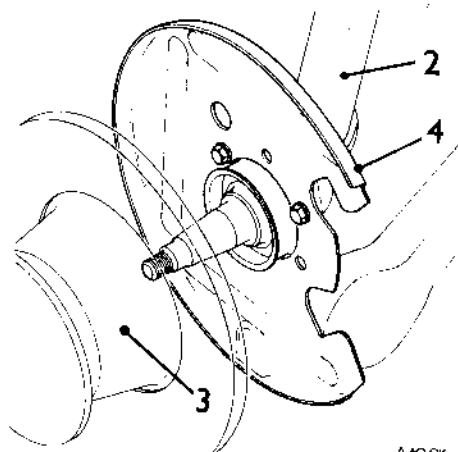

## WHEEL STUD

Remove and refit

60.25.29

### Removing

- 1 Remove the front hub. 60.25.01.
- 2 Remove the four bolts retaining the hub to the brake disc and remove the hub from the disc.
- 3 Extract the stud from the hub.

### Refitting

- 4 Ensure that the mating countersunk faces of the stud and the flange are clean.
- 5 Enter the stud from the rear of the hub flange, align the splines and press into position.
- 6 Fit the front hub to the disc and evenly tighten the four bolts 25-32 lbf ft (3.46-4.42 kgf m).
- 7 Fit the front hub to the stub axle. 60.25.01.

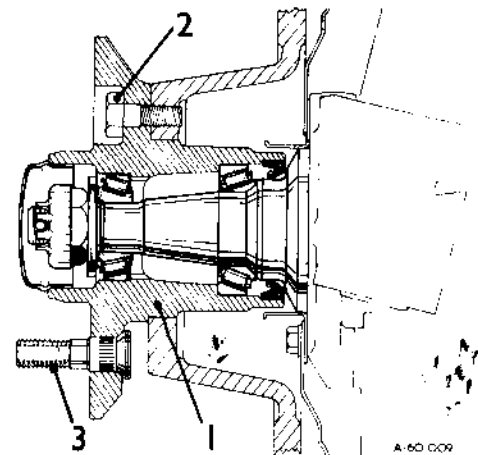

## FRONT DAMPER

Remove and refit

60.30.02

Service tool: RTR 359

### Removing

- 1 Remove the front road spring. 60.20.01.
- 2 Using the special tool undo the closure nut.
- 3 Remove the damper cartridge.

### Refitting

- 4 Fit the damper cartridge.
- 5 Fit the closure nut, and tighten to the correct torque.
- 6 Fit the road spring. 60.20.01.

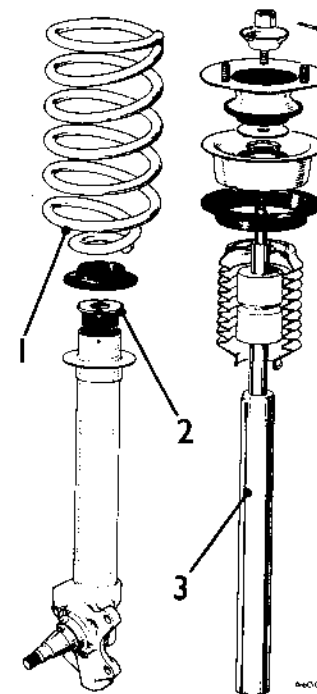

## FRONT STRUT UPPER SWIVEL ASSEMBLY

Remove and refit

60.30.04

As operation 60.20.01.

**BOTTOM LINK**

Remove and refit

60.40.02

**Removing**

- 1 Jack up the car and support the body on stands.
- 2 Remove the road wheel.
- 3 Remove the spring pin, nyloc nut, flat washer and outer rubber bush from the end of the anti-roll bar.
- 4 Remove the two bolts securing the steering arm to the stub axle assembly and push clear.
- 5 Remove the split pin, slotted nut and plain washer and release the ball joint from the stub axle assembly.
- 6 Remove the bolt and nyloc nut securing the bottom link to the sub frame. Withdraw the bottom link.

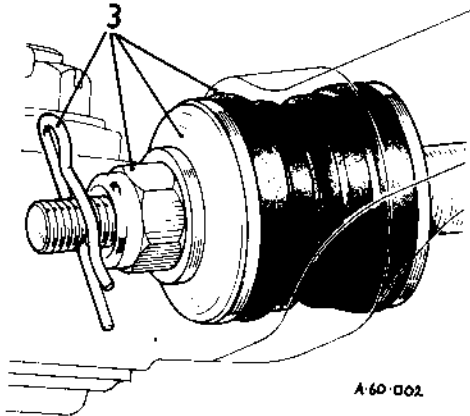
**Refitting**

- 7 Locate the anti-roll bar into the mounting hole in the bottom link.
- 8 Position the bottom link and secure to the sub frame with the bolt and nyloc nut. DO NOT tighten fully until the car is resting on its wheels.
- 9 Fit the ball joint into the stub axle assembly and secure with the flat washer, slotted nut and split pin.
- 10 Place the jack under the bottom link and carefully raise the link to locate the outer rubber bush, dished washer, flat washer and nyloc nut onto the end of the anti-roll bar.
- 11 Tighten the nyloc nut to the stop and fit the spring pin.
- 12 Lower the jack.
- 13 Fit the steering arm and tighten the two bolts.
- 14 Fit the road wheel and lower the car.

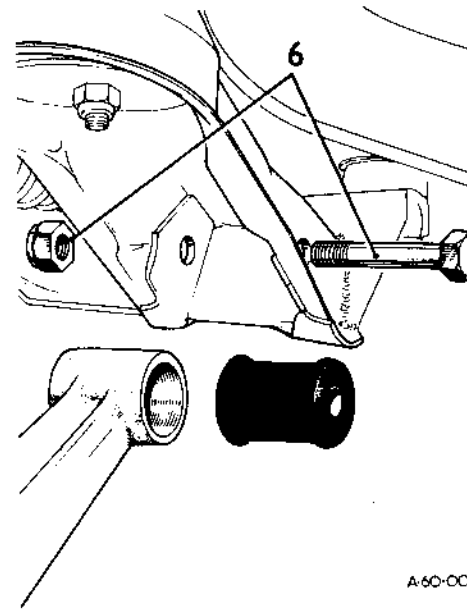
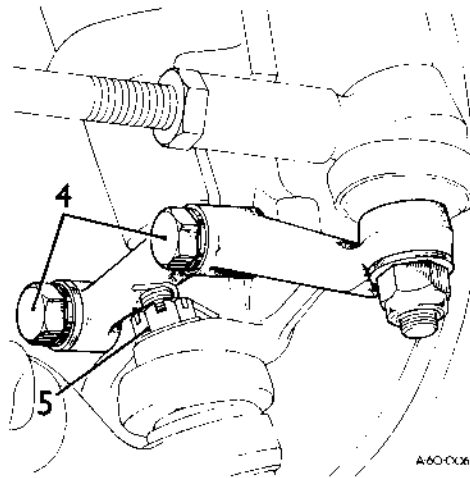
**BOTTOM LINK**

Overhaul

60.40.06

- 1 Remove the bottom link. 60.40.02.
- 2 Remove the plastic gaiter and rubber ring from the ball joint.
- 3 Remove the circlip retaining the ball joint housing to the bottom link.
- 4 Press or drive out the ball joint and housing.
- 5 Enter the new ball joint and housing from the underside of the bottom link ensuring that the housing is squarely located.
- 6 Press the housing into the bottom link taking care not to damage the bottom of the housing. (A short length of suitable diameter tube is recommended.)
- 7 Fit the circlip, new plastic gaiter and gaiter retaining ring.
- 8 Press out the rubber bush and sleeve from the fulcrum end of the bottom link.
- 9 Press the new bush and sleeve into position.

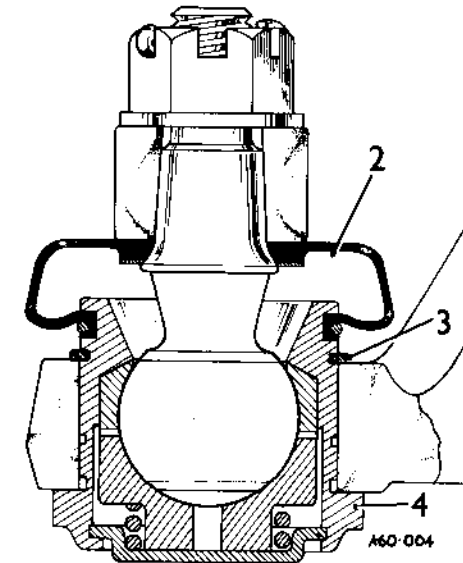

## ROAD SPRING

Remove and refit 64.20.01  
Insulating rings 64.20.17

### Removing

- 1 Jack up the car and support the body on stands.
- 2 Remove the road wheel.
- 3 Transfer the jack to support the suspension arm and partially compress the road spring, taking care not to relieve the weight on the stands.
- 4 Remove the two nuts and bolts securing one side of the anti-roll bar to the suspension arm.
- 5 Remove the nut and bolt securing the rear end of the suspension arm to the axle bracket.
- 6 Carefully lower the jack.
- 7 Remove the spring and its upper and lower insulating rubbers.

### Refitting

- 8 Ensure that the spring insulating rubbers are correctly positioned and fit the spring.
- 9 Position the jack under the suspension arm.
- 10 Carefully raise the jack and engage the rear end of the suspension arm in the axle bracket.
- 11 Fit the bolt and nut.
- 12 Connect the anti-roll bar to the suspension arm.
- 13 Fit the road wheel.
- 14 Remove the stands and lower the car.
- 15 Tighten the nut and bolt securing the rear end of the suspension arm to the axle bracket.

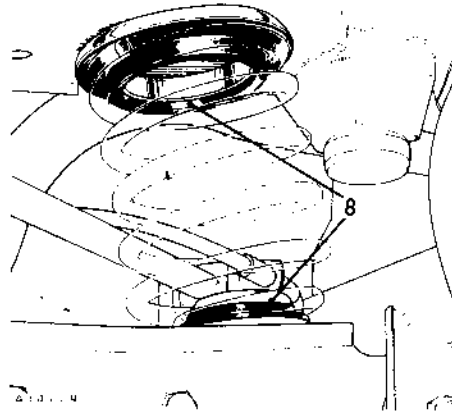
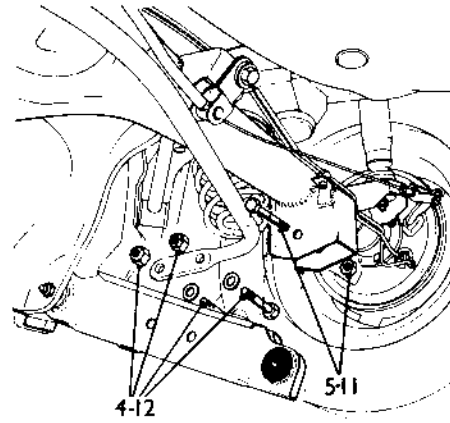

## REAR DAMPER LEFT HAND

Remove and refit 64.30.02

### Removing

- 1 Jack up the car and support the body on stands.
- 2 Remove the rear wheel.
- 3 Remove the three screws securing the damper access plate to the body in the boot. Remove the plate.
- 4 Remove the locknut, nut, plain washer and rubber bush securing the upper end of the damper to the body.
- 5 Remove the locknut, nut, plain washer and rubber bush securing the lower end of the damper to the axle bracket.
- 6 Withdraw the damper.
- 7 Remove the rubber and plain washer from each end of the damper.

### Refitting

- 8 Fit the plain washer and rubber bush to the upper end of the damper.
- 9 Position the damper on the car. Fit the rubber, plain washer, nut and locknut securing the upper end of the damper to the body.
- 10 Apply a plasti-seal, to the damper cover plate. Fit the plate and secure with the three screws.
- 11 Fit the plain washer and rubber to the lower end of the dampers. Position the damper in the axle bracket and secure with the rubber, bush, plain washer, nut and locknut.
- 12 Refit the road wheel.
- 13 Remove the stands and lower the car.

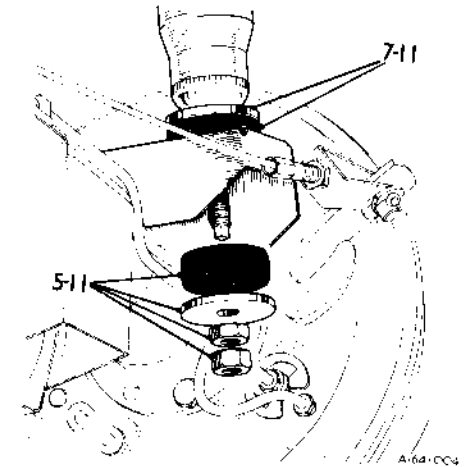
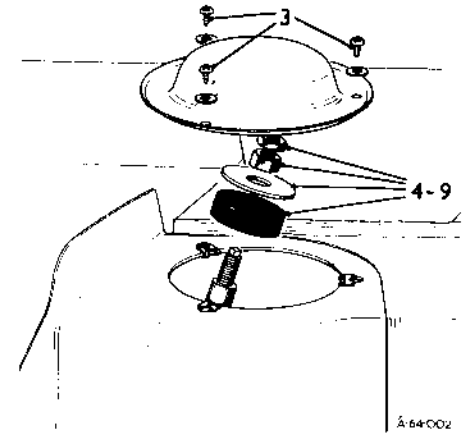

**REAR DAMPER RIGHT HAND**Remove and refit **64.30.03****Removing**

- 1 Jack up the car and support the body on stands.
- 2 Remove the rear road wheel.
- 3 Remove the fuel filler cap and filler assembly. 19.55.08.
- 4 Remove the locknut, nut, plain washer and rubber bush securing the upper end of the damper to the body.
- 5 Remove the locknut, nut, plain washer and rubber bush securing the lower end of the damper to the axle bracket.
- 6 Withdraw the damper.
- 7 Remove the rubber bush and plain washer from each end of the damper.

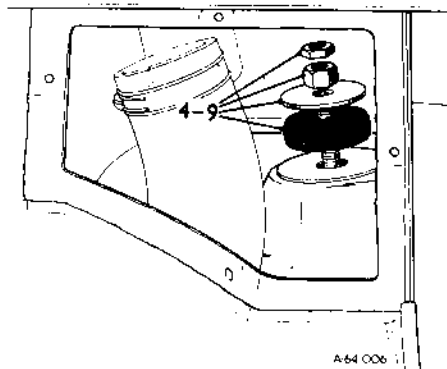
**Refitting**

- 8 Fit the plain washer and rubber bush to the upper end of the damper.
- 9 Position the damper on the car. Fit the rubber bush, plain washer, nut and locknut, securing the upper end of the damper to the body.
- 10 Fit the fuel filler cap and filler assembly. 19.55.08.
- 11 Fit the plain washer and rubber bush to the lower end of the damper. Position the damper in the axle bracket and secure with the rubber bush, plain washer, nut and locknut.
- 12 Refit the road wheel.
- 13 Remove the stands and lower the car.

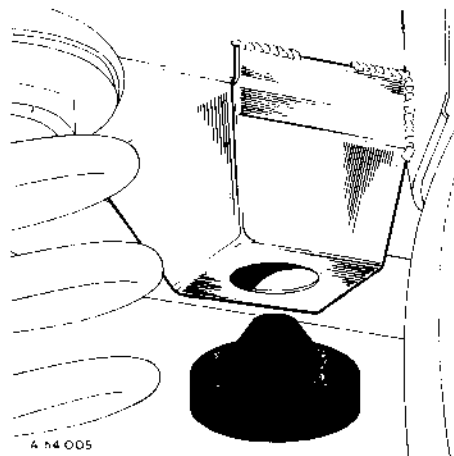
**BUMP STOP**Remove and refit **64.30.15****Removing**

- 1 Remove the bump stop from its mounting.

**Refitting**

- 2 Press new bump stop into position.

**SUSPENSION ARM**Remove and refit **64.35.02****Removing**

- 1 Jack up the car and support the body on stands.
- 2 Remove the road wheel.
- 3 Transfer the jack to support the suspension arm and partially compress the road spring, taking care not to relieve the weight on the stands.
- 4 Remove two nuts and bolts securing the anti-roll bar to the suspension arm.
- 5 Remove the nut and bolt securing the rear end of the suspension arm to the axle bracket.
- 6 Carefully lower the jack.
- 7 Remove the spring.
- 8 Remove the nut and bolt securing the forward end of the suspension arm to the body bracket.
- 9 Detach the suspension arm from the bracket.

**Refitting**

- 10 Engaging the forward end of the suspension arm in the body bracket, fit the bolt and nut. Do not tighten at this stage.
- 11 Place the jack under the suspension arm.
- 12 Ensure that the spring insulating rubbers are correctly positioned and fit the spring.
- 13 Raise the jack and engaging the rear end of the suspension arm in the axle bracket, fit the bolt and nut. Do not tighten at this stage.
- 14 Connect the anti-roll bar to the suspension arm.
- 15 Fit the road wheel.
- 16 Remove the stands and lower the car.
- 17 Tighten the front and rear suspension arm, nuts and bolts.

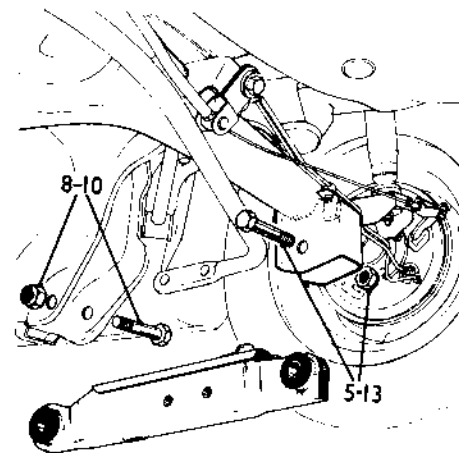

A 64-000

## SUSPENSION ARM BUSHES

Remove and refit 64.35.05

### Removing

- 1 Remove the suspension arm. 64.35.02.
- 2 Press out the old bushes.

### Refitting

- 3 Press in the new bushes ensuring that they are centralized in the suspension arm. Note that the front bush must be installed in the position illustrated.
- 4 Fit the suspension arm. 64.35.02.

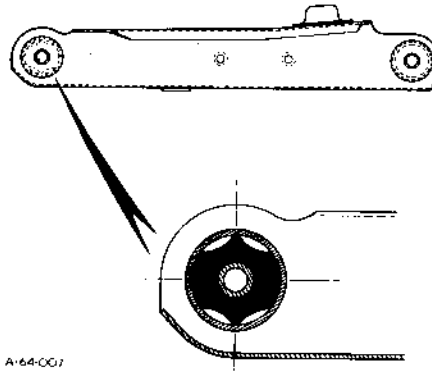

## ANTI-ROLL BAR

Remove and refit 64.35.08

### Removing

- 1 Raise the car and support it safely.
- 2 Remove the four bolts and nuts (two either side) securing the anti-roll bar to the rear suspension arms.
- 3 Withdraw the anti-roll bar and shim(s), if fitted.

### Refitting

- 4 Locate the anti-roll bar (and shim(s), if removed) in position on the rear suspension arms.
- 5 Align the mounting holes and fit and tighten the four securing bolts and nuts.
- 6 Lower the car.

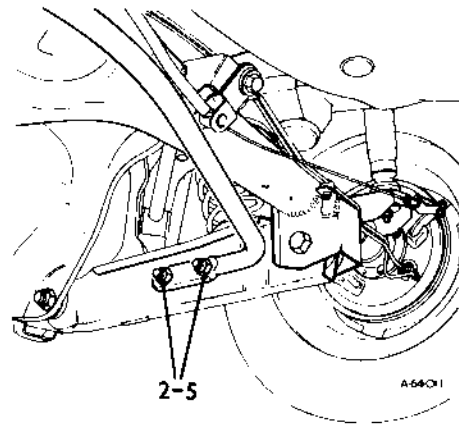

## RADIUS ROD

Remove and refit 64.35.28

### Removing

- 1 Jack up the car and support the body on stands.
- 2 Remove the nut and bolt securing the rear end of the radius rod to the rear axle bracket.
- 3 Remove the nut and bolt securing the forward end of the radius rod to the body bracket.
- 4 Withdraw the radius rod.

### Refitting

- 5 Refit the radius rod.
- 6 Engage the forward end of the radius rod in the body bracket and fit the bolt and nut.
- 7 Engage the rear end of the radius rod in the axle tube bracket. Fit the bolt and nut.
- 8 Tighten both nuts.
- 9 Remove the stands and lower the car.

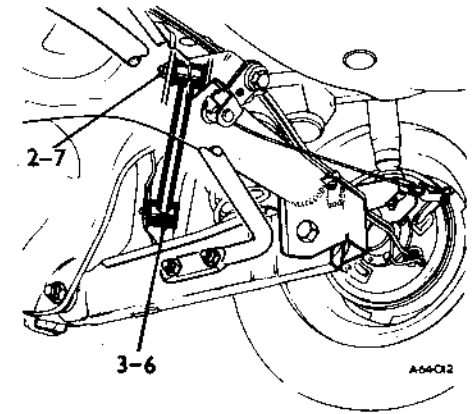

## RADIUS ROD BUSHES

Remove and refit 64.35.29

### Removing

- 1 Remove the radius rod from the car. 64.35.28.
- 2 Press out the bush from the radius rod.

### Refitting

- 3 Fit a new bush to the radius rod.
- 4 Install the radius rod in the car. 64.35.28.

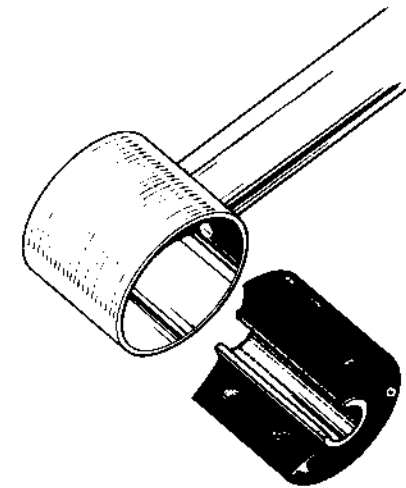

### PRESSURE REDUCING VALVE

Description 70.00.00

The pressure reducing valve is installed in the brake circuit between the master cylinder and the front and rear brakes. Its function is to limit the pressure applied to the rear brakes relative to the pressure applied to the front brakes, thus minimizing the possibility of rear wheel locking. In the event of a failure in the front brake circuit the cut-off pressure is increased and the pressure reduction ratio changes.

#### Operation

Fluid from the primary chamber of the master cylinder is fed into the pressure reducing valve at port A and out to the front brakes via ports C and D. The master cylinder secondary chamber feeds into port B, through the internal passages in the valve plunger, past the metering valve and out to the rear brakes via port E. The large spring S is pre-loaded to bias the valve plunger to the left. Hydraulic pressure therefore acts on the annular area (a1 - a2) forcing the plunger to the left while the force acting on area a1 and annular area (a4 - a3) tends to move the plunger to the right where it is opposed by spring S. When the net force acting to the right overcomes the pre-load provided by spring S the plunger assembly shifts to the right thereby closing the metering valve F. Pressure at

the rear outlet port E therefore falls relative to the input pressure. As pressure is increased at ports A and B the plunger is forced to the left, opening the metering valve F and permitting a small quantity of fluid to be fed to the rear brakes. The resultant increase in pressure acting on area a1 causes the plunger to again shift to the right closing the metering valve. This procedure continues until there is no further increase in pressure from the master cylinder.

The pressure at outlet E is reduced after cut-off in proportion to the areas a2 and the difference between the two annular areas (a1 - a2) and (a4 - a3). The cut-off pressure is equal to the pre-load in the spring S divided by the combined areas a2 and (a4 - a3). Should the front brake circuit fail there will be no pressure acting on annular area (a4 - a3) so that the net force tending to move the plunger to the right will be equivalent to the product of the input pressure and area a2. Thus, as the value of the pre-load spring S is unchanged, the cut-off pressure will increase considerably (approximately threefold). As the annular area (a4 - a3) is now redundant, the reduction ratio after cut-off changes to a value which is proportional to the areas a1 and (a1 - a2). Should the rear brake circuit fail the pressure reducing valve is completely inoperative and pressure is fed to the front brakes in the normal manner.

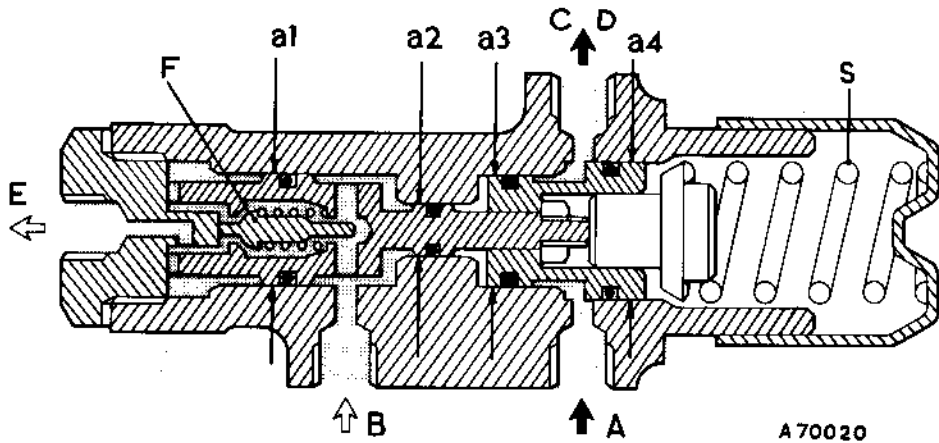

A 70020

### REAR BRAKE-DRUM

Remove and refit 70.10.03

#### Removing

- 1 Jack up the car and support the body on stands.
- 2 Remove the road wheel.
- 3 Release the hand brake.
- 4 Remove the countersunk screw(s) securing the brake-drum to the hub and withdraw the brake-drum.

#### Refitting

- 5 Align the countersunk hole(s) in the drum with the tapped hole(s) in the hub.
- 6 Engage the wheel studs in the drum.
- 7 Slide the drum into position. If the brake-shoes were disturbed, they may require to be centralized on the backplate to allow drum entry.
- 8 Fit and tighten the countersunk screw(s).
- 9 Fit the road wheel and lower the jack.
- 10 Apply the foot brake several times to adjust the rear brakes.

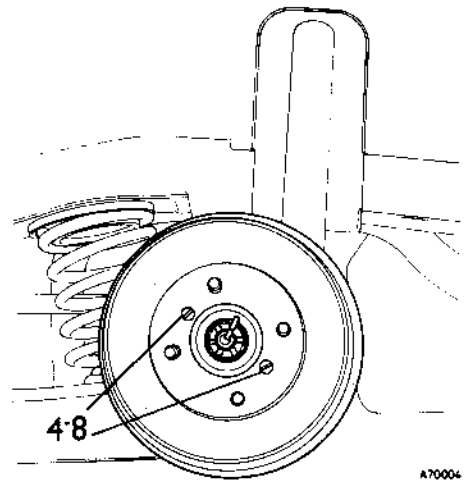

A70004

### BRAKE DISC

Remove and refit 70.10.10

#### Removing

- 1 Remove the front hub, see 60.25.01.
- 2 Remove the four bolts securing the disc to the hub.
- 3 Withdraw the disc.

#### Refitting

- 4 Offer up the disc to the hub.
- 5 Fit and evenly tighten to 25 to 32 lbf ft (3.5 to 4.4 kgf m) the four bolts securing the disc to the hub.
- 6 Fit the front hub to the stub axle and adjust, see 60.25.01.

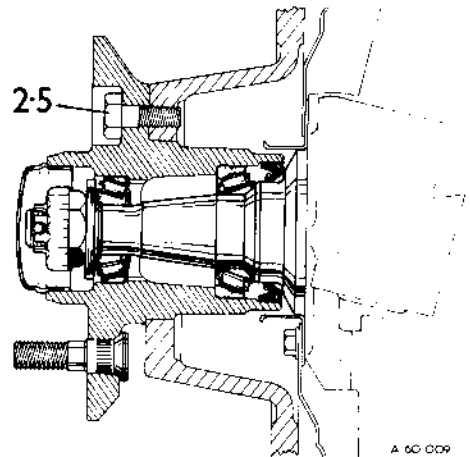

A 60 009

## DISC SHIELD

Remove and refit 70.10.18

### Removing

- 1 Remove the front hub, see 60.25.01.
- 2 Remove the three bolts and spring washers securing the disc shield to the vertical link assembly.
- 3 Remove the disc shield.

### Refitting

- 4 Position the disc shield over the stub axle and secure to the vertical link with the three bolts and spring washers.
- 5 Fit the front hub to the stub axle and adjust, see 60.25.01.

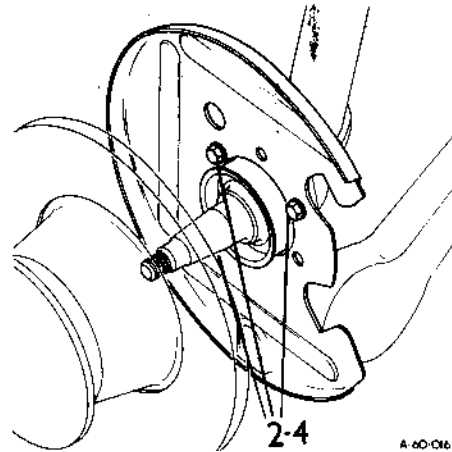

## BRAKE HOSE – FRONT

Remove and refit – Left-hand 70.15.02  
– Right-hand 70.15.03

### Removing

- 1 Disconnect the brake pipe and union from the inboard end of the flexible hose.
- 2 Disconnect the brake pipe and union from the outboard end of the flexible hose.
- 3 Using two spanners, remove the locknuts and washers securing the hose to the support brackets, one on the wheel arch the other on the damper tube, and remove the hose.

### Refitting

- 4 Reverse instructions 1 to 3. Ensure that the hose is neither kinked nor twisted when installed.
- 5 Bleed the brakes.

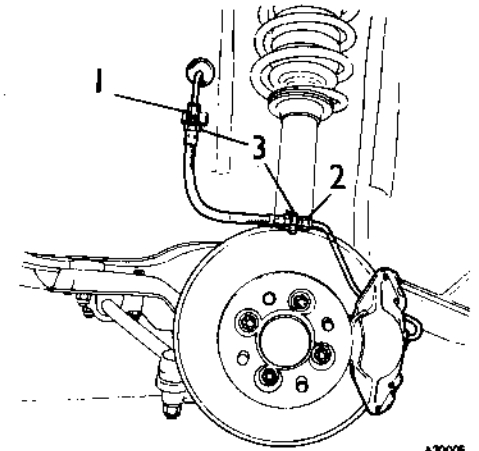

## REAR BRAKE BACKPLATE

Remove and refit 70.10.26

### Removing

- 1 Jack up the car and support the body on stands.
- 2 Remove the rear road wheel and release the hand brake.
- 3 Remove the rear hub, see 51.10.18.
- 4 Remove the clevis pin securing the hand brake cable fork to the back plate lever.
- 5 Disconnect the fluid feed pipe union at the wheel cylinder (left-hand side only);  
or  
Disconnect the fluid feed and transfer pipe unions at the wheel cylinder (right-hand side only).
- 6 Remove four nuts, spring washers, and bolts securing the backplate to the axle casing flange.
- 7 Withdraw the deflector plate and the backplate.

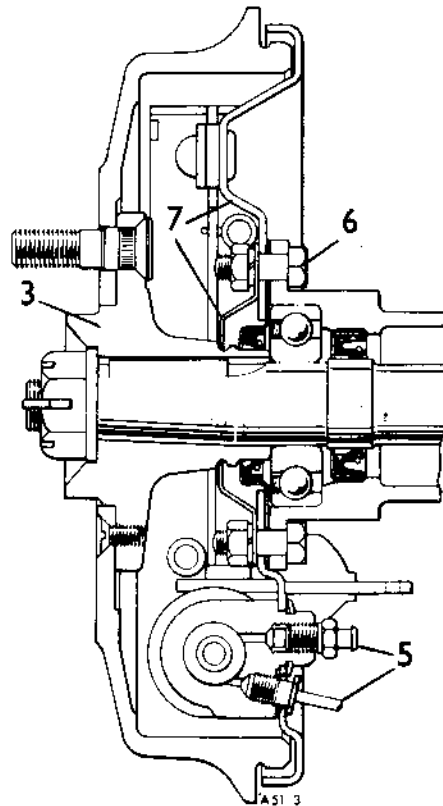

### Refitting

- 7 Reverse instructions 1 to 7.
- 8 Bleed the brakes.

## BRAKE HOSE – REAR

Remove and refit 70.15.17

### Removing

- 1 Disconnect the brake pipe and union at the front end of the brake hose.
- 2 Disconnect the brake pipe and union at the rear end of the brake hose.
- 3 Using two spanners, remove the locknuts and washers securing the hose to the brackets, one on the body, the other on the axle tube. Remove the brake hose.

### Refitting

- 4 Reverse instructions 1 to 3. Ensure that the hose is neither kinked nor twisted when installed.
- 5 Bleed the brakes.

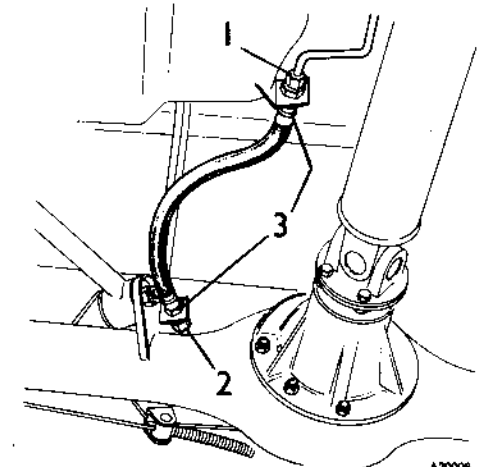

### HYDRAULIC PIPES

Remove and refit 70.20.00

To aid identification of individual pipes, operation numbers are included in the illustration showing the general arrangement of the brake system.

- Pipe – master cylinder to pressure reducing valve – front brakes 70.20.44
- Pipe – master cylinder to pressure reducing valve – rear brakes 70.20.45
- Pipe – pressure reducing valve to L.H. front hose 70.20.02
- Pipe – pressure reducing valve to R.H. front hose 70.20.03
- Pipe – L.H. front hose to caliper 70.20.04
- Pipe – R.H. front hose to caliper 70.20.05
- Pipe – Pressure reducing valve to rear hose 70.20.13
- Pipe – R.H. rear wheel cylinder to L.H. rear wheel cylinder 70.20.17
- Pipe – rear hose to R.H. rear wheel cylinder 70.20.18

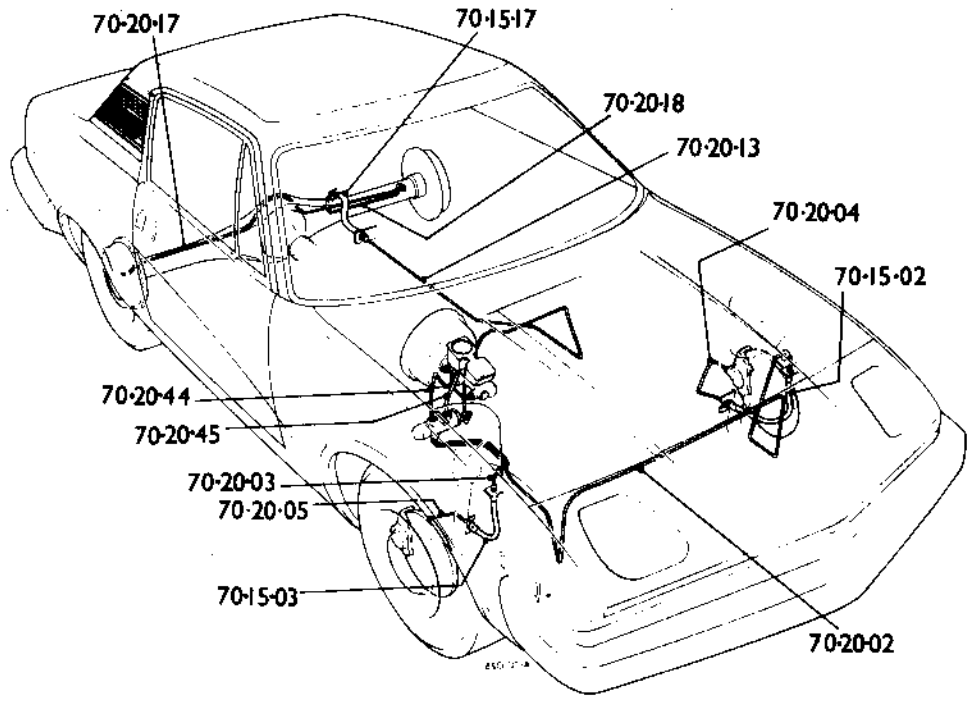



## BRAKES

### Bleed

70.25.02

Do not allow the fuel level in the reservoir to fall below half capacity. When topping-up during the bleeding process, DO NOT USE aerated fluid exhausted from the system. DO NOT bleed the system with the servo in operation (engine running).

- 1 Disconnect the wires to the pressure failure switch and remove the pressure failure switch from the underside of the master cylinder.
- 2 Release the hand brake.
- 3 Attach the bleed tube to the bleed nipple of the front caliper farthest from the master cylinder, allowing the free end of the bleed tube to hang submerged in brake fluid in a transparent container.
- 4 Open the bleed nipple (90 to 180 degrees).
- 5 Fully depress the brake pedal and follow with three rapid successive strokes. Allow the pedal to return. Repeat this procedure until fluid free from air bubbles issues from the wheel cylinder.
- 6 Depress the brake pedal, close the nipple and release the pedal.
- 7 Remove the bleed tube.
- 8 Attach the bleed tube to the opposite front caliper and repeat instructions 4 to 7.
- 9 Attach the bleed tube to the single nipple on the rear backplate (R.H. Stg. - left-hand backplate; L.H. Stg. - right-hand backplate) and repeat instructions 4 to 7.
- 10 Fit the pressure failure switch to the master cylinder and connect the wires. The P.D.W.A. shuttle fitted to this vehicle is self-centring.

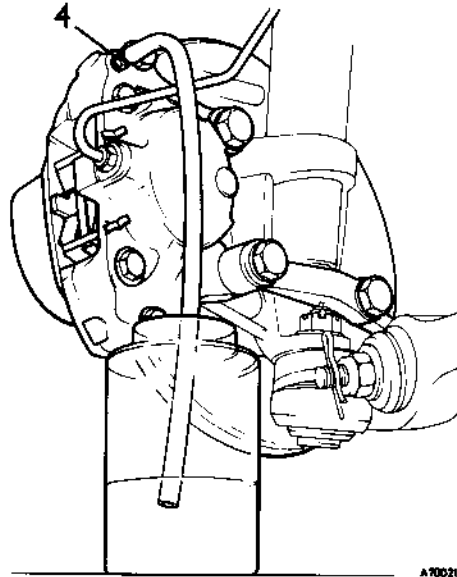

## BRAKES

### Adjust

70.25.03

Self-adjusting brakes are fitted to the front and rear. Front adjustment is hydraulically self-compensating to provide for brake pad wear. In the rear brakes a self-adjusting mechanism incorporated in the brake-shoe hand brake linkage maintains a fixed brake liner/drum running clearance; self-adjustment occurs on the application of the footbrake.

## PRESSURE REDUCING VALVE

### Remove and refit

70.25.21

#### Removing

- 1 Slacken the brake pipe unions at the master cylinder.
- 2 Remove the two inlet pipes from the top of the pressure reducing valve.
- 3 Remove the rear brake outlet pipe from the end plug of the pressure reducing valve.
- 4 Remove the two front brake outlet pipes from the underside of the pressure reducing valve. To facilitate removal of the L.H. front brake pipe, first remove the R.H. front brake pipe from the pressure reducing valve and detach the pipe from the clip on the inner wheel arch.
- 5 Remove the nut, plain washer, spring washer and bolt, and remove the pressure reducing valve with the bracket from the suspension turret.

#### Refitting

- 6 Align the lugs on the bracket with the holes in the suspension turret.
- 7 Fit the pressure reducing valve and secure to the suspension turret with the bolt, plain washer, spring washer and nut.
- 8 Fit the brake pipes, tighten the pressure reducing valve unions, and attach the R.H. front brake pipe to the clip on the inner wheel arch.
- 9 Tighten the brake pipe unions at the master cylinder.
- 10 Bleed the brakes.

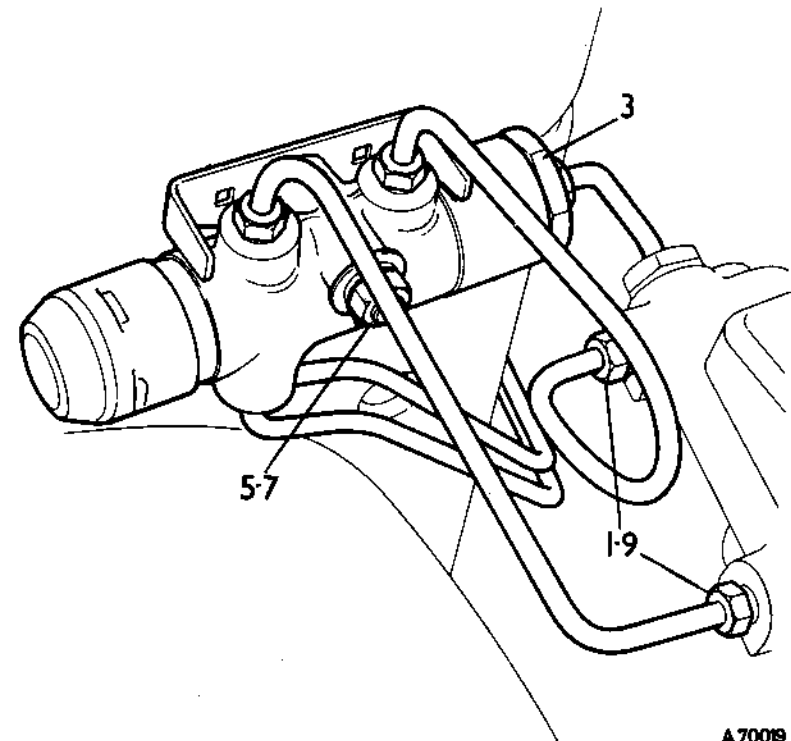

**MASTER CYLINDER – TANDEM**

Remove and refit 70.30.08

**Removing**

- 1 Noting their positions, disconnect the brake pipes at the master cylinder. Plug the master cylinder ports to prevent fluid discharge from the reservoir. Seal the brake pipes to prevent ingress of foreign matter.
- 2 Disconnect the wires to the pressure failure switch.
- 3 Remove the two nuts and spring washers securing the master cylinder to the servo and withdraw the master cylinder.

**Refitting**

- 4 Reverse instructions 1 to 3.
- 5 Bleed the brakes.

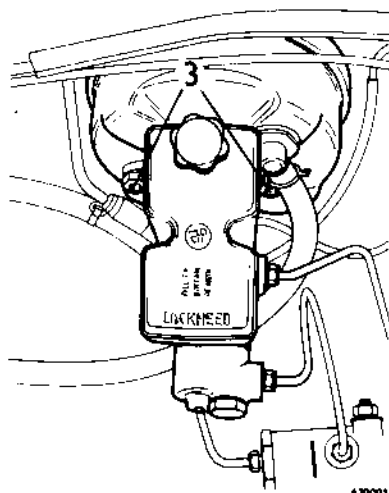

A70003

- 10 Unscrew the pressure failure switch from the cylinder body.
- 11 Remove the end plug and copper washer, withdraw the distance piece, and the piston and spring sub assembly.
- 12 Carefully remove the two rubber seals.

**Inspection**

- 13 Clean all the components thoroughly in a recommended brake fluid and dry using a lint-free cloth.
- 14 Carefully inspect the metal components for faults and wear. A replacement assembly must be fitted if the cylinder bores show the slightest signs of corrosion, ridging or scoring.

- 15 Ensure that all the ports and drillings in the cylinder body, piston heads and the vent hole in the filler cap are clear of any obstructions.

**Reassembly**

**CAUTION:** Scrupulous cleanliness is essential. Immerse all components in a recommended brake fluid and assemble when wet.

- 16 Fit new seals and washers to the primary and secondary pistons, using only the fingers.
- 17 Fit the secondary return spring, spring retainer and piston into the cylinder bore, taking care not to bend back the lip of the seal.
- 18 With a soft metal rod, depress the secondary piston. When the head of the piston passes the secondary fluid feed port, fit the piston stop pin.
- 19 Fit the primary return spring, spring retainer and piston into the cylinder bore, ensuring that the lip of the seal is not bent back.
- 20 Fit the circlip at the mouth of the cylinder bore and check that it is correctly seated in the groove.
- 21 Fit the two rubber seals into the cylinder body recesses.
- 22 Ensure that the reservoir is clean and fit to the master cylinder body with the two screws. Tighten to a torque of 5 lbf ft (0.69 kgf m). DO NOT overtighten.
- 23 Fit two new 'O' rings into the grooves on the P.D.W.A. piston and spring sub-assembly.
- 24 Insert the piston and spring sub-assembly into its respective bore, taking care not to damage the 'O' rings.
- 25 Fit the metal distance piece.
- 26 Fit a new copper washer to the end plug and screw into the bore. Tighten to a torque of 33 lbf ft (4.56 kgf m).
- 27 Fit the master cylinder to the car, see 70.30.08.
- 28 Bleed the brakes.

**MASTER CYLINDER – TANDEM**

Overhaul 70.30.09

**Dismantling**

- 1 Remove the tandem master cylinder from the car, see 70.30.08.
- 2 Drain the fluid from the reservoir.
- 3 Remove the two screws securing the fluid reservoir to the master cylinder and remove the reservoir.
- 4 Noting their original positions, remove the two rubber seals from the cylinder body recesses.
- 5 Remove the metal cap and rubber boot from the end of the master cylinder.
- 6 Remove the circlip, withdraw the primary piston and return spring.
- 7 Insert a soft metal rod into the cylinder and depress the secondary piston. This will release the stop pin which is seated adjacent to the secondary piston fluid feed port.
- 8 Remove the pin and withdraw the secondary piston, the spring retainer and the return spring.
- 9 Carefully note the sizes and positions of the rubber seals, the piston washers and the spring retainers. Remove the seals using only the fingers.

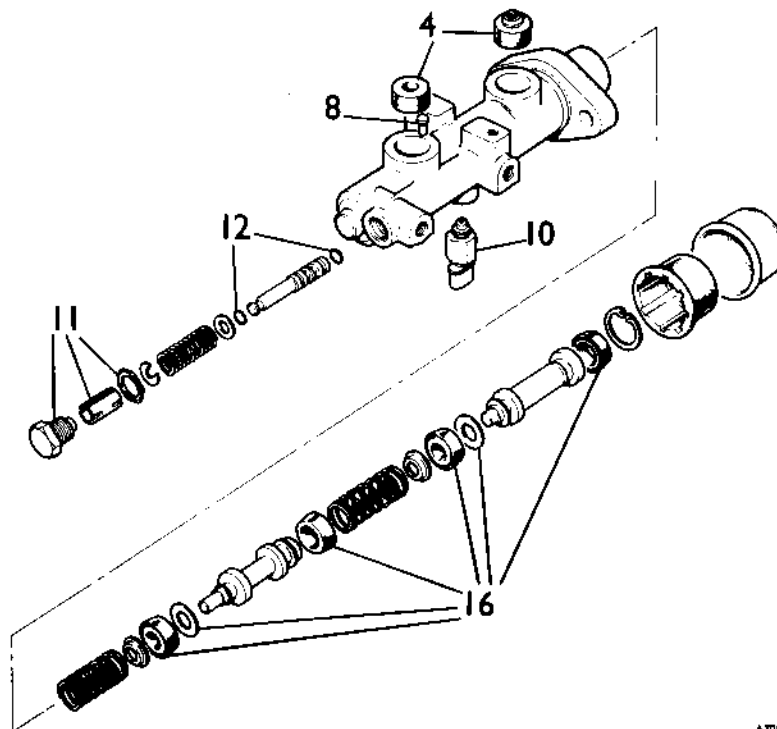

A70001

## PEDAL BOX

### Remove and refit

70.35.03

#### Removing

- 1 Disconnect the two spade terminals from the brake stop light switch.
- 2 Remove the speedo cable from its retaining clip.
- 3 Remove the clevis pin securing the brake pedal to the brake master cylinder rod.
- 4 Remove the clevis pin securing the clutch pedal to the clutch master cylinder rod.
- 5 Remove the four nuts and spring washers securing the servo to the pedal box.
- 6 Remove the two nuts, bolts and spring washers securing the clutch master cylinder to the pedal box.
- 7 Remove the cleat securing the harness to the stabilizer bar.
- 8 Remove the nut and bolt securing the stabilizer bar to the fascia rail.
- 9 Remove the three bolts and spring washers securing the top of the pedal box to the body.
- 10 Withdraw the pedal box assembly.

#### Refitting

- 11 Reverse instructions 1 to 10.

## PEDAL BOX

### Overhaul

70.35.04

- 1 Remove the pedal box from the car, see 70.35.03.
- 2 Remove the brake stop light switch.
- 3 Remove the circlip from one end of the pedal pivot rod.
- 4 Push the rod through the bracket.
- 5 Remove the brake and clutch pedals and the two anti-rattle springs.
- 6 Remove and renew the two Teflon coated bushes in each pedal.
- 7 Remove and renew the pedal pad rubbers.
- 8 Locate both the clutch and brake pedals in the pedal box, ensuring that the anti-rattle springs are fitted.
- 9 Push through the pivot rod and secure using the circlip.
- 10 Fit the brake stop light switch.
- 11 Fit the pedal box to the car, see 70.35.03.

## HANDBRAKE LEVER ASSEMBLY

### Remove and refit

70.35.08

#### Removing

- 1 Drive the vehicle onto a ramp. Release the hand brake.
- 2 Raise the ramp.
- 3 Using a screw jack, raise the body to allow access to the underside of the transmission tunnel.
- 4 Pull back the rubber gaiter and release the hand brake cable locknut; note original position.
- 5 Unscrew the hand brake cable from the operating rod.
- 6 Lower the ramp.
- 7 Remove the centre console, see 76.25.01.
- 8 Remove the Lucar connector from the handbrake warning light switch.
- 9 Remove the four bolts and spring washers securing the hand brake lever assembly to the transmission tunnel.
- 10 Withdraw the hand brake lever assembly, the lower plate and the rubber gaiter.

#### Refitting

- 11 Reverse instructions 1 to 10.
- 12 Check the adjustment of the hand brake and rectify as necessary, see 70.35.10.

## HAND BRAKE CABLES

### Adjust

70.35.10

- 1 Jack up the rear of the vehicle and support the axle on stands.
- 2 Release the hand brake.
- 3 Disconnect the hand brake cables from the rear brake backplate levers.
- 4 Applying finger pressure, push the brake operating levers inboard to ensure that the operating levers are in contact with the brake-shoe webs.
- 5 Maintaining the compensator in the vertical position, adjust the cable forks so that the clevis pin can be entered through them and the operating levers without straining the cables. Ensure that the rear wheels do not drag.
- 6 Insert and fix the clevis pins.
- 7 Screw in each fork and adjuster  $3\frac{1}{2}$  complete revolutions and tighten the locknuts.
- 8 Apply alternately the hand and foot brakes several times.
- 9 With 25 lbf effort applied to the hand brake, the travel of the lever should be between four and seven notches.

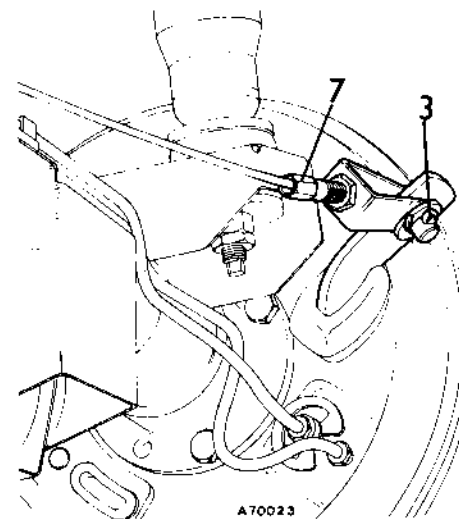
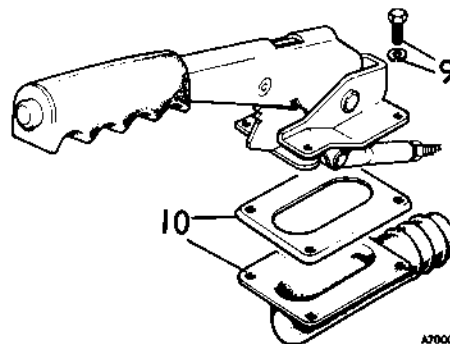
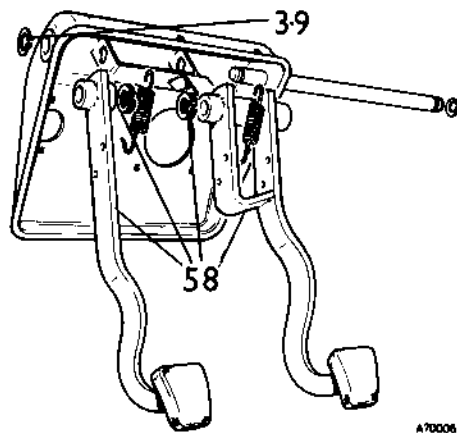
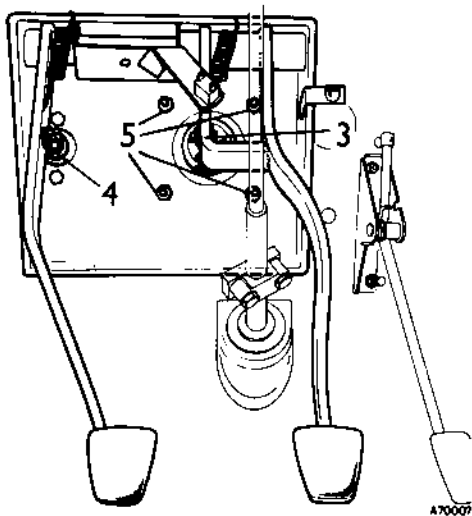

**HAND BRAKE CABLE ASSEMBLY**

Remove and refit 70.35.16

**Removing**

- 1 Drive the vehicle onto a ramp. Release the hand brake.
- 2 Raise the ramp.
- 3 Using a screw jack, raise the body to allow access to the underside of the transmission tunnel.
- 4 Pull back the rubber gaiter and release the hand brake cable locknut.
- 5 Unscrew the hand brake cable from the operating rod.
- 6 Slacken the nut to release the cable from the abutment bracket.

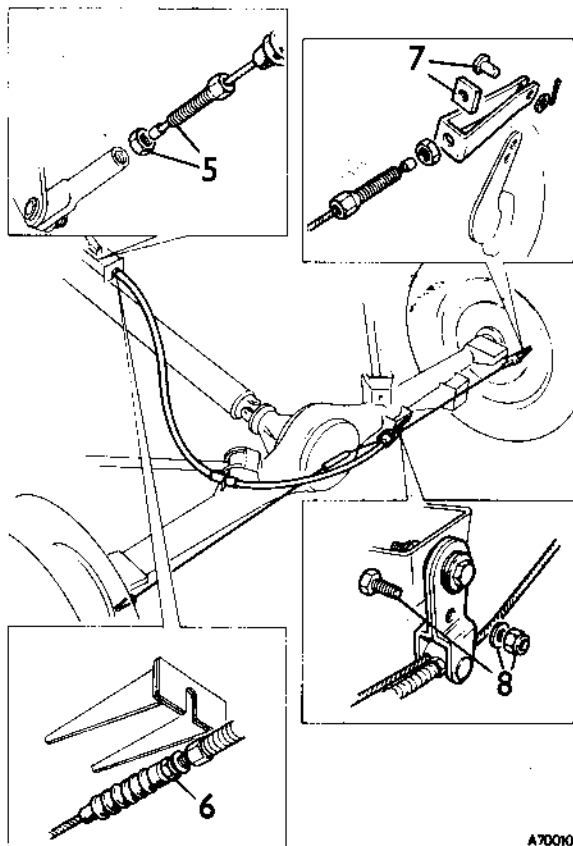

A70010

- 7 Remove the split pin, washer and clevis pin retaining the cable to each rear brake operating lever.
- 8 Remove the trunnion locating nut, spring washer and bolt.
- 9 Slacken the nut securing the compensating levers.
- 10 Remove the cable assembly from the compensating levers, and the retaining brackets.

**Refitting**

- 11 Reverse instructions 1 to 10.
- 12 Adjust the hand brake cable, see 70.35.10.

**FRONT BRAKE PADS**

Remove and refit 70.40.02

**Removing**

- 1 Jack up the car and remove the front road wheel.
- 2 Depress the pad-retaining spring and withdraw the split pins.
- 3 Taking note of their positions, lift the pads and shims out of the caliper recesses.  
The shims need not be renewed provided they are undamaged and are not corroded.

**Refitting**

- 4 Ease the caliper pistons into the bores to provide the extra clearance to accommodate the new unworn brake pads. During this operation brake fluid will be displaced and to prevent the reservoir overflowing, open the caliper bleed screw as pressure is applied to the piston. Close the bleed screw when the piston has moved the required amount. Repeat on the opposite piston in the caliper.
- 5 Remove dust and clean the brake pad locations in the caliper.
- 6 Insert the new pads and shims (smaller cut-out uppermost) into the caliper recesses.
- 7 Fit the new pad-retaining spring and split pins.
- 8 Firmly depress the foot brake pedal several times to correctly locate the friction pads.
- 9 Fit the road wheel and lower the car.
- 10 Check the fluid level in the reservoir and top up as necessary.

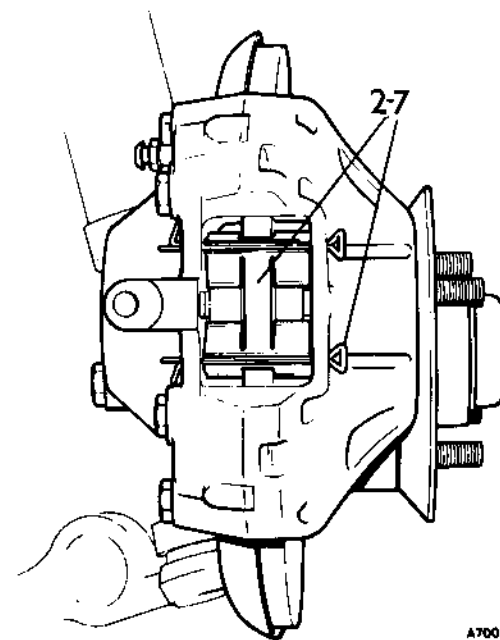

A70011

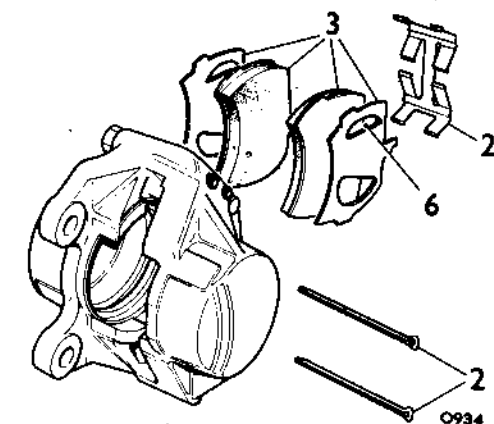

O934

## REAR BRAKE-SHOES

### Remove and refit

70.40.03

#### Removing

- 1 Jack up the car and support the body on stands.
- 2 Remove the road wheel.
- 3 Release the hand brake.
- 4 Remove the two countersunk screws securing the brake-drum and withdraw the brake-drum.

When brake-drum removal is found to be difficult due to wear or ridging, remove the rubber plug on the inboard side of the backplate. Insert a small screwdriver, and engage it in the slotted hole in the small adjusting lever. Press down to release the mechanism.

- 5 Carefully note the position of the shoes and springs.
- 6 Remove the shoe steady pin cups and springs and extract the shoe steady pin from the rear of the backplate.
- 7 Ease the toe of the leading shoe followed by the heel of the trailing shoe out of the slotted piston heads.
- 8 Unlock the pull-off springs, and the cross lever tension spring and remove the brake-shoes.

To avoid possible ejection of the wheel cylinder pistons restrain them in position with a twist of wire or a suitable clamp. Take care not to damage the rubber boots.

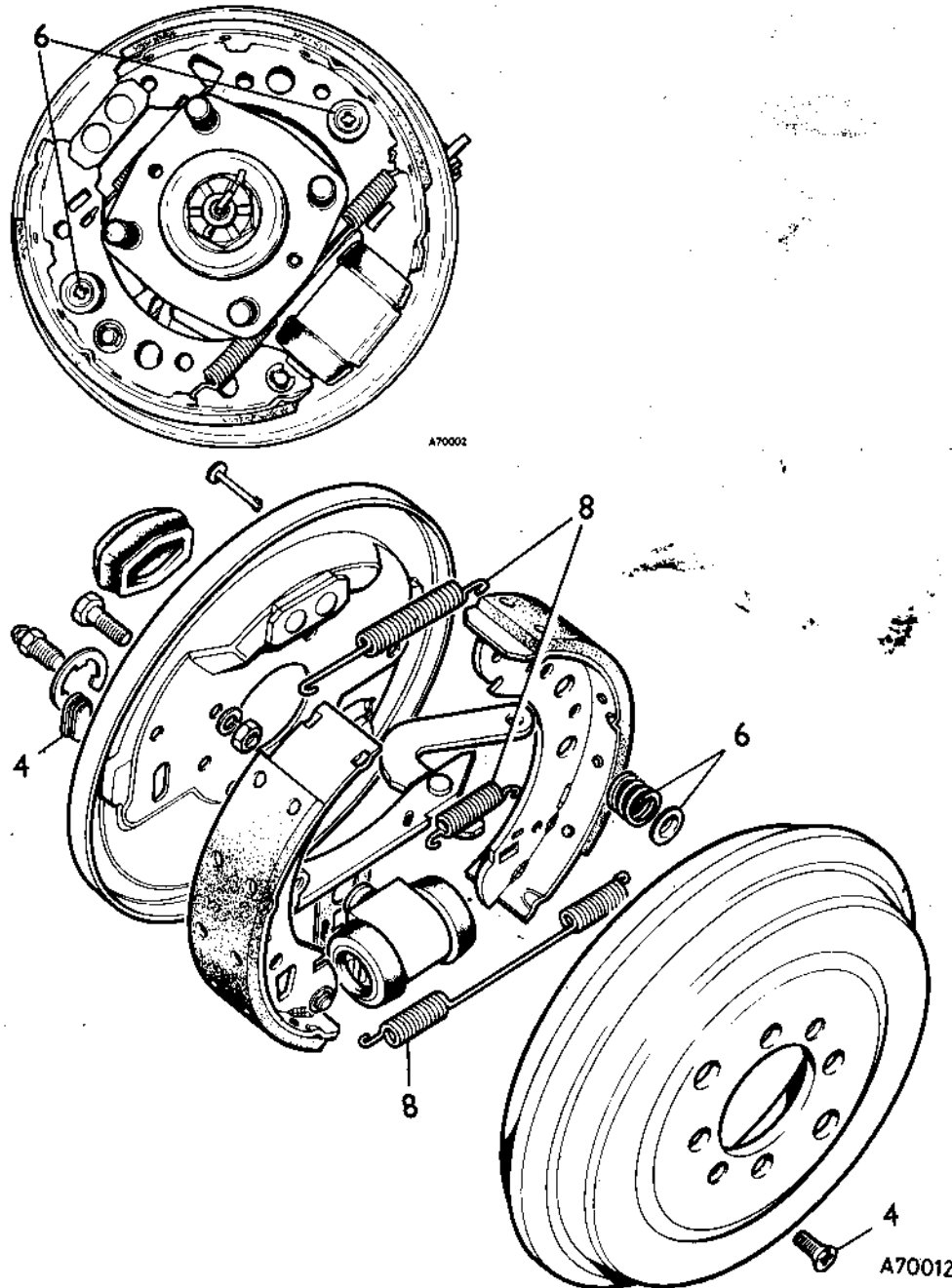

#### Refitting

- 9 Insert the cross lever tension spring hook in the cross lever, engage the other end in the leading shoe web in the previously noted hole position. This spring is not interchangeable with the spring on the opposite brake.
- 10 Ease the brake-shoe and the cross lever towards the backplate, engage the toe of the shoe into the slot in the piston and the heel of the shoe into the abutment.
- 11 Hold the cross lever and shoe against the backplate, fit the steady pin, spring and cup.
- 12 Hook the pull-off springs into the holes in the shoe webs. The spring nearest the abutment is fitted on the backplate side of the shoes.
- 13 Pull the trailing shoe against the resistance of the springs. Position the heel into the slot in the piston and the toe into the abutment. Ensure that the cut-out in the cross lever engages with the slot in the adjuster plate.
- 14 Fit the remaining steady pin, spring and cup.
- 15 The functioning of the adjuster can be checked by gently operating the foot brake with the drum removed. Following expansion of the brake-shoes the ratchet will be seen to operate. Brake-shoes expansion can be cancelled by raising the ratchet plate to separate the ratchet teeth and allowing the pull-off springs to retract the shoes.
- 16 Replace the brake-drum and road wheel. Lower the car.
- 17 Apply the foot brake heavily several times to centralize and adjust the brake-shoes.
- 18 Road-test the car. If the operation of the brakes, including the hand brake, is poor, make four brake applications applying moderately high pedal efforts to decelerate the vehicle from 20 m.p.h. to rest. This will ensure correct adjustment of the rear brakes.

**SERVO****Remove and refit****70.50.01****Removing**

- 1 Remove the master cylinder from the servo, see 70.30.01.
- 2 Disconnect the vacuum hose from the non-return valve.
- 3 Remove the clevis pin securing the servo push-rod to the brake pedal.
- 4 Remove the four nuts and spring washers securing the servo to the pedal bracket.
- 5 Withdraw the servo.

**Refitting**

- 6 Reverse instructions 1 to 5.
- 7 Bleed the brakes.

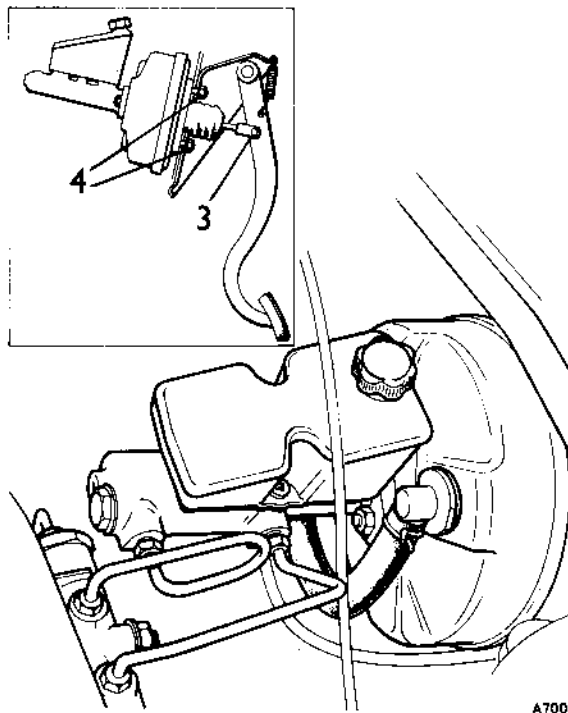

A70013

**VACUUM HOSE****Remove and refit****70.50.14****Removing**

- 1 Release the vacuum hose clips at the manifold and the servo non-return valve.
- 2 Remove the hose from the manifold and the non-return valve.

**Refitting**

- 3 Reverse instructions 1 and 2.

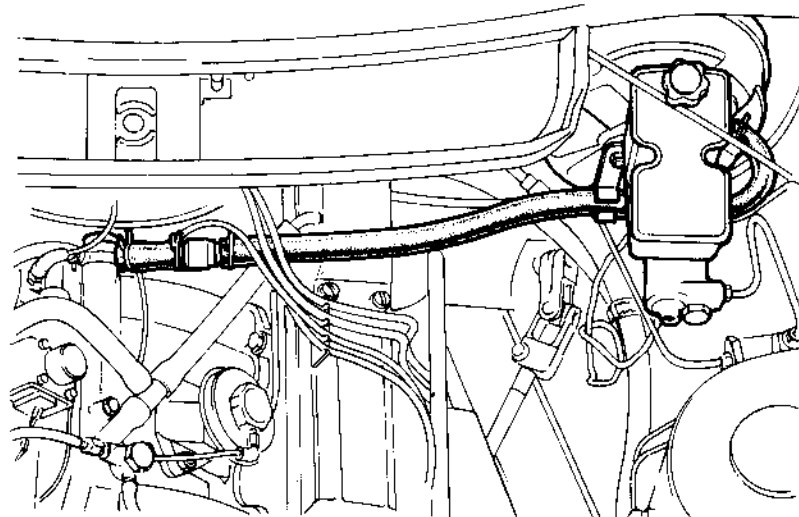

A70016

**NON-RETURN VALVE****Remove and refit****70.50.15****Removing**

- 1 With the engine stopped, depress the brake pedal to destroy the vacuum in the servo.
- 2 Release the hose clip securing the vacuum hose to the non-return valve and disconnect the hose.
- 3 Withdraw the non-return valve from the servo.

**Refitting**

- 4 Renew the sealing rubber as necessary, and press the non-return valve into position in the servo.
- 5 Connect the vacuum hose to the non-return valve and secure with the hose clip.

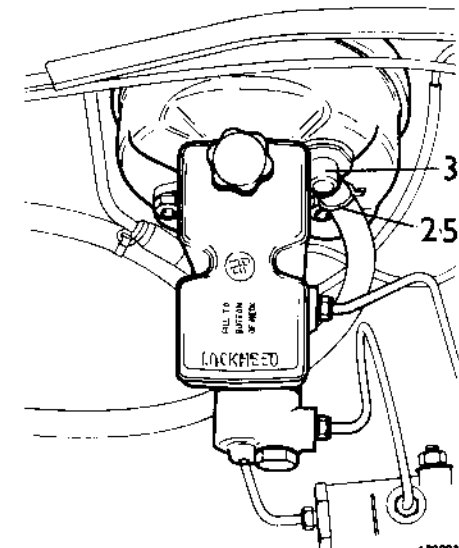

A70015

## SERVO FILTER

Remove and refit

70.50.25

### Removing

- 1 Remove the brake stop light switch.
- 2 Remove the split pin, plain washer and clevis pin securing the servo rod to the brake pedal.
- 3 Remove the rubber boot from the push-rod.
- 4 Withdraw the filter.

### Refitting

- 5 Reverse instructions 1 to 4.

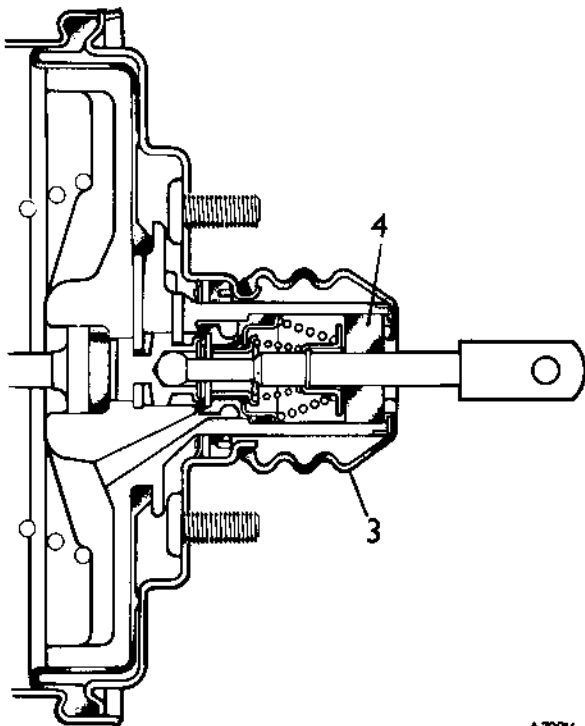

A 70014

## BRAKE CALIPER – FRONT

Remove and refit

70.55.02

### Removing

- 1 Jack up the car and remove the front wheel.
- 2 Disconnect the brake union at the caliper and seal the fluid connections to prevent entry of grit.
- 3 Remove the two bolts and spring washers retaining the steering-arm and the caliper lower mounting lug to the stub axle assembly.
- 4 Push the steering-arm clear.

- 5 Remove the bolt and spring washer securing the caliper upper mounting lug to the stub axle assembly.
- 6 Withdraw the caliper.

### Refitting

- 7 Engage the caliper on the disc and align the locating lugs.
- 8 Position the upper bolt and spring washer; do not tighten.
- 9 Fit the steering-arm to the stub axle assembly.
- 10 Tighten the three bolts.
- 11 Bleed the brakes.
- 12 Fit the road wheel and remove the jack.

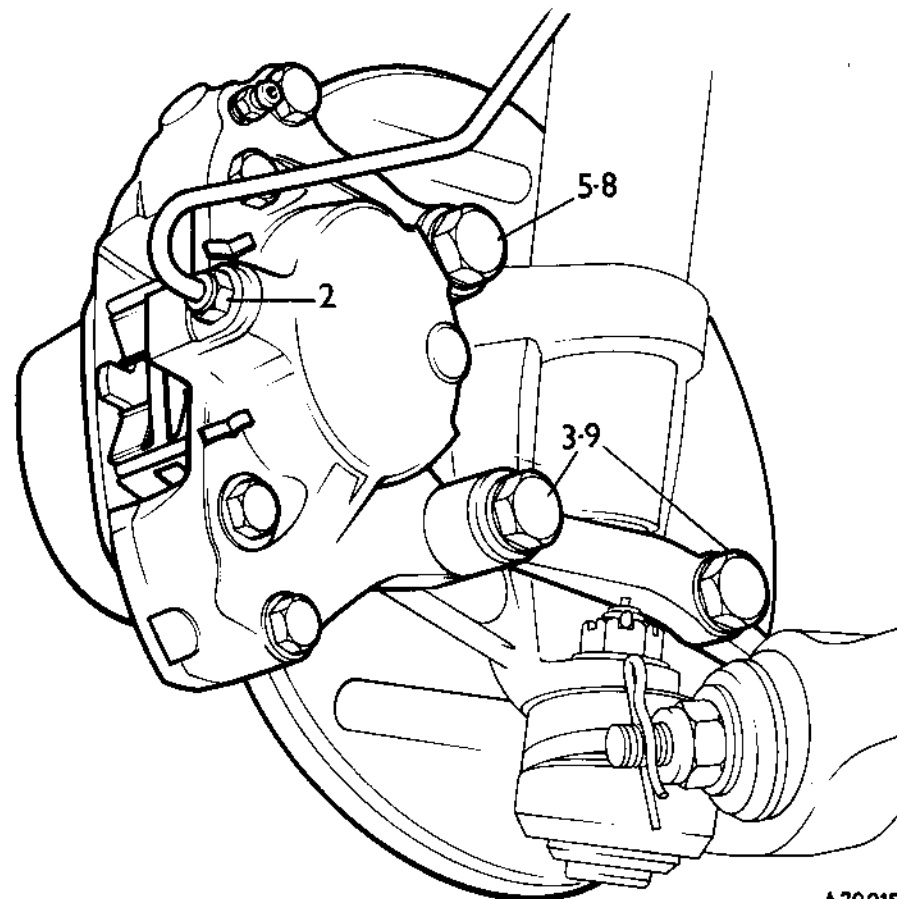

A 70015

**FRONT CALIPER**

Renew seals 70.55.13

**Dismantling**

- 1 Remove the caliper from the car, see 70.55.02.
- 2 Remove the brake pads and shims, see 70.40.02.
- 3 Extract the caliper pistons. Piston removal may be affected by using a low pressure air line. DO NOT interchange the pistons. If either piston is seized, the whole caliper assembly must be renewed.
- 4 Using a blunt screwdriver carefully prise out the wiper seal retainers, taking care not to damage the seal grooves in the caliper bores.
- 5 Extract the wiper dust seal and the fluid seal from each caliper bore.
- 6 Thoroughly clean the caliper pistons and caliper bores with new clean brake fluid or methylated spirit.
- 7 Carefully inspect the caliper bores and pistons. If they show any signs of corrosion, fault or wear, the parts affected must be renewed.

**Reassembling**

- 8 Fit the new fluid seals, using only the fingers, into the grooves in the caliper bores, ensuring that they are properly located. The fluid seal grooves and the seals are not the same in section, therefore even when located correctly the seal feels proud at the edge farthest away from the mouth of the caliper bore.
- 9 Lubricate the bores with new, clean brake fluid.
- 10 Squarely insert the pistons into the caliper bores. Leave approx.  $\frac{1}{8}$  in (7.94 mm) of each piston projecting from the mouth of each bore.
- 11 Fit a new wiper seal into each of the seal retainers and slide the assemblies, seal first, carefully into the mouth of each bore using the pistons as a guide.
- 12 Carefully press home the seals, taking care not to distort the retainers.
- 13 Push home the pistons.

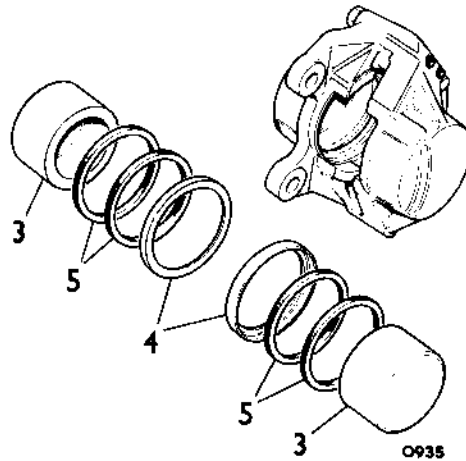

- 14 Fit the caliper to the car, see 70.55.02.
- 15 Fit the brake pads and shim(s), see 70.40.02.
- 16 Bleed the brakes.

**REAR WHEEL CYLINDER**

Remove and refit 70.60.18

**Removing**

- 1 Jack up the car and support the body on stands.
- 2 Remove the rear wheel.
- 3 Remove the brake-drum, see 70.10.03.
- 4 Remove the brake-shoes, see 70.40.03.
- 5 Disconnect the hand brake cable at rear of the backplate.
- 6 Disconnect the fluid feed pipe union at the wheel cylinder and remove the bleed screw (left-hand side only);  
or  
Disconnect the fluid feed and transfer pipe unions at the wheel cylinder (right-hand side only).

- 7 Remove the spring clip securing the wheel cylinder to the rear of the backplate.
- 8 Remove the wheel cylinder and gasket.

**Refitting**

- 9 Reverse instructions 1 to 8, fitting a new gasket and circlip.
- 10 Apply the foot brake several times to adjust the rear brakes.
- 11 Bleed the brakes.
- 12 Road-test the car. If the operation of the brakes, including the hand brake, is poor, make four brake applications applying moderately high pedal efforts to decelerate the vehicle from 20 m.p.h. to rest. This will ensure correct adjustment of the rear brakes.

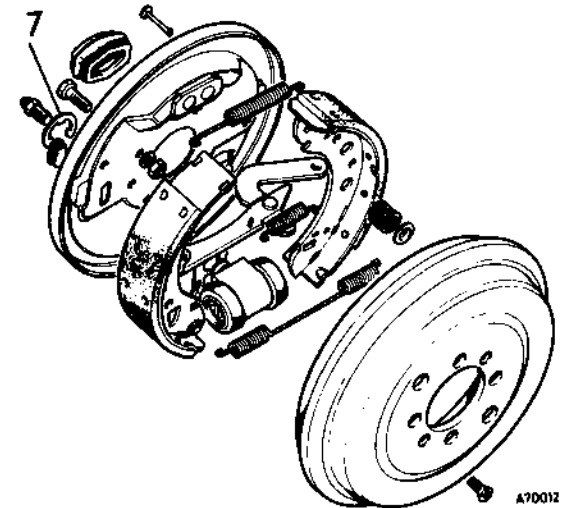



## REAR WHEEL CYLINDER

Overhaul

70.60.26

- 1 Remove the wheel cylinder from the backplate, see 70.60.18.
- 2 Remove the rubber boots from the cylinder body and remove the pistons.
- 3 Withdraw the pistons from the bore and retrieve the spring located between the two pistons.
- 4 Carefully inspect all components for faults and wear. A replacement wheel cylinder assembly must be fitted if, after cleaning, the bore of the old unit shows the slightest signs of corrosion or scoring.
- 5 Smear the cylinder bore with clean brake fluid.
- 6 Renew the seal on each piston, carefully fit the seal into the larger groove on each piston, with the lip of the seal facing away from the slotted head.
- 7 Locate the rubber boots into the smaller groove on each of the pistons.
- 8 Insert the pistons into the cylinder bore ensuring that the spring locates between them in the counter-bored ends.
- 9 Refit the wheel cylinder, see 70.60.18.

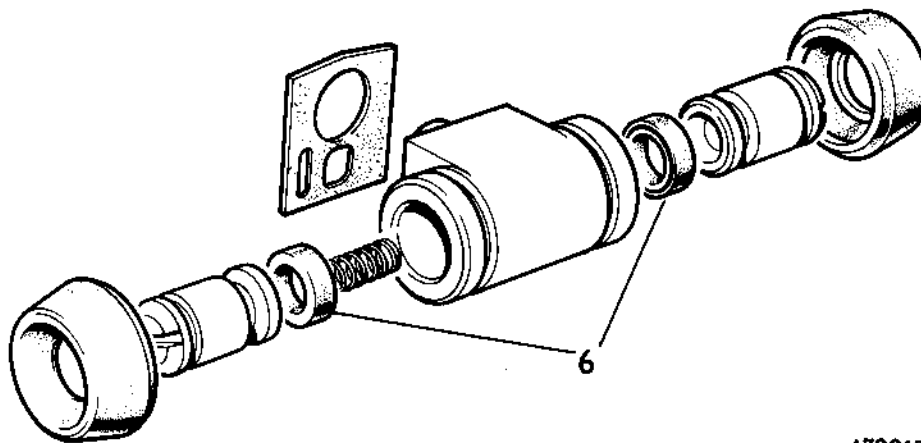

A70017

# BODY UNIT

## Alignment check

76.10.01

- 1 A preliminary check of the alignment should be carried out by dropping a plumb-bob from the centre of the points A, B, C, D on each side of the car.
- 2 Establish a centre line by means of a large pair of compasses at points B and D.
- 3 Check measurements against those given in DATA.
- 4 Construct diagonals.

Incorrect alignment will be evident by the failure of the diagonals to intersect on the centre line by considerable deviation from the dimensions given.

### DATA

A	B	C	D
552 mm (21.73 in)	594 mm (23.38 in)	964 mm (37.95 in)	1042 mm (41.02 in)

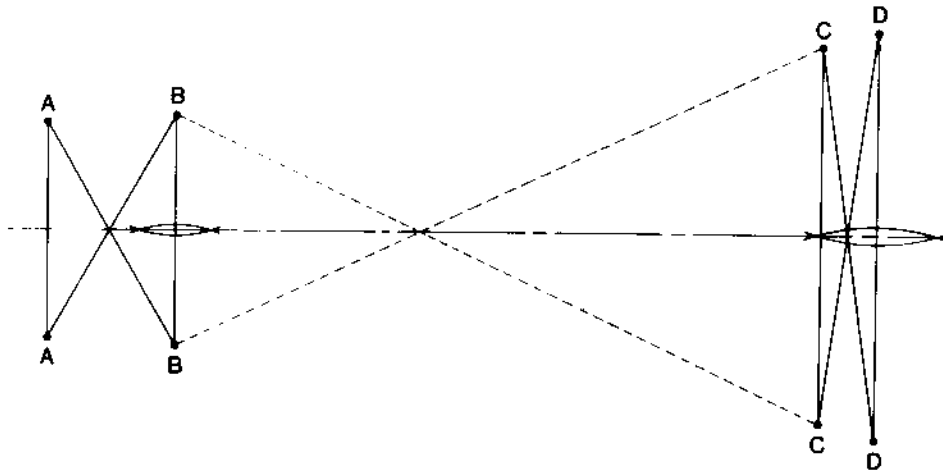

A76053

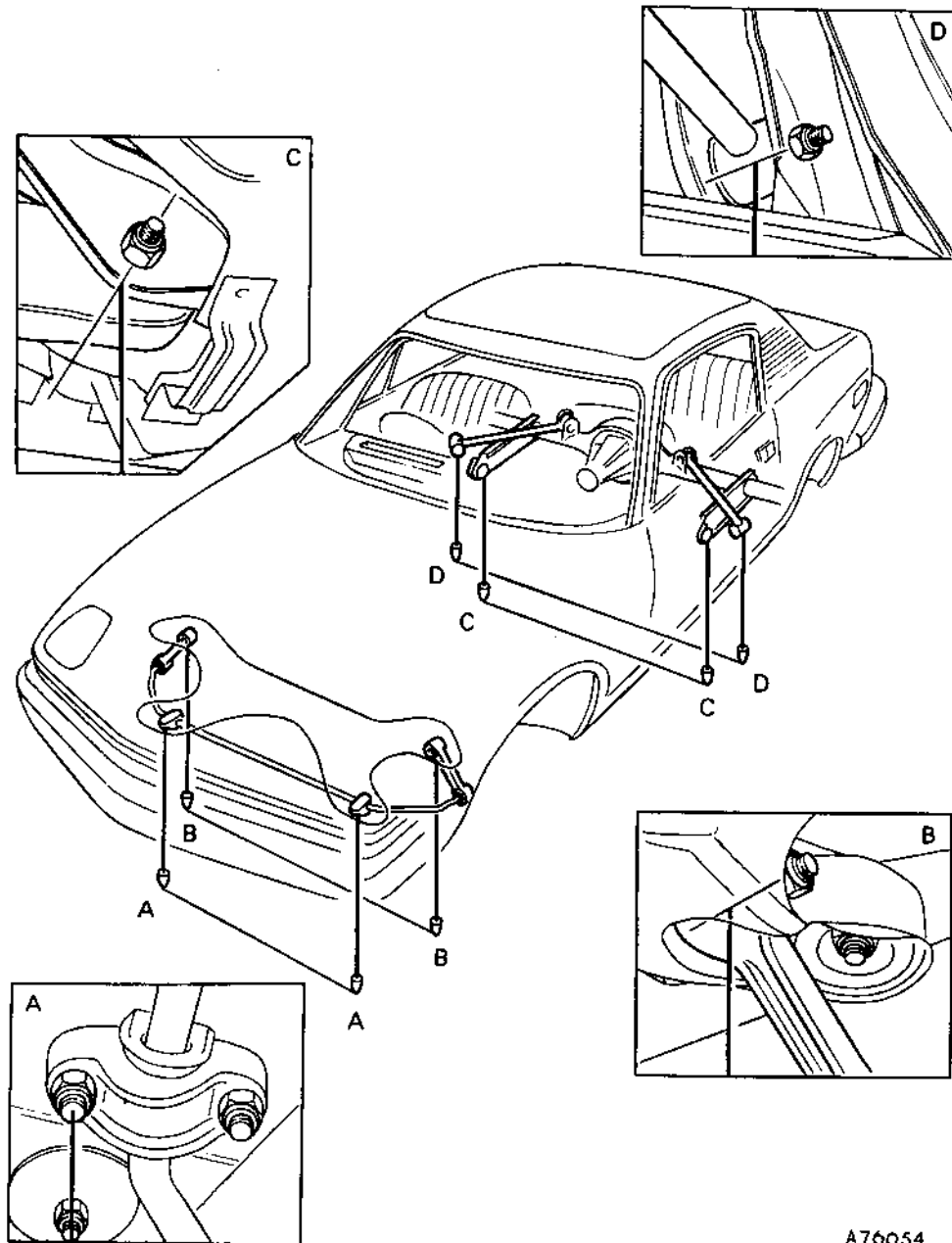

A76054

continued

### Vertical alignment

The dimensions given below are for cars in showroom condition, unladen and without fuel. It should be noted that the important point is the relative positions of the vertical datum points to each other and not their actual height from the wheel hub centres.

Code	Dimension	Location	Code	Dimension	Location
A	346 mm (13.62 in)	Anti-roll bar front mounting to suspension pod cap	c	571 mm (22.48 in)	Lower link to front suspension pod cap
B	141,5 mm (5.57 in)	Rear suspension arm mounting to radius rod mounting	d	476.5 mm (18.75 in)	Front suspension pod cap to datum line
a	33 mm (1.29 in)	Anti-roll bar clamp front fixing bolt to lower link	e	338 mm (13.3 in)	Top of wheel arch to datum line
b	361 mm (14.20 in)	Top of front wheel arch to wheel hub centre – Europe – 4 speed gearbox	f	136 mm (5.35 in)	Rear suspension arm mounting to radius rod mounting
	356 mm (14.02 in)	Top of front wheel arch to wheel hub centre – Europe – 5 speed gearbox	g	95 mm (3.74 in)	Rear suspension arm mounting to datum line
	353 mm (13.90 in)	Top of front wheel arch to wheel hub centre – Europe – Automatic transmission	h	319 mm (12.56 in)	Top of rear wheel arch to datum line
	354 mm (13.96 in)	Top of front wheel arch to wheel hub centre – USA – 4 speed gearbox	j	348 mm (13.71 in)	Top of rear wheel arch to wheel hub centre – Europe – 4 speed gearbox
	350 mm (13.78 in)	Top of front wheel arch to wheel hub centre – USA – 5 speed gearbox		350 mm (13.80 in)	Top of rear wheel arch to wheel hub centre – Europe – 5 speed gearbox
	347 mm (13.67 in)	Top of front wheel arch to wheel hub centre – USA – Automatic transmission		345 mm (13.60 in)	Top of rear wheel arch to wheel hub centre – Europe – Automatic transmission
	356 mm (14.02 in)	Top of front wheel arch to wheel hub centre – USA – 4 speed gearbox – air conditioning		346 mm (13.63 in)	Top of rear wheel arch to wheel hub centre – USA – 4 speed gearbox
	352 mm (13.88 in)	Top of front wheel arch to wheel hub centre – USA – 5 speed gearbox – air conditioning		348 mm (13.72 in)	Top of rear wheel arch to wheel hub centre – USA – 5 speed gearbox
	349 mm (13.75 in)	Top of front wheel arch to wheel hub centre – USA – Automatic transmission – air conditioning	Z-Z	343 mm (13.52 in)	Top of rear wheel arch to wheel hub centre – USA – Automatic transmission
					Datum line

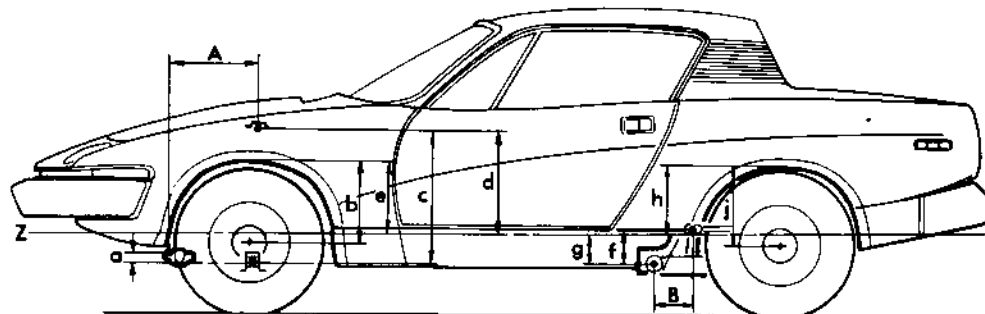

A 76162

**BODY UNIT****Alignment check 76.10.01**

(Using Churchill 700 or 707 system)

Whilst severe underframe damage is readily detected, less serious damage may cause distortion that is not visually apparent. If steering or suspension checks indicate a fault which cannot be attributed to anything other than underframe distortion, initial checking should be carried out to determine the area and extent of distortion.

**Initial check**

- 1 Clip the location tape to the right-hand side of the jig and make a chalk mark on the floor at each required location for initial checking.
- 2 Remove the tape to avoid damage.
- 3 Position the car centrally over the jig with the front wheel centres approximately 76 cm (30 in) from the front of the jig.

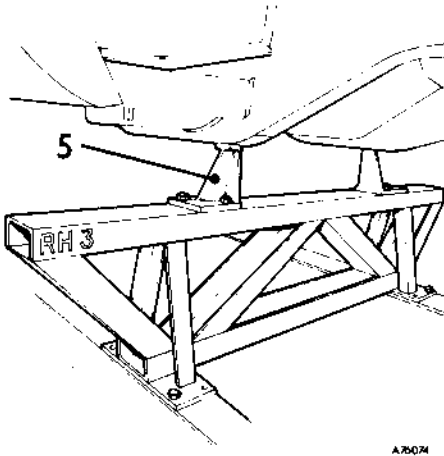

- 4 Raise the front of the car and fit transverse member number 3 to the jig with the rear mounting holes at tape position 12/7.
- 5 Fit brackets S700-39/1 (LH) and S700-39/2 (RH) to the transverse member, locating the inner bolt in hole J.

- 6 Lower the car to locate the bracket pegs in the front tooling holes in the floor side-member.
- 7 Raise the rear of the car by jacking under the differential.

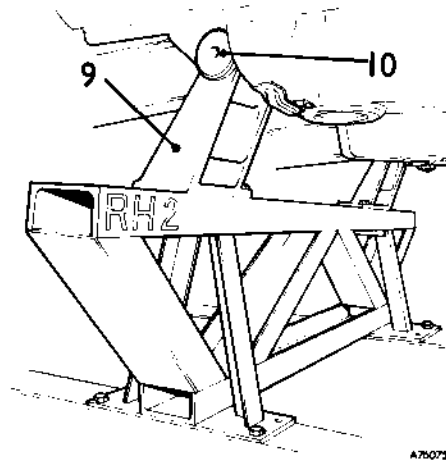

- 8 Fit transverse member number 2.
- 9 Fit brackets S700-29/1 (LH) and S700-29/2 (RH) to the transverse member, locating the inner bracket bolts in holes 'L'.  
**NOTE:** These holes are not marked on Churchill 700 systems. Distance across bolt centres should be 819 mm (32.25 in).
- 10 Lower the car and fit the two bushes S700-29/4 over the trailing arm hanger bolt heads.
- 11 Fit transverse member number 4 with the rear mounting holes at tape position 18.

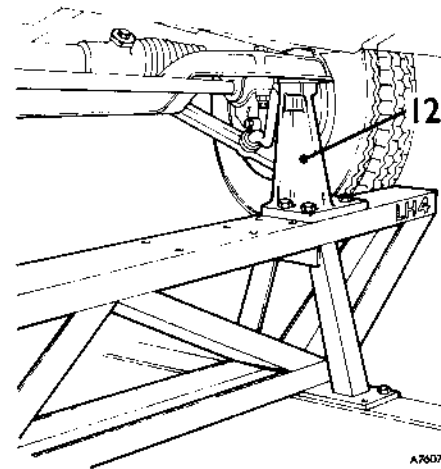

- 12 Fit bracket S700-401/1 (LH) and S700-401/2 (RH) locating the inner bracket bolts in holes 'G'.

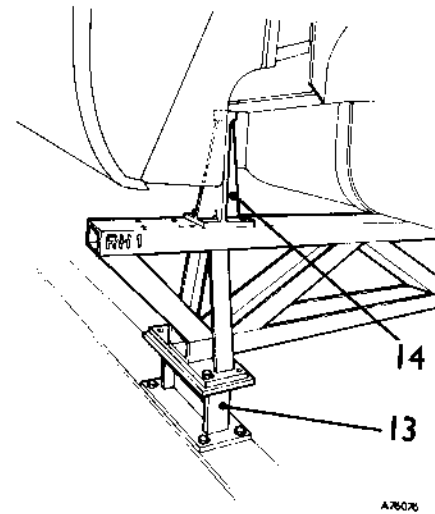

- 13 Fit risers S700-2B and transverse member number 1 with the rear mounting holes at tape position 4/28.
- 14 Fit brackets S700-19 (LH) and S700-19/2 (RH) locating the outer bracket bolts in holes 'B'.  
**NOTE:** These holes are not marked on Churchill 700 systems. Distance across bolt centres should be 952 mm (37-50 in).

The following operations are only necessary if repairs are required.

**Repair Stage**

It may not be necessary to fit the full set of repair brackets. If damage is confined to the front end of the car, repair brackets can be fitted at the front and the initial check brackets retained at the rear or vice-versa in the case of rear end damage. Where it is necessary to remove sub-assemblies before fitting repair brackets, reference should be made to the appropriate workshop manual section. For front end repairs, the transverse members and brackets used for initial checking are used again in their original positions with the following additions:-

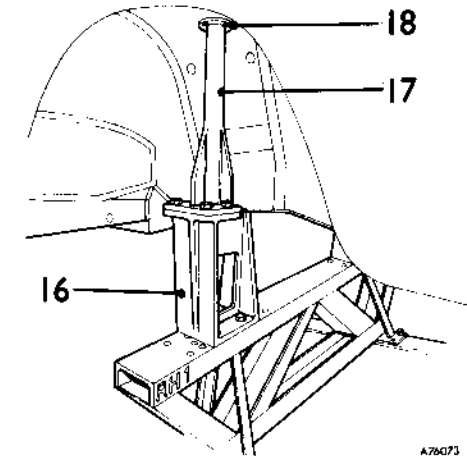

- 15 Fit transverse member number 1 with the rear mounting holes at tape position 15.
- 16 Fit risers S700-17/1 (LH) and S700-17/2 (RH).
- 17 Fit brackets S700-18/1 (LH) and S700-18/2 (RH) to the risers, using the eight screws supplied.
- 18 Secure the brackets to the spring turrets, using the damper attachment nuts.

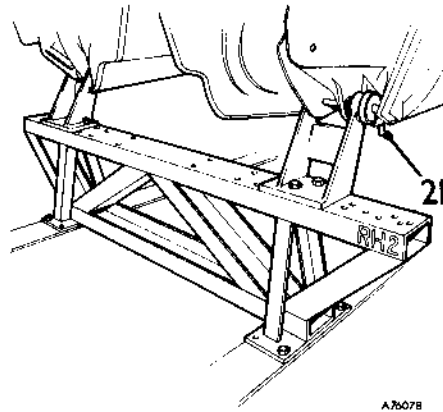

A76078

For rear end repairs:-

- 21 Remove the two bushes S700-29/4 and the two bolts and nuts from the trailing arm hangers. Refit the bushes and fit the two pins S700-29/5.

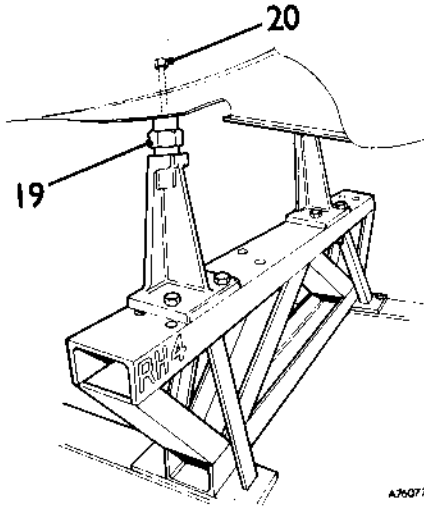

A76077

- 19 Fit adaptors S700-401/3 into brackets S700-401/1 (LH) and S700-401/2 (RH).
- 20 Install the two original bolts through the sub-frame front mounting holes in the longitudinal members and screw them into the adaptors.

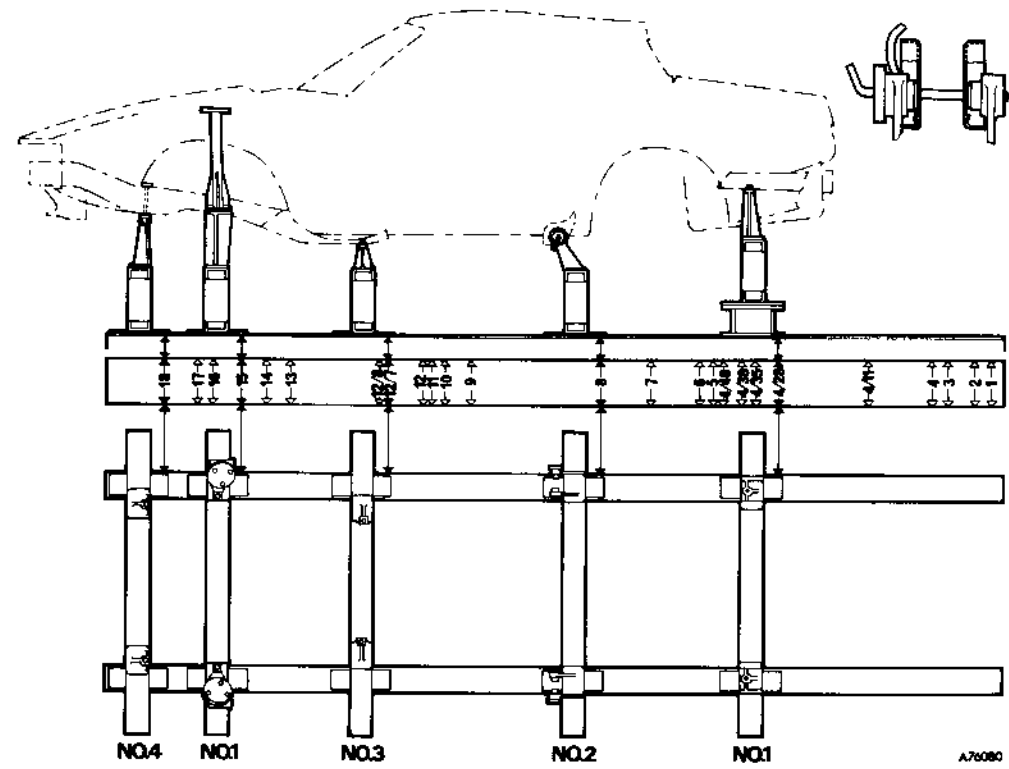
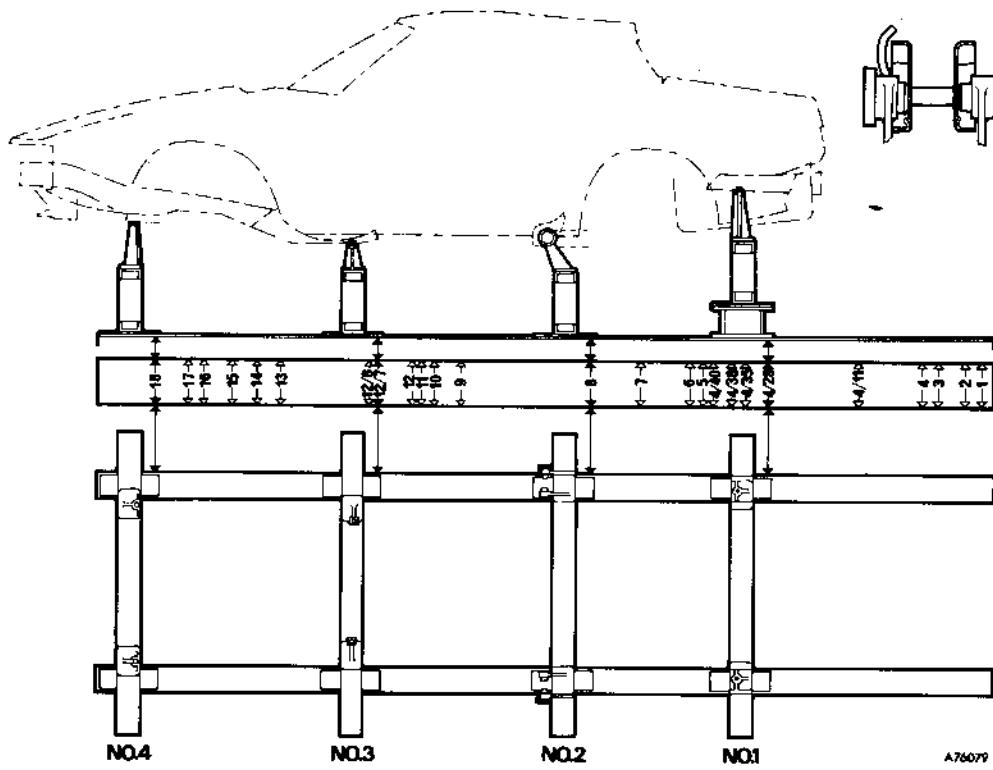

Transverse member locations for initial check

Transverse member locations for repair

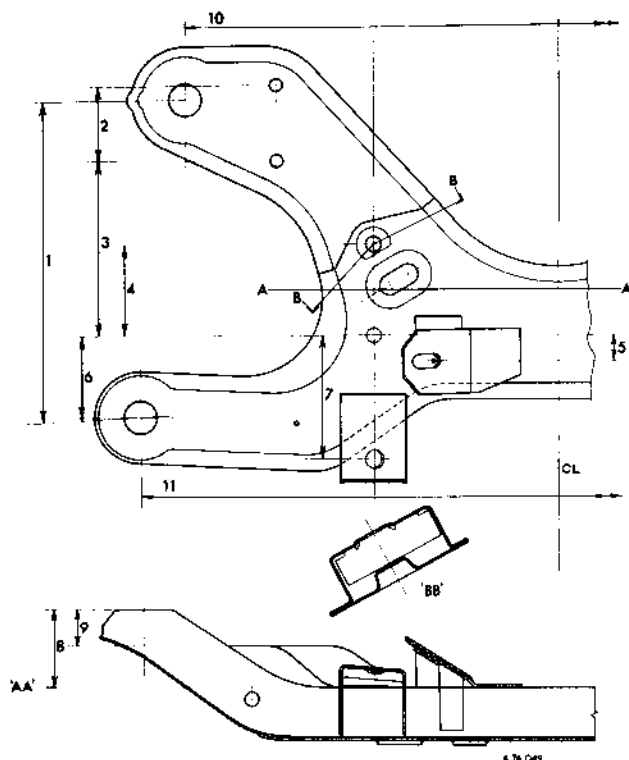

### SUB FRAME

Alignment check

Diagram Number	Millimetres	Inches
AA Datum line		
BB Datum face		
CL Centre line		
1	310 ± 0.50	12.20 ± 0.020
2	74 ± 0.25	2.91 ± 0.010
3	171 ± 1	6.73 ± 0.040
4	88 ± 0.25	3.46 ± 0.010
5	25 ± 0.50	0.98 ± 0.020
6	78 ± 1	3.07 ± 0.040
7	118.5	4.64
8	75 ± 1	2.95 ± 0.040
9	36 ± 1	1.41 ± 0.040
10	730 ± 0.50	28.74 ± 0.020
11	812 ± 0.50	31.96 ± 0.020

76.10.04

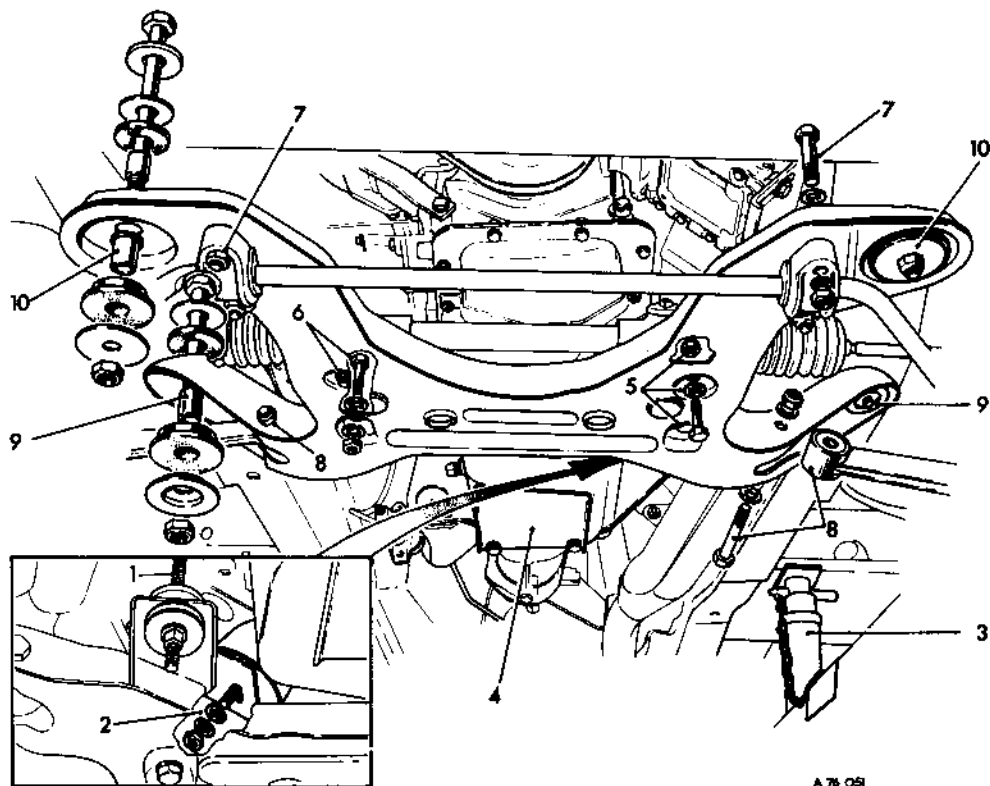

### SUB-FRAME

Remove and refit

76.10.29

#### Removing

- 1 Remove the engine stabilizer, see 12.45.16.
- 2 Remove the nut, spring washer and plain washer securing the engine mounting bracket to the sub-frame.
- 3 Jack up the front of the vehicle sufficiently to take the weight of the body off the front suspension.
- 4 Support the engine by placing a jack under the sump coupling plate.
- 5 Remove the two bolts, spring washers and plain washers securing the pinion end of the steering rack to the sub-frame.
- 6 Remove the two nuts, bolts and plain washers securing the steering rack to the sub-frame.

- 7 Remove the four nuts, bolts, spring washers, plain washers and mounting brackets securing the anti-roll bar to the sub-frame.
- 8 Remove the two nuts, spring washers and plain washers securing the lower links to the sub-frame. Adjust the jacks if necessary to ensure that the bolts are not under load. Withdraw the two bolts and release the lower links from the sub-frame.
- 9 Remove the two nuts, retainers, mounting rubbers and sleeves securing the rear of the sub-frame to the body.
- 10 Support the sub-frame and remove the two nuts, retainers, mounting rubbers and sleeves securing the front of the sub-frame to the body.
- 11 Lower the sub-frame and remove it from the vehicle.

continued

- Refitting**
- 12 Position the sub-frame on the mounting bolts ensuring that the four mounting rubbers and washers are correctly positioned between sub-frame and body.
  - 13 Tighten the nuts 10 and 9 to torque figures given in 'TORQUE WRENCH SETTINGS'.
  - 14 Reverse instructions 2 to 8.
  - 15 Refit and adjust the engine tie-rod, see 12.45.16.

**REAR QUARTER TRIM PAD**

Remove and refit 76.13.12

- Removing**
- 1 Pull the weatherstrip away from the door aperture in the area of the trim pad.
  - 2 Carefully pull the trim pad edging away from the body flange.
  - 3 Remove the cap, screw and retainer.
  - 4 Prise off the trim pad - 5 clips.

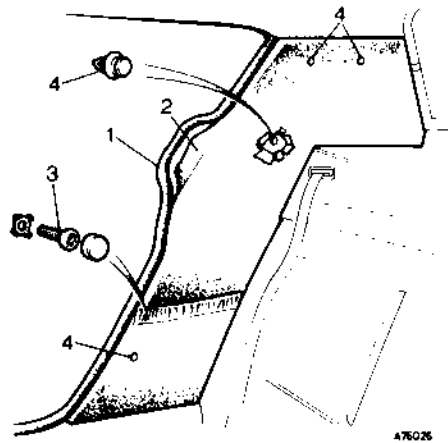

**REAR COMPARTMENT TRIM PAD**

Remove and refit 76.13.20

- Removing**
- 1 Move both seats and seat squabs to the fully forward position.
  - 2 Open the rear console lid and remove the two screws and plain washers securing the console and trim pad to the body.
  - 3 Remove the two screws and cup washers securing the trim pad to the body.
  - 4 Remove the four screws and cup washers securing the parcel tray and the trim pad to the body.
  - 5 Carefully raise the forward edge of the parcel tray, raise the trim pad clear of the console and remove it from the car.

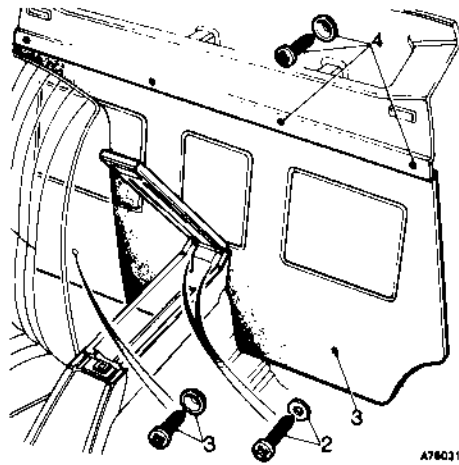

- Refitting**
- 6 Reverse instructions 1 to 5.

- Refitting**
- 5 Reverse instructions 1 to 4, using Dunlop SP758 adhesive on the mating surfaces of trim pad edging and body flange.

**BONNET**

Remove and refit 76.16.01

- Removing**
- 1 Pull the tubing from the screenwasher pump; attach a suitable length of string to the end of the tubing to facilitate refitting, and pull the tubing through the holes in the inner wheel arch.
  - 2 Mark the hinge positions on the body.
  - 3 Support the bonnet and remove the two screws and spring washers securing the stay to the bonnet.
  - 4 Remove the four bolts securing the hinges to the adjuster plates and lift off the bonnet.

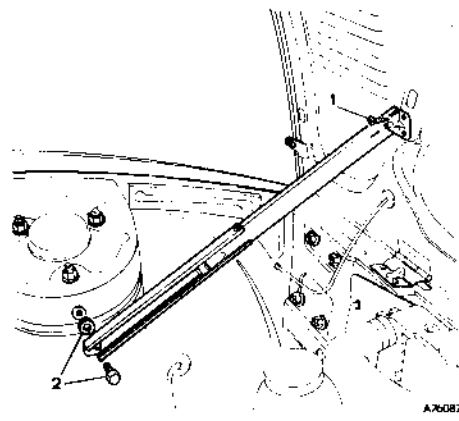

- Refitting**
- 3 Reverse instructions 1 and 2.

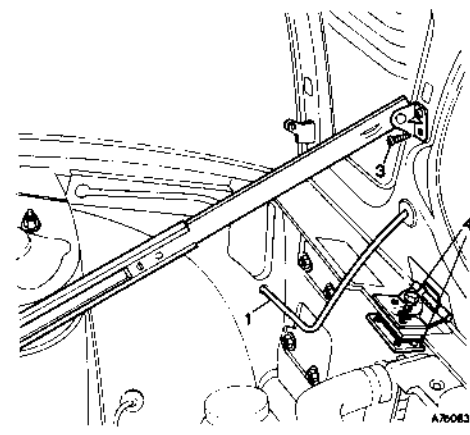

- Refitting**
- 5 Reverse instructions 1 to 4, adjusting if necessary to ensure correct alignment before fully tightening bolts 4.

**BONNET STAY**

Remove and refit 76.16.14

- Removing**
- 1 Support the bonnet and remove the two screws and spring washers securing the stay to the bonnet.
  - 2 Remove the bolt and spring washer securing the lower end of the stay to the body.

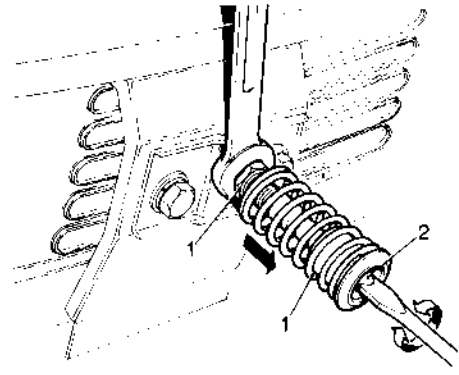

**BONNET CATCH**

Adjust 76.16.20

- To ensure positive locking and eliminate free movement at the closing face, adjust the bonnet catch as follows:
- 1 Pull back the spring and slacken the locknut at the base of the shaft.
  - 2 Using a screwdriver, screw the shaft in or out as required.
  - 3 Retighten the locknut.
  - 4 Check the bonnet closing action and repeat instructions 1 to 3 if necessary.

A76087

A76082

A76031

A76026

A76004



## BONNET LOCK

Remove and refit 76.16.21

### Removing

- 1 Remove the trunnion from the cable.
- 2 Slacken the pinch bolt and detach the cable from the lock.
- 3 Remove the four bolts, spring washers and plain washers securing the lock to the body.

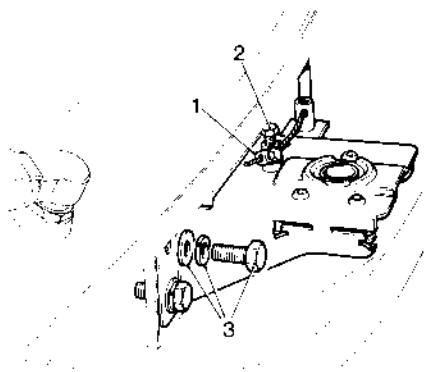

A76005

### Refitting

- 4 Reverse instructions 1 to 3.

## BONNET RELEASE CABLE

Remove and refit 76.16.29

### Removing

- 1 Remove the trunnion from the cable.
  - 2 Slacken the pinch bolt and detach the cable from the lock.
  - 3 Unscrew the nut securing the outer cable to the bracket beneath the facia.
  - 4 Withdraw the cable through the grommet on the bulkhead and collect the nut and shakeproof washer.
- CAUTION:** Do not close the bonnet with the cable removed or loose.

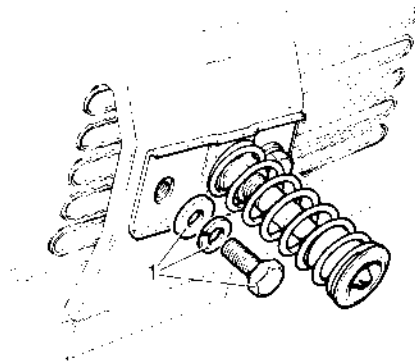

A76003

### Refitting

- 2 Refit in reverse order and adjust if necessary, see 76.16.20.

## BONNET CATCH

Remove and refit 76.16.34

### Removing

- 1 Remove the two bolts, spring washers and plain washers. Remove the catch from the bonnet.

### Refitting

- 5 Reverse instructions 1 to 4, ensuring that the lock release lever is not pre-loaded by the cable.

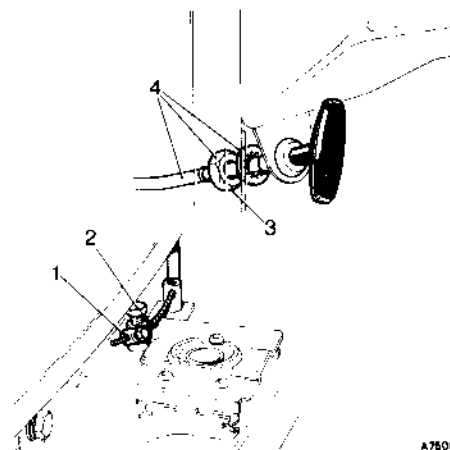

A76006

## LUGGAGE COMPARTMENT LID

Remove and refit 76.19.01

### Removing

- 1 Mark the hinge positions on the lid.
- 2 Disconnect the two rear number plate lamp leads from the connector at the R.H. side of the luggage compartment.
- 3 Support the lid and remove the two bolts securing the stay to the lid.
- 4 Remove the four bolts, spring washers and plain washers securing the lid to the hinges and lift off the lid.

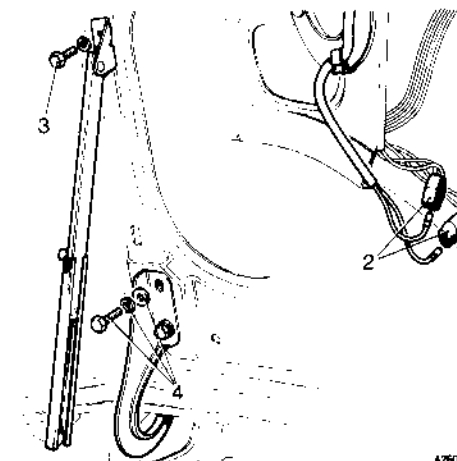

A76008

### Refitting

- 5 Reverse instructions 1 to 3, ensuring correct alignment of the lid in the horizontal plane before fully tightening bolts 4.

## LUGGAGE COMPARTMENT LID HINGES

Remove and refit 76.19.07

### Removing

- 1 Remove the luggage compartment lid, see 76.19.01.
- 2 Remove (two each side) the four bolts, spring washers and plain washers securing the hinges to the body and lift off the hinges.

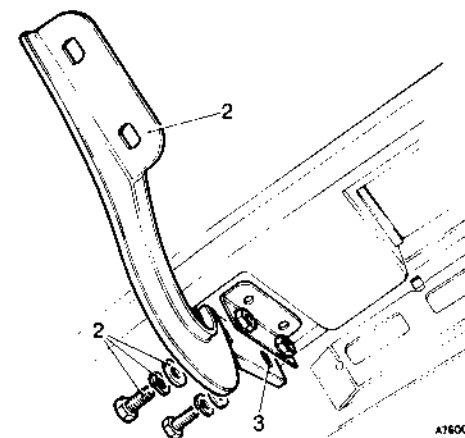

A76008

### Refitting

- 3 Reverse instructions 1 and 2 ensuring correct alignment in the vertical plane before fully tightening bolts 2.

## LUGGAGE COMPARTMENT LOCK

Remove and refit 76.19.11

### Removing

- 1 Remove the three bolts, spring washers and plain washers and lift off the latch.
- 2 Pull the spring clip to one side to disengage it from the lock.
- 3 Carefully withdraw the lock and gasket.

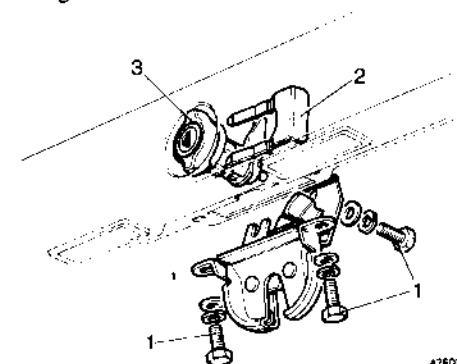

A76010

### Refitting

- 4 Reverse instructions 1 to 3.

**LUGGAGE COMPARTMENT LOCK STRIKER**

Remove and refit 76.19.12

- Removing**
- 1 Pull the weatherstrip away from the body panel in the area of the striker.
  - 2 Mark the position of the striker bolts on the body panel.
  - 3 Remove the three bolts, spring washers and plain washers.
  - 4 Withdraw the striker from the body panel aperture.

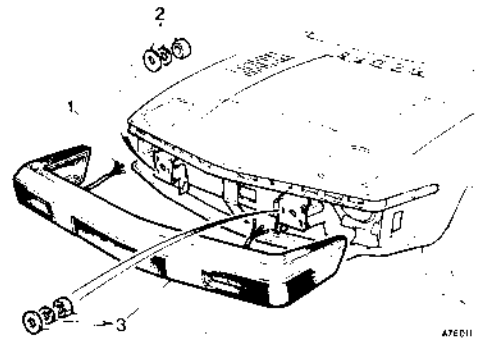
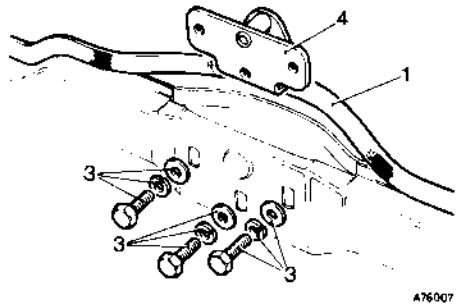

- Refitting**
- 4 Reverse instructions 1 to 3.

**BUMPER—REAR**

Remove and refit 76.22.15

- Removing**
- 1 Remove the four nuts, spring washers and plain washers securing the side support brackets to the bumpers.
  - 2 Remove the three nuts, spring washers and plain washers and lift off the handling brackets. — U.S.A. models.
  - 3 Support the bumper and remove the remaining two nuts, spring washers and plain washers. Lift off the bumper.

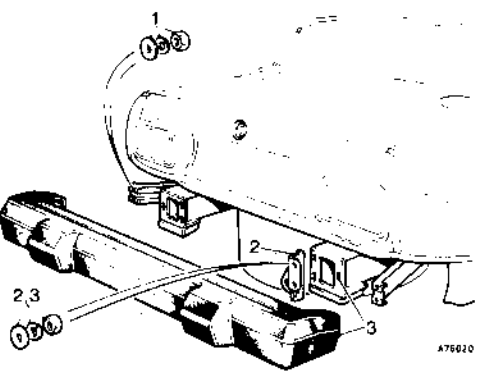

- Refitting**
- 4 Reverse instructions 1 to 3.

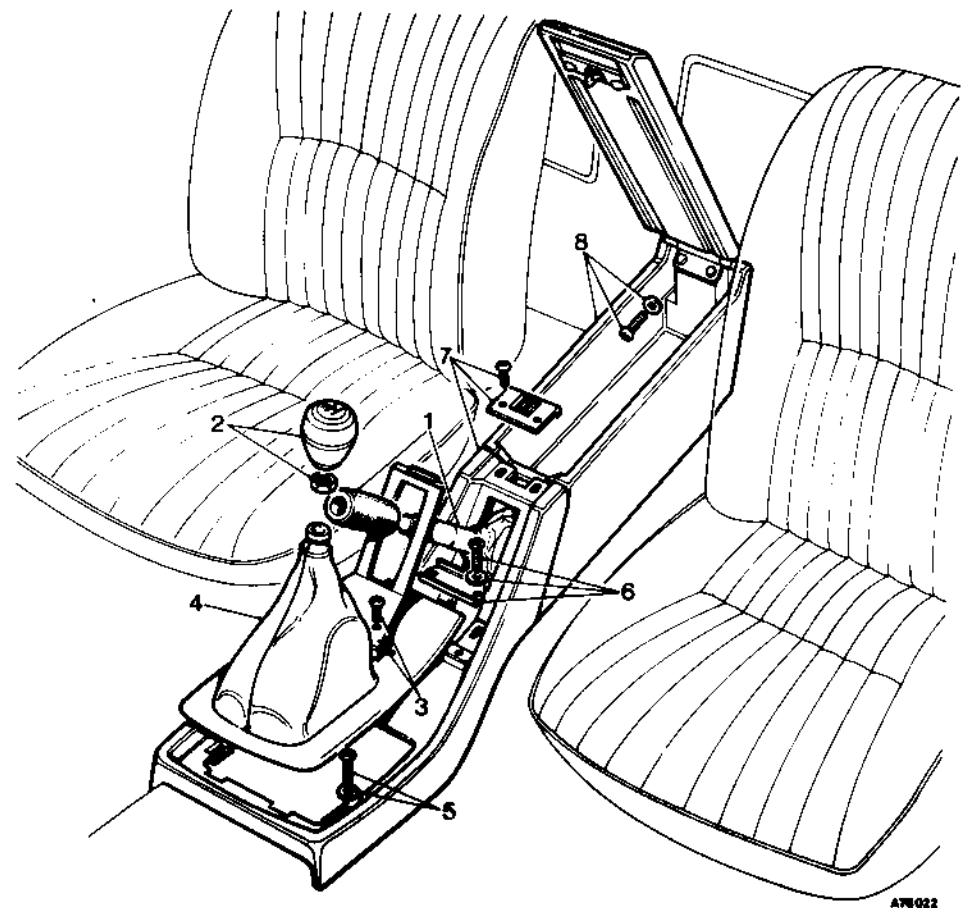

**CONSOLE ASSEMBLY**

Remove and refit 76.25.01

- Removing**
- 1 Raise the handgrip lever and pull off the grip.
  - 2 Unscrew the gear lever knob.
  - 3 Remove the two screws and lift off the handbrake lever surround trim panel.
  - 4 Prise off the gear lever gaiter—4 fasteners.
  - 5 Remove the two screws and plain washers securing the front console to the transmission tunnel.

- 6 Remove the two screws and plain washers securing the consoles and bridge plate to the floor and lift off the bridge plate.
- 7 Raise the lid/armrest and remove the two screws securing the catch to the consoles. Lift off the catch and the front console.
- 8 Remove the two screws and plain washers securing the rear console to the rear parcel shelf and body—lift off the rear console.

- Refitting**
- 9 Reverse instructions 1 to 8.

**BUMPER—FRONT**

Remove and refit 76.22.08

- Removing**
- 1 Disconnect the six snap connectors from the parking and flasher lamp leads.
  - 2 Remove the outer four nuts, spring washers and plain washers.
  - 3 Support the bumper and remove the remaining two nuts, spring washers and plain washers. Lift off the bumper.

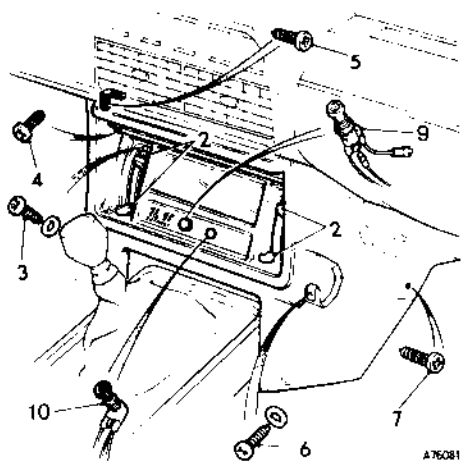

## CONTROL COWL

Remove and refit

76.25.03

### Removing

- 1 Remove the console assembly, see 76.25.01.
- 2 Pull the four knobs from the heating and ventilation control levers.
- 3 Remove the two screws securing the cowl to the control levers.
- 4 Remove the two screws securing the control illumination panel to the cowl.
- 5 Remove the screw securing the cowl to the bracket beneath the fascia.
- 6 Remove the two screws securing the cowl to the bracket on the transmission tunnel.
- 7 Remove the two screws securing the cowl to the body.
- 8 Engage top gear and pull the cowl clear of the heater.
- 9 Disconnect the bulbholder and two leads from the cigar lighter.
- 10 Disconnect the two lucar connectors from the rheostat.
- 11 Remove the cowl from the vehicle.

### Refitting

- 12 Reverse instructions 1 to 11.

## DOOR

Remove and refit

76.28.01

### Removing

- 1 Isolate the battery.
- 2 Remove the door trim pad, see 76.34.01.
- 3 Support the door and remove the six nuts, spring washers, plain washers and two adjuster plates securing it to the hinges. Lift off the door.

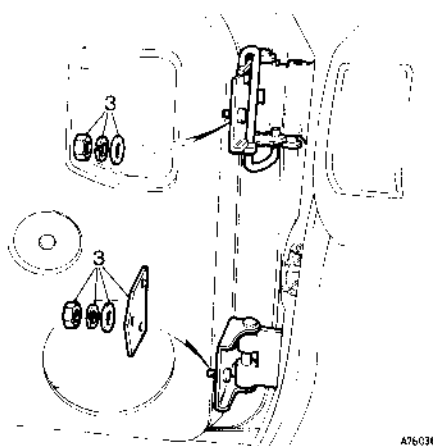

### Refitting

- 4 Reverse instructions 1 to 3. Check the door closing action and alignment and adjust if necessary before fully tightening nuts 3.

## DOOR GLASS

Remove and refit

76.31.01

### Removing

- 1 Remove the door trim pad, see 76.31.45.
- 2 Remove the door lock remote control, see 76.37.31
- 3 Remove the door glass regulator, see 76.31.45.
- 4 Remove the bolt, spring washer and plain washer securing the rear glass channel to the door. Detach the insert from the channel and carefully withdraw the channel and weather curtain.

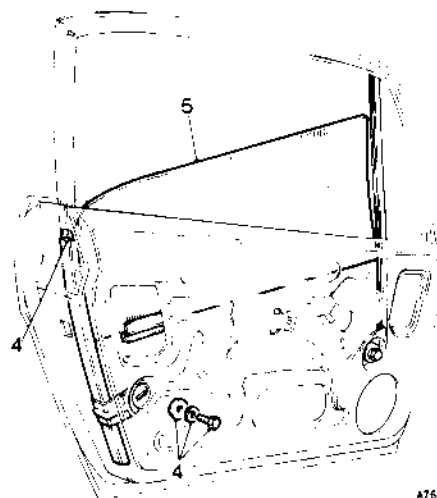

- 5 Turn the glass anti-clockwise until it can be withdrawn through the door aperture. Lift out the glass taking care to avoid scratching it on the seal clips.

### Refitting

- 6 Reverse instructions 1 to 5, ensuring that the glass channel is positioned to enable the glass to be moved freely.

## DOOR QUARTER LIGHT

Remove and refit

76.31.29

### Removing

- 1 Fully lower the door glass.
- 2 Remove the door trim pad, see 76.34.01.
- 3 Drill out the rivet securing the top of the glass channel to the door.
- 4 Remove the two bolts and plain washers securing the front glass channel to the door.
- 5 Pull the top of the glass channel away from the quarter light weatherstrip.
- 6 Carefully ease the quarter light and weatherstrip rearwards and upwards and remove them from the door.

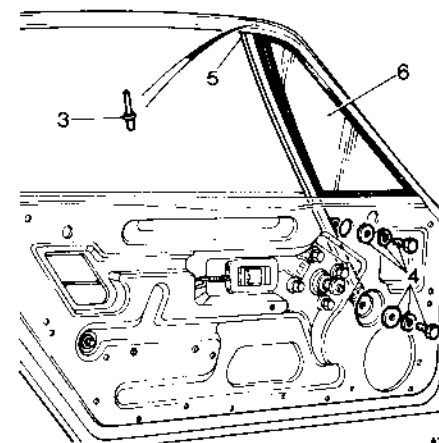

### Refitting

- 7 Reverse instructions 1 to 6, ensuring that the weatherstrips are correctly positioned.

## DOOR GLASS REGULATOR

Remove and refit

76.31.45

### Removing

- 1 Remove the door trim pad, see 76.34.01.
- 2 Remove the door lock remote control, see 76.37.31.
- 3 Refit the regulator handle, fully raise the glass and then turn the handle back (anti-clockwise) slightly to ensure that the regulator mounting bolts are not under load. Remove the handle.
- 4 Support the glass.
- 5 Remove the four bolts, spring washers and plain washers securing the regulator to the door.
- 6 Carefully push the regulator handle shaft inside the door aperture and slide the regulator assembly towards the rear of the door, lowering the glass by hand sufficiently to enable the rollers to be disengaged from the glass channels and the channel on the door interior.

*continued*

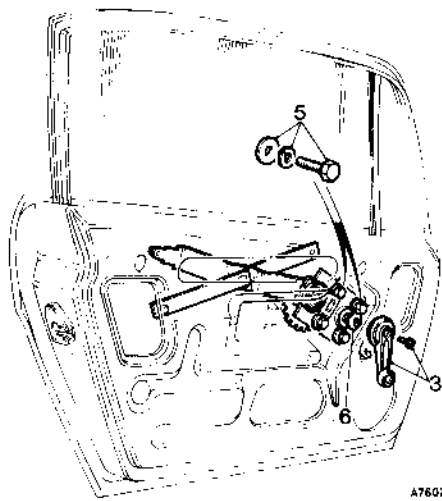

A76023

- 7 Manoeuvre the regulator out of the door through the lower aperture, taking care to avoid scratching the glass.

**Refitting**

- 8 Reverse instructions 1 to 7.

**DOOR TRIM PAD**

Remove and refit

76.34.01

**Removing**

- 1 Unscrew and remove the plunger knob.

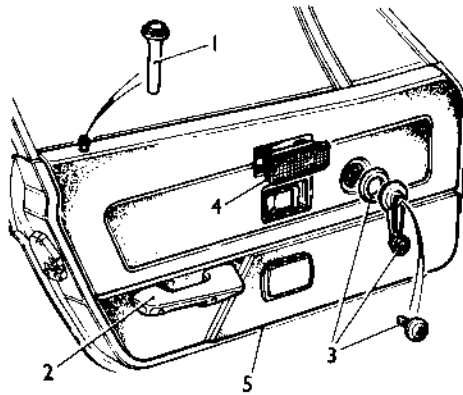

A76164

- 2 Remove the arm-rest, see 76.34.23.  
3 Remove the screw securing the regulator handle. Lift off the handle and bezel.  
4 Remove the map/courtesy lamp, see 86.45.10.  
5 Using a large screwdriver, carefully prise out the nine clips securing the trim pad to the door.  
6 Carefully lift the trim pad over the plunger rod.  
7 Disconnect the two speaker leads. — U.S.A. models.

**Refitting**

- 8 Reverse instructions 1 to 7.

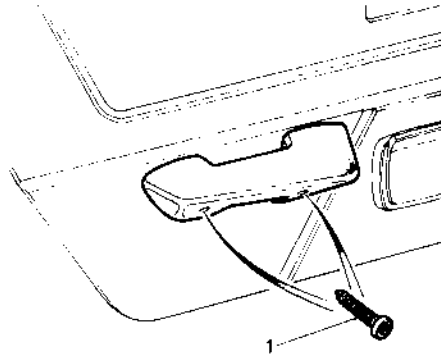

A76012

**DOOR ARM-REST**

Remove and refit

76.34.23

The door arm-rest is secured to the door shell by two screws.

**DOOR LOCK**

Remove and refit

76.37.12

**Removing**

- 1 Remove the door trim pad, see 76.34.01.  
2 Remove the bolt, spring washer and plain washer securing the rear glass channel to the door. Detach the insert from the channel and carefully withdraw the channel and weather curtain.  
3 Remove the four screws securing the lock assembly to the door and lift off the disc latch.

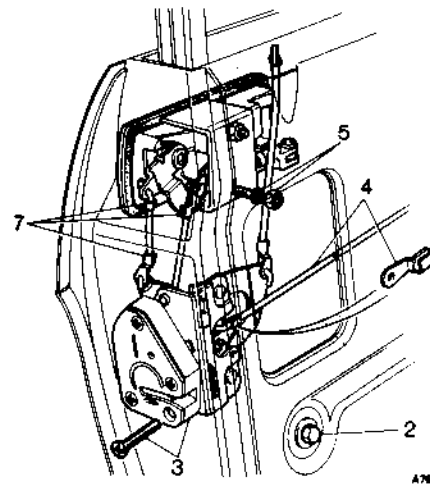

A76053

- 4 Remove the retaining clip and detach the remote control rod from the lock.  
5 Remove the two nuts and spring washers securing the clamp bracket to the outside handle.  
6 Manoeuvre the outside handle and seal, together with the door lock, through the handle aperture and out of the door.  
**CAUTION:** Care must be taken to avoid straining locks or linkages.  
7 Remove the retaining clips from the door handle and private lock control rods and separate the outside handle and door lock.

**Refitting**

- 8 Reverse instructions 1 to 7 ensuring that the plunger rod is correctly located before securing the lock to the door.

**DOOR LOCK STRIKER**

Remove and refit

76.37.23

**Removing**

- 1 Remove the rear quarter trim pad, see 76.13.12.  
2 Remove the two screws securing the striker assembly to the 'B' post.

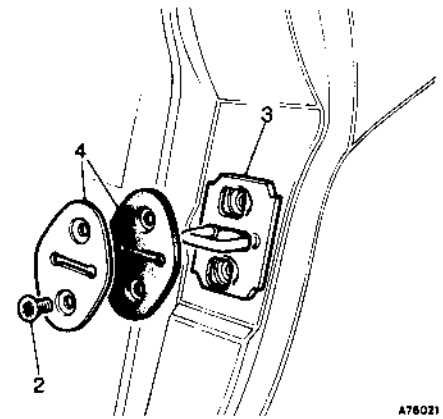

A76021

- 3 Withdraw the striker from inside the 'B' post.  
4 Lift off the outer striker plate and the seal.

**Refitting**

- 5 Reverse instructions 1 to 4.

**DOOR LOCK STRIKER**

Adjust

76.37.27

- 1 Slacken the two screws.  
2 Adjust the striker position as necessary to ensure correct door locking action and alignment.  
3 Re-tighten the screws.

**DOOR LOCK REMOTE CONTROL**

Remove and refit

76.37.31

**Removing**

- 1 Remove the door trim pad, see 76.34.01.  
2 Remove the retaining clip and detach the control rod from the lock.  
3 Remove the screw and lift off the escutcheon.  
4 Remove the screw and push the control assembly rearwards to disengage it from the door.

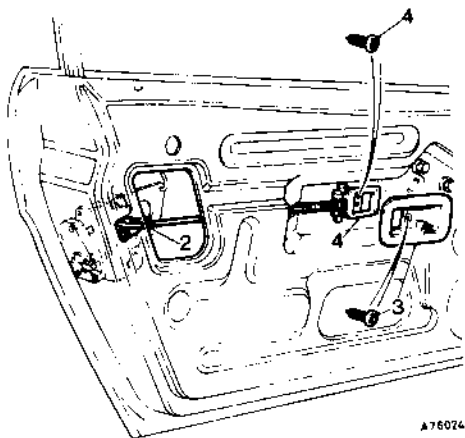

A76074

- 5 Withdraw the control assembly from the door.

**Refitting**

- 6 Reverse instructions 1 to 5.

- 3 Remove the two spring washers.  
4 Remove the locking lever.  
5 Push out the lock.

**Refitting**

- 6 Reverse instructions 1 to 5.

**WINDSCREEN FINISHER-LOWER**

Remove and refit 76.43.41

**Removing**

- 1 Remove the drivers wiper arm, see 84.15.02  
2 Remove the passengers wiper arm, see 84.15.03.  
3 Remove the nut, distance piece and rubber washer from the passenger's side wheelbox spindle.  
4 Pull off the two bulkhead weatherstrips.  
5 Remove the two screws and plain washers and detach the finisher from the body taking care to avoid scratching the body and windscreen.

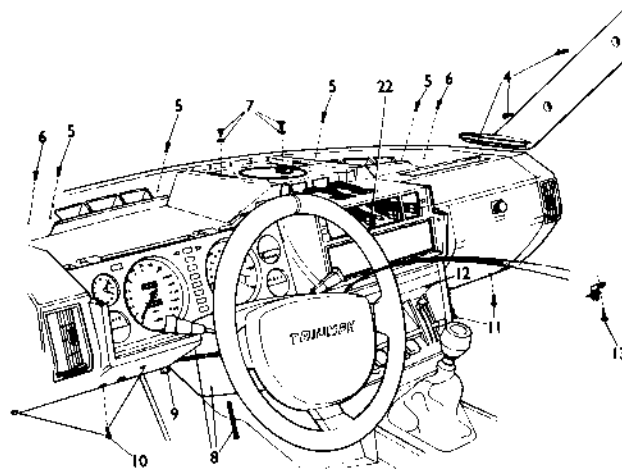
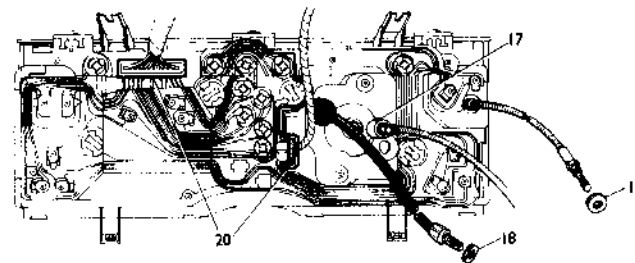

**DOOR PRIVATE LOCK**

Remove and refit 76.37.39

**Removing**

- 1 Remove the door outside handle, see 76.58.01.  
2 Remove the circlip.

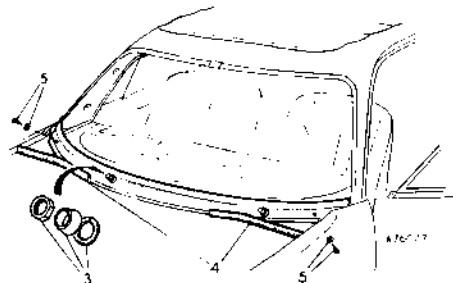

A76077

**Refitting**

- 6 Reverse instructions 1 to 5.

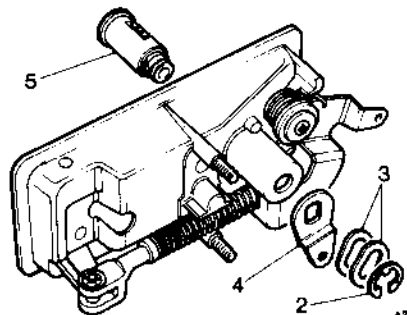

A76036

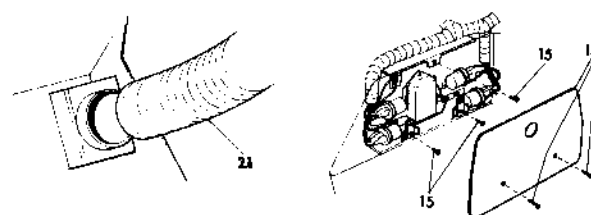

A76034

**FASCIA**

Remove and refit 76.46.01

**Removing**

- 1 Isolate the battery.  
2 Remove the instrument cowl, see 76.46.17.  
3 Remove the fascia switch panel, see 86.65.66, noting the positions of the three harness plugs and two switch identification bulb holders for refitting.

- 4 Remove the two 'A' post trim pads—two screws—together with the fascia corner finishers.  
5 Remove the four screws securing the demister vents to the fascia.  
6 Remove the two screws securing the fascia to the brackets on the bulkhead.  
7 Remove the two bolts and plain washers securing the tongues on the fascia to the bulkhead.

*continued*

- 8 Remove the steering nacelles—two screws.
- 9 Remove the two shear-head bolts securing the steering column housing to the body. Operation 57.40.01, instructions 6 and 7.
- 10 Remove the five screws (two each side of the steering column—one below bonnet release) securing the fascia to the support rail beneath the instrument panel.
- 11 Remove the two screws securing the fascia to the support rail beneath the glovebox.
- 12 Remove the two screws securing the control illumination panel to the cowl.
- 13 Remove the screw securing the fascia to the bracket on the control cowl.
- 14 Remove the lid from the component mounting panel inside the glovebox—two screws.
- 15 Remove the three screws and two brackets securing the component mounting panel to the fascia.
- 16 Remove the two screws securing the wiring harness clips to the top of the fascia.
- 17 Disconnect the cable from the speedometer by depressing the lever to release the catch from the annular groove in the boss.
- 18 Unscrew the knurled nut and release the speedometer trip reset from the bracket slot.
- 19 Unscrew the knurled nut and release the clock reset from the bracket slot.
- 20 Disconnect the two multi-contact harness plugs
- 21 Ease the fascia rearwards and pull the air hoses from the outer swivelling vents.
- 22 Carefully manoeuvre the fascia out of the car, simultaneously feeding the three harness plugs and two switch identification bulb holders through the four apertures above the switch panel aperture

**Refitting**

- 23 Ensure that the demister vents are correctly positioned.
- 24 Reverse instructions 1 to 22.

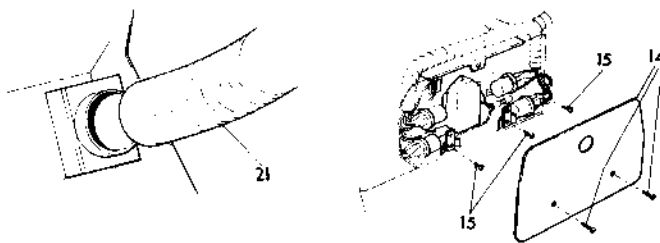
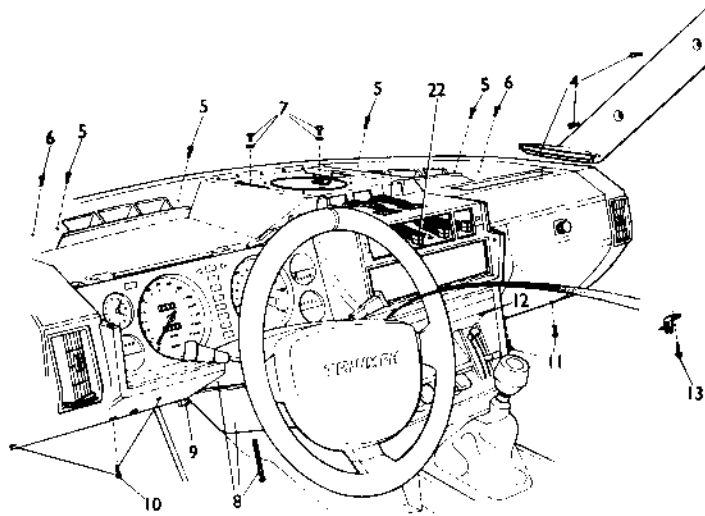
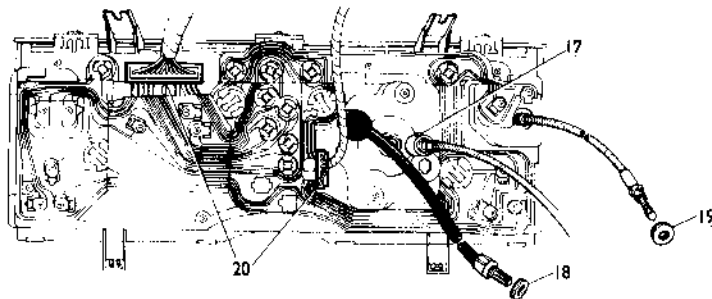
**FASCIA INSTRUMENT COWL**

Remove and refit

76.46.17

**Removing**

- 1 Remove the fascia centre grille, see 76.55.14.
- 2 Remove the two screws securing the cowl to the fascia above the switch panel.
- 3 Remove the two screws securing the cowl to the fascia above the instrument panel.
- 4 Remove the screw securing the underside of the cowl to the bracket above the switch panel.
- 5 Remove the two screws securing the outer tongues of the cowl to the fascia.
- 6 Swing the cowl rearwards to disengage the side tongues from the fascia.
- 7 Remove the cowl.

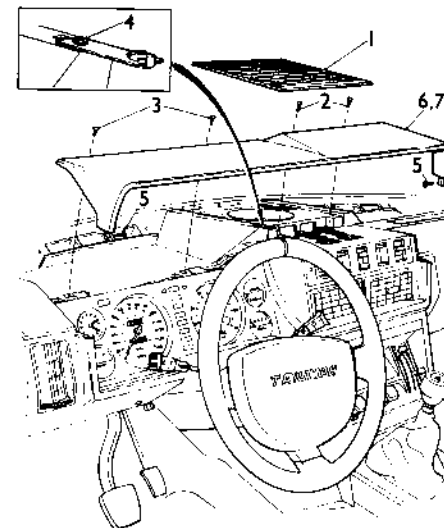

A 760 33

**Refitting**

- 8 Reverse instructions 1 to 7.

A 760 34

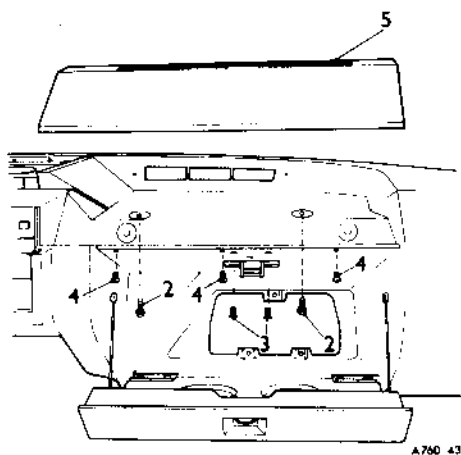

### FASCIA GLOVEBOX COWL

Remove and refit 76.46.18

#### Removing

- 1 Remove the fascia, see 76.46.01.
- 2 Remove the two bolts securing the cowl to the inside of the fascia.
- 3 Remove the three screws securing the glovebox lid latch.
- 4 Remove the three screws from inside the glovebox.
- 5 Lift off the cowl.

#### Refitting

- 6 Reverse instructions 1 to 5.

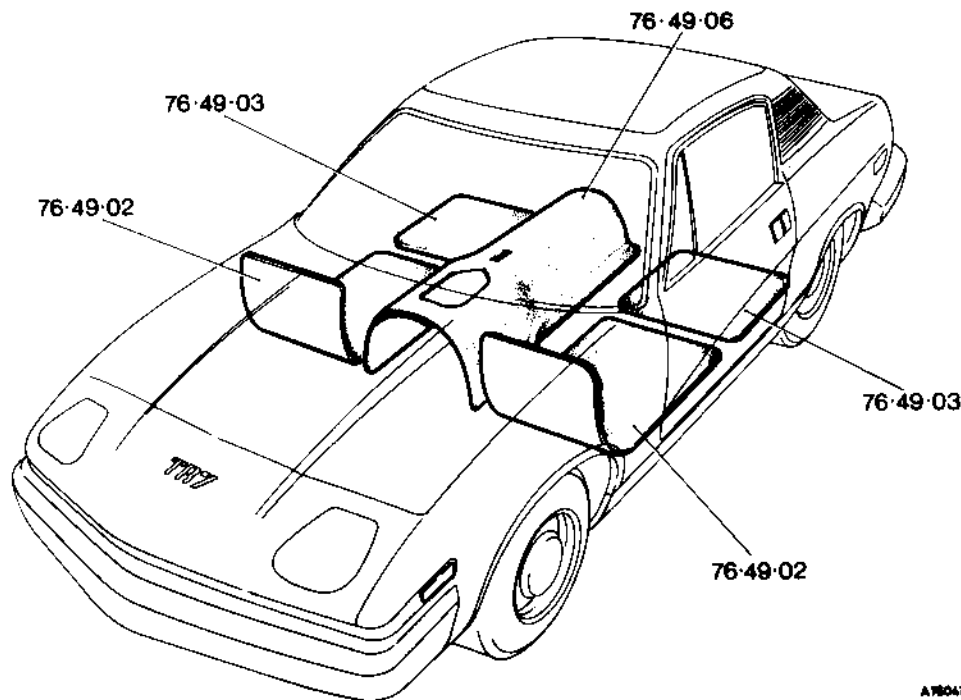

### CARPET-REAR FLOOR

Remove and refit 76.49.03

#### Removing

- 1 Remove the seat, see 76.70.04/05.
- 2 Lift out the carpet.

#### Refitting

- 3 Reverse instructions 1 and 2.

### CARPET-TRANSMISSION TUNNEL

Remove and refit 76.49.06

#### Removing

- 1 Remove the console assembly, see 76.25.01.
- 2 Lift out the carpet.

#### Refitting

- 3 Reverse instructions 1 and 2.

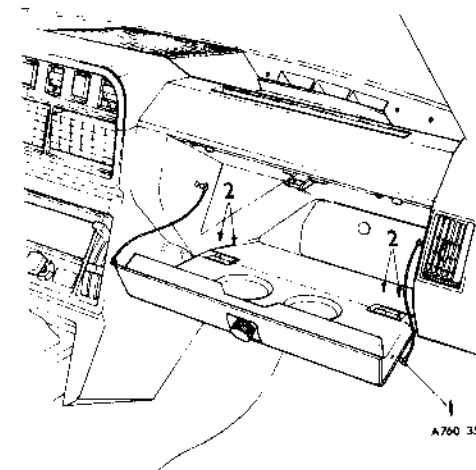

### GLOVEBOX LID ASSEMBLY

Remove and refit 76.52.02

#### Removing

- 1 Press out the centres of the rokut rivets and detach the support straps from the lid and the fascia.
- 2 Remove the four screws securing the hinges to the fascia and lift off the lid.

#### Refitting

- 3 Position the lid and refit the four hinge screws.
- 4 Fit new support straps using a suitable tool to install the rokut rivets.

**GLOVEBOX LOCK**

Remove and refit 76.52.08

**Removing**

- 1 Pull off the knob.
- 2 Remove the two bolts securing the lock to the lid interior and withdraw the lock.
- 3 Remove the latch if necessary by removing the two screws securing it to the fascia.

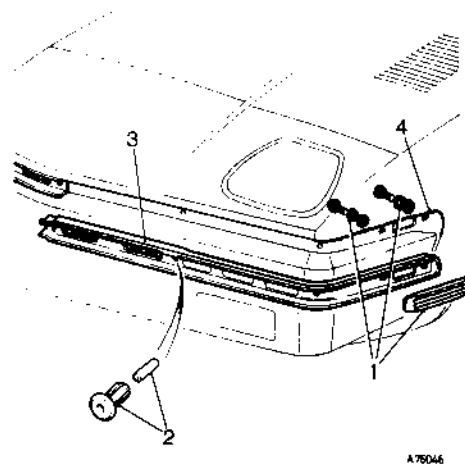
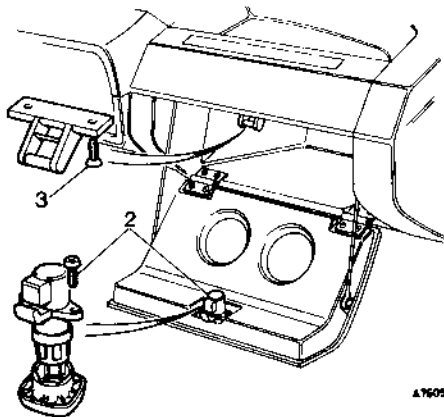
**Refitting**

- 4 Apply Seelastik to the body area shown.
- 5 Reverse instructions 1 to 3, using a suitable tool to install the rokut rivets.

**FASCIA CENTRE GRILLE**

Remove and refit 76.55.14

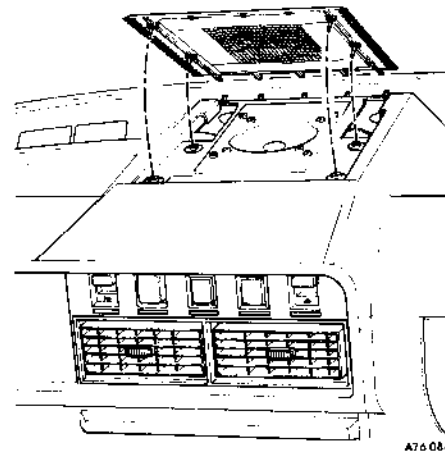
**Removing**

- 1 The grille is retained by five forward projections which locate into slots in

the fascia and by four plastic spigots which locate into 'snap backs' secured to the fascia.

- 2 Using a wide bladed screwdriver, carefully prise up the grille adjacent to the spigots.
- 3 Move the grille rearwards to disengage the forward projections.

**Refitting**

- 4 Locate the forward projections into the fascia slots.
- 5 Locate the spigots into the 'snap backs' and press down into position.

**AIR VENT GRILLE**

Remove and refit 76.55.17

**Removing**

- 1 Remove the rear quarter trim pad, see 76.13.12.
- 2 Remove the four nuts, spring washers, plain washers and two spacers. Note spacer positions for refitting—long spacer on front lower fixing—short spacer on rear lower fixing.
- 3 Lift off the moulding together with the four 'T' shaped bolts.

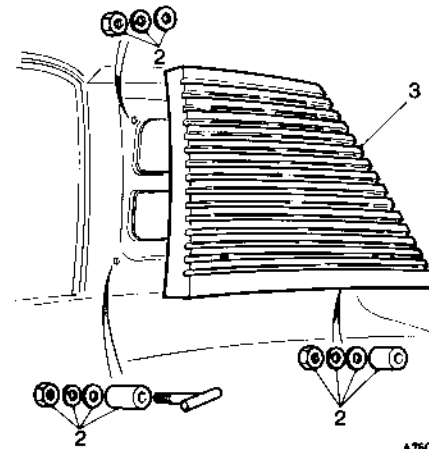
**Refitting**

- 4 Reverse instructions 1 to 3.

**DOOR OUTSIDE HANDLE**

Remove and refit 76.58.01

**Removing**

- 1 Remove the door trim pad, see 76.34.01.
- 2 Remove the bolt, spring washer and plain washer securing the rear glass channel to the door. Detach the insert from the channel and carefully withdraw the channel and weather curtain.
- 3 Remove the four screws securing the lock assembly to the door and lift off the disc latch.
- 4 Remove the retaining clip and detach the remote control rod from the lock.
- 5 Remove the two nuts and spring washers securing the clamp bracket to the outside handle.
- 6 Manoeuvre the outside handle and seal, together with the door lock, through the handle aperture and out of the door.  
**CAUTION:** Care must be taken to avoid straining locks or linkages.
- 7 Remove the retaining clips from the door handle and private lock control rods and separate the outside handle and door lock.

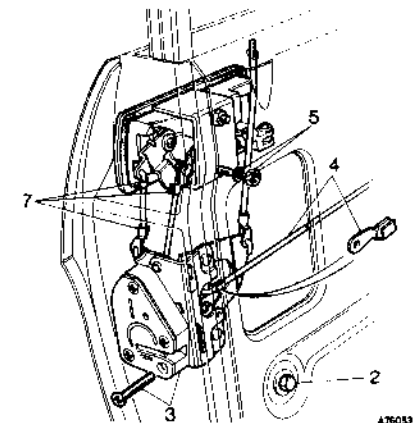
**Refitting**

- 8 Reverse instructions 1 to 7 ensuring that the plunger rod is correctly located before securing the lock to the door.

**Refitting**

- 4 Reverse instructions 1 to 3.

**FRONT GRILLE**

Remove and refit 76.55.03

**Removing**

- 1 Remove the blanking plate—two screws.
- 2 Press out the centres of the three rokut rivets securing the grille to the body.
- 3 Remove the grille.



## HOOD (USA only)

Remove and refit

76.61.08

### Removing

- 1 Release the front of the hood by turning the levers.
- 2 Disconnect the eight fasteners securing the sides of the hood to the body.
- 3 Remove the eight screws securing the rear trimboard to the body and pull the trimboard forwards.
- 4 Remove the seven nuts securing the hood retaining strip to the rear deck.
- 5 Remove the two hood linkage covers – three screws each
- 6 Lower the hood into the rearmost position ensuring that the hood material does not become damaged.
- 7 With the aid of an assistant, remove the four bolts, spring washers and plain washers and lift off the hood.

### Refitting

- 8 Install the hood and loosely fit bolts 7. Ensure that the hood moves freely, and fully tighten the bolts.
- 9 Reverse instructions 1 to 6.

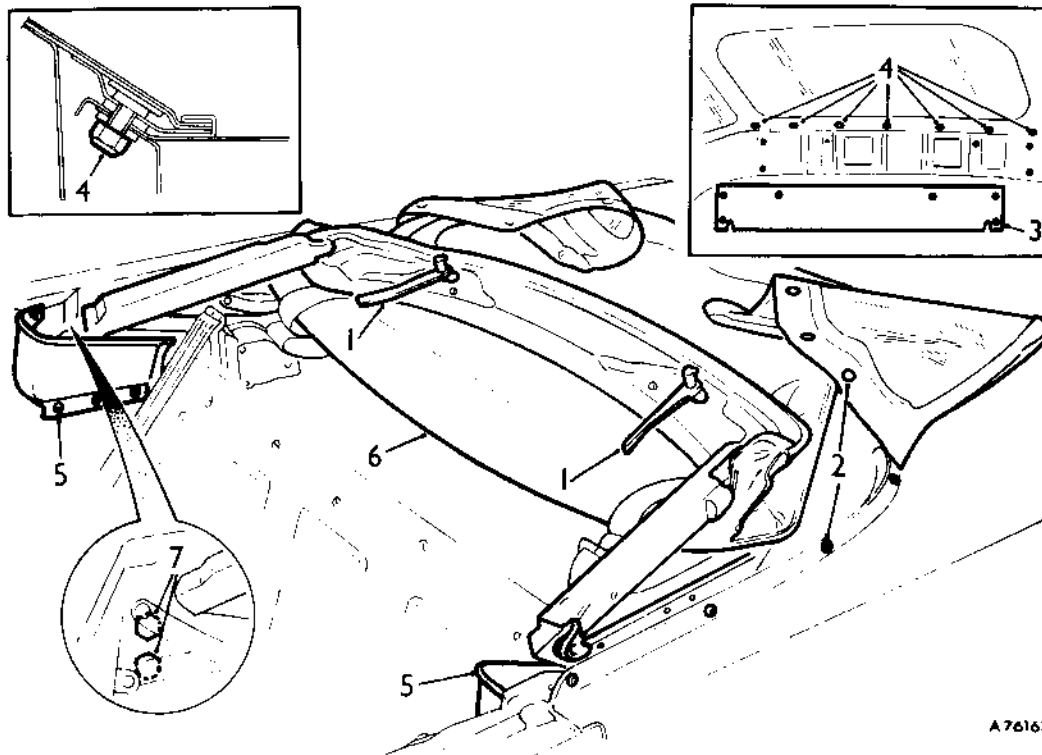

A76163

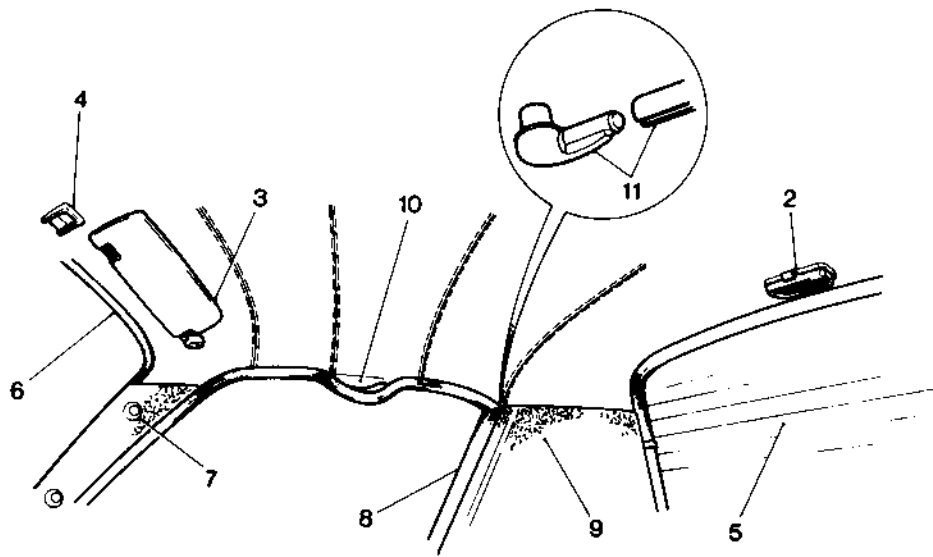

A76057

**HEADLINING**

Remove and refit  
(Cars without sliding roof) **76.64.01**

**Removing**

- 1 Isolate the battery.
- 2 Remove the roof lamp, see 86.45.02.
- 3 Remove the heated backlight, see 76.81.11.
- 4 Remove the sun visors and retainers.
- 5 Remove the interior mirror – two screws.
- 6 Pull off the windscreen header rail finisher.
- 7 Remove the two 'A' post trim pads—two screws each.
- 8 Pull off the door weatherstrips.

- 9 Remove the rear quarter trim pads, see 76.13.12.
- 10 Pull the lining edges away from the body flanges.
- 11 Detach the listing rails and remove the headlining.

**Refitting**

- 12 Apply a 2 in border of Dunlop SP 758 adhesive to the headlining, around the roof light aperture, and on the body flanges. Allow ten minutes for the adhesive to become tacky.
- 13 Reverse instructions 1 to 11, cutting off any excess material, to leave approximately 13 mm (½ in) overlap on all flanges and apertures.

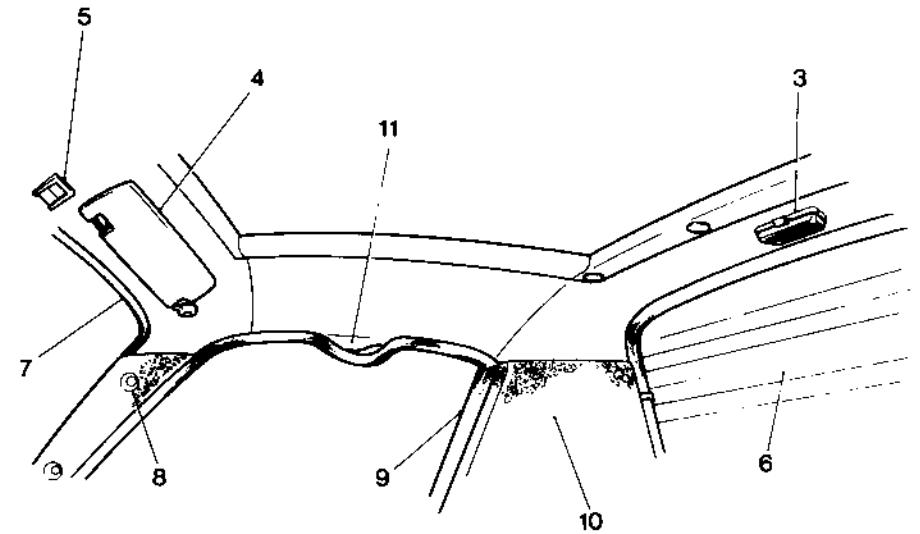

A76042

**HEADLINING**

Remove and refit  
(Cars with sliding roof) **76.64.01**

**Removing**

- 1 Isolate the battery.
- 2 Remove the sliding roof, see 76.82.01.
- 3 Remove the roof lamp, see 86.45.02.
- 4 Remove the heated backlight, see 76.81.11.
- 5 Remove the sun visors and retainers.
- 6 Remove the interior mirror – two screws.
- 7 Pull off the windscreen header rail finisher.
- 8 Remove the two 'A' post trim pads – two screws each.

- 9 Pull off the door weatherstrips.
- 10 Remove the rear quarter trim pads, see 76.13.12.
- 11 Pull the lining edges away from the body and remove the headlining from the vehicle.

**Refitting**

- 12 Apply a 2 in border of Dunlop SP 758 adhesive to the headlining edges and around the roof light and sliding roof apertures. Allow ten minutes for the adhesive to become tacky.
- 13 Reverse instructions 1 to 11, cutting off any excess material to leave approximately 13 mm (½ in) overlap on all flanges and apertures.

## PARCEL TRAY-REAR

Remove and refit

76.67.06

### Removing

- 1 Move both seats and seat squabs to the fully forward position.
- 2 Remove the two bolts and spring washers securing the seat belt swivel brackets to the seats.
- 3 Feed the seat belts through the apertures in the parcel tray.
- 4 Remove the four screws and cup washers securing the parcel tray and rear compartment trim pad to the body.
- 5 Remove the four screws and cup washers securing the rear of the parcel tray to the body.
- 6 Carefully manoeuvre the parcel tray upwards and forwards and remove it from the car.

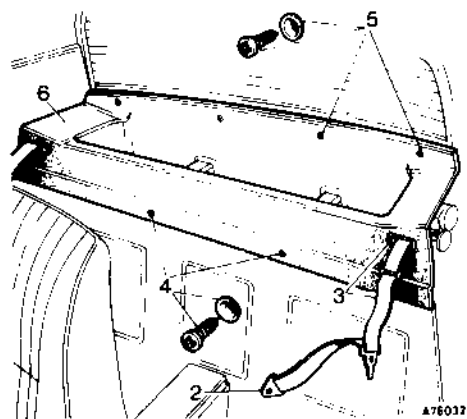

### Refitting

- 7 Install the parcel tray in the car, feeding both seat belts through the apertures before finally positioning it.
- 8 Reverse instructions 1, 2, and 4 to 6.

## ASHTRAY

Remove and refit

76.67.13

### Removing

- 1 Depress the stubber to release the top edge of the bowl and carefully disengage the retainers on the bottom edge from the surround.
- 2 Using a small screwdriver carefully prise up the retainers on the surround sufficiently to enable it to be pulled clear of the trim pad.

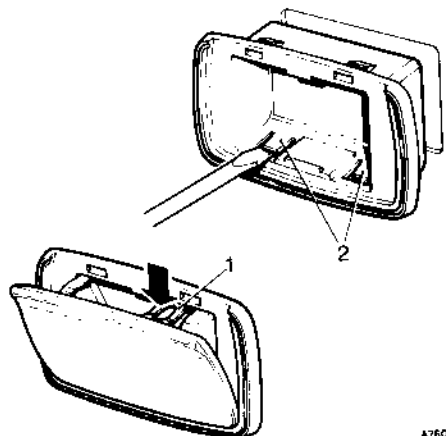

A76013

### Refitting

- 3 Press the surround into the trim pad sufficiently to engage the retainers.
- 4 Refit the bowl.

## SEATS

Remove and refit

Driver's seat

76.70.04

Passenger's seat

76.70.05

### Removing

- 1 Move the seat fully rearwards.
- 2 Remove the two capscrews (long), and rectangular washers securing the runners to the floor.

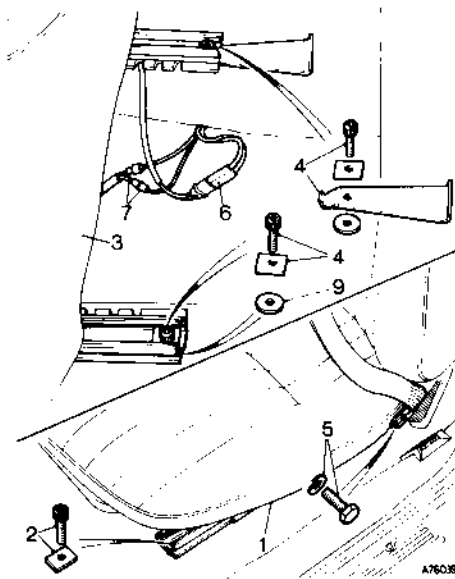

A76018

- 3 Move the seat fully forwards.
- 4 Remove the two capscrews (short), one rectangular washer and one stop plate securing the seat to the floor.
- 5 Remove the bolt and spring washer securing the seat belt bracket to the seat.

- 6 Disconnect the seat belt buckle unit harness plug (if fitted).
- 7 Disconnect the two seat belt warning light switch harness plugs (if fitted).
- 8 Lift out the seat complete with runners.

### Refitting

- 9 Ensure that the packing washers are correctly positioned.
- 10 Reverse instructions 1 to 8.

## SEAT RUNNERS

Remove and refit

76.70.21

### Removing

- 1 Remove the seat, see 76.70.04/76.70.05.
- 2 Remove the six capscrews and spring washers securing the runners to the seat, moving the slides as necessary to obtain access.

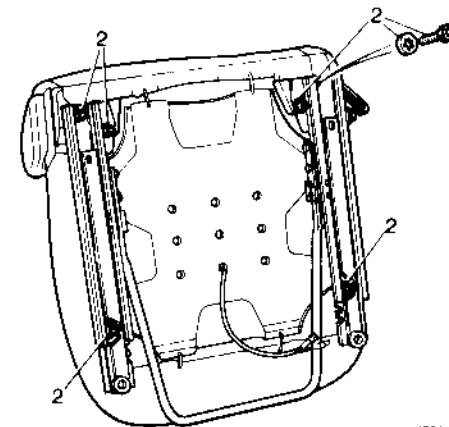

A76040

### Refitting

- 3 Reverse instructions 1 and 2.

**SEAT BELTS**

Remove and refit

76.73.10

**Removing**

- 1 Remove the bolt and spring washer securing the swivel bracket to the seat.
- 2 Feed the seat belt through the aperture in the parcel shelf.
- 3 Working inside the luggage compartment remove the trim panel above the wheel arch—two fasteners.
- 4 Remove the bolt and spring washer securing the reel unit mounting bracket to the wheel arch.

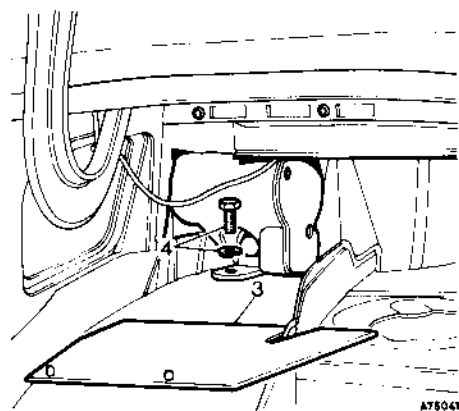
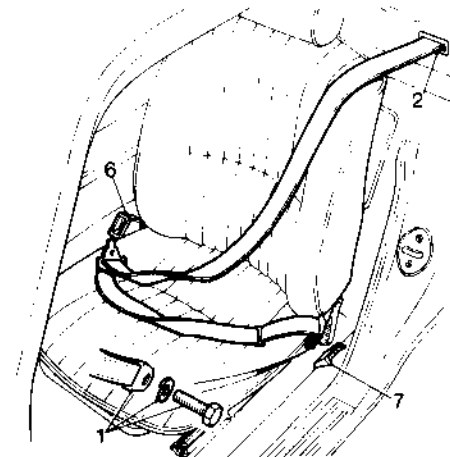

- 5 Withdraw the seat belt and reel from the vehicle.
- 6 Remove the seat belt switch if necessary, see 86.65.31/86.65.32.
- 7 Remove the tongue retainer, if necessary—two screws.

**Refitting**

- 8 Reverse instructions 1 to 7.

**WINDSCREEN**

Introduction

76.81.00

The Thermo Electric Windscreen Sealer is an uncured 'Neoprene' based material supplied in round strip form, which has a thin insulated resistance wire running through its centre core. The compound surrounding the wire also has a heat activated accelerator incorporated in it and has sufficient initial tackiness to adhere it to the painted metal aperture.

The service kit contains a preformed Solbit sealing strip of sufficient length to lap completely around the windscreen aperture flange. Also included are a bottle of primer, wire for cutting out laminated windcreens and two rubber spacers for supporting the new windscreen. The internal resistance wire is exposed at each end of the strip and connected to a low voltage electrical supply. This is obtained by connecting two fully charged 12 volt batteries in series (+ to -) or alternatively using a variable output transformer capable of giving 11 amps at 24 volts. A lower current would be insufficient to effect a satisfactory cure of the Solbit strip. The resistance wire becomes warm and softens the strip, enabling the windscreen and finishers to be bedded into position. Further heat helps to cure the sealer and after 1½ to 2 hours the adhesion is strong enough for the car to be used.

**NOTE:**

- A The aid of an assistant is required for this operation.  
 B Glass lifters should be used for handling the screen.  
 C Cleanliness is essential.

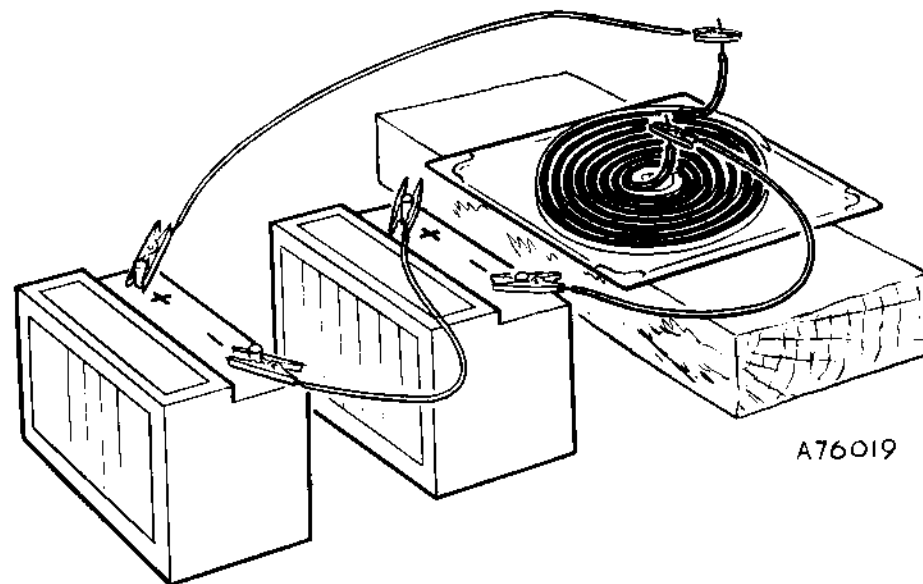

A76019

**WINDSCREEN**

Remove and refit

76.81.01

**Removing**

- 1 Cover the fascia and interior trim to protect them from broken glass.
- 2 Remove the windscreen wiper arms, see 84.15.02/03.
- 3 Remove the lower windscreen finisher, see 76.43.41.
- 4 Remove the 'A' post trim pads—two screws, together with the fascia corner finishers.
- 5 Pull off the header rail finisher.
- 6 Push the finisher moulding cover to one side to expose the Solbit.

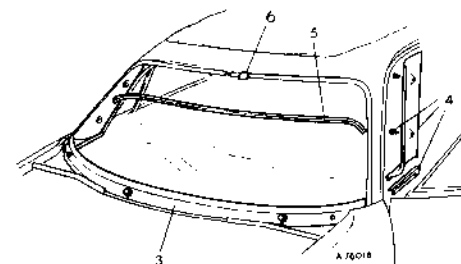

A 76018

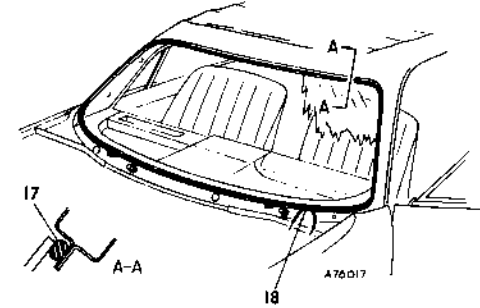
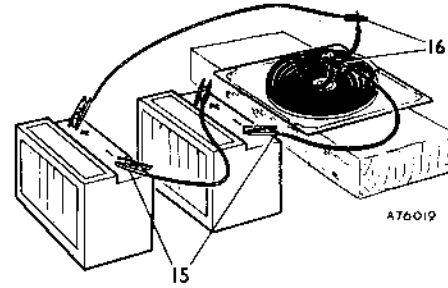
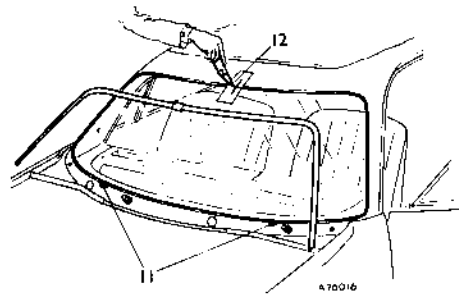
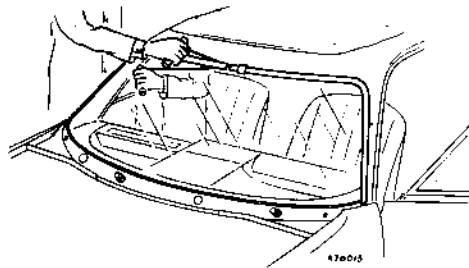

- 7 From both outside and inside, cut or pierce a hole through the existing Solbit and thread one end of the wire through the hole to an assistant inside the car. At each end of the wire twist on a small piece of wood to act as a handle or form a handle by threading the wire through a small hole drilled in the end of an old screwdriver. By pulling the wire in a saw like motion, cut through the Solbit. Use long steady pulls rather than short quick ones otherwise the wire will overheat and break. Narrow the angle of the cut by keeping the wire ends as close as possible to the glass. Ensure that the wire outside the car is pulled along the moulding rather than the painted body otherwise the latter will be damaged.
- 8 With a sharp knife, cut through the old Solbit remaining on the flange and remove it by a combination of cutting and pulling.
- 9 Cut away any sharp edges or remaining lumps of old Solbit to ensure an even surface.
- 10 Cut away and remove Solbit from the finisher mouldings. Avoid distorting the mouldings during the cleaning operation. It may be necessary to obtain replacements. Remove any dirt or loose material from the flange using a clean lint-free cloth moistened with methylated spirit.

### Refitting

- 11 Place the two rubber spacers from the kit on to the bottom flange about 150 mm (6 in) to 225 mm (9 in) from the pillars. Using glass lifters, offer the windscreen up to rest on the spacers; positioning it to give equal gaps all the way round. Position finisher mouldings and join them together at the top with the cover to ensure that they fit well and have not been distorted during removal. Remove the finisher mouldings.  
**NOTE:** If any straightening of the mouldings is necessary, it should be carried out at this stage.
- 12 Place a piece of masking tape approximately on the top centre of the glass, sticking this across the gap between the glass and the body. Mark the masking tape so as to facilitate location when finally placing the windscreen for fitting. Then cut through the tape between the glass and body and remove the windscreen on to a bench.  
**NOTE:** Take careful note of the size of the gap because when applying the Solbit strip to the flange, there must be sufficient Solbit along the whole length of the gap into which the reveal mouldings are embedded and sufficient Solbit under the glass for a watertight bond line to be made.

- 13 Apply a thin coat of primer to the remaining Solbit or painted flange using a clean lint-free cloth. Allow to dry for approximately one minute.
- 14 Clean the new windscreen with a solvent (e.g. methylated spirit) if necessary, and apply a thin coating of primer, no more than 13 mm (½ in) wide, to the periphery of the inner face of the windscreen. Allow to dry for approximately one minute.
- 15 Connect two fully charged 12 volt batteries in series (+ to -).  
**NOTE:** Alternatively a variable output transformer set to give 11 amps at 24 volts may be used.
- 16 Expose the bared ends of the wire in the Solbit strip whilst in the container pack and connect to the batteries or transformer until the Solbit is just sufficiently tacky to adhere to the flange. This time can vary between 15 and 90 seconds depending on the temperature and age of the Solbit. Disconnect the current.  
**NOTE:** Do not overheat the Solbit as this will make it both difficult to remove from the pack and to handle.
- 17 Starting about 75 mm (3 in) from one of the bottom corners of the screen aperture, place the Solbit strip on the flange so that when the windscreen is fitted, there is sufficient exudation of Solbit to the right and the left of the edges of the screen aperture for bonding the glass and for embedding the chrome finishers.

- 18 Cross over the ends of the Solbit, approximately 50 mm (2 in) in length at the lower right corner of the windscreen aperture, having first placed a small strip of masking tape on the body to prevent marking by the ends of the Solbit.  
**NOTE:** Care must be taken with this operation otherwise a hairline crack could be left on the surface of the Solbit after compression.
- 19 Using glass lifters install the windscreen in the aperture resting the bottom edge on the spacers and taking care to position it exactly where previously marked with the masking tape. Avoid fingering the primed areas. Remove approximately 25 mm (1 in) of the exposed excess Solbit from the wire.
- 20 Connect the two bared wire ends of the Solbit strip to the 24 volt supply. This will begin to soften the Solbit and after 1½ to 2 minutes, press the glass into the Solbit, starting with pressure in the centre of the glass and out to the pillars. Do not press the glass too far into the Solbit at this stage because, if somewhat proud, the depth can be rectified when the chrome finishers are embedded into the Solbit.

*continued*

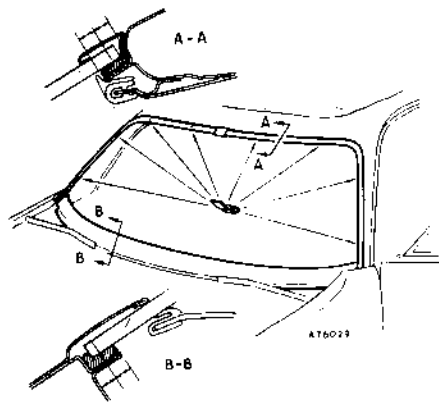
**HEATED BACKLIGHT**

Remove and refit

76.81.11

**Removing**

- 1 Break the seal, using a suitably blunt tool.
- 2 Carefully pull the rear edges of the rear quarter trim pads away from the body to expose the Lucar connectors. Disconnect the two Lucar connectors from the backlight.
- 3 Push the glass outwards.  
**CAUTION:** Take care to avoid scratching the glass, which must be steadied by an assistant.
- 4 Remove the weatherstrip from the glass.

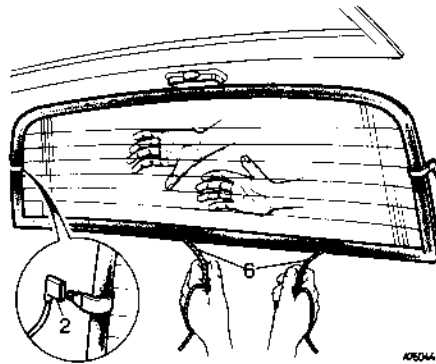
**Refitting**

- 5 Reverse instruction 4 using a new weatherstrip if necessary, and apply Seelastik to the glass channel before fitting.
- 6 Insert a strong cord into the weatherstrip inner channel, allowing the ends to protrude from the lower edge.
- 7 Have an assistant position the glass centrally in the aperture, and maintain a steady pressure whilst the cord ends are pulled to locate the weatherstrip on the body flange.
- 8 Seal the outer channel of the weatherstrip to the body using Seelastik.
- 9 Reconnect the two Lucar connectors and ensure that the rear quarter trim pads are correctly positioned.

- 21 Inspect the bond line (which should be no less than 7 mm (¼ in) wide) through the glass during early stages of the heating cycle. Potential leak sources can easily be seen and rectified by a little extra pressure in the area while the heat is on or by pressing some of the previously removed excess Solbit into the particular leak source.
- 22 After 10 minutes position and embed the chrome finishers into the Solbit; very little pressure is required. If at this stage mouldings and windscreen are proud, additional pressure can be applied. Disconnect electrical current after 1½ to 2 hours.
- 23 Allow the glass to cool down.
- 24 Test for water leaks.
- 25 Trim off exposed ends of Solbit and rubber spacers with snips or press out of sight into the rebate.
- 26 Refit the header rail.
- 27 Refit the 'A' post trim pads—2 screws, together with the fascia corner finishers.
- 28 Refit the lower windscreen finisher, see 76.43.41.
- 29 Refit the windscreen wiper arms, see 84.15.02/03.

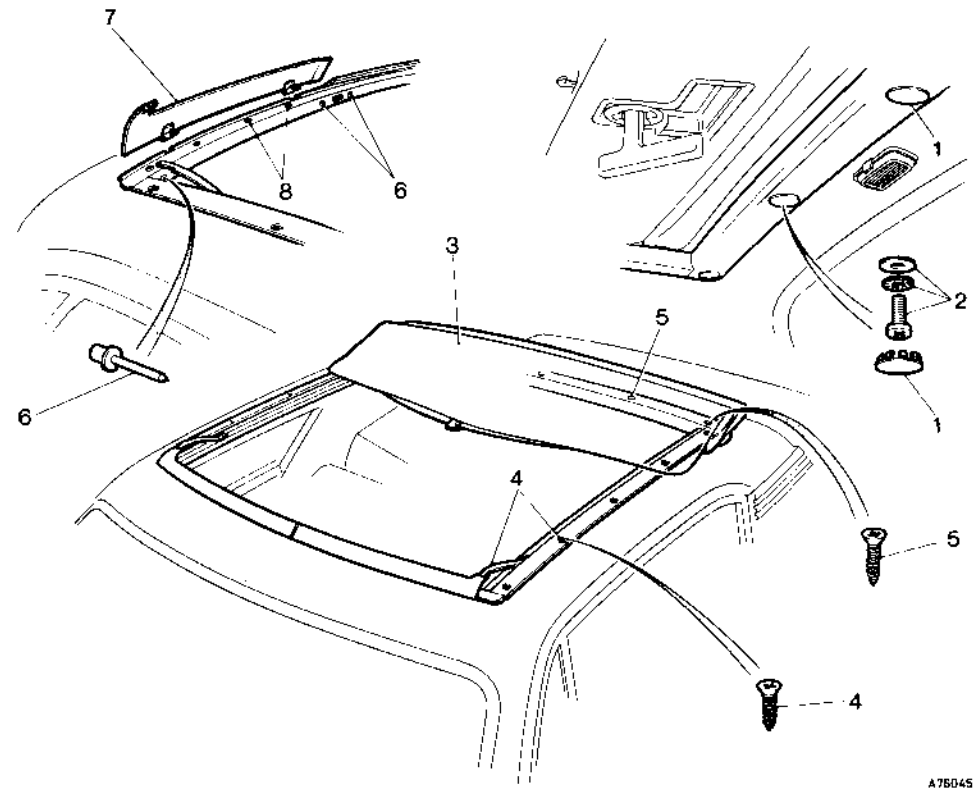
**SLIDING ROOF**

Remove and refit

76.82.01

**Removing**

- 1 Prise out the four chrome caps.
- 2 Remove the four screws, spring washers and plain washers.
- 3 Open the roof and carefully pull it rearwards on one side at a time until the four slides are disengaged from the runners. Lift off the roof.
- 4 Remove the five screws securing one of the side runners to the roof. Remove the runner taking care to avoid breaking the spring when disengaging it. Remove the opposite side runner in the same manner.
- 5 Remove the five screws securing the rear frame to the roof. Remove the frame.

- 6 Drill out the four rivets on the vertical face of the front frame.
- 7 Carefully pull the two hinge brackets outwards to disengage them.
- 8 Drill out the eight rivets on the top face of the frame. Remove the frame.

**Refitting**

- 9 Ensure that the headlining is correctly positioned with an overlap of approximately 13 mm (½ in).
- 10 Apply Kelseal to the forward top face of the roof aperture.
- 11 Reverse instructions 3 to 8.
- 12 Close the roof and adjust if necessary to obtain correct tension before fully tightening screws 2.
- 13 Replace the four chrome caps.

## DEMISTER DUCTS

Remove and refit – L.H. 80.15.03  
– R.H. 80.15.08

### Removing

- 1 Remove the fascia, see 76.46.01.
- 2 Detach the duct from the heater unit.

### Refitting

- 3 Fit new spring nuts to the ducts.
- 4 Reverse instructions 1 and 2.

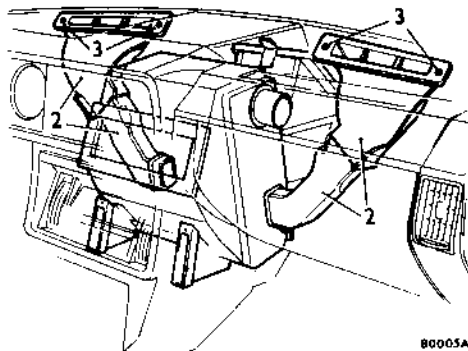

## AIR HOSES

Remove and refit – R.H. 80.15.11  
– L.H. 80.15.12

### Removing

- 1 Remove the fascia, see 76.46.01.
- 2 Pull the hose ends from the heater.

### Refitting

- 3 Reverse instructions 1 and 2.

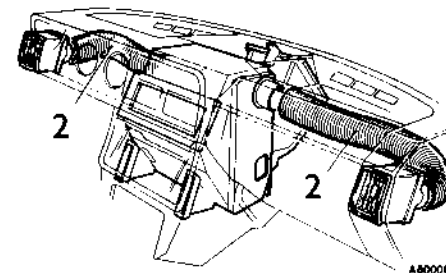

## SWIVELLING VENTS – OUTER

Remove and refit – R.H. 80.15.23  
– L.H. 80.15.22

### Removing

- 1 Remove the fascia, see 76.46.01.
- 2 Push the vent assembly outwards to release the four tongues securing the vent to the fascia.
- 3 Depress the sides of the vent sufficiently to release the four tongues securing it to the duct.
- 4 Remove the duct and pull out the vent.

### Refitting

- 5 Reverse instructions 1 to 4.

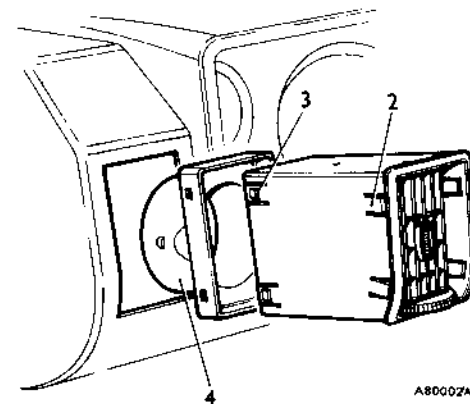

**SWIVELLING VENT – CENTRE**

– Remove and refit 80.15.24

**Removing**

- 1 Depress one side of the vent frame to detach the retaining boss from the surround.
- 2 Lift out the vent.

**Refitting**

- 3 Reverse instructions 1 and 2.

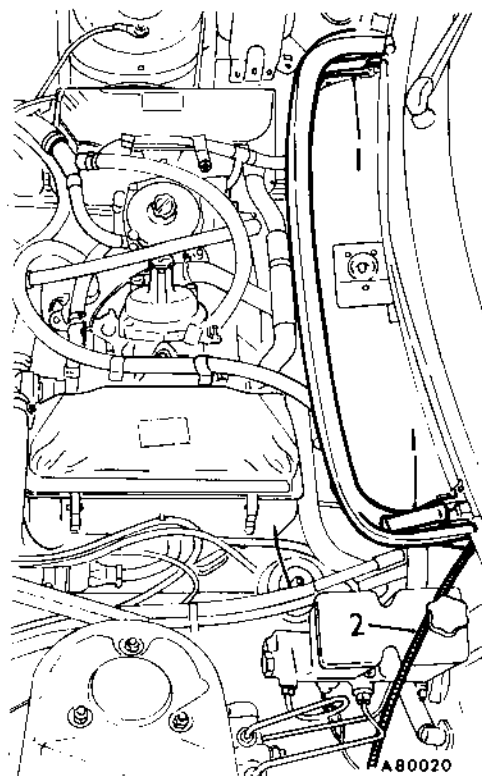
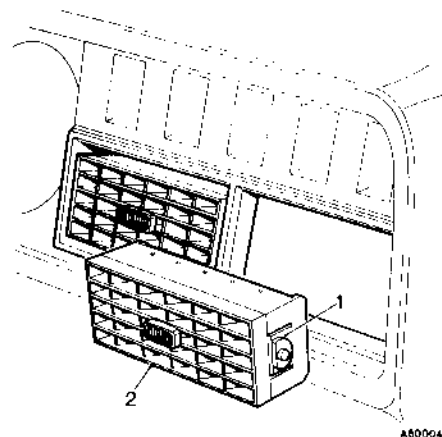
**FRESH AIR DUCT**

Remove and refit 80.15.31

**Removing**

- 1 Release the two clips.
- 2 Disengage the bonnet lock cable from the duct and carefully manoeuvre the duct clear of the engine compartment.

**Refitting**

- 3 Reverse instructions 1 and 2 ensuring that the duct is located in the retaining clips on the bulkhead.

**HEATER UNIT**

Remove and refit 80.20.01

**Removing**

- 1 Isolate the battery.
- 2 Drain the coolant.
- 3 Remove the fresh air duct, 80.15.31.
- 4 Slacken the two clips and disconnect both water hoses from the heater.
- 5 Remove the fascia, 76.46.01.
- 6 Remove the two air hoses from the heater.

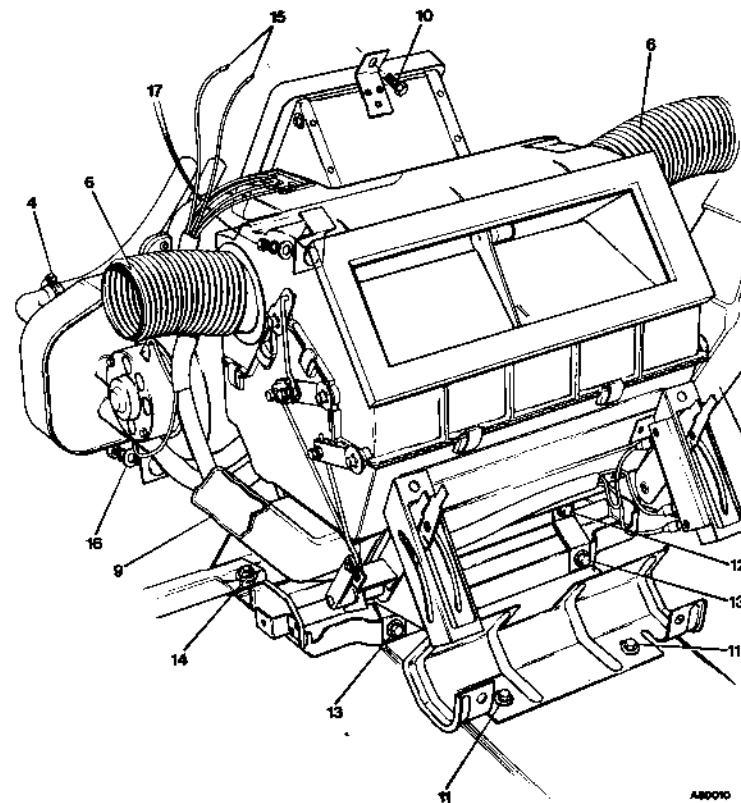

- 7 Remove the console assembly, 76.25.01.
- 8 Remove the control cowl, 76.25.03.
- 9 Remove the two demister ducts from the heater unit.
- 10 Remove the one bolt securing the heater air intake to the bulkhead.
- 11 Remove the control cowl support bracket – two bolts, spring washers and plain washers.
- 12 Slacken the two bolts securing the heater to the front of the heater support bracket on the transmission tunnel.
- 13 Remove the two heater support brackets – two bolts, spring washers, and plain washers.

- 14 Remove the two nuts, bolts, spring washers and plain washers securing the fascia support rails to the support bracket on the transmission tunnel.
- 15 Disconnect the two leads from the fan motor. (1 Black 1 Green).
- 16 Remove the nut, spring washer and plain washer securing the water pipe bracket to the bulkhead.
- 17 Remove the nut, spring washer and plain washer securing the rear of the heater to the bulkhead.
- 18 Remove the heater from the vehicle taking care to avoid spillage of coolant remaining in the matrix.

**Refitting**

- 19 Reverse instructions 1 to 18.

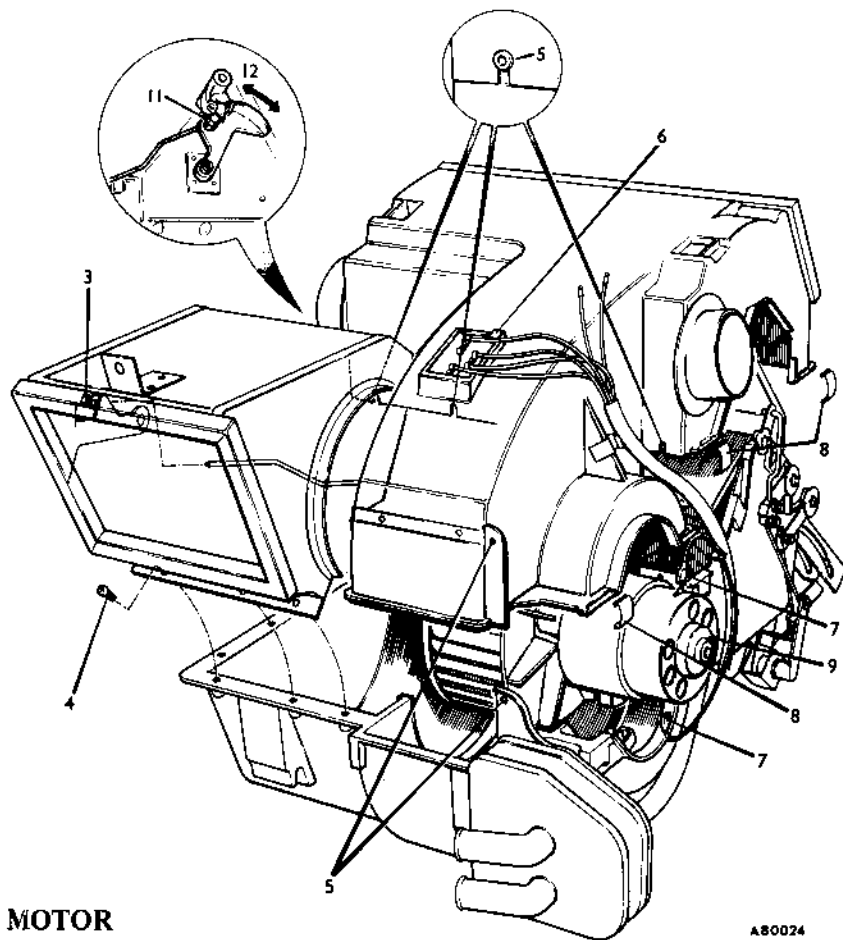

**FAN MOTOR**

Remove and refit

80.20.15

**Removing**

- 1 Isolate the battery.
- 2 Remove the heater, see 80.20.01.
- 3 Slacken the trunnion and disconnect the air intake control rod.
- 4 Remove the six screws and detach the air intake from the heater.
- 5 Drill out the four rivets.
- 6 Release the clip and detach the resistor from the heater.
- 7 Disconnect the two Lucar connectors from the fan motor.
- 8 Detach the fourteen clips and lift off the upper half of the casing.

- 9 Lift out the fan motor.

**Refitting**

- 10 Reverse instructions 9 to 4.
- 11 With the cam set in the position shown, set the air inlet flap against the aperture with the control lever in the 'OFF' position and tighten the trunnion screw.
- 12 Operate the control lever to check engagement of detents and full movement of the flap, then return the lever to the 'OFF' position and check sealing of the flap.
- 13 Reverse instructions 1 and 2.

**HEATER MATRIX**

Remove and refit

80.20.29

**Removing**

- 1 Isolate the battery.
- 2 Remove the heater unit, see 80.20.01.
- 3 Remove the fan motor, see 80.20.15.
- 4 Remove the seal from the pipe flange plate.
- 5 Drill out the rivet securing the pipe flange plate to the heater.
- 6 Remove the two screws securing the pipe mounting bracket to the heater. Lift off the bracket and packing piece.
- 7 Carefully ease the pipe assembly out of the matrix bushes.
- 8 Slacken the three trunnions and disconnect the flap operating rods from the levers.

- 9 Lift off the face level flap.
- 10 Lift off the heater inlet flap.
- 11 Drill out the four rivets securing the control level mounting plate to the heater.
- 12 Remove the two screws securing the lower flange of the control lever mounting plate to the heater. Lift off the mounting plate.
- 13 Remove the spire nut securing the lower side flap operating rod to the lever and disconnect the rod from the lever.
- 14 Remove the spire nut securing the lower flap spindle to the matrix housing.
- 15 Carefully pull the operating lever and spring clip off the lower flap spindle.
- 16 Detach the lower flap from the matrix housing and collect the spacer.

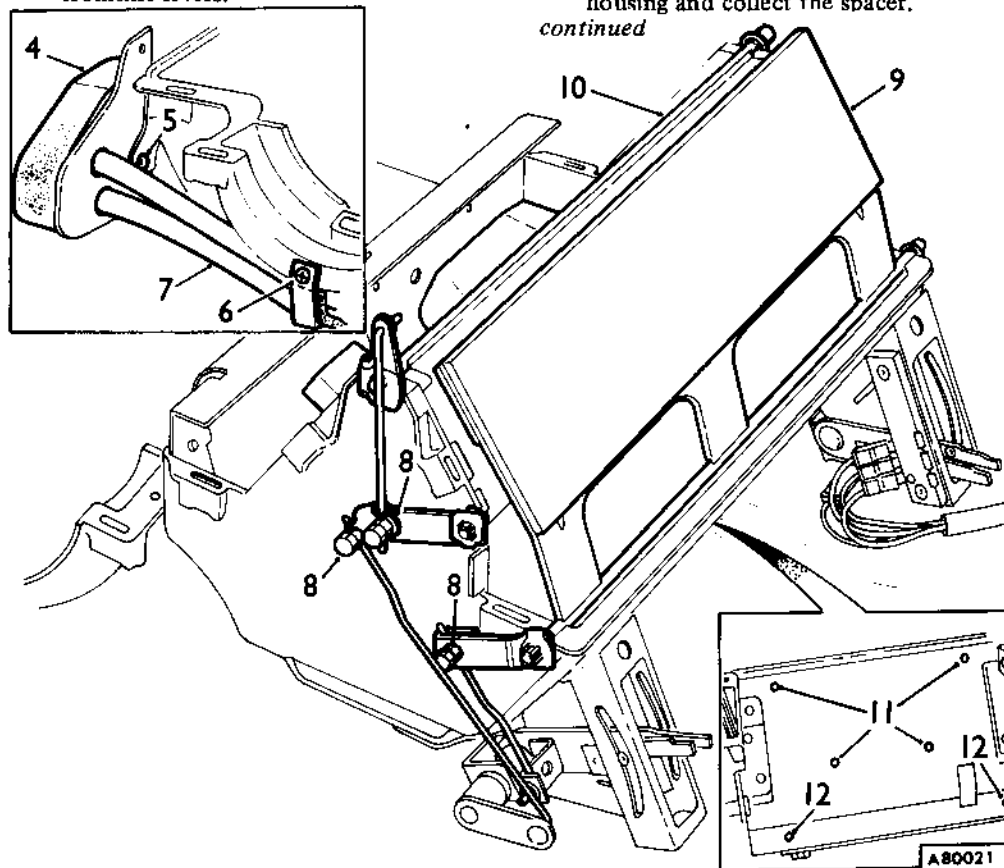
*continued*

A80021

- 17 Drill out the two rivets securing the lower side flap assembly to the heater box.
- 18 Remove the lower side flap assembly.
- 19 Drill out the seven rivets securing the matrix housing to the heater box.
- 20 Remove the matrix complete with housing from the heater box.
- 21 Remove the matrix from the housing.

**Refitting**

- 22 Fit two new pipe seals into the matrix and replace the foam packing piece.
- 23 Reverse instructions 8 to 21.
- 24 Lubricate the pipes and seals with an anti-freeze solution.
- 25 Reverse instructions 7 to 3.
- 26 With the face level ventilation flap closed against the aperture as shown and the control lever in the 'OFF'

- position, tighten the trunnion screw.
- 27 Operate the control lever to check engagement of detents and full movement of the flap, then return the lever to the 'OFF' position and check sealing of the flap.
- 28 With the lower flap closed against the aperture as shown and the control lever in the 'SCREEN' position tighten the trunnion screw.
- 29 Operate the control lever to check engagement of detents and full movement of the flap, then return the lever to the 'SCREEN' position, and check sealing of the flap.
- 30 With the cam in the position shown set the air inlet flap against the aperture with the control lever in the 'OFF' position and tighten the trunnion screw.

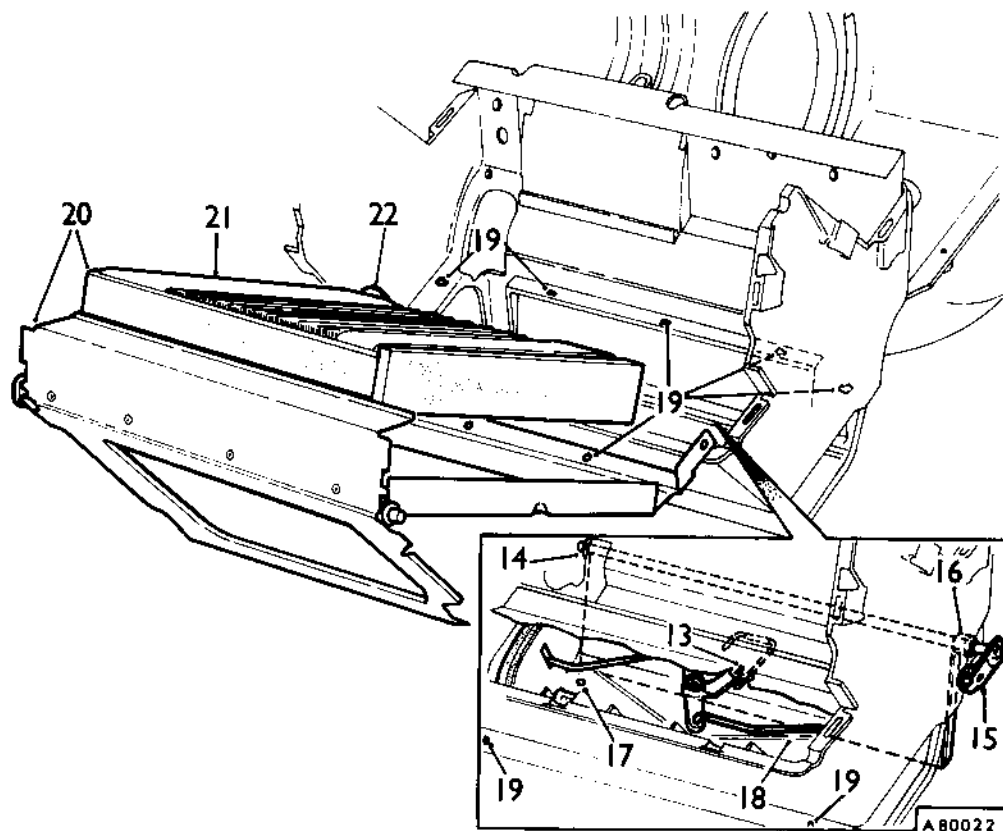

A80022

- 31 Operate the control lever to check engagement of detents and full movement of the flap, then return the lever to the 'OFF' position and check sealing of the flap.
- 32 With the heater inlet flap set as shown and the outlet flap closed as shown, tighten the trunnion screw.
- 33 Set the control level in the 'COLD'

- position and tighten the trunnion screw.
- 34 Operate the control lever to check engagement of detents and full movement of both flaps, then return the lever to the 'COLD' position and check sealing of the outlet flap.
- 35 Reverse instructions 1 and 2.

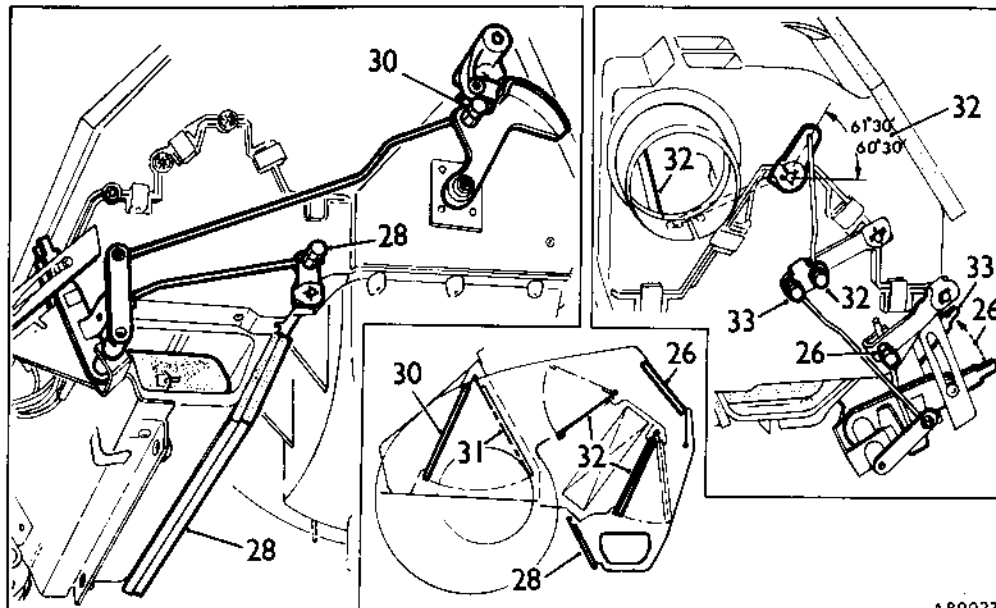

A80023

**WATER HOSES**

- Remove and refit
  - hose - feed
  - engine to heater
 80.25.07
- Hose - return - heater to engine return pipe 80.25.12

**Removing**

- 1 Drain the cooling system. 26.10.01.
- 2 Remove the fresh air duct. 80.15.31.
- 3 Slacken the clips and remove the hoses.

**Refitting**

- 4 Reverse instructions 1 to 3.

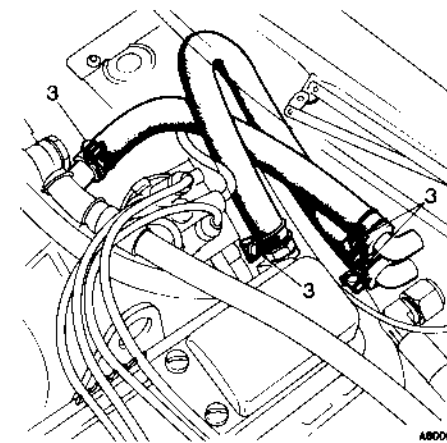

A80024

## Introduction

82.00.00

The air conditioning system is designed to provide a two level output. The upper level provides cool air at face level for increased comfort in hot climates. The lower level provides either cool or warm air at foot level and an air supply available to the screen.

The principal component of the system is the air conditioner unit. It governs all airflows and contains one blower motor and two matrixes. A cold matrix is cooled by the cold refrigerant circuit and a hot matrix heated by the hot water circuit.

All incoming air is accelerated by the blower motor running at one of three speeds. When the blower motor is selected OFF a flap prevents outside air entering the system. All incoming air is first cooled, dehumidified and cleaned by passing through the cold matrix. The air is then passed to the distribution and hot matrix area.

Cold air is delivered from the central fascia vent and the two end fascia vents at a temperature controlled by the cold temperature control system.

Cold air or hot air is delivered from the footwell outlets and screen outlets at a temperature controlled by a combination of both the cold temperature control system and the hot temperature control system.

Air extraction is from two air vent grilles in the vehicle body rear quarter panels.

The refrigerant circuit consists of a compressor at the front of the engine driven from a drive belt and electromagnetic clutch, a condenser with two fans in the nose of the vehicle, a receiver drier cylinder at the front of the engine bay and the cold matrix in the air conditioner unit. Hoses join the components.

The system is filled with refrigerant which must be subject to special precautions. It exists in the circuit both as a liquid and a vapour.

Service personnel who are not familiar with air conditioned vehicles must study Servicing 82.30.00. A full understanding of this section must be obtained before breaking into the system. Failure to observe this instruction may result in severe personal injury.

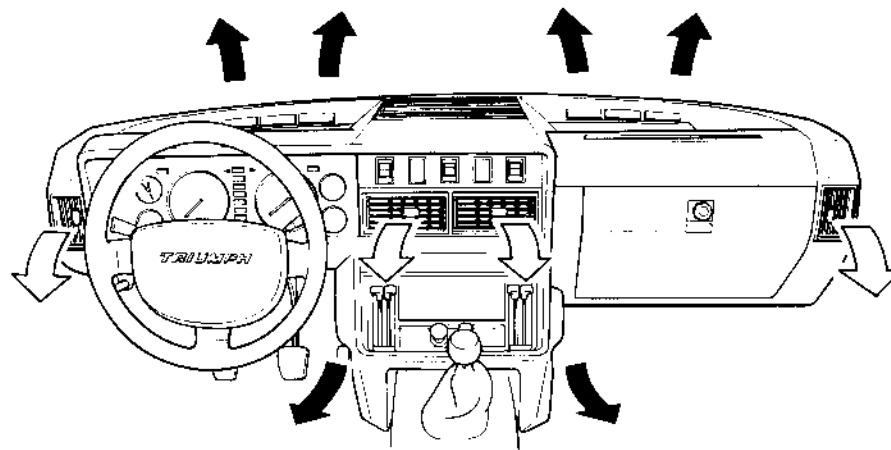

A82 012

## Hot water circuit

The function of the hot water circuit is to heat the hot matrix. The hot water flow is induced by the engine water pump. Hot water is drawn from the water transfer housing at the rear of the cylinder head and passes through the water flow valve to the hot matrix. From the hot matrix outlet the flow is forward below the carburettors to enter the water pump cover. This entry is on the suction side of the water pump.

**Cold refrigeration circuit***Introduction*

The function of the refrigeration circuit is to cool the cold matrix. The circuit comprises the following main components:

- Compressor
- Condenser
- Receiver drier
- Expansion valve and cold matrix

Hoses are employed to transport the refrigerant between components.

*Compressor*

The compressor draws vaporized refrigerant from the cold matrix. It is compressed, and thus heated, and passed on to the condenser as a hot, high pressure vapour.

*Condenser*

The condenser is mounted at the front of the car. Its function is to remove heat from the refrigerant and disperse it into the atmosphere. It is delivered with hot, high pressure vapour. Air flow across the tubes, induced by vehicle movement and assisted by two electric fans, cools the vapour, causing it to condense into a high pressure liquid. As this change of state occurs a large amount of latent heat is released.

*Receiver drier*

This unit filters, removes moisture, and acts as a reservoir for the liquid. To prevent icing inside the system, extreme precautions are taken during servicing to exclude moisture. The receiver drier should be considered as a second stage insurance to prevent the serious consequences of ice obstructing the flow. A sight glass provided in the unit top enables a visual check to be made of the high pressure liquid flow.

*Expansion valve and cold matrix*

High pressure liquid refrigerant is delivered to the expansion valve. A severe pressure drop occurs across the valve and as the refrigerant enters the cold matrix space at a temperature of approximately  $-6^{\circ}\text{C}$  it boils and vaporizes. As this change of state occurs, a large amount of latent heat is absorbed. The cold matrix is therefore cooled and as a result heat is extracted from the air flowing across the matrix.

*Second cycle*

Vaporized refrigerant is then drawn from the the cold matrix by the compressor and a second cycle commences.

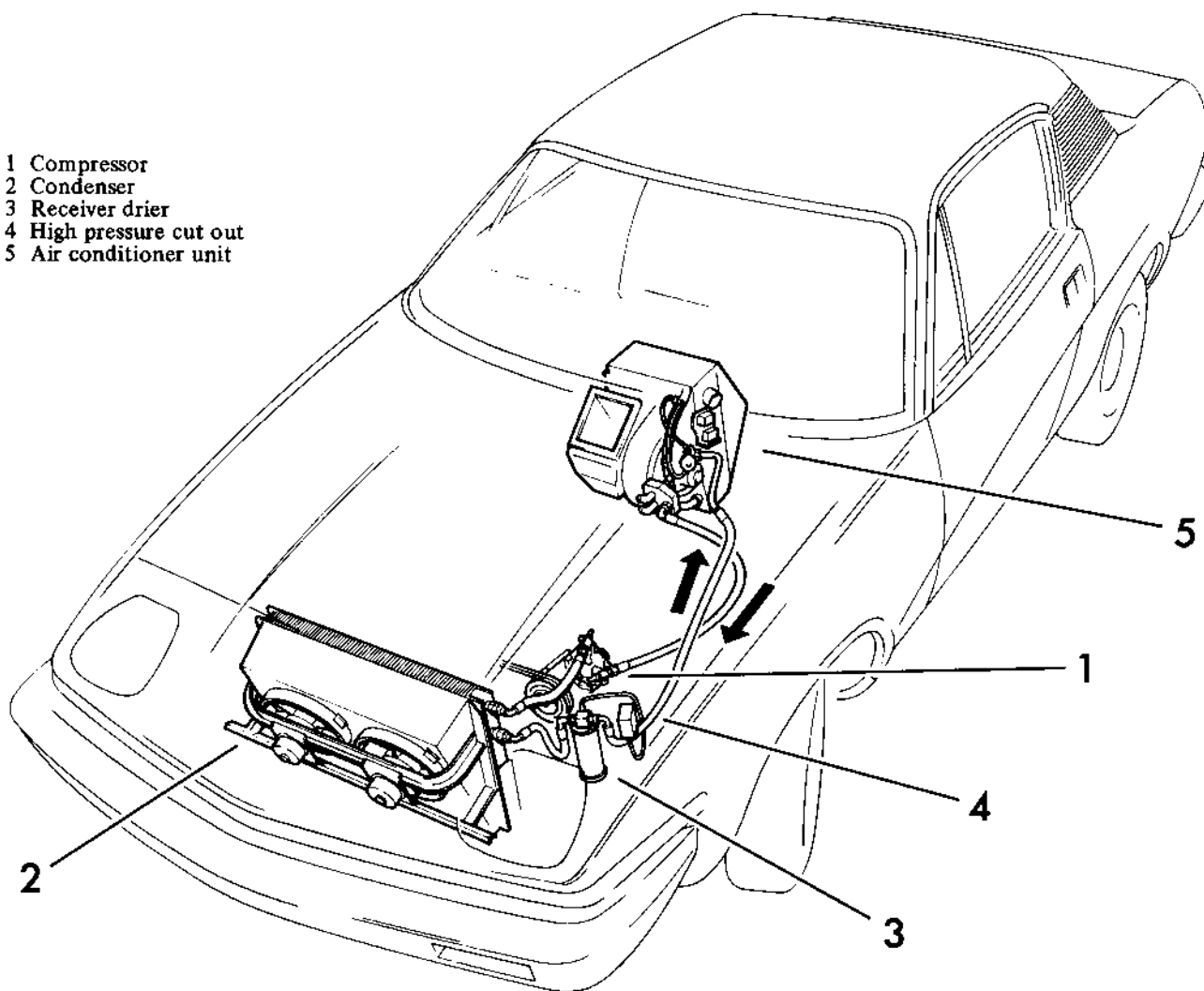

- 1 Compressor
- 2 Condenser
- 3 Receiver drier
- 4 High pressure cut out
- 5 Air conditioner unit

## COMPRESSOR

### Data

82.10.00

### Compressor

Manufacturer . . . . . York Division of Borg Warner, York, U.S.A.  
 Model . . . . . 210  
 Triumph part no. . . . . RKC 0456

Cylinders . . . . . 2 in line  
 Capacity . . . . . 10.3 cu in/rev  
 Bore . . . . . 1.875 in  
 Stroke . . . . . 1.866 in  
 Crankcase and liners . . . . . Die-cast light alloy with case in cast iron liners

Head . . . . . Die-cast light alloy  
 Valves and valve plate . . . . . Two-way non-return valve unit above each cylinder. Assembled onto a common steel valve plate

Front plate, rear plate and base plate . . . . . Die-cast light alloy  
 Main bearings . . . . . Two ball bearings  
 Crankshaft nose tapping . . . . .  $\frac{1}{8}$  -24 UNF 1.250 deep  
 Lubrication . . . . . Refrigerant compressor oil.  
     Distributed by splash and pressure differential

Lubrication plugs . . . . . Two located on crankcase sides.  
 Mounting tappings . . . . .  $\frac{1}{8}$  -16 UNC 0.620 in deep  
 Maximum permissible speed . . . . . 6,000 rev/min  
 Weight . . . . . 14.6 lb

### Clutch

Manufacturer . . . . . Warner Electric  
 Triumph part no. . . . . TKC 2019

Current . . . . . 4.5 amp.  
 Pulley nominal diameter . . . . . 6.0 in

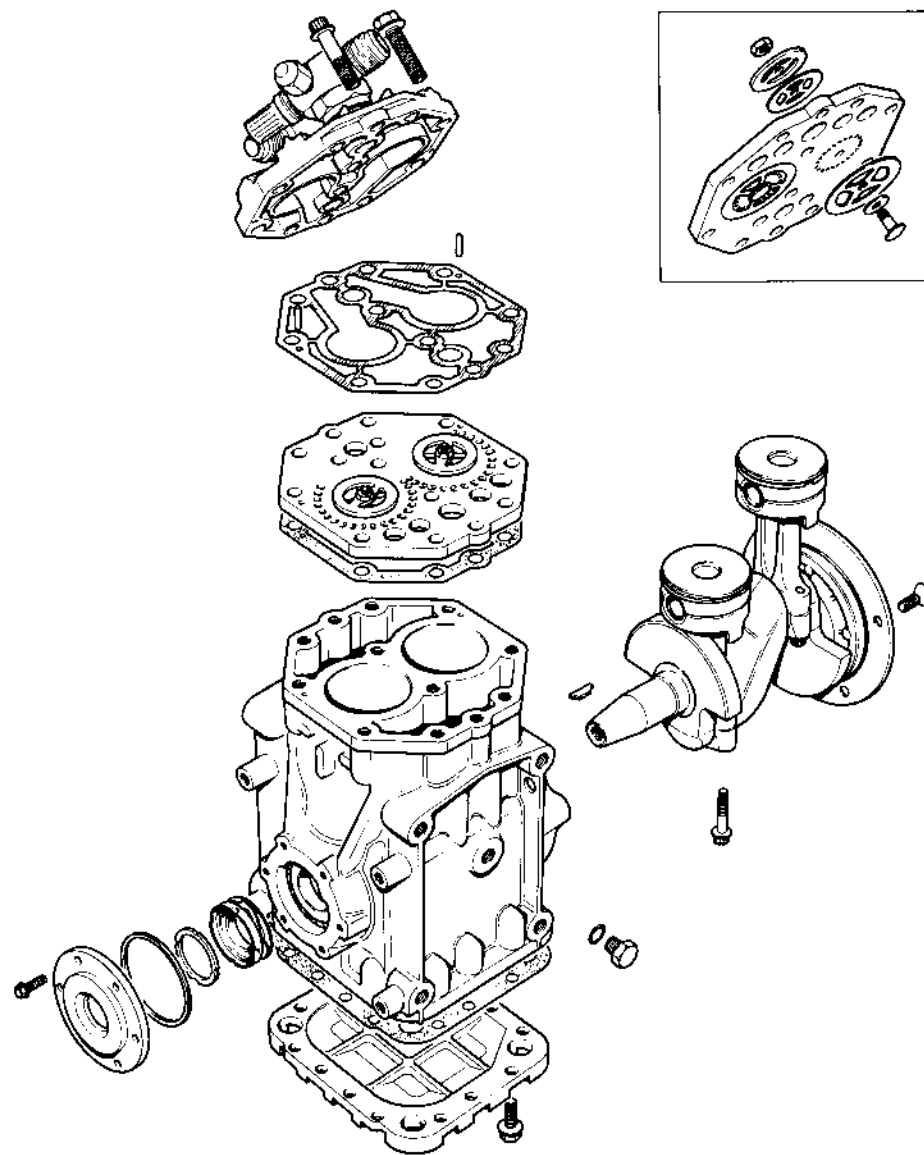

**COMPRESSOR**

Drive belt — adjust

82.10.01

- 1 Drive the vehicle onto a ramp.
- 2 Raise the ramp.
- 3 At the transverse support bracket slacken two bolt assemblies.
- 4 At the longitudinal support bracket slacken two bolt assemblies.
- 5 Lower the ramp.
- 6 At the exhaust bracket slacken one bolt assembly.
- 7 Slacken the locknut.
- 8 Slacken three main mounting nuts.
- 9 Rotate the adjustment nut — clockwise to tighten the belt or anti-clockwise to slacken the belt.
- 10 Tighten three main mounting nuts.
- 11 Check the belt tension. This should be 0.75 to 1.00 in (19 to 25 mm) at the mid-point of the belt run.
- 12 If a correction is required repeat operations 8 to 11.
- 13 Tighten the locknut.
- 14 At the exhaust bracket tighten one bolt assembly.
- 15 Raise the ramp.
- 16 At the longitudinal support bracket tighten two bolt assemblies.
- 17 At the transverse support bracket tighten two bolt assemblies.

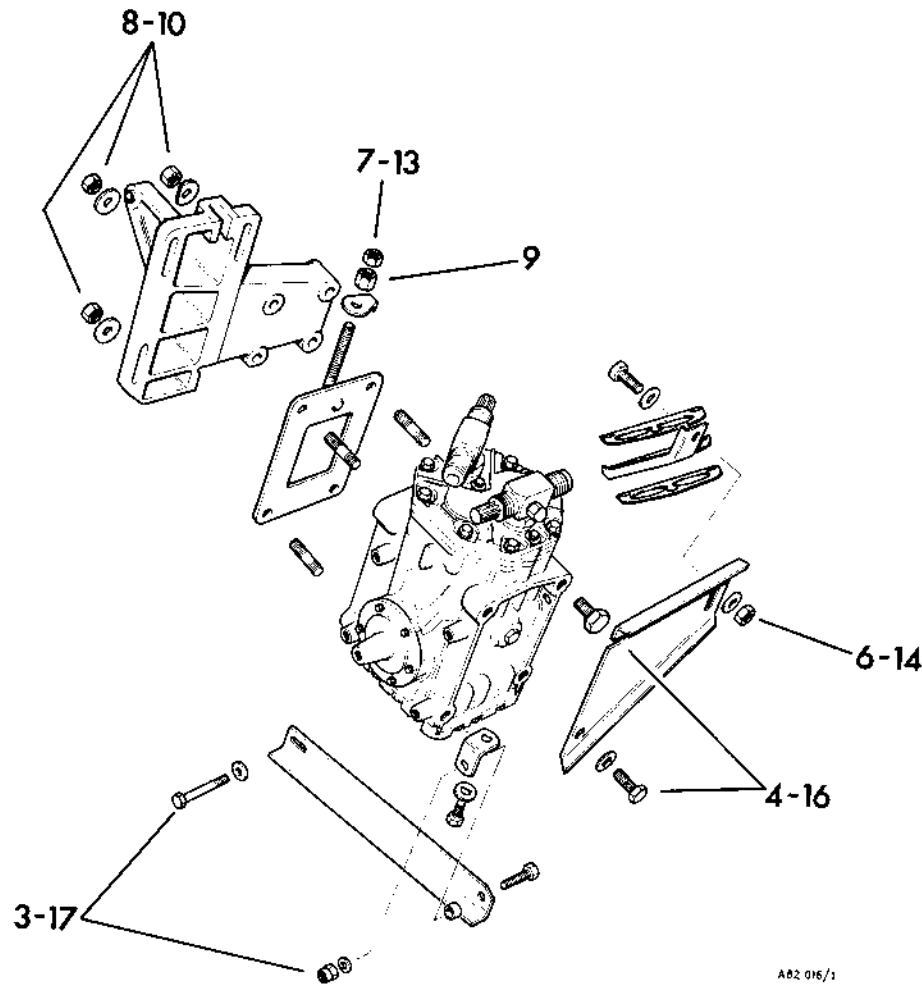

AB2 016/1

**COMPRESSOR**

Drive belt — remove and refit

82.10.02

**Removing**

- 1 Perform 82.10.01, operations 1 to 8.
- 2 Rotate the adjustment nut anti-clockwise to lower the compressor.
- 3 Slacken the fan blade bolt assemblies to enable the fan blades to be slid forward to provide the required clearance.
- 4 Remove the belt. Do not stretch the belt over the wide section of the clutch pulley. Run the belt off the crankshaft pulley.

**Refitting**

- 5 Fit the belt.
- 6 Tighten the fan blade bolt assemblies.
- 7 Perform 82.10.01, operations 9 to 17.

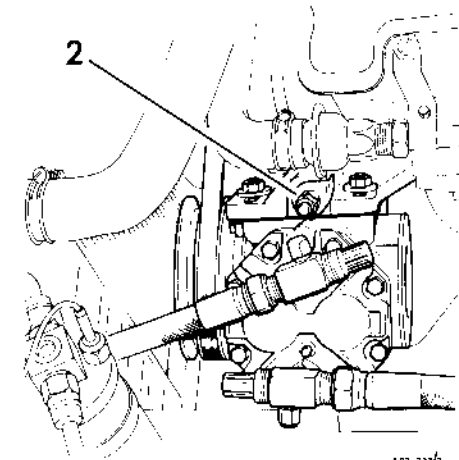

A87 233/2

## COMPRESSOR

Clutch – remove and refit 82.10.08

### Removing

- 1 Remove the radiator, see 26.40.01.
- 2 Disconnect the clutch electrical connection.
- 3 Use a slave wire between the battery positive terminal and the clutch electrical connection to energize the clutch. This action will lock the compressor crankshaft to the pulley.

**WARNING:** Do not energize the clutch through the vehicle harness as this would require the ignition circuit to be energised with the danger of an engine start during the operation.

- 4 Retain the pulley and remove the centre bolt.
- 5 Retain the pulley and screw a 0.625 in UNC slave bolt into the thread provided to withdraw the pulley from the tapered shaft.

**CAUTION:** Take care to screw the slave bolt in square to prevent a 'cross thread' condition.

- 6 Remove four bolts and lift away the clutch coil.

### Refitting

- 7 Position the clutch coil with the wire emerging upwards. Secure with four bolts.
- 8 Ensure that the key is fitted to the tapered shaft.
- 9 Fit the pulley to the tapered shaft.
- 10 Electrically energise the clutch.
- 11 Retain the pulley and fit the centre bolt. Torque load to 16 lbf ft (2.2 kgf m).
- 12 Connect the clutch electrical connection.
- 13 Adjust the drive belt, see 82.10.01.
- 14 Fit the radiator, see 26.40.01.

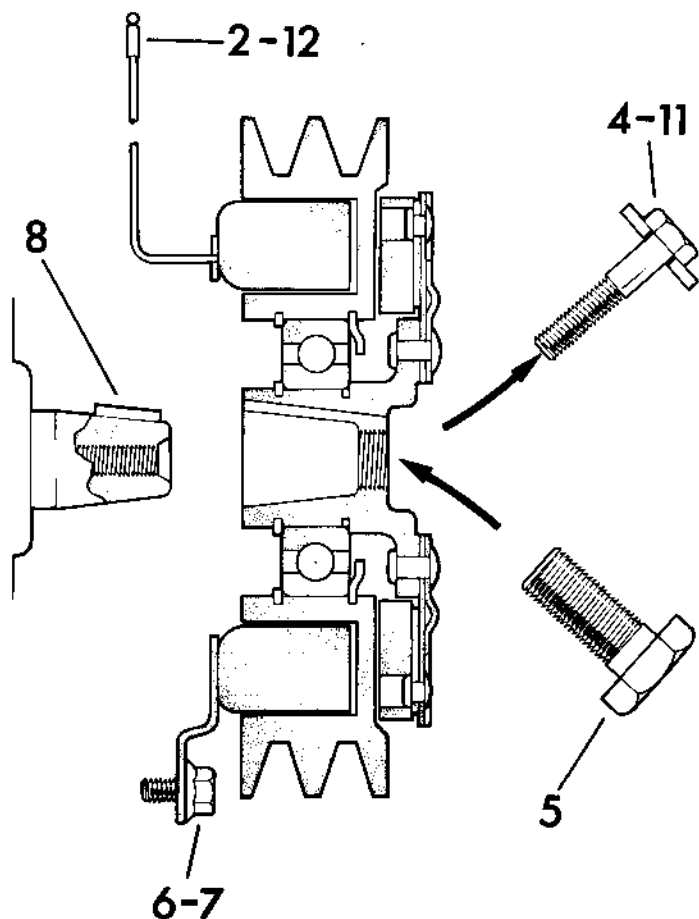

M110/1

## COMPRESSOR

Remove and refit 82.10.20

## Removing

- 1 Drive the vehicle onto a ramp.
- 2 Connect gauge set, see 82.30.01.
- 3 Discharge - compressor only, see 82.30.20.
- 4 Protect the eyes with safety goggles and wear gloves during operation 5.
- 5 Unscrew two service valve union nuts. Blank exposed compressor connections immediately.
- 6 Remove the fresh air duct, see 80.15.31.
- 7 Remove two bolts, spring washers and washers. Lift away the fan guard.
- 8 Raise the ramp.
- 9 At the transverse support bracket slacken the right-hand bolt assembly and remove the left-hand bolt assembly.
- 10 At the longitudinal support bracket slacken the upper bolt assembly and remove the lower bolt assembly
- 11 *Early vehicles only:*  
Remove the engine stabilizer, see 12.45.16.
- 12 At the front left-hand engine mounting remove one nut and washer.
- 13 Provide a jack under the engine with a large block of wood to distribute the load under the engine sump.
- 14 Jack up the engine to the position where the front left-hand engine mounting stud remains just retained in the sub frame bracket.

**NOTE:** Do not allow the stud to come out of the bracket as insertion may prove difficult.

- 15 Lower the ramp.
- 16 At the exhaust bracket remove one bolt assembly.
- 17 Withdraw the longitudinal support bracket.
- 18 Slacken the locknut.
- 19 Slacken three main mounting nuts.
- 20 Rotate the adjustment nut anti-clockwise to lower the compressor.

- 21 Remove the belt from the compressor pulley. Do not stretch the belt over the wide section of the clutch pulley. Run the belt rearwards off the crankshaft pulley.
- 22 Remove three main mounting nuts and washers. Lift the compressor from the vehicle.
- 23 If necessary detach the following items from the compressor:
  - a Adjustment plate assembly.
  - b One bolt.
  - c One bolt, washer and right angle bracket.
  - d Three studs.
  - e Clutch, see 82.10.08.

## Refitting

- 24 If necessary attach the items listed at operation 23 above to the compressor.

**NOTE:** Item d, the shorter stud threads screw into the compressor tappings. The lower rear tapping is not fitted with a stud.

- 25 Position the compressor to the vehicle. Secure with three washers and nuts finger tight.
- 26 Fit the belt.
- 27 Adjust the belt, see 82.10.01, operations 9 to 12.
- 28 Tighten the locknut.
- 29 Position the longitudinal support bracket.
- 30 At the exhaust bracket fit one bolt assembly finger tight.
- 31 Raise the ramp.
- 32 Lower the jack.
- 33 At the front left-hand engine mounting fit one washer and nut.
- 34 *Early vehicles only:*  
Fit the engine stabilizer, see 12.45.16.
- 35 At the longitudinal support bracket fit and tighten the lower bolt assembly and tighten the upper bolt assembly.
- 36 At the transverse support bracket fit and tighten the left-hand bolt assembly and tighten the right-hand bolt assembly. Ensure that the right angle bracket is correctly aligned.
- 37 Lower the ramp.
- 38 At the exhaust bracket tighten one bolt assembly.

- 39 Position the fan guard. Secure with two bolts, spring washers and washers.
- 40 Fit the fresh air duct, see 80.15.31.
- 41 Connect two service valve union nuts. Use refrigerant compressor oil on all mating surfaces to assist leakage prevention. Position the service valves for the best hose alignment.

- 42 Evacuate - compressor only, see 82.30.21.
- 43 Charge - compressor only, see 82.30.23.
- 44 Perform a leak test on any disturbed joints, see 82.30.09.
- 45 Functional check, see 82.30.16.
46. Disconnect gauge set, see 82.30.01.

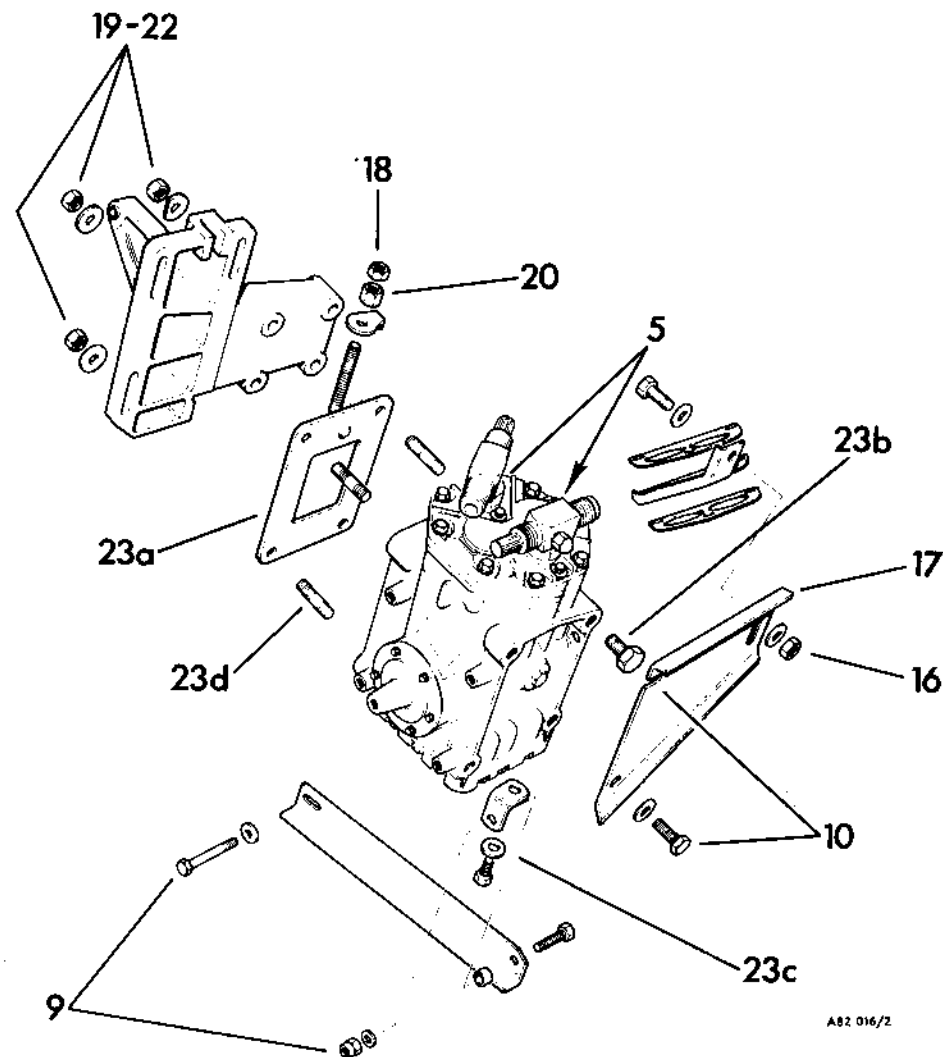



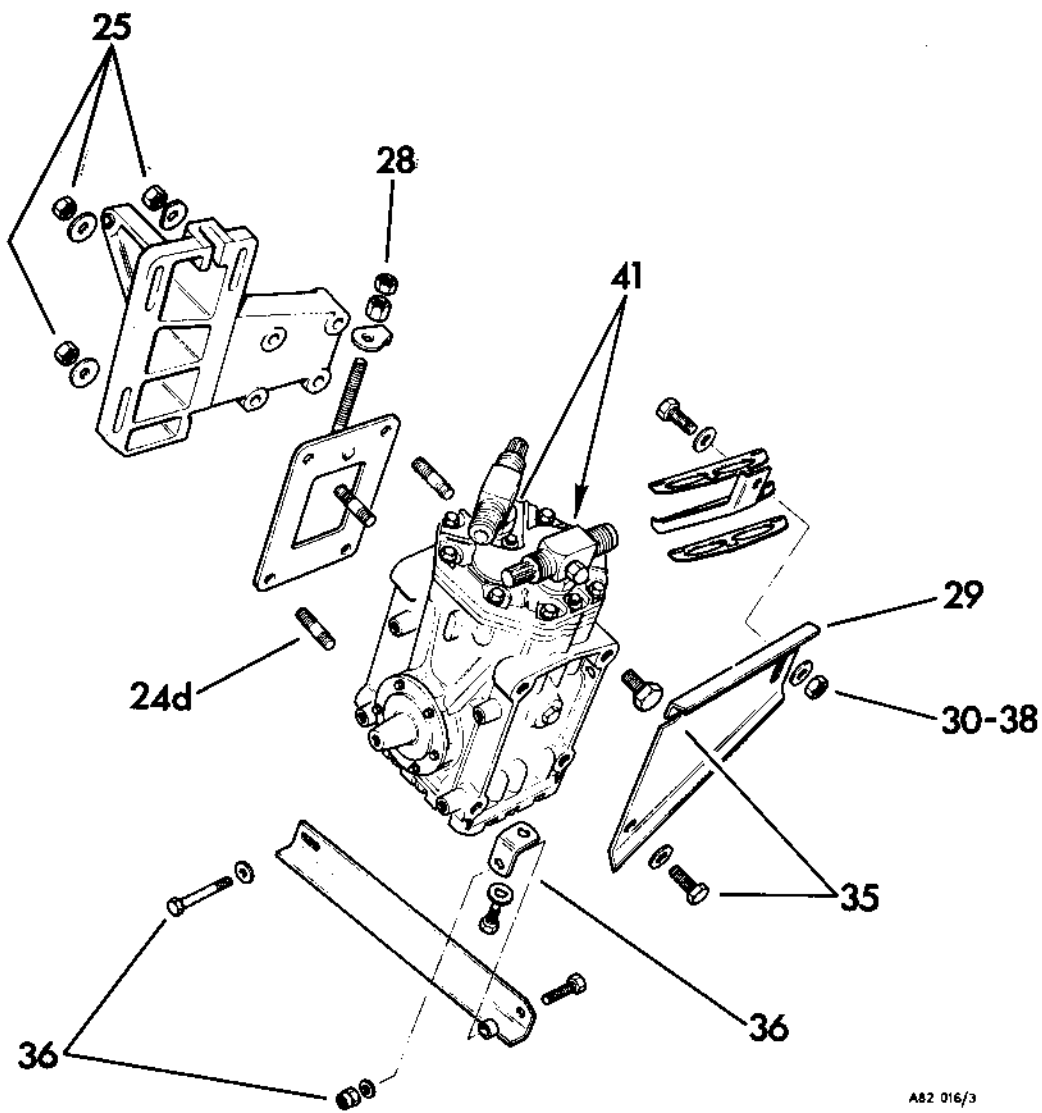

AB2 016/3

## CONDENSER FAN MOTOR

Remove and refit

82.15.01

### Removing

- 1 Drive the vehicle onto a ramp.
- 2 Raise the ramp.
- 3 Using a small screwdriver slacken the grub screw to release the fan.
- 4 Remove the fan from the motor shaft.
- 5 Disconnect the fan motor harness plug.
- 6 Remove three nuts, anti-vibration washers, washers, washers and bolts.
- 7 Withdraw the fan motor from the mounting assembly. Take care not to damage the wires. To allow the grommet to pass through the aperture tilt the fan motor. If the grommet remains obstructive pull it from the aperture.

- 8 Remove the fan motor from the vehicle. It may be necessary to slightly bend the vehicle body front cross-member to achieve this operation.

### Refitting

- 9 Ensure that the fan is positioned in the cowling.
- 10 Reverse 1 to 8. Insert the fan motor to the mounting assembly with the wires emerging downwards for improved water sealing. Fit the fan to the motor shaft with the grub screw aligned to a motor shaft recess.

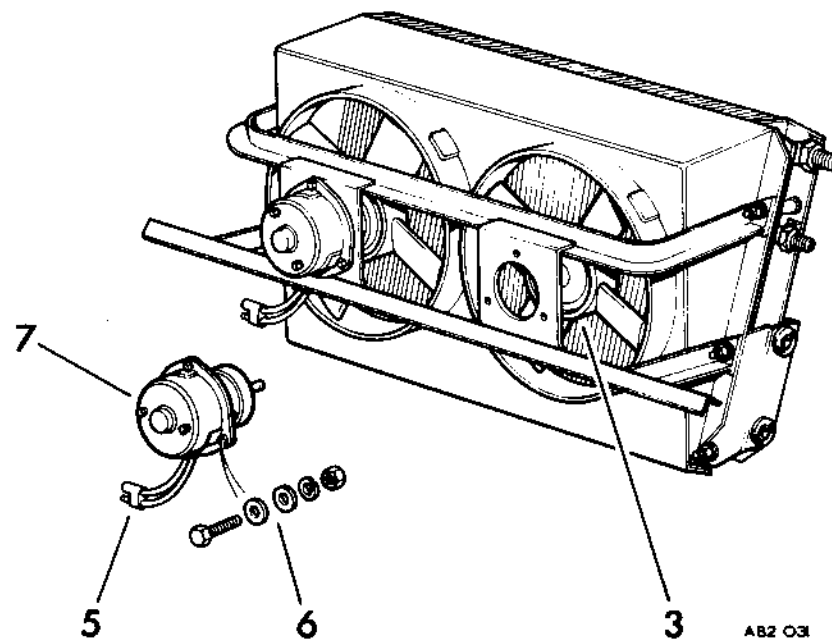

AB2 03

**CONDENSER**

Remove and refit 82.15.07

**Removing**

- 1 Remove the condenser and fan assembly, see 82.15.10.
- 2 Remove two top nuts, anti-vibration washers, washers, washers and shorter bolts.
- 3 Remove two middle nuts, anti-vibration washers, washers, washers and longer bolts.
- 4 Remove the fan motor mounting assembly.
- 5 Remove one nut, anti-vibration washer, washer, washer and bolt. Remove the left-hand bracket which includes two mounting rubbers.
- 6 Remove one nut, anti-vibration washer, washer, washer and bolt. Remove the right-hand bracket which has no mounting rubbers.

**Refitting**

- 7 Reverse 1 to 6.

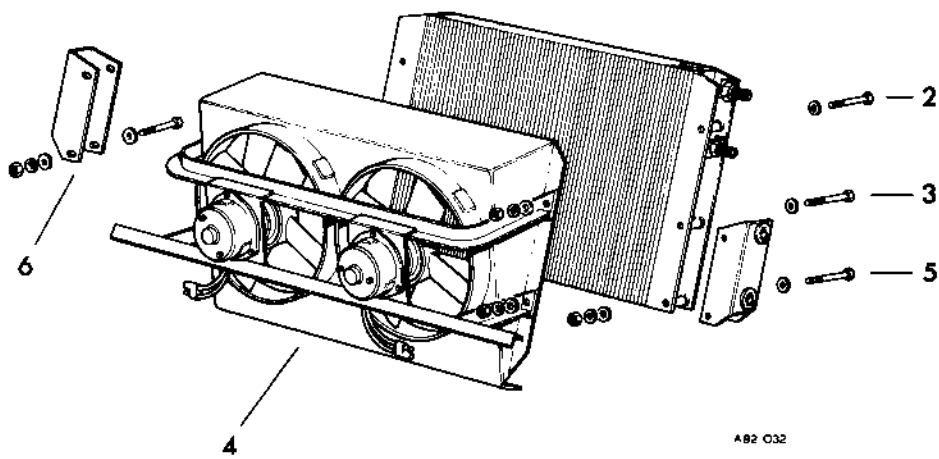

AB2 C32

**CONDENSER AND FAN ASSEMBLY**

Remove and refit 82.15.10

**Removing**

- 1 Drive the vehicle onto a ramp.
- 2 Select the master light switch to raise the headlamps.
- 3 Isolate the battery to extinguish the headlamps.
- 4 Connect gauge set, see 82.30.01.
- 5 Discharge - complete system, see 82.30.05.
- 6 Remove the radiator, see 26.40.01.
- 7 Protect the eyes with safety goggles and wear gloves during operation 8.
- 8 Carefully disconnect two hose connections. Use two spanners at each joint to protect the delicate condenser pipe joints. Blank exposed connections immediately.
- 9 Raise the ramp.
- 10 Remove four bolts, lock washers and washers. Remove the radiator mounting cross-member.
- 11 Disconnect two fan motor harness plugs.
- 12 Slacken two right-hand bracket bolt assemblies.

**NOTE:** The right-hand bracket is provided with slots as shown to facilitate withdrawal and positioning of the assembly and to ensure that the brackets are drawn up firmly against the body longitudinal members. Note that the left-hand bracket has no slots.

- 13 Remove two nuts, lock washers and washers securing the fan motor mounting assembly rail.
- 14 Remove two left-hand longer side bolts, anti-vibration washers and washers.
- 15 Collect up the nut plate.
- 16 Remove two right-hand shorter side bolts, anti-vibration washers and washers.
- 17 Carefully withdraw the condenser and fan assembly downwards from the vehicle. Handle with care as the fins are easily damaged.

**Refitting**

- 18 Ensure that the two right-hand bracket bolt assemblies are slackened.
- 19 Reverse 9 to 17.
- 20 Connect two hose connections. Use refrigerant compressor oil on all mating surfaces to assist leakage prevention.
- 21 Fit the radiator, see 26.40.01.
- 22 Evacuate - complete system, see 82.30.06.
- 23 Connect the battery.
- 24 Charge - complete system, see 82.30.08.
- 25 Perform a leak test on any disturbed joints, see 82.30.09.
- 26 Select the master light switch to lower the headlamps.
- 27 Functional check, see 82.30.16.
- 28 Disconnect gauge set, see 82.30.01.

*Illustration on following page*

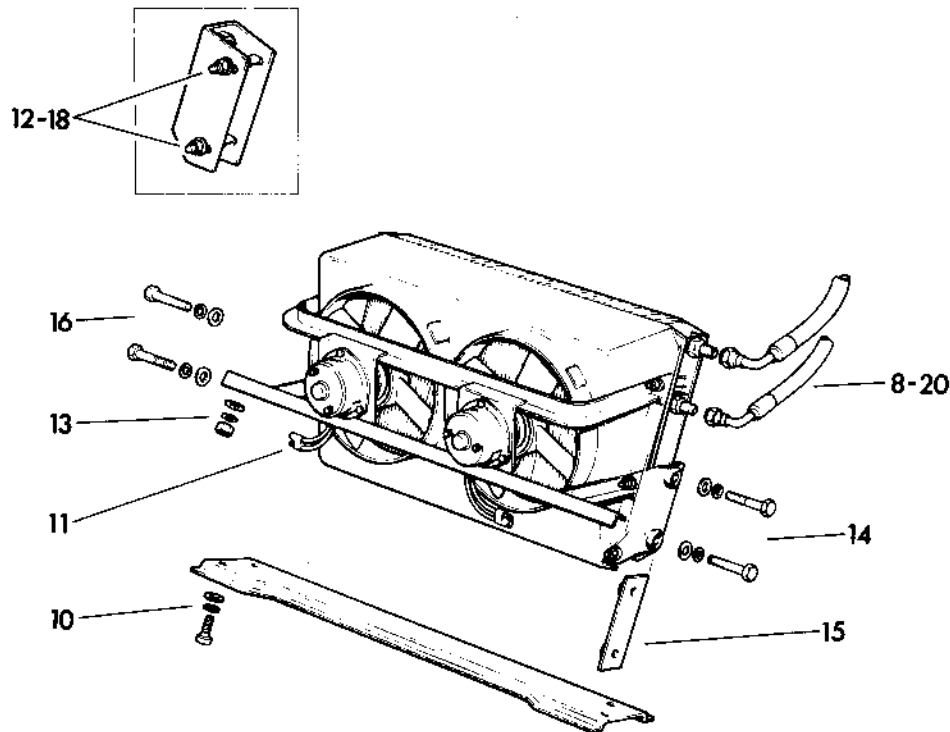

A82 030/1

## RECEIVER DRIER

Remove and refit 82.17.01

**CAUTION:** Immediate blanking of the receiver drier is important. Exposed life of the unit is only 15 minutes.

### Removing

- 1 Connect gauge set, see 82.30.01.
- 2 Discharge – complete system, see 82.30.05.
- 3 Protect the eyes with safety goggles and wear gloves during operations 4 and 5.
- 4 Carefully disconnect the capillary tube from the receiver drier. Blank exposed connections immediately.
- 5 Carefully disconnect two hose connections. Use a second spanner to support the squared hose adaptor. Blank exposed connections immediately.
- 6 Remove the clamp screw, washer, washer and nut.
- 7 Withdraw the receiver drier from the mounting bracket.

### Refitting

- 8 Insert the receiver drier into the mounting bracket with the inlet and outlet connections correct to the refrigerant circuit flow as shown.
- 9 Connect two hose connections finger tight. Use refrigerant compressor oil on all mating surfaces to assist leakage prevention.
- 10 Fit the clamp screw, washer, washer and nut.
- 11 Tighten two hose connections. Use a second spanner to support the squared hose adaptor.
- 12 Carefully connect the capillary tube to the receiver drier. Use refrigerant compressor oil on all mating surfaces to assist leakage prevention.
- 13 Evacuate – complete system, see 82.30.06.
- 14 Charge – complete system, see 82.30.08.
- 15 Perform a leak test on any disturbed joints, see 82.30.09.
- 16 Functional check, see 82.30.16.
- 17 Disconnect gauge set, see 82.30.01.

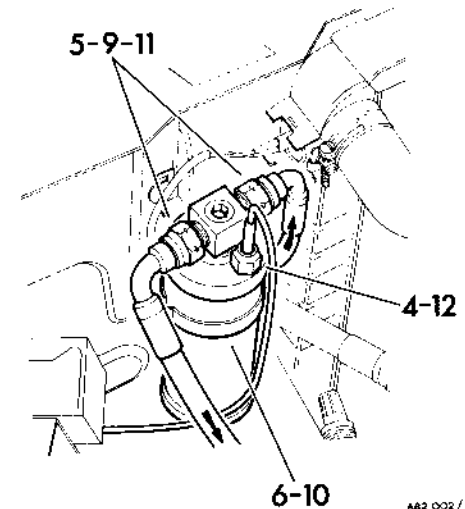

A82 002/1

**CONTROLS**

Description 82.20.00

**Control levers**

Lever A – controls the flow of cold air delivered from the central fascia vent. Moving lever A up to the OFF position will terminate the airflow. Moving lever A down to the MAX position will provide the maximum airflow. Any intermediate position may be used. This control operates through the direct linkage A to position flap A.

Lever B – directs the temperature required. Moving lever B up to the COLD position will provide maximum cooling. Moving lever B down to the HOT position will provide maximum heating. Any intermediate position may be used. This control operates through the non-direct linkage B to provide an input to both the cold thermostat and the hot thermostat. Lever B therefore influences the airflow from both the cold outlets and the hot outlets. After setting the position of lever B the cold temperature control system and/or the hot temperature control system will maintain an approximately constant interior temperature.

Lever C—is the master control to bring into action the cold refrigerant circuit and the blower motor. It also selects the input air—either fresh air at ambient temperature through the under bonnet fresh air duct or recirculated air from the vehicle interior.

Moving lever C up to the OFF position will electrically switch off the compressor electro-magnetic clutch, throttle jack (automatic vehicles only) and the two condenser fan motors. Flap C will be in the recirculate position so vehicle movement will not induce an airflow through the system.

Moving lever C slightly down to position MAX will electrically switch on the cold refrigerant circuit and the blower motor at its fastest speed. Flap C will remain in the recirculate position. This selection of lever C will provide the maximum cooling or the maximum heating condition.

Moving lever C further down to position 3 will maintain the cold refrigerant circuit electrically on and the blower motor at its fastest speed. Flap C will be traversed by the non-direct 'quick changeover' linkage C to the fresh position. Any intermediate position between MAX and 3 may be used.

Moving lever C slightly further down to position 2 will maintain the cold refrigerant circuit electrically on and the flap C at the fresh position. The blower motor will drop to its middle speed.

Moving lever C slightly further down to position 1 will maintain the cold refrigerant circuit electrically on and flap C at the fresh position. The blower motor will drop to its slowest speed.

Lever D—controls the flow of cold air or hot air delivered from the screen vents and footwell. Moving lever D up to the SCREEN position will provide the maximum airflow to the screen vents. Moving lever D down to the CAR position will provide the maximum airflow to the footwell. Any intermediate position may be used. This control operates through the direct linkage D to position flap D.

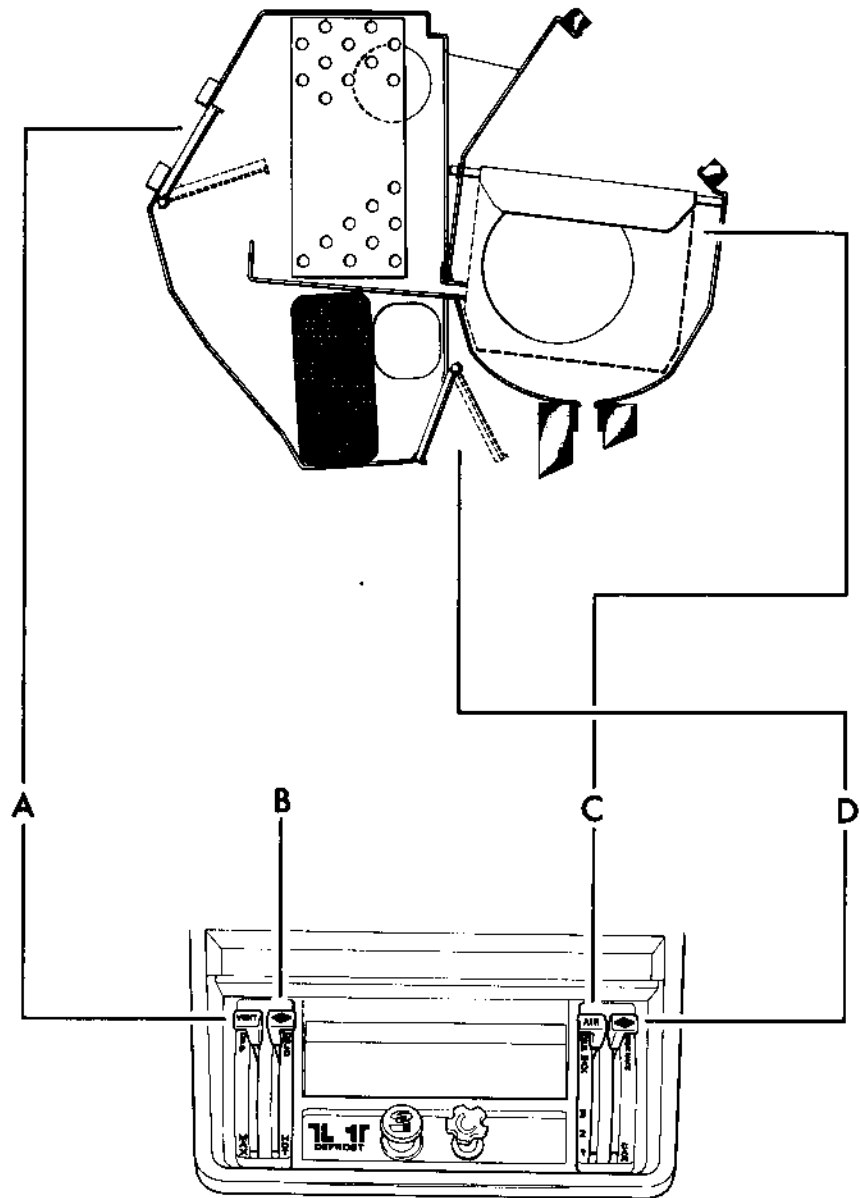

### Cold temperature control system

The principal unit of the system is the cold thermostat mounted on the left-hand side of the air conditioner unit. The thermostat receives two inputs. A capillary tube inserted into the air space of the cold matrix senses the cold matrix temperature. The driver's direction of the temperature required is transmitted by lever B and linkage B to position the thermostat lever. The output of the thermostat is an electric switch in the air conditioning electrical circuit. This controls indirectly the on-off switching of the compressor electro-magnetic clutch, throttle jack (automatic vehicles only) and the two condenser fan motors.

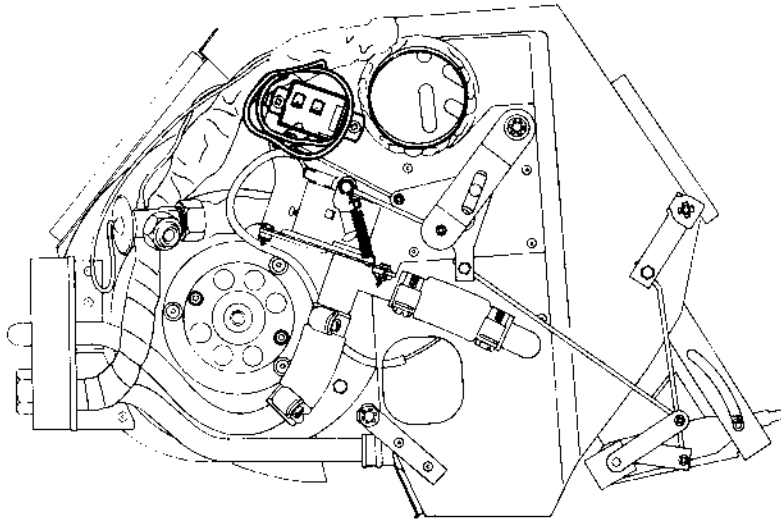

A82 O19

Cold thermostat

### Hot temperature control system

The principal unit of the system is the hot thermostat mounted on the left-hand side of the air conditioner unit. The thermostat receives two inputs. A capillary tube mounted against the downstream face of the hot matrix senses the hot matrix temperature. The driver's selection of the temperature required is transmitted by lever B and linkage B to position the thermostat lever. The output of the thermostat is a water valve in the hot water circuit. This controls the flow of hot water from the engine into the hot matrix.

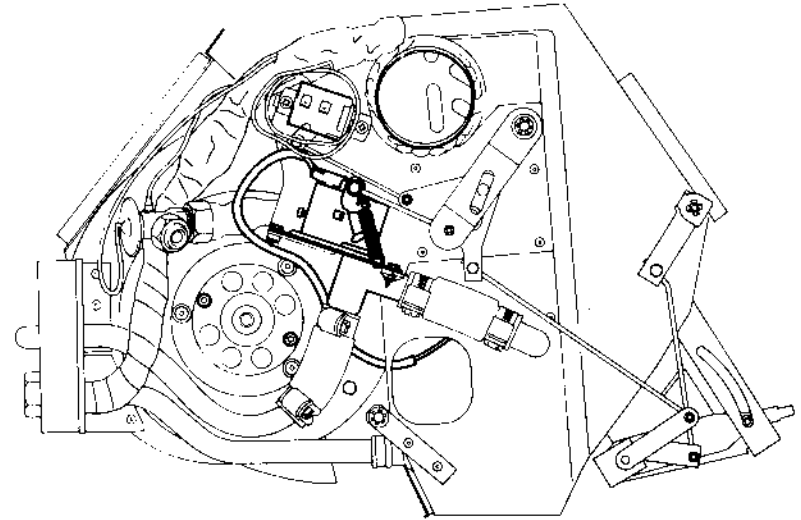

A82 O20

Hot thermostat

**Electrical circuit**

The function of the circuit is to control the on-off switching of the compressor electro-magnetic clutch, throttle jack (automatic vehicles only) and the two condenser fan motors. The circuit may be considered in two sections: the relay control circuit, and the power circuit.

**Relay control circuit**—Supply to the relay winding is from an ignition-controlled fuse. The earth path may be interrupted by the cold thermostat and by the driver's selection of lever 'C'. With lever 'C' up to the 'OFF' position, the circuit is broken. With lever 'C' selected to any other position. 'MAX', '3', '2' or '1', an earth path exists across the blower motor switch. The relay control circuit current is small, so the introduction of a blower motor speed control resistor in the circuit at positions 'MAX', '3' and '1' will have no consequence.

**Power circuit**—Actuation of the relay connects supply from the air conditioning fuse to the compressor clutch, throttle jack and the two condenser fan motors.

During the starting sequence the clutch and fan relays are energized when the key is in the No. 2 (Ignition) position. They are not energized when the key is in the 'Auxiliary' or 'Start' positions.

The circuit to the compressor clutch and throttle jack may be interrupted by the delay circuit as detailed below and by the high pressure cut-out which is a safety feature not subject to continuous cycling. The two condenser fan motors are controlled directly by the relay but these units may also be selected independently by the radiator switch as detailed below.

**Delay circuit**—This circuit is included to prevent a severe momentary voltage drop in the vehicle electrical system that would occur if the compressor clutch, throttle jack and the two condenser fan motors were allowed to 'cut in' simultaneously.

The circuit allows the two condenser fan motors to 'cut in' when the relay energizes. An acceptable first voltage drop occurs and the recovery is quick as the alternator output is rebalanced to the additional load.

The delay circuit flasher unit also first receives current when the relay energizes. This current heats a metal ribbon causing expansion which finally allows a metal vane to relax and the contacts to close.

The delay circuit relay is energized to hold the condition and the compressor clutch and throttle jack 'cut in'. A second acceptable voltage drop occurs and again recovery is quick as the alternator output is rebalanced to the additional load.

This action is repeated each time the air conditioning circuit is manually selected by lever 'C', or automatically switched on-off by the cold temperature control system.

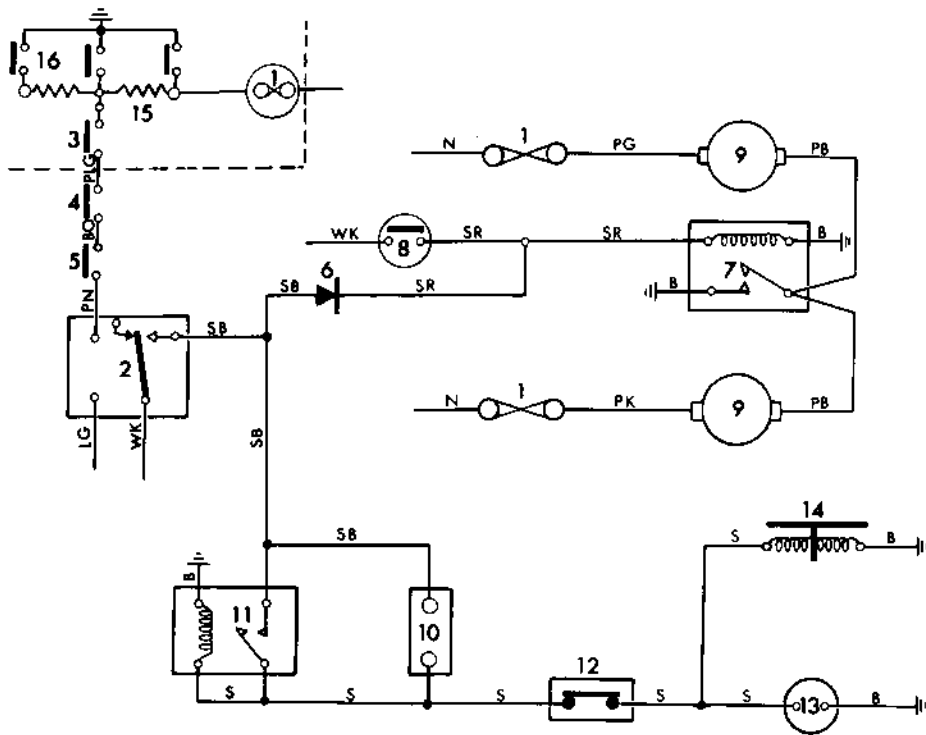
**1 Fuses****Relay control circuit**

- 2 Relay
- 3 Cold thermostat
- 4 Full throttle cut-off switch
- 5 Air conditioning cut-out switch
- 6 Diode
- 7 Fan relay
- 8 Radiator thermostat

**Power circuit**

- 9 Condenser fan motors
- 10 Delay circuit flasher unit
- 11 Delay circuit relay
- 12 High pressure cut-out
- 13 Compressor clutch
- 14 Throttle jack (automatic vehicles only)

**Other components**

- 15 Blower motor resistors
- 16 Blower motor switch

**Colour code**

- B Black
- G Green
- K Pink
- LG Light Green
- N Brown
- O Orange
- P Purple
- R Red
- S Slate
- W White
- Y Yellow

### High pressure cut out

The unit is a safety feature to protect the refrigeration circuit from excessive pressure. It is not subject to continuous cycling during normal system operation.

A capillary tube senses the refrigerant pressure at the receiver drier. This pressure governs an electrical switch within the unit.

The switch is included in the electrical circuit. If the refrigerant pressure rises to the 'cut out' pressure the electrical circuit to the compressor clutch and throttle jack (automatic vehicles only) is interrupted. The compressor electro magnetic clutch reverts to the off condition and the refrigerant pressure is prevented from rising further.

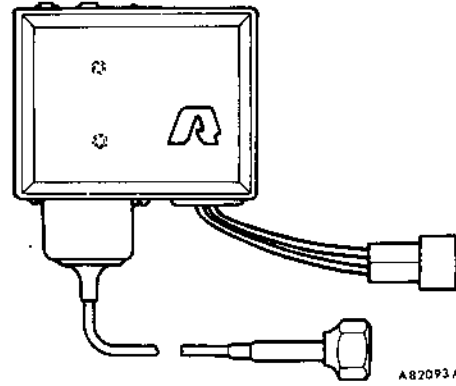

### Radiator switch

This item is not strictly a component of the air conditioning system. Its function is to actuate if the engine coolant temperature should reach a high level. Advantage of the two condenser fan motors is then taken to assist in cooling the radiator.

**NOTE:** As the temperature of the coolant in the upper section of the radiator may reach a high level immediately after the vehicle is parked, and the electrical supply to the radiator switch is direct from a battery control fuse, it is possible for the two fans to start running while the vehicle is parked and unattended. The run should only continue for a short period until the radiator has cooled. Under certain vehicle operating conditions this action may be considered as normal.

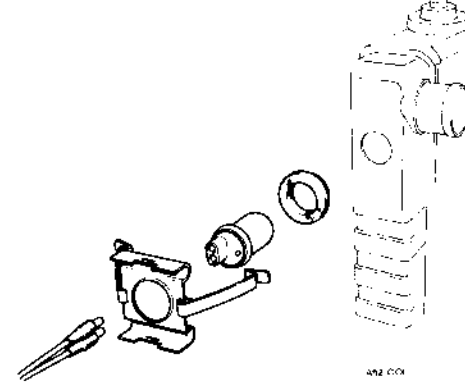

### Throttle jack

*The throttle jack is fitted to vehicles equipped with both air conditioning and automatic transmission.*

This unit consists of a solenoid coil and plunger. It is included to maintain an approximately constant engine idle speed both with the compressor clutch free and with the compressor clutch engaged to apply the compressor drive load to the engine.

With the air conditioning system switched out the plunger is retracted to an unemploy position under the action of a spring.

With the air conditioning system switched in the solenoid coil is energised to extend the plunger to provide a new stop position for the carburettor throttle linkage.

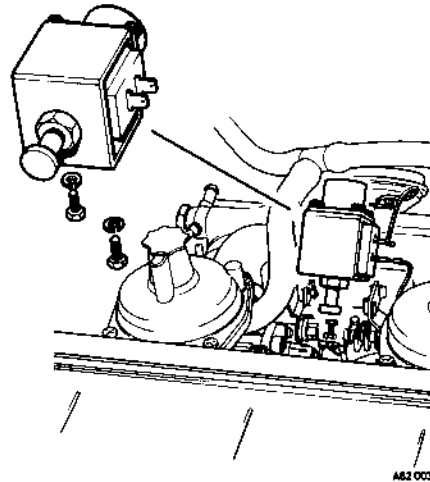

# CONTROL SUMMARY

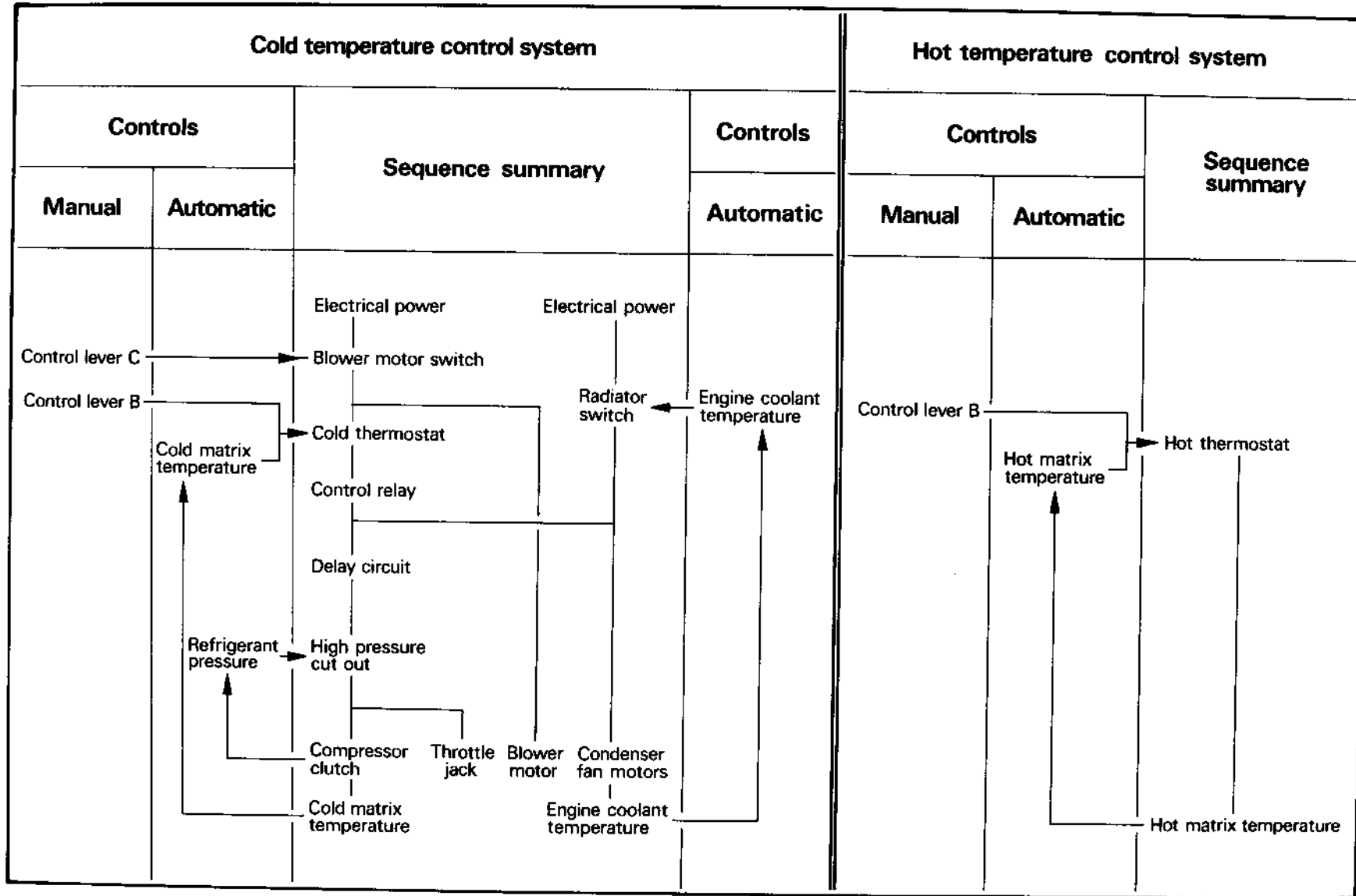



## CONTROLS

Radiator switch -- remove and  
refit 82.20.09

### Removing

- 1 Isolate the battery.
- 2 Pull off two electrical connections.
- 3 Release the rear spring clip from the radiator flange. Swing the bracket forward. Release the front spring clip from the radiator flange.
- 4 Using a wide blade screwdriver, carefully prise the switch outwards from the rubber seal.
- 5 Remove the rubber seal.

### Refitting

- 6 Fit the rubber seal. Fit a new rubber seal if available.
- 7 Insert the switch. Position the electrical connection pedestal forward as shown to facilitate operation 8 below.
- 8 Engage the front spring clip to the radiator flange. Swing the bracket rearward to align correctly to the switch. Engage the rear spring clip to the radiator flange.
- 9 Push on two electrical connections. The connections may be fitted either way round.
- 10 Connect the battery.

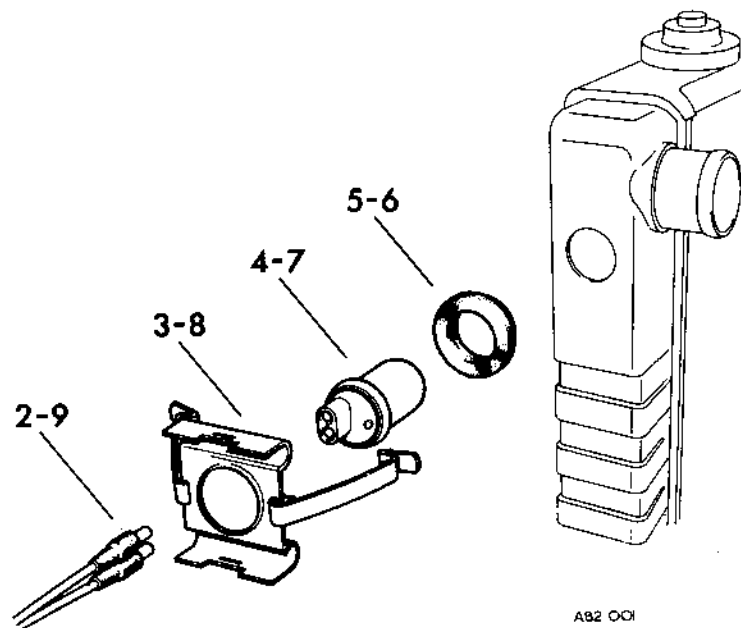

A82 001

**CONTROLS**

**Cold thermostat – remove and refit** 82.20.18

**Removing**

- 1 Isolate the battery.
- 2 Remove the fascia, see 76.46.01.
- 3 Disconnect two Lucar connectors.
- 4 Hold the cold thermostat trunnion hexagon and slacken the screw. Detach the control rod.
- 5 Free the capillary tube from the sealer below the refrigerant outlet pipe.
- 6 Centre punch and drill out two rivets. Use a  $\frac{1}{4}$  in drill.
- 7 Carefully withdraw the capillary tube from the air space of the cold matrix.
- 8 Collect up the split rubber grommet.
- 9 Remove the cold thermostat from the vehicle.

**Refitting**

- 10 Bend the capillary tube of the new cold thermostat to the correct shape. Use the old unit as a guide and bend the end as shown.
- 11 Fit two spire nuts FJ 2544 to the mounting bracket.
- 12 Thread the capillary tube between the refrigerant outlet pipe and the case. Insert the capillary tube end into the air space of the cold matrix to achieve the position shown.
- 13 Fit the split rubber grommet AAP 0165.
- 14 Coil the surplus length of the capillary tube as shown. Ensure that the coil does not extend outboard of the cold thermostat. Position the cold thermostat against the mounting bracket. Secure with two screws YZ 3404.
- 15 If necessary restore the sealer below the refrigerant outlet pipe.
- 16 Attach the control rod. Adjust linkage B, see 82.25.08.
- 17 Connect two Lucar connectors. The connectors may be fitted either way round.
- 18 Fit the fascia, see 76.46.01.
- 19 Connect the battery.
- 20 Functional check, see 82.30.16.

21 If the operation of the cold thermostat is suspect an adjustment may be made by amending the position of the capillary tube in the air space of the cold matrix. Access to achieve this operation may be obtained by removing the fascia centre grille, see 76.55.14.

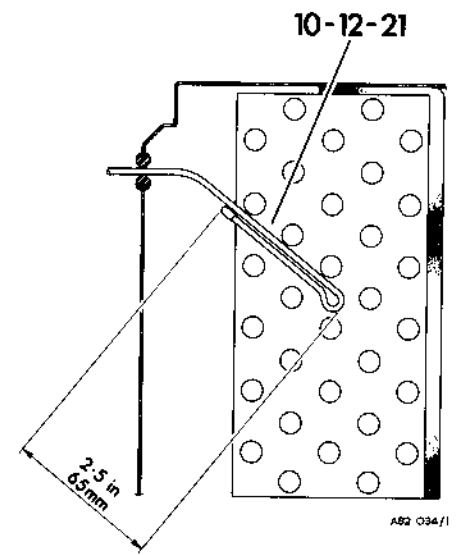
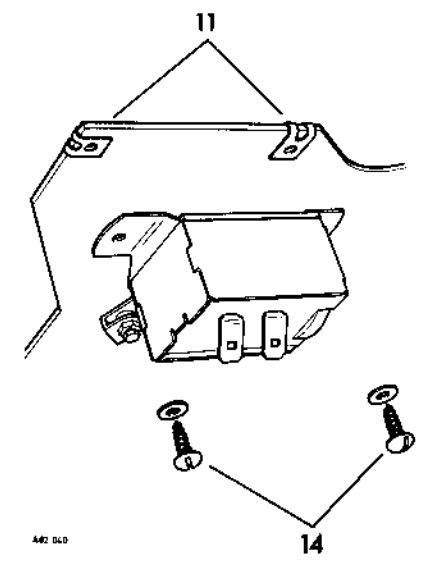
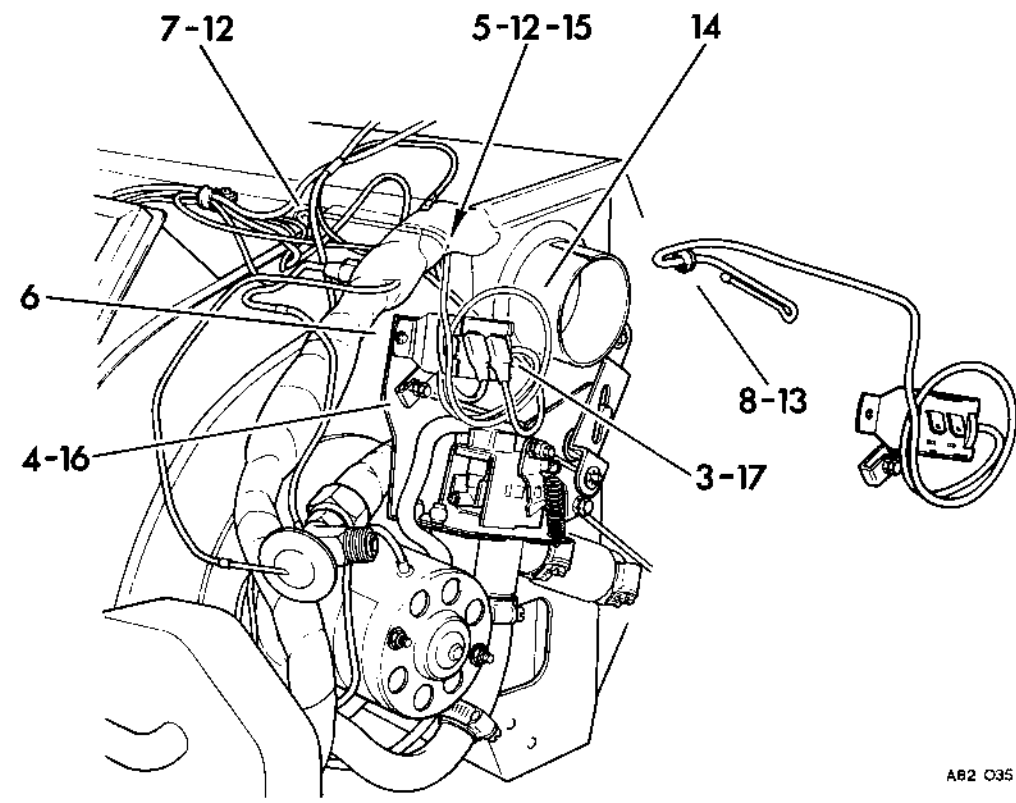

AB2 035

AB2 034/1

## CONTROLS

High pressure cut out –  
remove and refit 82.20.20

**CAUTION:** Immediate blanking of the receiver drier is important. Exposed life of the unit is only 15 minutes.

### Removing

- 1 Connect gauge set, see 82.30.01.
- 2 Discharge – complete system, see 82.30.05.
- 3 Protect the eyes with safety goggles and wear gloves during operation 4.
- 4 Carefully disconnect the capillary tube from the receiver drier. Blank exposed connections immediately.
- 5 Disconnect the multi-connector.
- 6 Remove two bolts and spring washers. Lift the high pressure cut out from the vehicle.

### Refitting

- 7 Position the high pressure cut out to the bracket. Secure with two bolts and spring washers.
- 8 Connect the multi-connector.
- 9 Carefully connect the capillary tube to the receiver drier. Use refrigerant compressor oil on all mating surfaces to assist leakage prevention.
- 10 Evacuate – complete system, see 82.30.06.
- 11 Charge – complete system, see 82.30.08.
- 12 Perform a leak test on any disturbed joints, see 82.30.09.
- 13 Functional check, see 82.30.16.
- 14 Disconnect gauge set, see 82.30.01.

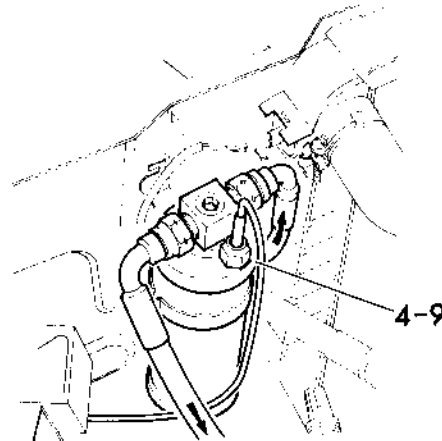
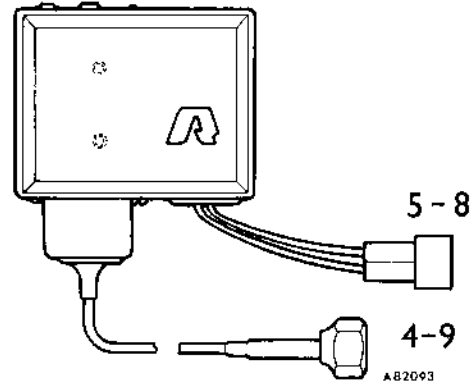

**CONTROLS**

Hot thermostat -- remove and refit 82.20.31

**Removing**

- 1 Isolate the battery.
- 2 Remove the fascia, see 76.46.01.
- 3 Drain the coolant, see 26.10.01.
- 4 Note the run of the capillary tube.
- 5 Cut the metal case between the screen outlet and grommet aperture. This will allow the capillary tube to be withdrawn sideways.
- 6 Hold the hot thermostat trunnion hexagon and slacken the screw. Detach the control rod.
- 7 Centre punch and drill out three rivets. Use a short  $\frac{1}{8}$  in drill and right angle drive to remove the forward two rivets. Use a  $\frac{1}{8}$  in drill from below to remove the rear rivet.
- 8 Slacken four hose clips.
- 9 Using a wide bladed screwdriver carefully prise the capillary tube loop from the four plastic clips securing it against the face of the hot matrix.
- 10 Carefully remove the hot thermostat from the vehicle. Maintain the shape of the capillary tube loop as a guide for the new unit.
- 11 Collect up the split rubber grommet.

**Refitting**

- 12 Bend the capillary tube of the new hot thermostat to the correct shape. Use the old unit as a guide.
- 13 Fit three spire nuts FJ 2544 to the mounting bracket.
- 14 Insert the capillary tube loop into position against the face of the hot matrix. Secure to the four plastic clips.
- 15 Manoeuvre the hot thermostat to position the two hose connections and achieve the capillary tube run noted at operation 4 above. Position the hot thermostat on the mounting bracket. Secure with three screws YZ 3404 and washers WP 0005.
- 16 Tighten four hose clips.
- 17 Attach the control rod. Adjust linkage B. see 82.25.08.
- 18 Fit the split rubber grommet.

- 19 Apply suitable sealer to the cut in the metal case.
- 20 Refill the coolant, see 26.10.01.
- 21 Fit the fascia, see 76.46.01.
- 22 Connect the battery.

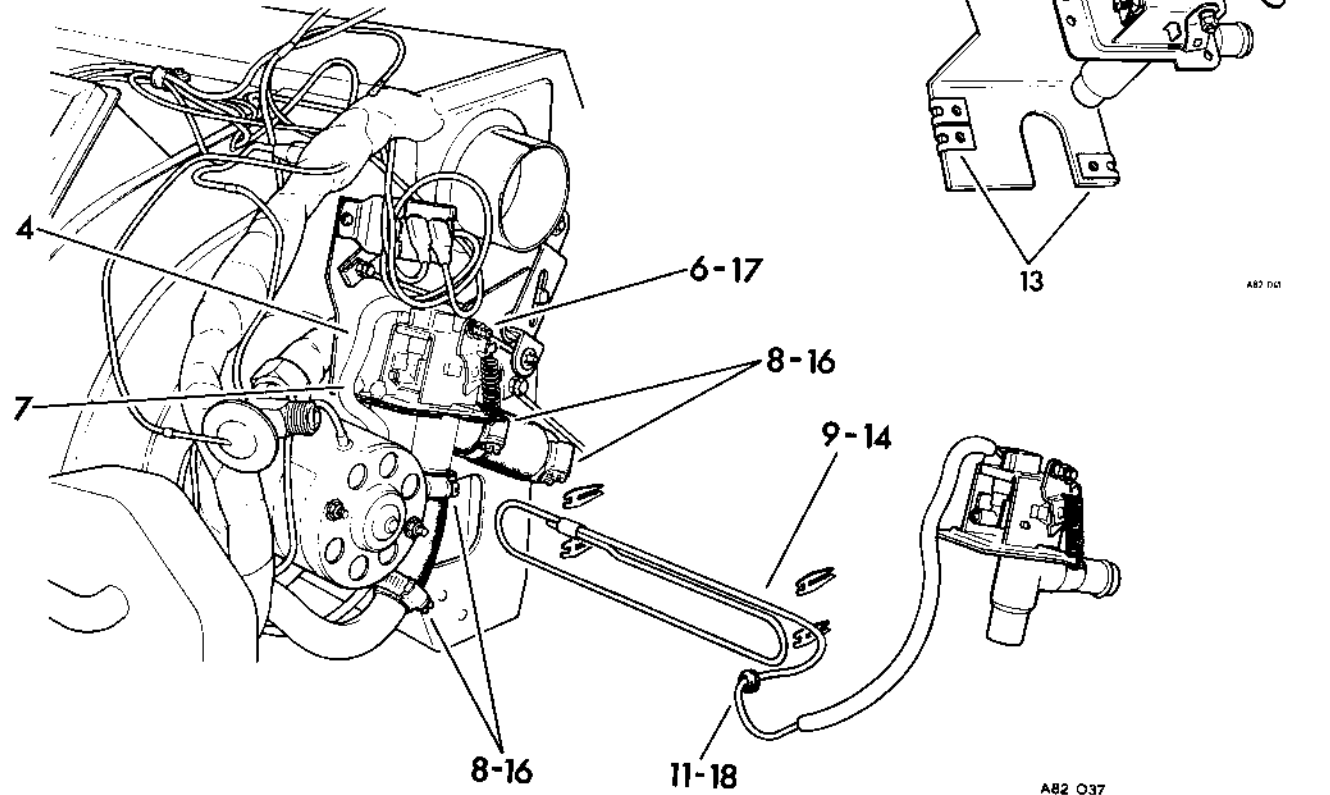

## CONTROLS

Throttle jack — remove and refit 82.20.36

The throttle jack is fitted to vehicles equipped with both air conditioning and automatic transmission.

### Removing

- 1 Disconnect two Lucar connectors.
- 2 Remove two bolts and lock washers.

### Refitting

- 3 Position the throttle jack. Secure with two bolts and lock washers.
- 4 Connect two Lucar connectors. The connectors may be fitted either way round.
- 5 Adjust the throttle jack, see 82.20.37.

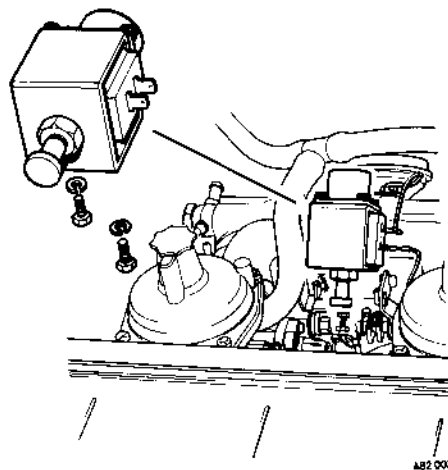

## CONTROLS

Throttle jack — adjust 82.20.37

The throttle jack is fitted to vehicles equipped with both air conditioning and automatic transmission.

- 1 Connect a tachometer to the engine as instructed by the manufacturer.

**NOTE:** The vehicle instrument panel tachometer may be used if no other instrument is available.

- 2 Run the engine.
- 3 Select lever C to 'OFF'.

**NOTE:** This action will switch out the air conditioning system. The compressor clutch will disengage removing the compressor drive load from the engine. The throttle jack plunger will be retracted.

- 4 The idle speed should now be 650 to 850 r.p.m. Nominal 750 r.p.m.
- 5 If a correction is required refer to Carburetters — tune and adjust, see 19.15.02.
- 6 Select lever C to any other position, 1, 2 or 3.

**NOTE:** This action will switch in the air conditioning system. The compressor clutch will engage applying the compressor drive load to the engine. The throttle jack plunger will be extended.

- 7 The idle speed should be maintained at 650 to 850 r.p.m. Nominal 750 r.p.m.
- 8 If a correction is required perform the following: Slacken the lock nut. Rotate the screw to adjust the idle speed. Tighten the lock nut.
- 9 Check that the correct idle speed has been maintained.

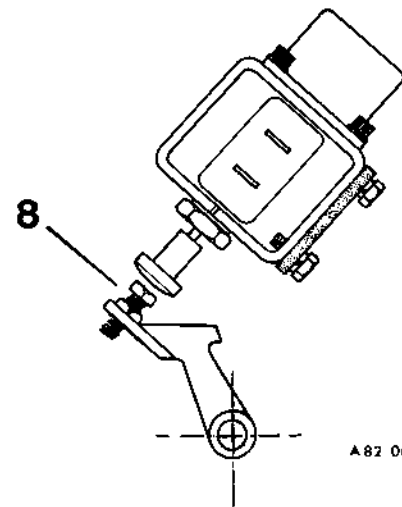

## AIR CONDITIONER UNIT

Description 82.25.00

The air conditioner unit is positioned on the centre line of the vehicle between the bulkhead and the fascia/centre console. The function of the unit is to receive air, process and deliver it to the outlets as directed by the control positions.

*Controls – to comprehend the system it should be appreciated that control lever 'A' positions flap 'A' via linkage 'A'. Similarly control lever 'B' operates linkage 'B'. Control lever 'C' positions flap 'C' via linkage 'C'. Finally control lever 'D' positions flap 'D' via linkage 'D'.*

**Intakes –** the system draws fresh air at ambient temperature through the fresh air duct, or recirculated air from the vehicle interior, into the blower motor intake. The choice is directed by control lever and flap C.

**Blower motor –** one blower motor which may be considered as an integral component of the air conditioner unit transfers air into the cold matrix.

**Cold matrix –** this unit is cooled by the cold refrigeration circuit. All airflow passes across the cold matrix to be conditioned. Cooling is achieved by heat being absorbed by the cold surfaces. Dehumidifying is achieved by moisture carried in the air condensing on the pipes of the cold matrix. Cleaning is achieved by the dust suspended in the air tending to be retained by the moisture. Water drains into a tray below the cold matrix. From the tray it escapes into the air inlet chamber via a short drain pipe. A second drain pipe runs vertically through the mounting rubber to the underside of the vehicle.

**Hot matrix –** this unit is heated by the hot water circuit. All airflow which is not permitted to escape cold through the three fascia vents is passed through the hot matrix to be heated.

- 1 Fresh air inlet
- 2 Recirculated air inlet
- 3 Screen outlet
- 4 Refrigerant inlet
- 5 Water inlet
- 6 Refrigerant outlet
- 7 Water outlet
- 8 Drain pipe
- 9 Drain pipe
- 10 Footwell outlet
- 11 Linkage D
- 12 Linkage C
- 13 Control levers
- 14 Central fascia vent outlet
- 15 End fascia vent outlet

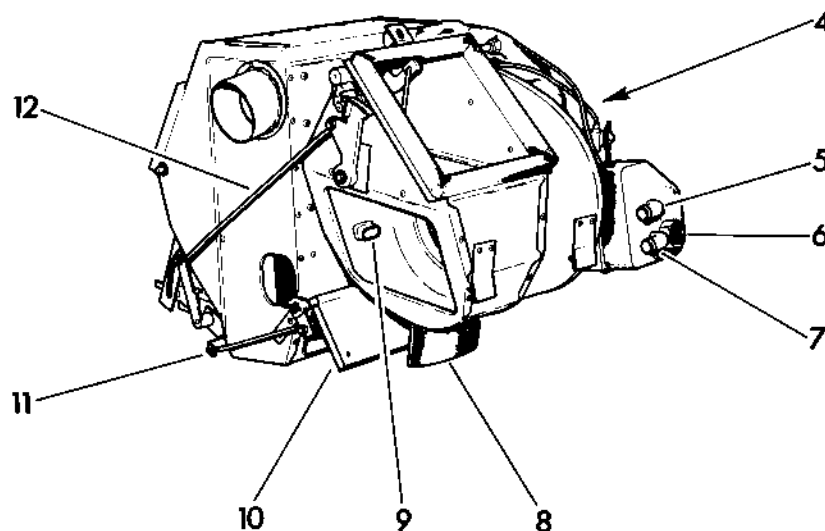
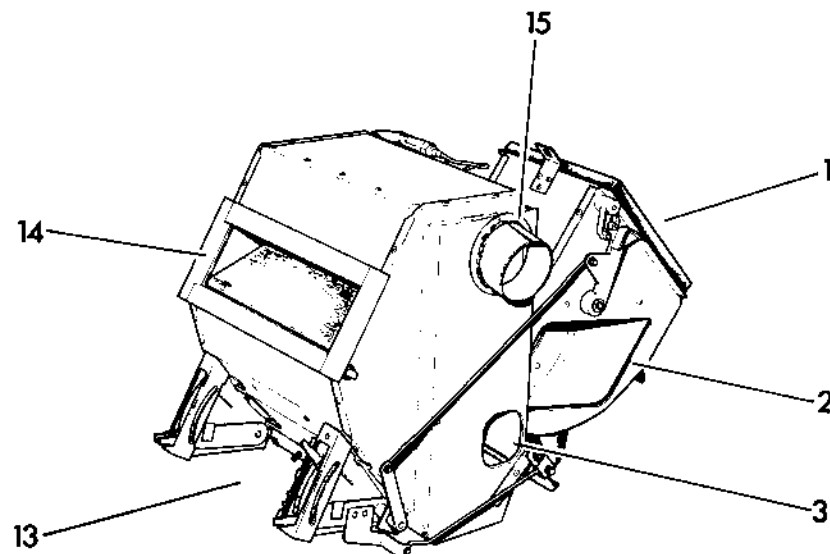

Fresh hot air to footwell

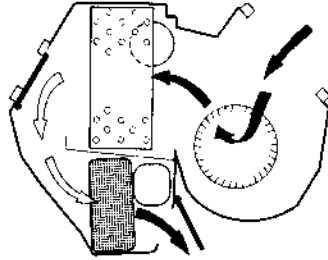
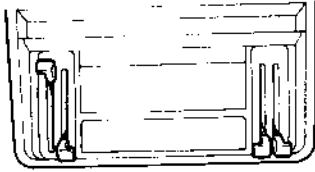

Recirculated hot air to screen

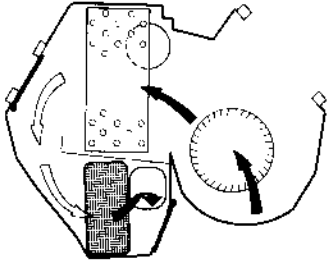
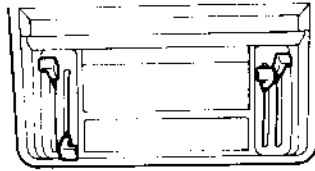

Fresh cold air to facia

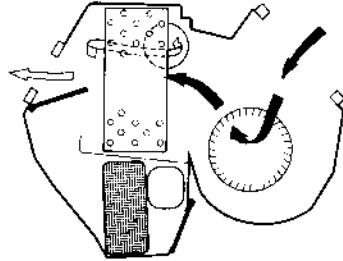

Recirculated cold air to facia

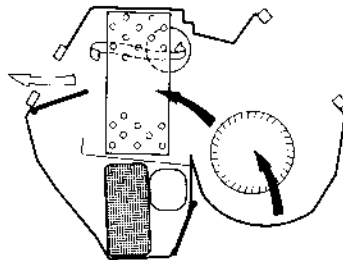

A82 024

A82 009

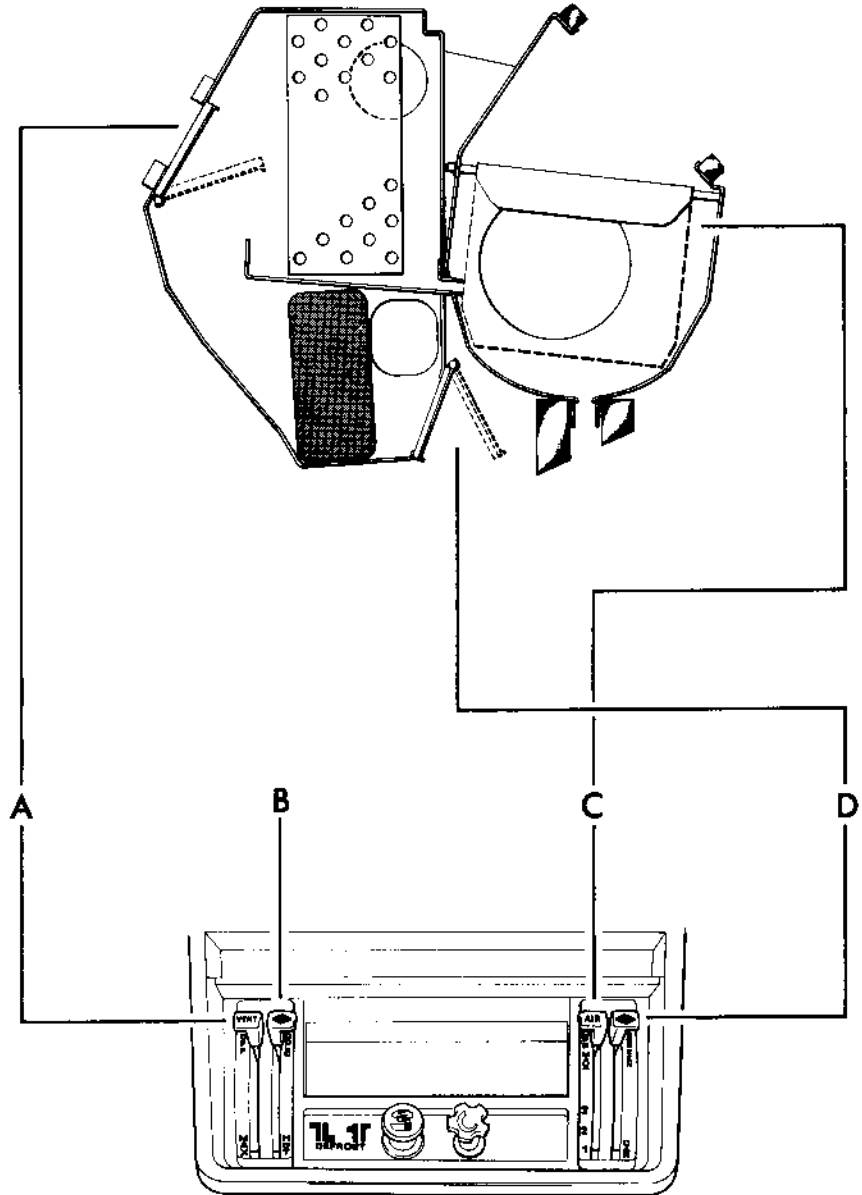

A82 017

**AIR CONDITIONER UNIT**

**Expansion valve — remove and refit** 82.25.01

**Removing**

- 1 Connect gauge set, see 82.30.01.
- 2 Discharge — complete system, see 82.30.05.
- 3 Isolate the battery.
- 4 Remove the fascia, see 76.46.01.
- 5 Note the run of the two capillary tubes.
- 6 Carefully cut and pull back the insulating material to expose the temperature capillary tube clamp and the pressure capillary tube union.
- 7 Slacken the clamp screw. Carefully withdraw the temperature capillary tube coil.
- 8 Carefully disconnect the pressure capillary tube union. Blank the exposed connections immediately.
- 9 Carefully disconnect the hose connection. Blank the exposed connections immediately.
- 10 Carefully disconnect the expansion valve mounting connection. Use two spanners at the joint to protect the delicate air conditioner unit pipe joint. Note that the larger rearward hexagon is the union to be rotated. Blank the exposed connections immediately.

**Refitting**

- 11 Apply refrigerant compressor oil to the mating surfaces of the three connections to assist leakage prevention.
- 12 Position the expansion valve with the run of the two capillary tubes as noted at operation 5 above. Carefully insert the temperature capillary tube coil in the clamp. Assemble the three connections finger tight.
- 13 Tighten the expansion valve mounting connection.
- 14 Tighten the hose connection.
- 15 Tighten the pressure capillary tube union.
- 16 Ensure that the temperature capillary tube coil is clean and in good contact with the refrigerant outlet pipe. Tighten the clamp screw.

- 17 Evacuate — complete system, see 82.30.06.
- 18 Connect the battery.
- 19 Charge — complete system, see 82.30.08.
- 20 Isolate the battery.
- 21 Perform a leak test on any disturbed joints, see 82.30.09.
- 22 Restore the insulating material. Ensure that the refrigerant outlet pipe is fully covered.
- 23 Fit the fascia, see 76.46.01.
- 24 Connect the battery.
- 25 Functional check, see 82.30.16.
- 26 Disconnect gauge set, see 82.30.01.

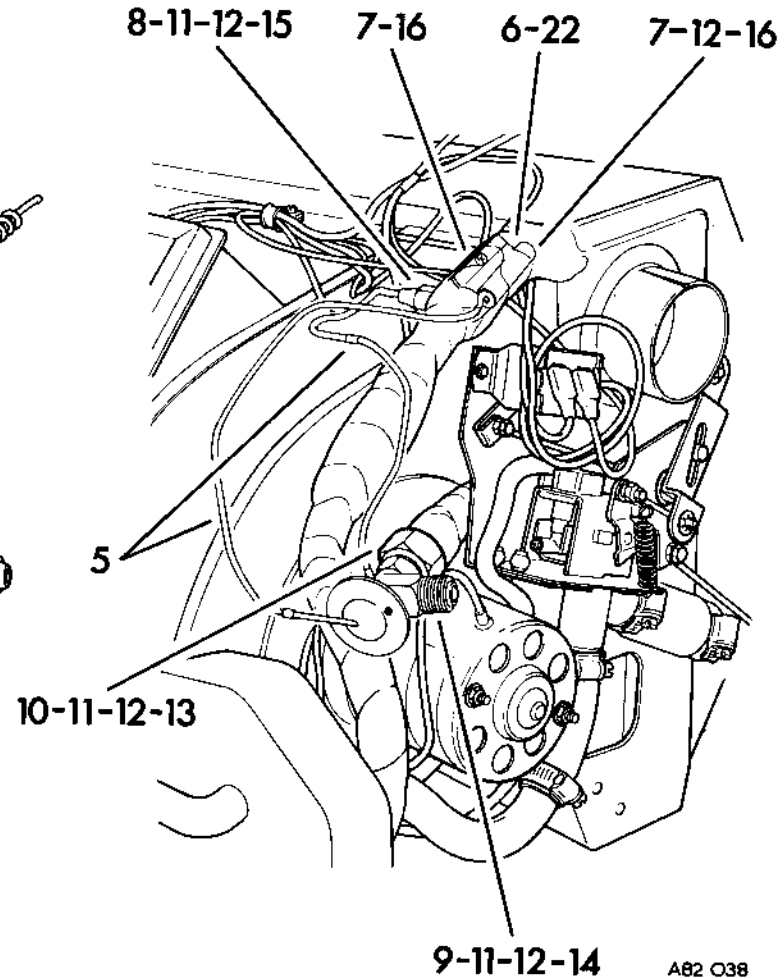
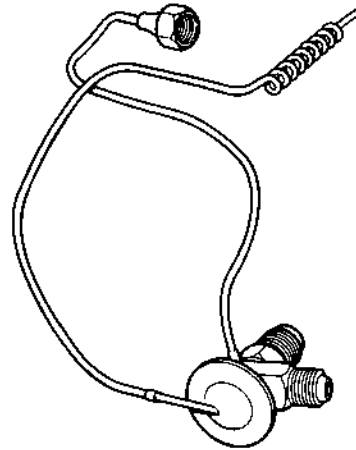



## AIR CONDITIONER UNIT

Linkages — adjust 82.25.08

### Linkage A

This is the linkage between control lever A and flap A.

- 1 Isolate the battery.
- 2 Remove the front console, see 76.25.01. This is necessary to obtain access to two screws.
- 3 Remove the control cowl, see 76.25.03.
- 4 Hold the trunnion hexagon and slacken the screw.
- 5 Position control lever A up to the OFF position.
- 6 Hold the flap arm in the close position. Tighten the screw.
- 7 Fit the control cowl, see 76.25.03.
- 8 Fit the front console, see 76.25.01.
- 9 Connect the battery.

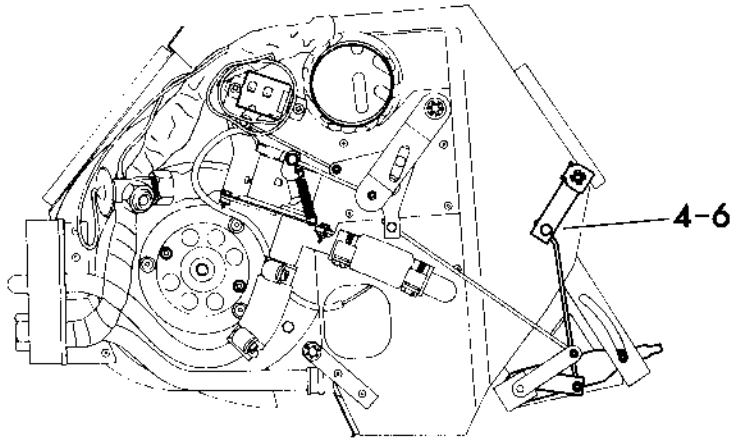

A82 025/1

### Linkage B

This is the linkage between control lever B to the cold thermostat and the hot thermostat.

- 10 Isolate the battery.
- 11 Remove the instrument panel, see 88.20.01.
- 12 Pull the facia end vent hose from the air conditioner unit outlet.
- 13 Hold the hot thermostat trunnion hexagon and slacken the screw.
- 14 Hold the cold thermostat trunnion hexagon and slacken the screw.
- 15 Hold the bell crank trunnion hexagon and slacken the screw.
- 16 Position control lever B up to the COLD position. Maintain in this position during operations 17 to 19.
- 17 Hold the bell crank so that the bell crank pin is positioned at the lower end of the swinging link slot. Tighten the screw.
- 18 Hold the cold thermostat input lever at its rearmost limit of travel. Tighten the screw.
- 19 Hold the hot thermostat input lever at its rearmost limit of travel with the forward projection against the metal stop. Tighten the screw.
- 20 Push the facia end vent hose onto the air conditioner unit outlet.
- 21 Fit the instrument panel, see 88.20.01.
- 22 Connect the battery.

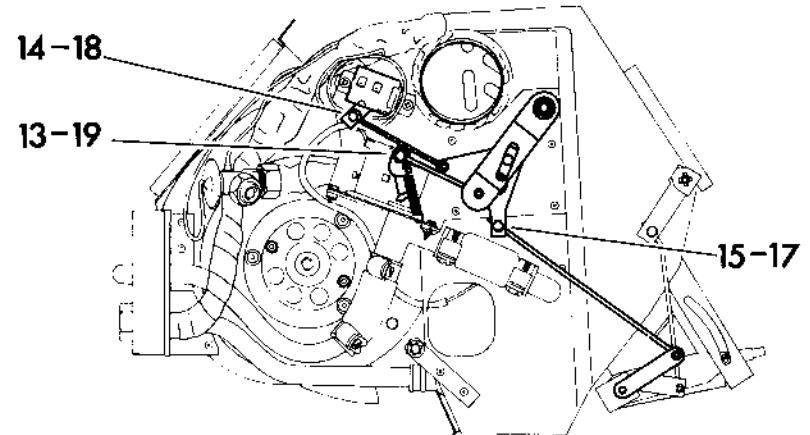

A82 026/1

**Linkage C**

This is the linkage between control lever C and the recirculate/fresh air flap C.

- 23 Isolate the battery.
- 24 Remove the facia, see 76.46.01.
- 25 Hold the trunnion hexagon and slacken the screw.
- 26 Position control lever C to the MAX position. This is one stop down from the full up position.
- 27 Hold the position of the 'quick changeover' lever to achieve the dimension shown. This is a nominal dimension of 2.75 mm from the lever reference face to the follower hole centre line. Tighten the screw.
- 28 Fit the facia, see 76.46.01.
- 29 Connect the battery.

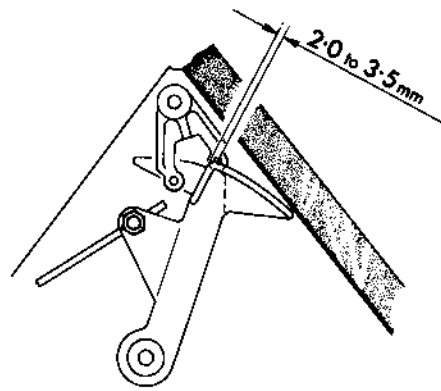

A82 C29

**Linkage D**

This is the linkage between control lever D and flap D.

- 30 Isolate the battery.
- 31 Remove the front console, see 76.25.01. This is necessary to obtain access to two screws.
- 32 Remove the control cowl, see 76.25.03.
- 33 Hold the trunnion hexagon and slacken the screw.
- 34 Position control lever D up to the SCREEN position.
- 35 Hold the flap arm in the close position. Tighten the screw.
- 36 Fit the control cowl, see 76.25.03.
- 37 Fit the front console, see 76.25.01.
- 38 Connect the battery.

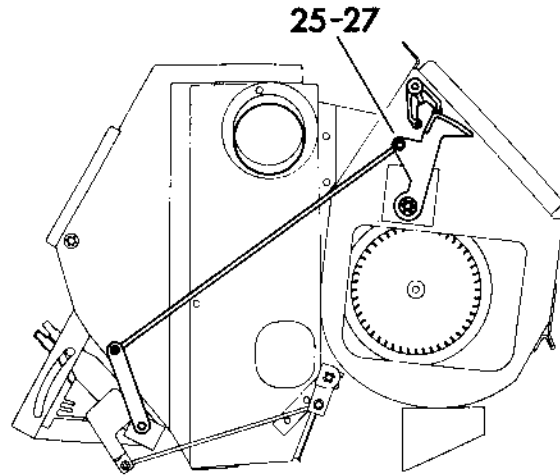

A82 D2/h

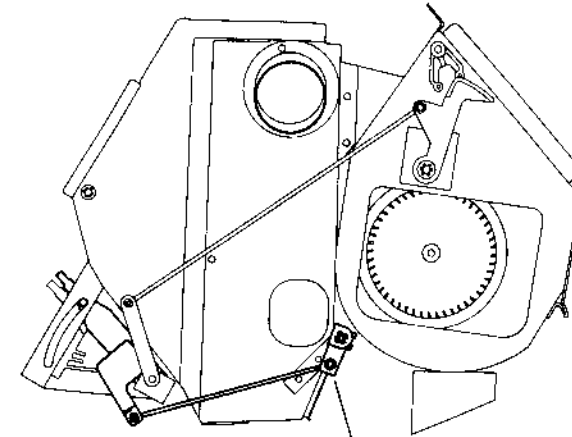

33-35

A82 D22/h

## SERVICING

### WARNING:

The refrigeration circuit must only be disturbed by a qualified refrigeration engineer possessing the required special servicing equipment. Failure to observe this instruction may result in severe personal injury.

When discharging or subsequently breaking open any pipe connections, protect the eyes with safety goggles and wear gloves.

If any liquid refrigerant should contact the eyes, splash with cold water to slowly raise the temperature. Mineral or cod liver oil on the area will reduce the chance of infection. Consult an eye specialist as soon as possible.

Ensure that no refrigerant vapour comes into contact with an open flame. Should this occur a poisonous, corrosive gas may be produced. This vapour may attack metal.

Refrigerant in containers must be protected from heat. Do not expose to radiant heat from the sun. Do not place in water above 50° C (122° F). Do not heat with any flame. Do not carry a container in the vehicle interior.

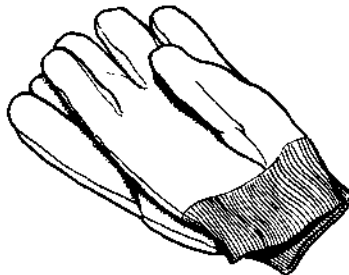
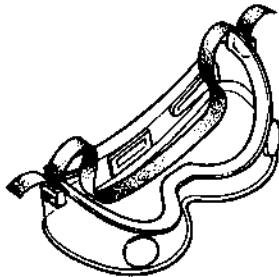

A82 046

### Data

#### Refrigerant

82.30.00

Type .....	Refrigerant 12
Approved trade names .....	Arcton 12
	Freon 12
	Isceon 12

Properties at normal atmospheric pressure and temperature .....	Vapour
	Odourless
	Colourless
	Heavier than air
	Non-corrosive
	Non-explosive
	Non-inflammable
	Non-poisonous

#### Dangerous at normal atmospheric pressure and temperature

- contact with the skin ..... Liquid refrigerant will freeze anything it contacts. Severe burns may result. Especially dangerous to the eyes. Always protect with safety goggles.
- contact with an open flame .... A poisonous, corrosive gas may be produced. This vapour may attack metal.

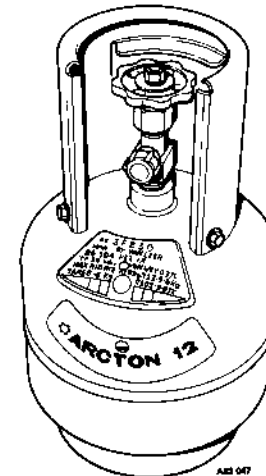

A82 047

**Description 82.30.00**

Servicing equipment must include a suitable gauge set or service trolley. Other tools are shown below.

When it is necessary to 'break into' the refrigeration circuit the system must first be discharged.

Either the complete system or the compressor only may be discharged. The choice will depend on the operation to be undertaken. When the compressor only is discharged the remainder of the system stays charged and undisturbed. A saving of refrigerant is also achieved.

To prevent icing or corrosion inside the refrigeration system extreme precautions must be observed during servicing to exclude moisture. Component connections and hose ends must only be open to atmosphere for a brief period. Blanking caps must be fitted immediately to any exposed connections. Replacement components will be supplied sealed and must only be opened immediately prior to making the connections.

The system should then be immediately charged with fresh refrigerant.

Refrigerant may be provided from single cans, from a multi-can manifold or from a service trolley container. The container should be replenished from a heavy bottle.

A method of calculating the weight of refrigerant introduced into the system is required. This may be by a spring balance or a service trolley container with a graduated scale.

After assembly the system must be evacuated. This should remove air, moisture and old refrigerant from the system.

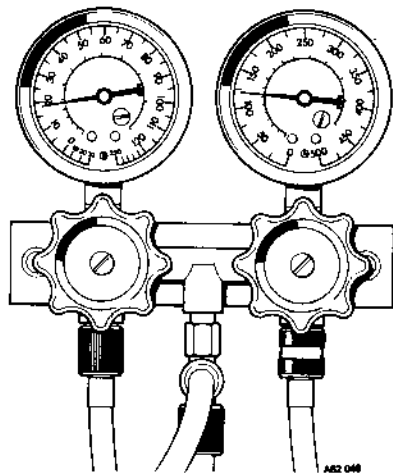

Gauge set

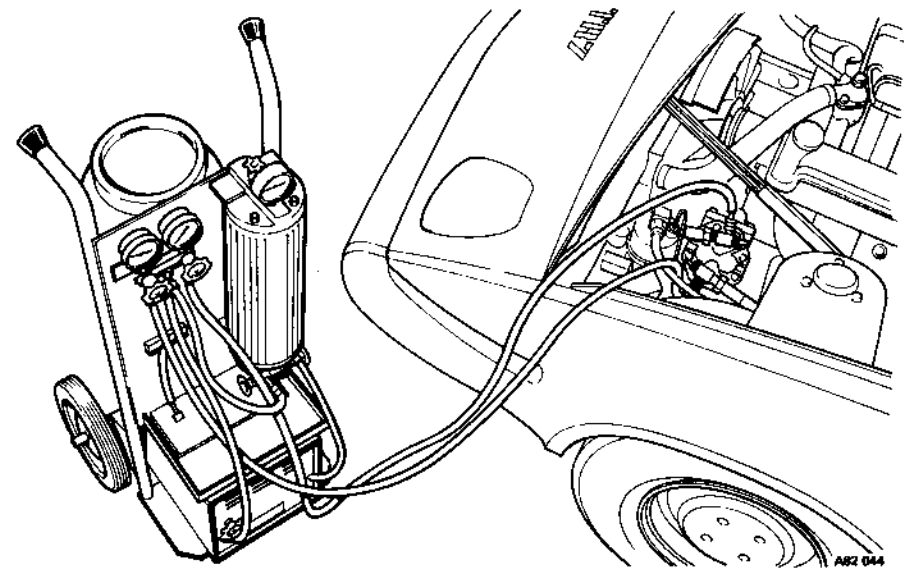

Service trolley

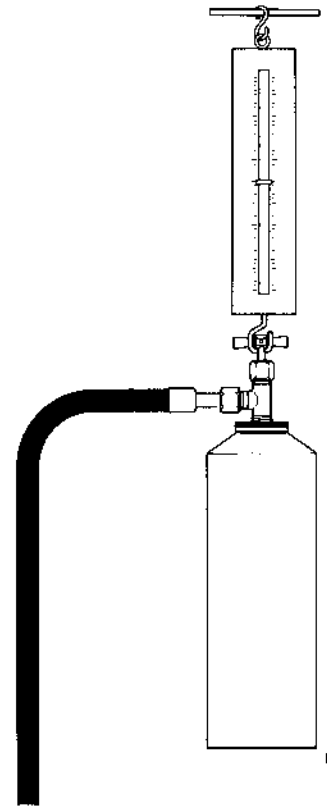

Single can on spring balance

M124

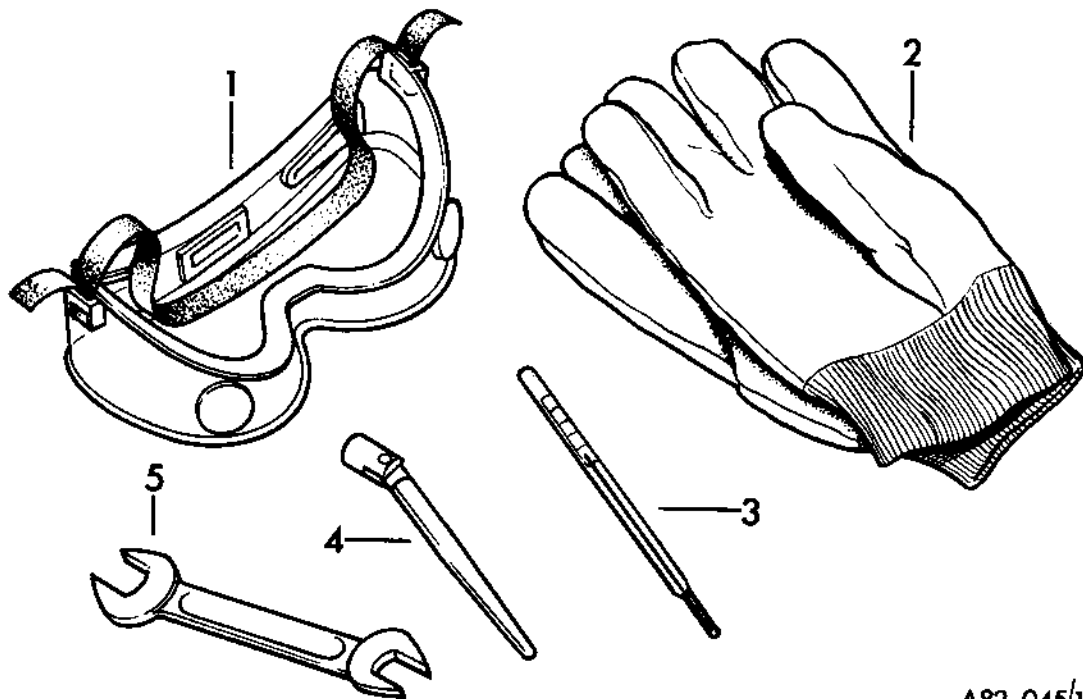

- 1 Goggles
- 2 Gloves
- 3 Thermometer
- 4 Square 1/4 AF tool to fit service valve stem.

**NOTE:** Girling brake adjuster spanner – Girling Part No. 64947051 – is ideal for this operation.

- 5 Spanner 3/8 AF to fit service valve hexagon cap.

A82 045/1

### Service valves

Refrigerant is introduced and removed from the refrigeration circuit by way of two service valves located on the compressor top plate.

One service valve communicates with the input side of the compressor and is designated the 'SUCTION' or low side service valve. The other service valve is associated with the compressor output side and is designated the 'DISCHARGE' or high side service valve.

The service valves are controlled by square ended shafts normally covered by protective covers.

Each service valve has three basic positions summarized as follows:

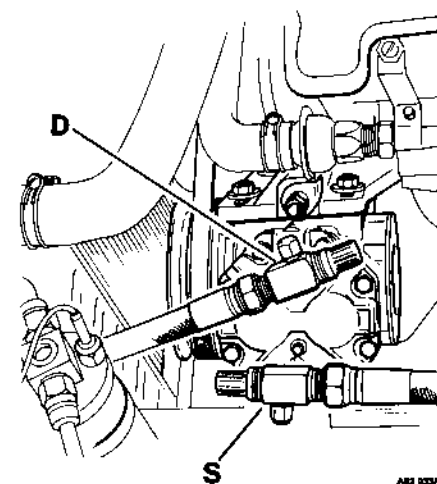

- D Discharge valve
- S Suction valve

A82 0236

### SERVICE VALVE POSITIONS

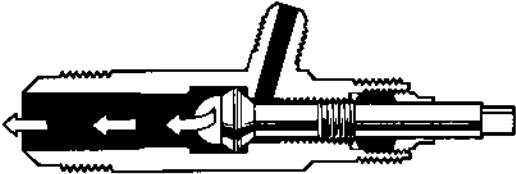
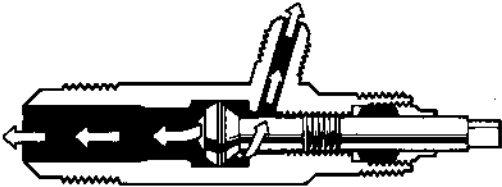
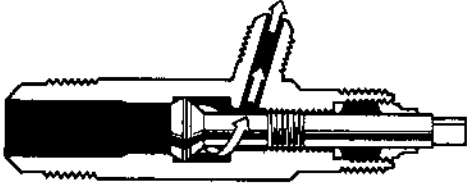
<p>Back seat position</p>	<p>Turn full anti-clockwise</p>	<p>Normal system operating position</p> <p>Compressor communicating with refrigeration circuit</p> <p>Service port sealed</p>	
<p>Mid position</p>	<p>From back seat position turn clockwise 3 turns</p>	<p>Compressor and refrigeration circuit communicating with service port</p>	
<p>Front seat position</p>	<p>Turn full clockwise</p>	<p>Compressor communicating with service port</p> <p>Refrigeration circuit sealed</p>	 <p style="text-align: right;">MOB4</p>

## SERVICING

### Gauge set—connect 82.30.01

- 1 Position the vehicle in a suitable area. This should be:
  - a Well ventilated for the discharge of refrigerant.
  - b Away from any naked flame.
  - c Suitable for an engine run.
- 2 Provide a suitable gauge set or service trolley.
- 3 Close all gauge set or service trolley valves.

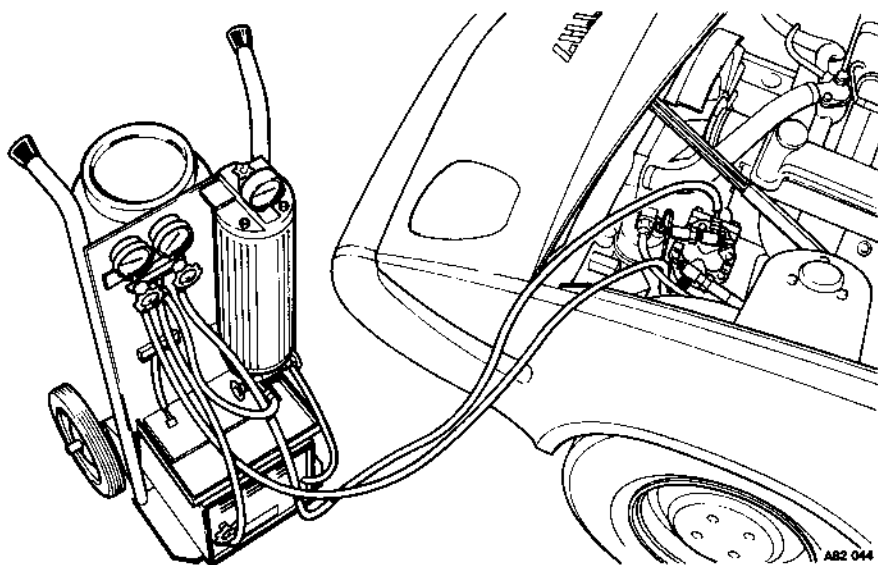
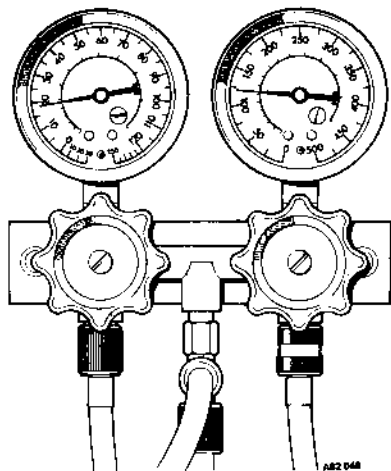

- 4 Remove the two service valve protective covers.
- 5 Ensure that both service valves are in the back seat position – turn anti-clockwise.
- 6 Remove the two hexagon caps.
- 7 Connect the gauge set discharge hose to the discharge service valve.
- 8 Connect the gauge set suction hose to the suction service valve.

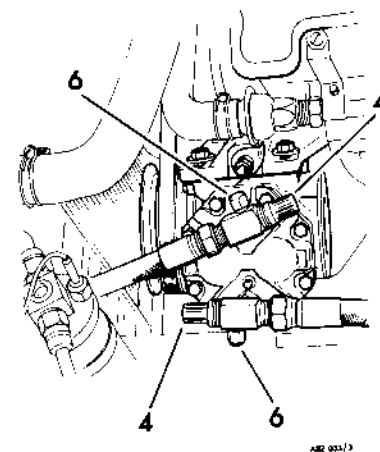

- 9 Purge the air from the two gauge set hoses as follows:
  - a Provide a supply of refrigerant to the gauge set centre manifold hose.

**NOTE:** This may be from a single can, from a multi-can manifold or from a service trolley container.

- b Protect the eyes with safety goggles and wear gloves during operations c and d.
- c Loosen the gauge set hose connection to the discharge service valve. Carefully open the gauge set discharge valve. When refrigerant is seen to be escaping tighten the hose connection. Close the gauge set discharge valve.
- d Loosen the gauge set hose connection to the suction service valve. Carefully open the gauge set suction valve. When refrigerant is seen to be escaping tighten the hose connection. Close the gauge set suction valve.

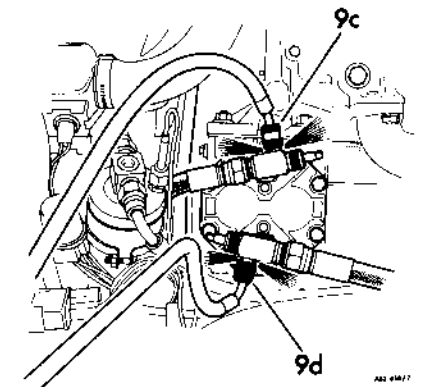
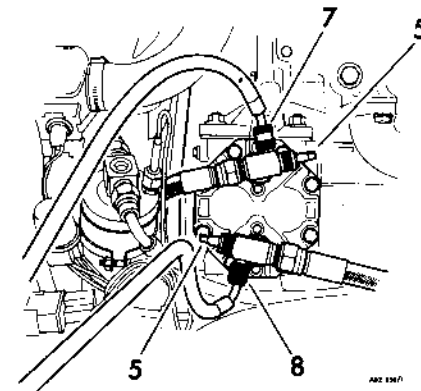

## SERVICING

## Gauge set — disconnect 82.30.01

- 10 Close all gauge set or service trolley valves.
- 11 Ensure that both service valves are in the back seat position — turn anti-clockwise.
- 12 Protect the eyes with safety goggles and wear gloves during operation 13.
- 13 Disconnect both gauge set hoses from the service valves.
- 14 Fit the two hexagon caps.
- 15 Fit the two service valve protective covers.

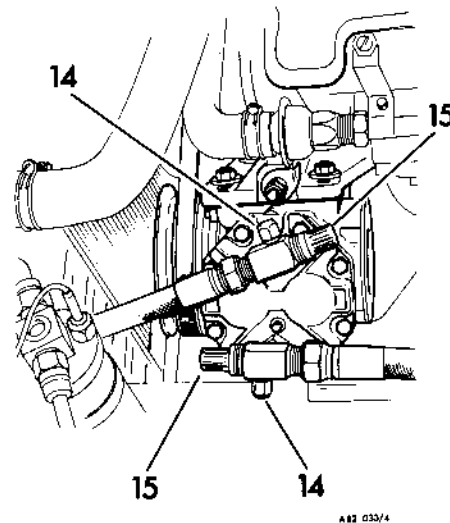
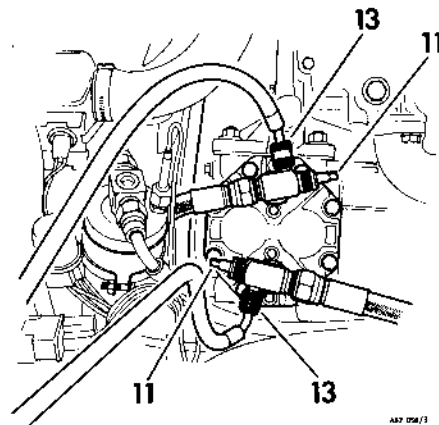

## SERVICING

## Discharge — complete system 82.30.05

- 1 Connect gauge set, see 82.30.01.
- 2 Immobilize the refrigerant circuit by disconnecting the electrical connection to the compressor clutch.
- 3 Open the discharge service valve to mid-position — turn clockwise three turns.
- 4 Open the suction service valve to mid-position — turn clockwise three turns.
- 5 Protect the eyes with safety goggles and wear gloves during operations 6 to 8.
- 6 Hold the gauge set centre manifold hose end in a suitable rag.
- 7 Slightly open the gauge set discharge valve to allow the refrigerant vapour to slowly discharge to atmosphere via the hose end. If oil from the compressor is discharged, reduce the gauge set discharge valve opening.

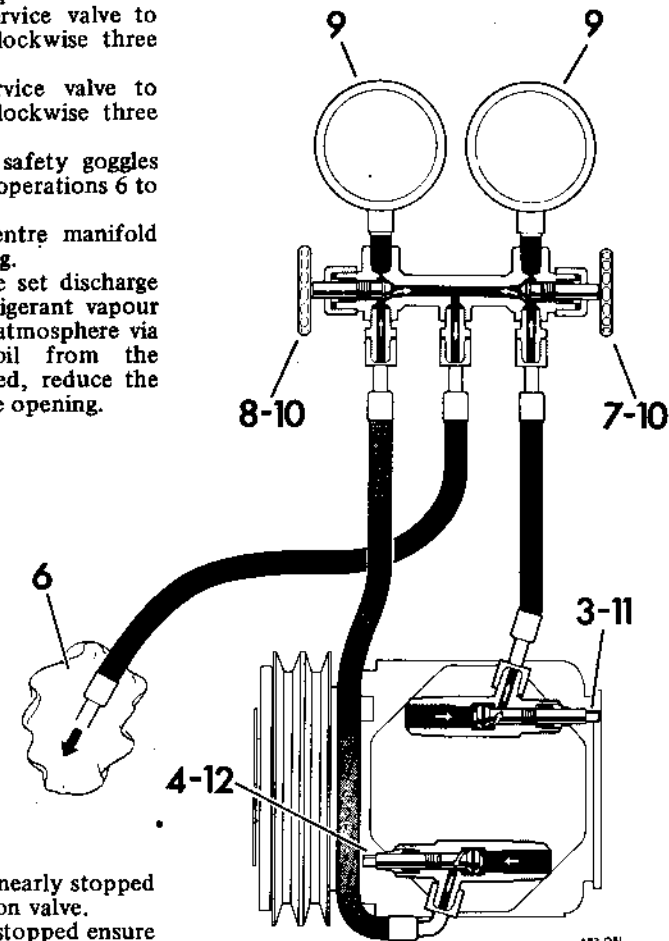

- 8 When the discharge has nearly stopped open the gauge set suction valve.
- 9 When the discharge has stopped ensure that both gauges read zero.
- 10 Close both gauge set valves.
- 11 Close the discharge service valve to the back seat position — turn anti-clockwise.
- 12 Close the suction service valve to the back seat position — turn anti-clockwise.



## SERVICING

### Evacuate — complete system 82.30.06

- 1 Connect gauge set, 82.30.01.
- 2 Discharge — complete system, see 82.30.05.
- 3 Connect a vacuum pump to the gauge set centre manifold hose.
- 4 Open the discharge service valve to mid-position — turn clockwise three turns.
- 5 Open the suction service valve to mid-position — turn clockwise three turns.
- 6 Open both gauge set valves fully.

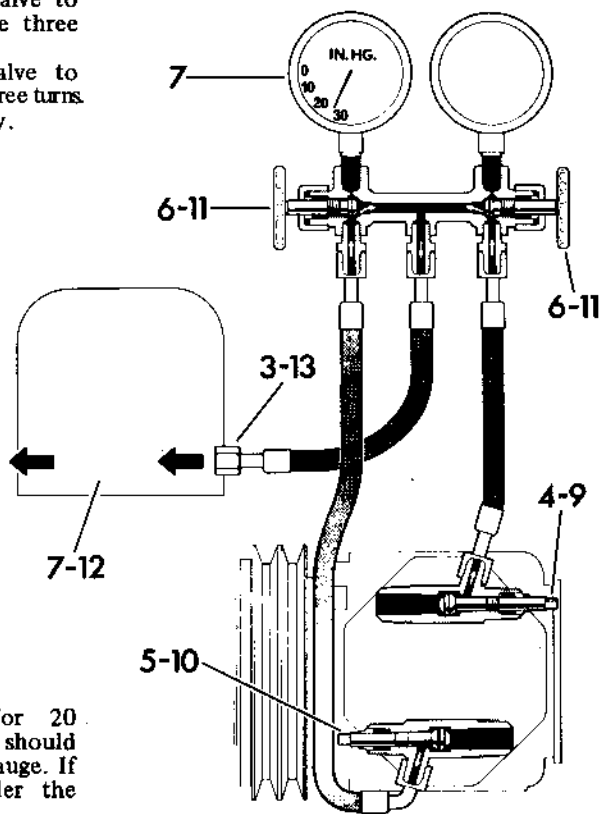

- 7 Run the vacuum pump for 20 minutes. A vacuum of 28 in Hg should be indicated on the suction gauge. If this is not achieved, consider the possibility of a system leak.
- 8 Perform operations 9 to 11 with the vacuum pump running.
- 9 Close the discharge service valve to the back seat position — turn anti-clockwise.
- 10 Close the suction service valve to the back seat position — turn anti-clockwise.
- 11 Close both gauge set valves.
- 12 Stop the vacuum pump.
- 13 Disconnect the vacuum pump from the gauge set centre manifold hose.

## SERVICING

### Charge — complete system 82.30.08

**CAUTION:** Charge with refrigerant 12 of approved trade names:

Arcton 12  
Freon 12  
Isceon 12

**Do not charge with methylchloride refrigerant. This would react undesirably with aluminium parts used in the system.**

- 1 Connect gauge set, see 82.30.01.
- 2 Discharge — complete system, see 82.30.05.
- 3 Evacuate — complete system, see 82.30.06
- 4 Provide a supply of refrigerant to the gauge set centre manifold hose.

**NOTE:** This may be from single cans, from a multi-can manifold or from a service trolley container.

- 5 If the centre manifold hose contains air purge with refrigerant as follows:
  - a Protect the eyes with safety goggles and wear gloves during operation b.
  - b Carefully loosen the gauge set centre manifold hose connection. When refrigerant is seen to be escaping tighten the hose connection.

*continued*

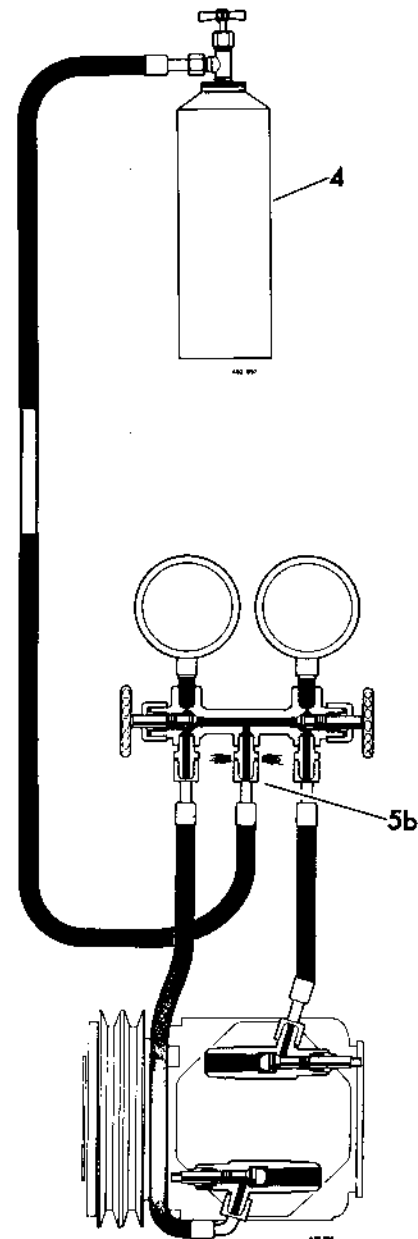

- 6 Provide a method of calculating at any time during the operation, the weight of refrigerant put into the system.

**NOTE:** A single can or a multi-can manifold may be weighed by hanging from a spring balance. A service trolley container should have a graduated scale.

- 7 Note the datum refrigerant weight.  
8 Open the suction service valve to mid-position – turn clockwise three turns.  
9 Slightly open the gauge set suction valve. Allow approximately ½ lb (230 g) of refrigerant to enter the system. Close the gauge set suction valve.

**NOTE:** High pressure liquid refrigerant from the container will vaporize on entering the evacuated low pressure system. Flow will continue until container pressure equals system pressure or until the gauge set suction valve is closed.

- 10 Perform a first leak test on any disturbed joints, see 82.30.09.  
11 Slightly open the gauge set suction valve. If the pressure differential between the container and the system permits allow the flow to continue until a total of 2½ lb (1130 g) of refrigerant – from the datum weight operation 7 – has entered the system. Close the gauge set suction valve.

**NOTE:** High pressure liquid refrigerant from the container will vaporize on entering the evacuated low pressure system. Flow will continue until container pressure equals system pressure or until the gauge set suction valve is closed.

- 12 If a total of 2½ lb (1130 g) of refrigerant is in the system perform the following:

- a Close the suction service valve to the back seat position – turn anti-clockwise.  
b Ignore operations 13 to 19.

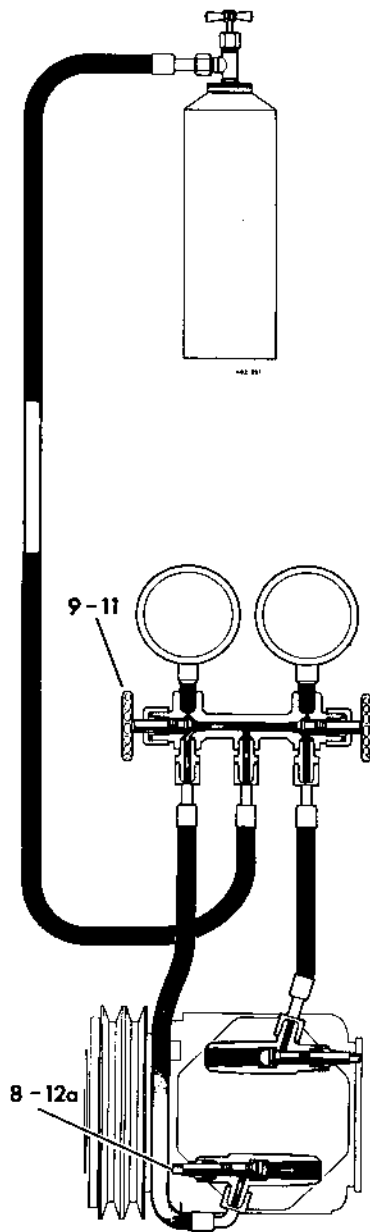

- 13 If the container pressure and the system pressure equalize before a total of 2½ lb (1130 g) of refrigerant is in the system perform operations 14 to 19.  
14 Ensure that the gauge set suction valve is closed.  
15 Connect the electrical connection to the compressor clutch.  
16 Run the engine at 1000 to 1500 rev/min for 5 minutes with the control levers set as follows:

Lever A to MAX.  
Lever B to COLD  
Lever C to 3  
Lever D to CAR

This is to warm the engine and stabilize the system.

**NOTE:** Warm air from above the engine will enter the fresh air duct to be presented to the cold matrix. This condition will cause the system to operate hard and prevent frequent cutting in and out of the compressor clutch.

- 17 Slightly open the gauge set suction valve. Allow the flow to continue until a total of 2½ lb (1130 g) of refrigerant – from the datum weight operation 7 – has entered the system. Close the gauge set suction valve.

**NOTE:** Compressor suction will draw further vaporized refrigerant into the system. The refrigeration circuit will commence to function and vapour passed into the condenser will accumulate as liquid refrigerant in the receiver drier.

- 18 Close the suction service valve to the back seat position – turn anti-clockwise.  
19 Stop the engine.

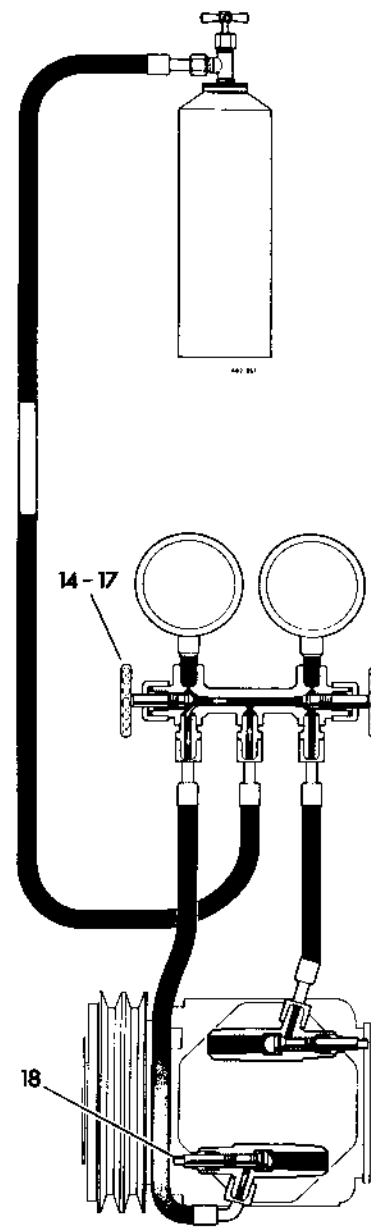

## SERVICING

### Leak test

82.30.09

A major leak in the system should be shown up during the evacuate operation prior to charging with fresh refrigerant.

Minor leaks should be searched for as instructed in the charge operation using one of the two basic types of leak testing equipment in common use.

The burner type has a hand held burner connected by hose to a cylinder of gas. A second hose attached to the burner is the search hose which draws in air or refrigerant vapour. This hose is of some length so its end may be positioned close to the unions while the burner is held and observed by a second operator a safe distance from the vehicle. A leak is indicated by the flame changing colour to green or purple. The product of burning gas and refrigerant is a poisonous, corrosive gas which should not be inhaled.

The electronic type may be semi portable with mains electric power or fully portable with batteries. The sensors are sensitive to refrigerant vapour. The sensor may be positioned at the end of a search cable or the air sample may be drawn through a search hose by a small electric air pump to be passed across a sensor in the unit. The sensor signal is amplified. A leak is indicated by audible warning, a light signal or meter reading.

Whether a burner type or electronic type unit is used the equipment should be employed as detailed by the manufacturer. The following instructions are provided to assist leak testing.

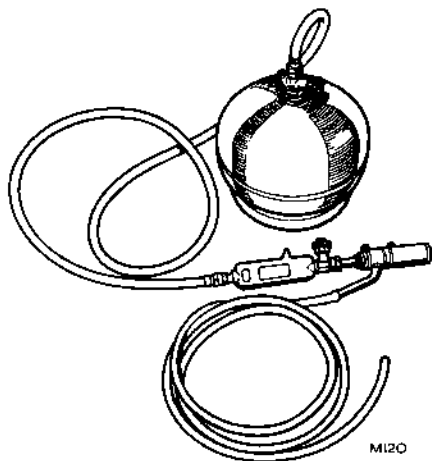

Typical electronic leak tester

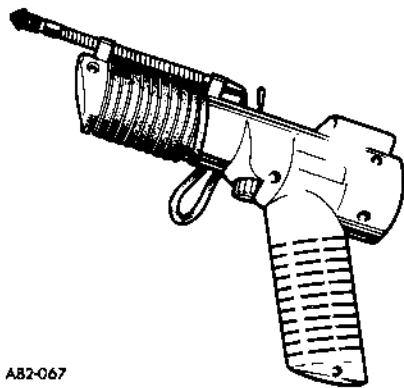

Typical burner leak tester

### General

Place the vehicle in a well ventilated area or refrigerant may persist in the vicinity and give misleading results.

Strong draughts should be avoided as a leak may be dissipated without detection.

Refrigerant is heavier than air. When checking each union pass the detector slowly round each joint with special attention to the underside.

### Compressor

Check two hose connections, service valves, head joint, rear bearing plate joint and base joint.

Check the shaft seal by positioning the detector between the clutch and seal plate. As access is poor, leave the detector in the vicinity for one minute.

### Condenser

Check two hose connections. Check all soldered joints and pass detector across underside of unit.

### Receiver drier

Check two hose connections and high pressure cut-out capillary.

### Expansion valve and air conditioner unit pipes

Check all accessible pipes and joints. If a known leak can not be located it may finally be necessary to perform the following:

Remove the fascia. Carefully cut and pull back the insulating material to expose the pipe runs. After the leak test restore the insulating material. Ensure that the refrigerant outlet pipe is fully covered.

### Cold matrix

Select lever 'A' to MAX. Insert the probe through the central fascia vent.

Select lever 'D' to CAR. Insert the probe into the footwell outlet.

Check below the matrix by positioning the probe into the recirculated air inlet and checking near the drain pipe (see 82.25.00, Item 9).

## SERVICING

## Functional check 82.30.16

- 1 Ensure that the compressor drive belt is correctly adjusted, see 82.10.01.
- 2 Connect gauge set, see 82.30.01.
- 3 Open the discharge service valve towards mid-position – turn clockwise half a turn.
- 4 Open the suction service valve forwards mid-position – turn clockwise half a turn.
- 5 Note the ambient air temperature.
- 6 Run the engine at 1000 to 1500 rev/min for 5 minutes with the control levers set as follows:  
Lever A to MAX.  
Lever B to COLD

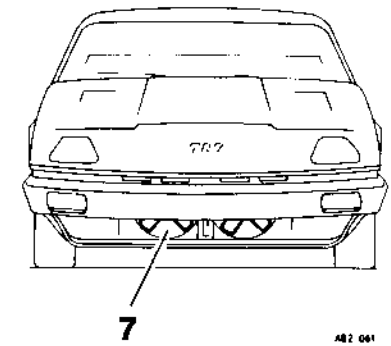
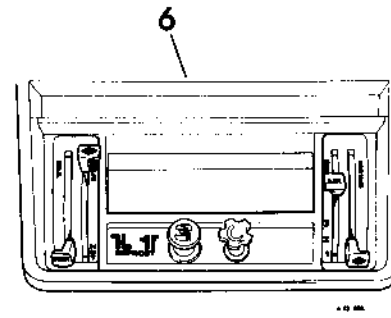
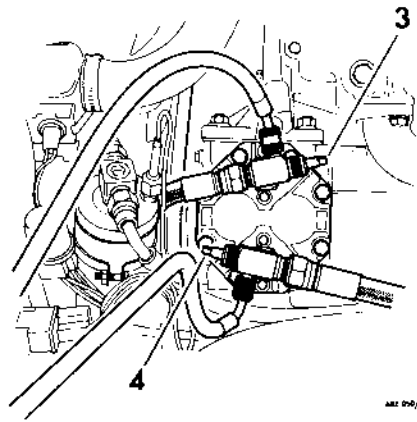

**NOTE:** In humid conditions it may be necessary to reduce lever 'B' setting from full 'COLD' towards 'HOT' to prevent icing of the cold matrix. Slightly higher central fascia vent air temperatures should then be expected.

Lever C to MAX.  
Lever D to CAR

This is to warm the engine and stabilize the system.

- 7 Check that the two condenser fan motors run when the compressor clutch pulls in and stop when the compressor clutch drops out.
- 8 Check that the receiver drier sight glass is clear of bubbles or foam.
- 9 Note the maximum discharge gauge reading when the compressor clutch is pulled in.
- 10 Note the minimum suction gauge reading when the compressor clutch is pulled in.
- 11 Insert a thermometer into the central fascia vent and note the minimum temperature.
- 12 Stop the engine.
- 13 Compare all readings with the values given in the table.
- 14 Close the discharge service valve to the back seat position – turn anti-clockwise.
- 15 Close the suction service valve to the back seat position – turn anti-clockwise.
- 16 Disconnect gauge set, see 82.30.01.

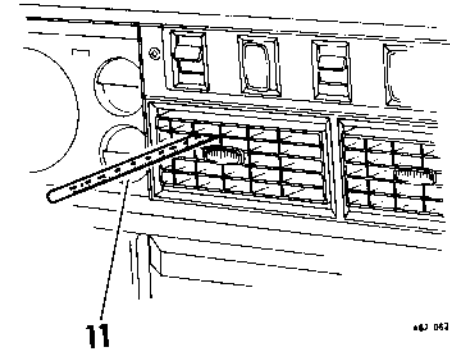
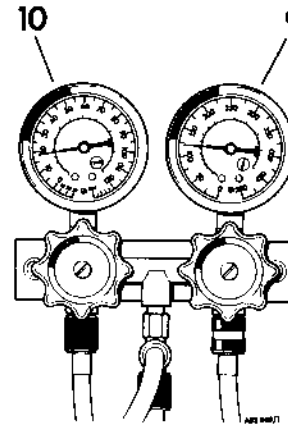
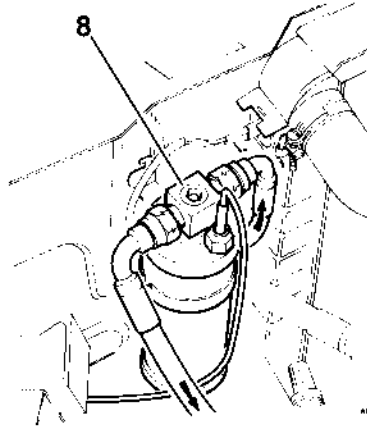

Ambient air temperature		Discharge gauge – maximum		Suction gauge – minimum		Central fascia vent temperature – minimum	
°F	°C	psi	kg/cm <sup>2</sup>	psi	kg/cm <sup>2</sup>	°F	°C
60	16	12 to 20	0.8 to 1.4	80 to 130	5.6 to 9.1	32 to 40	0 to 4
80	27	16 to 25	1.1 to 1.8	130 to 180	9.1 to 12.7	35 to 44	2 to 7
100	38	18 to 28	1.3 to 2.0	200 to 240	14.1 to 16.9	38 to 47	3 to 8
110	43	19 to 29	1.3 to 2.0	240 to 275	16.9 to 19.3	39 to 48	4 to 9

The above figures are not specific to the TR7 installation. All readings obtained should be approximately equal to the values given in the table.

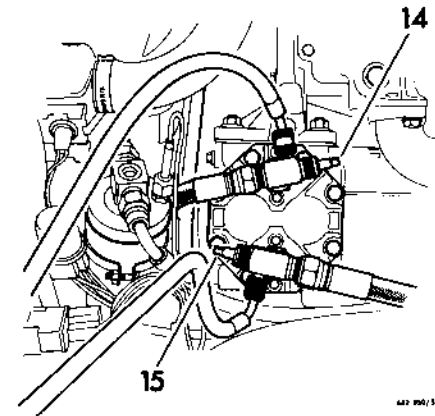

## SERVICING

### Discharge – compressor only 82.30.20

- 1 Connect gauge set, see 82.30.01.
- 2 Immobilize the refrigerant circuit by disconnecting the electrical connection to the compressor clutch.
- 3 Close the discharge service valve to the front seat position – turn clockwise.
- 4 Close the suction service valve to the front seat position – turn clockwise.
- 5 Protect the eyes with safety goggles and wear gloves during operations 6 to 8.
- 6 Hold the gauge set centre manifold hose end in a suitable rag.
- 7 Slightly open the gauge set discharge valve to allow the refrigerant vapour to slowly discharge to atmosphere via the hose end. If oil from the compressor is discharged, reduce the gauge set discharge valve opening.
- 8 When the discharge has nearly stopped open the gauge set suction valve.
- 9 When the discharge has stopped ensure that both gauges read zero.
- 10 Close both gauge set valves.

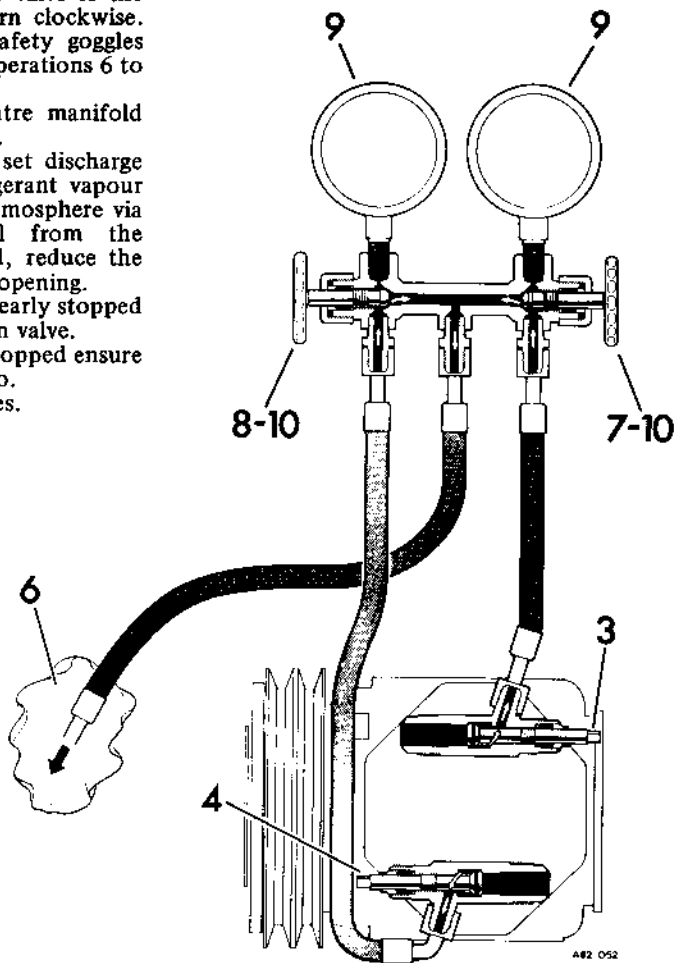

## SERVICING

### Evacuate – compressor only 82.30.21

- 1 Connect gauge set, see 82.30.01.
- 2 Discharge – compressor only, see 82.30.20.
- 3 Connect a vacuum pump to the gauge set centre manifold hose.
- 4 Open both gauge set valves fully.

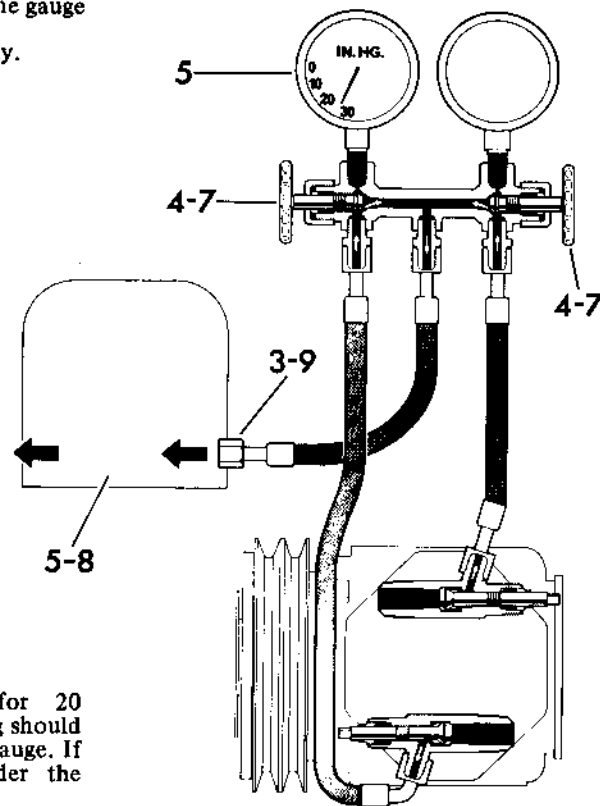

- 5 Run the vacuum pump for 20 minutes. A vacuum of 28 in Hg should be indicated on the suction gauge. If this is not achieved, consider the possibility of a system leak.
- 6 Perform operation 7 with the vacuum pump running.
- 7 Close both gauge set valves.
- 8 Stop the vacuum pump.
- 9 Disconnect the vacuum pump from the gauge set centre manifold hose.

**SERVICING**

Charge — compressor only 82.30.23

**CAUTION:** Charge with refrigerant 12 of approved trade names:Arcton 12  
Freon 12  
Isceon 12**Do not charge with methylchloride refrigerant. This would react undesirably with aluminium parts used in the system.**

- 1 Connect gauge set, see 82.30.01.
- 2 Discharge — compressor only, see 82.30.20.
- 3 Evacuate — compressor only, see 82.30.21.
- 4 Provide a supply of refrigerant to the gauge set centre manifold hose.

**NOTE:** This may be from single cans, from a multi-can manifold or from a service trolley container.

- 5 If the centre manifold hose contains air purge with refrigerant as follows:
  - a Protect the eyes with safety goggles and wear gloves during operation b.
  - b Carefully loosen the gauge set centre manifold hose connection. When refrigerant is seen to be escaping tighten the hose connection.

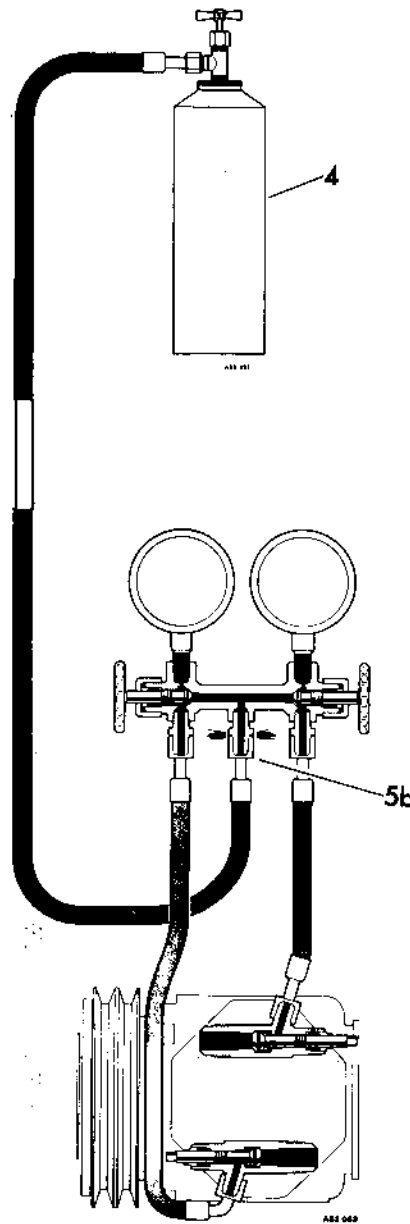

- 6 Provide a method of calculating at any time during the operation the weight of refrigerant put into the system.

**NOTE:** A single can or a multi-can manifold may be weighed by hanging from a spring balance. A service trolley container should have a graduated scale.

- 7 Note the datum refrigerant weight.
- 8 Open the discharge service valve to mid-position — turn anti-clockwise five turns.
- 9 Open the suction service valve to mid-position — turn anti-clockwise five turns.

**NOTE:** Operation 8 and 9 will allow high pressure refrigerant in the remainder of the system to enter the evacuated low pressure compressor.

- 10 Perform a first leak test on any disturbed joints, see 82.30.09.

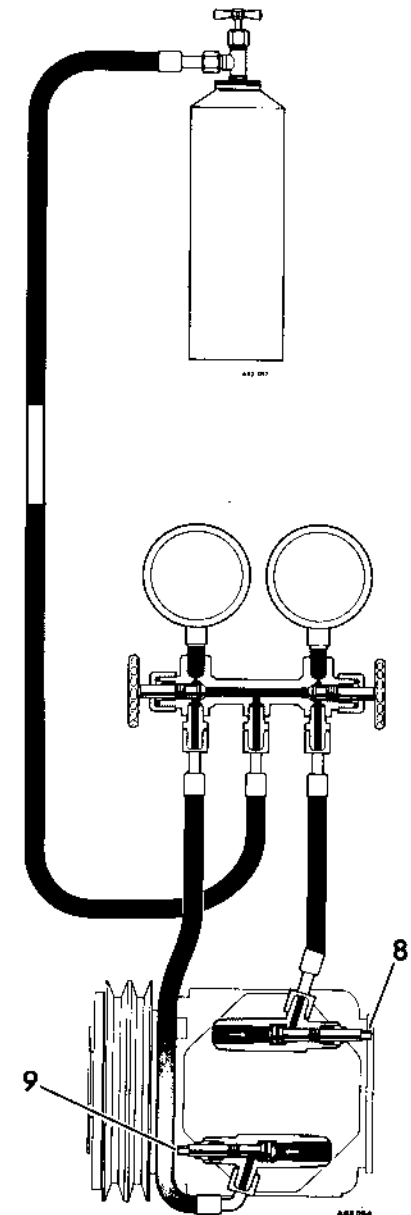

11 Close the discharge service valve to the back seat position – turn anti-clockwise.

12 Slightly open the gauge set suction valve. If the pressure differential between the container and the system permits, allow the flow to continue until 6 oz (170 g) of refrigerant has entered the system. Close the gauge set suction valve.

**NOTE:** High pressure liquid refrigerant from the container will vaporize on entering the system. Flow will continue until container pressure equals system pressure or until the gauge set suction valve is closed.

13 If 6 oz (170 g) of refrigerant has entered the system perform the following:

- a Close the suction service valve to the back seat position – turn anti-clockwise
- b Ignore operations 14 to 20.

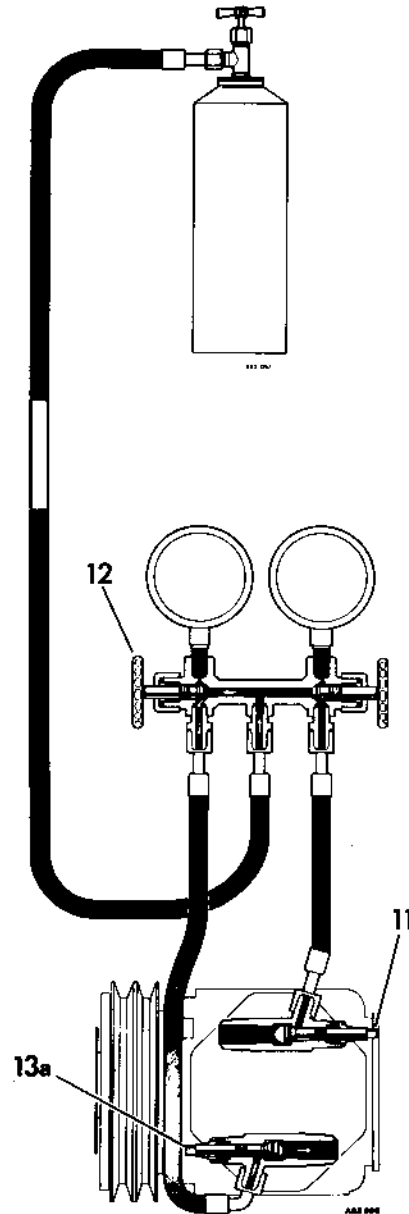

14 If the container pressure and the system pressure equalize before 6 oz (170 g) of refrigerant has entered the system perform operations 15 to 20.

15 Ensure that the gauge set suction valve is closed.

16 Connect the electrical connection to the compressor clutch.

17 Run the engine at 1000 to 1500 rev/min for 5 minutes with the control levers set as follows:

Lever A to MAX.  
Lever B to COLD  
Lever C to 3  
Lever D to CAR

This is to warm the engine and stabilize the system.

**NOTE:** Warm air from above the engine will enter the fresh air duct to be presented to the cold matrix. This condition will cause the system to operate hard and prevent frequent cutting in and out of the compressor clutch.

18 Slightly open the gauge set suction valve. Allow the flow to continue until 6 oz (170 g) of refrigerant – from the datum weight operation 7 – has entered the system. Close the gauge set suction valve.

**NOTE:** Compressor suction will draw further vaporized refrigerant into the system. The refrigeration circuit will commence to function and vapour passed into the condenser will accumulate as liquid refrigerant in the receiver drier.

19 Close the suction service valve to the back seat position – turn anti-clockwise.

20 Stop the engine.

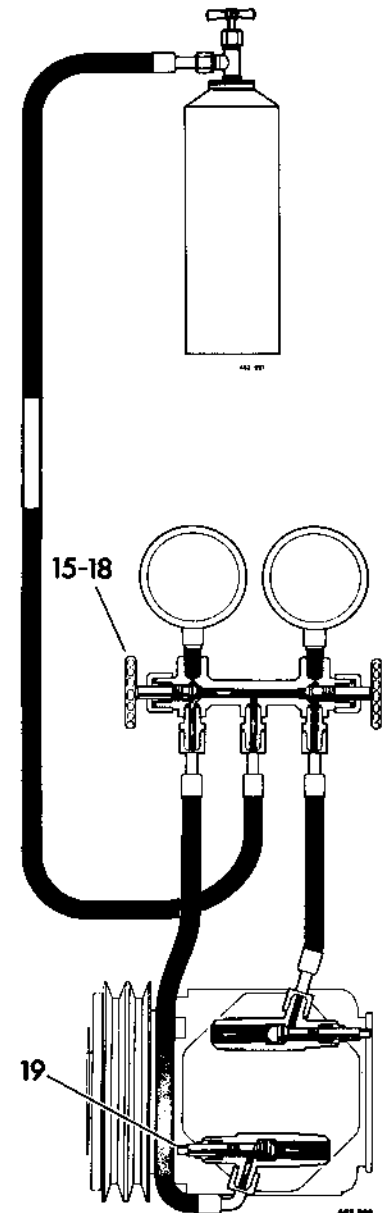

**Description 84.15.00**

The unit consists of a two speed permanent magnet motor and a gearbox unit which drives a cable rack mechanism. Rotation of the motor armature is converted to a reciprocating motion of the cable rack by a single stage worm and gear, a connecting rod and a cross head contained in a guide channel.

Two speed operation is provided by a third brush. When high speed is selected the positive supply is transferred from the normal speed brush to the high speed brush.

A switching feature stops the blades in the park position irrespective of their

position when the steering column switch is selected OFF. This is effected by a two stage limit switch unit attached to the gearbox. The contacts are actuated by a straight cam slope on a slider block which is traversed by a projection from the cross head.

When the steering column switch is selected OFF, the motor will continue to run until the limit switch first stage contacts open. A momentary period follows during which no contact is made. The second stage contacts then close causing regenerative braking of the armature which maintains consistent parking of the blades.

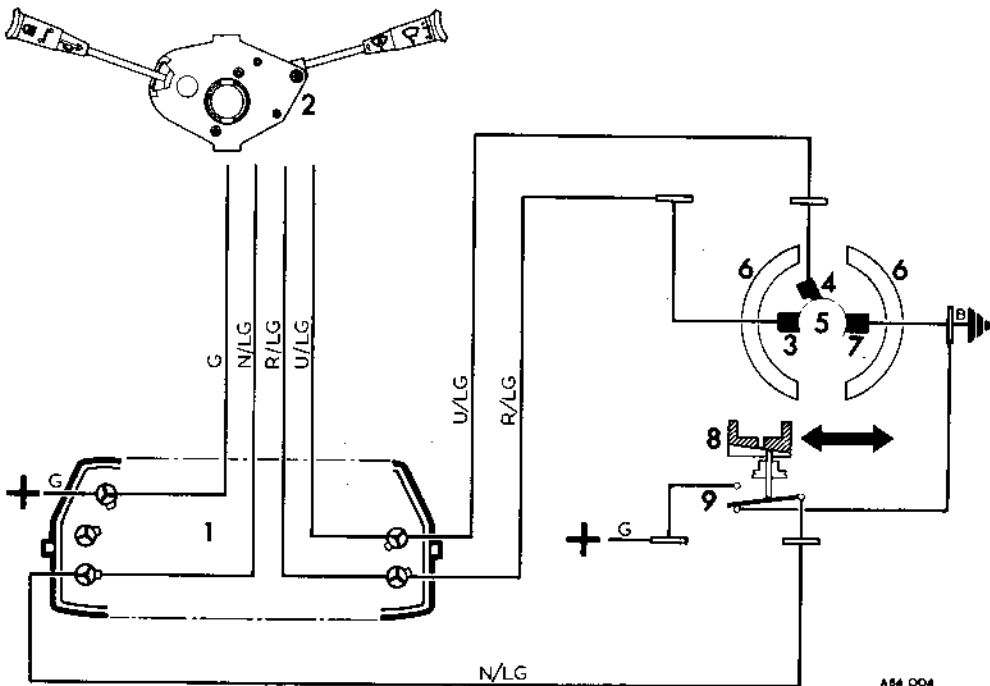

- + Supply
- 1. Steering column harness plug
- 2. Steering column multi-purpose switch-washer/wiper unit:
  - 2 HIGH SPEED G to U/LG
  - 0 NORMAL SPEED G to R/LG
  - 0 OFF N/LG to R/LG
  - 1 SWEEP WIPE FACILITY G to R/LG

- 3. Normal speed brush
- 4. High speed brush
- 5. Commutator
- 6. Permanent magnet
- 7. Earth brush
- 8. Slider block
- 9. Limit switch unit

**DATA**

**Motor**

Manufacturer .....	Lucas	84.15.00
Type .....	16W	
Lucas Part No.: motor minus gear assembly .....		
Triumph Part No.: motor minus gear assembly .....		
Running current—after 60 seconds from cold with connecting rod removed:		
Normal speed .....	1.5 amp	
High speed .....	2.0 amp	
Running speed—final gear after 60 seconds from cold with connecting rod removed:		
Normal speed .....	46 to 52 rev/min.	
High speed .....	60 to 70 rev/min.	
Armature end-float .....	0.002 to 0.008 in. (0.05 to 0.20 mm)	
Brush length—normal speed:		
new .....	0.380 in. (9.65 mm)	
renew if less than .....		
high speed:		
new .....	0.180 in. (4.76 mm)	
renew if less than .....		
earth:		
new .....	0.280 in. (7.11 mm) (i.e. when narrow section is worn to step into full width section)	
renew if less than .....		
new .....	0.380 in. (9.65 mm)	
renew if less than .....		
new .....	0.180 in. (4.76 mm)	
Brush spring pressure—when compressed so brush bottom is aligned with brushbox slot end .....	5 to 7 ozf (140 to 200 gf)	
Maximum permissible force to move cable rack in tubing—arms and blades removed .....	6 lbf (3 kgf)	



## WINDSCREEN WASHER RESERVOIR

Remove and refit 84.10.01

### Removing

- 1 Pull the windscreen washer reservoir pipe from the windscreen washer pump.
- 2 Lift the windscreen washer reservoir from the retaining bracket.

### Refitting

- 3 Reverse 1 to 2.

## WINDSCREEN WASHER JET

Remove and refit 84.10.09

### Removing

- 1 Pull the pipe from the jet.
- 2 Remove the nut and anti-vibration washer.  
**NOTE:** Take care not to drop the nut and anti-vibration washer as retrieval may prove difficult.
- 3 Remove the jet and rubber sealing washer.

### Refitting

- 4 Reverse 1 to 3. Fit the jet with the jet outlet in the correct location to the bonnet.
- 5 Close the bonnet and operate the pump to check the jet aim.
- 6 If necessary adjust the jet aim by using a screwdriver in the slot to slightly rotate the jet outlet.

## WINDSCREEN WASHER PUMP

Remove and refit 84.10.21

### Removing

- 1 Remove the windscreen washer reservoir, see 84.10.01 to obtain improved access.

- 2 Disconnect two Lucar connectors.
- 3 Note the positions of the inlet and outlet pipes. IN and OUT are stamped on the mounting bracket.
- 4 Pull the outlet pipe from the windscreen washer pump.
- 5 Remove two Pozidriv screws and washers. Remove the windscreen washer pump.  
**NOTE:** Take care not to drop the two Pozidriv screws and washers as retrieval may prove difficult.

### Refitting

- 6 Position the windscreen washer pump. Secure with two Pozidriv screws and washers.
- 7 Push the outlet pipe onto the windscreen washer pump in the position noted at operation 3 above.
- 8 Connect two Lucar connectors as follows:  
Light green/black wire to the positive terminal.  
Black wire to the negative terminal.
- 9 Refit windscreen washer reservoir, see 84.10.01.

## WINDSCREEN WASHER PUMP

Overhaul 84.10.24

The motor is a sealed unit and cannot be serviced. It is possible to dismantle and clean the interior of the pump as detailed below.

### Dismantling

- 1 Remove three screws.
- 2 Lift off the bracket.
- 3 Remove the pump cover.
- 4 Remove the rubber disc.
- 5 Remove the metal disc.
- 6 Remove the plastic disc.
- 7 Carefully withdraw the rotor.
- 8 Withdraw the rotor housing.

### Reassembling

- 9 Reverse 1 to 8. Ensure that all the components are assembled the correct way round as shown.

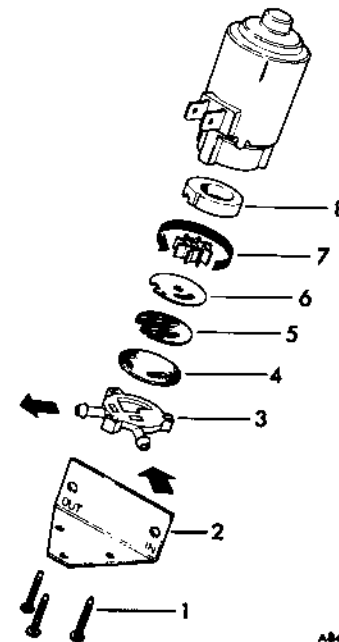

**WINDSCREEN WIPER ARM**

Driver's — remove and refit 84.15.02

**Removing**

- 1 Position a screwdriver as shown and impart a twisting action to lift the clip from the spindle groove.
- 2 The arm may now be removed from the spindle by hand.
- 3 Remove the spindle nut.
- 4 Remove the distance piece.
- 5 Remove the wiper arm pivot plate.

**Refitting**

- 6 Position the wiper arm pivot plate.
- 7 Position the distance piece with the tongue correctly located through the pivot plate, rubber gasket and body slot.
- 8 Fit the spindle nut.
- 9 Ensure that the spindle is in the 'park' position.
- 10 Locate the splines for a suitable 'park' position. Push on to engage the clip to the spindle groove.

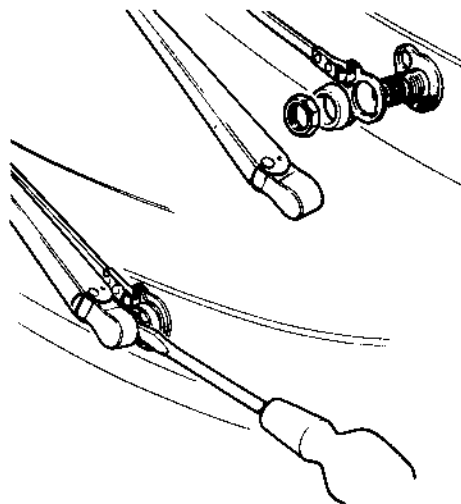

AB6 014

**WINDSCREEN WIPER BLADE**

Driver's — remove and refit 84.15.06

**Removing**

- 1 Lift the wiper arm and blade away from the screen.
- 2 Simultaneously depress the clip and withdraw the blade pin from the pivot block.

**CAUTION:** If the wiper blade refit is not to take place immediately protect the windscreen glass as follows: Bind the arm end with suitable tape. Isolate the battery to ensure that the wiper motor is not energised.

**Refitting**

- 3 Reverse 1 to 2.

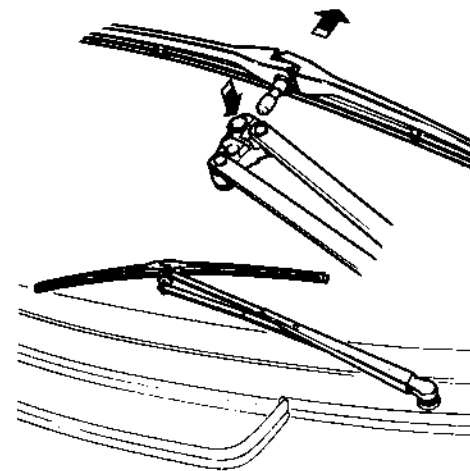

AB6 016

**WINDSCREEN WIPER ARM**

Passenger's — remove and refit 84.15.03

**Removing**

- 1 Lift the wiper arm and blade from the screen so that it falls into its service position.
- 2 Position a screwdriver as shown and impart a twisting action to lift the clip from the spindle groove.
- 3 The assembly may now be removed by hand.

**Refitting**

- 4 Ensure that the spindles are in the 'park' position.
- 5 Hinge the wiper arm against the spring to adopt its service position.
- 6 Locate the splines for a suitable 'park' position. Push on to engage the clip to the spindle groove.
- 7 Lower the wiper arm to the screen.

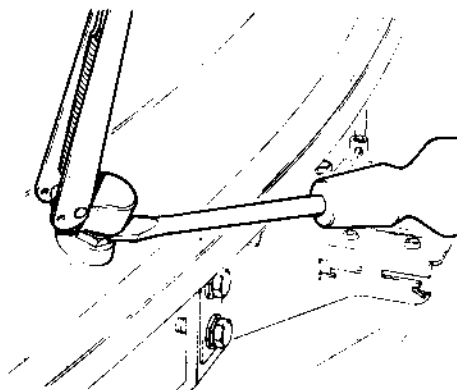

AB6 015

**WINDSCREEN WIPER BLADE**

Passenger's—remove and refit 84.15.07

**Removing**

- 1 Lift the wiper arm and blade from the screen so that it falls into its service position.
- 2 Simultaneously lift the clip and withdraw the blade pin from the arm.

**Refitting**

- 3 Reverse 1 to 2.

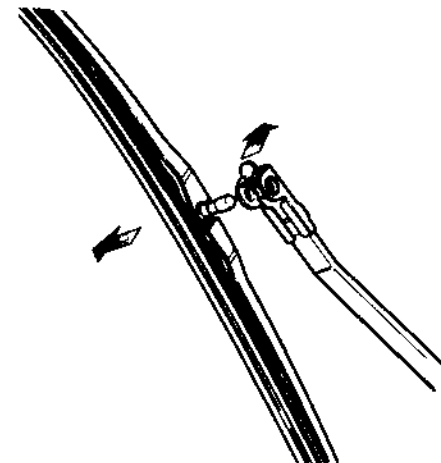

AB6 017

## WINDSCREEN WIPER SYSTEM

Motor and drive assembly –  
remove and refit 84.15.10

### Removing

- 1 Remove the passenger's wiper arm, see 84.15.03.
- 2 Remove the driver's wiper arm from the wheelbox spindle, see 84.15.02 operations 1 to 2.
- 3 Remove the fresh air duct, see 80.15.31.
- 4 Disconnect two 35 amp Lucar connectors from the battery lead connector.
- 5 Remove the windscreen washer reservoir tank.
- 6 Remove the battery, see 86.15.01.
- 7 Disconnect the harness plug.
- 8 Remove single screw. Disengage the clamp strap from the vehicle body slot.
- 9 Remove two Pozidriv screws and washers. Withdraw the plate adjacent to the brake master cylinder servo.
- 10 At the driver's wiper arm remove the spindle nut, distance piece, pivot plate and rubber gasket.
- 11 At the passenger's wiper arm remove the spindle nut, distance piece and rubber gasket.
- 12 Manoeuvre the motor and drive assembly from the vehicle.

### Refitting

- 13 Position the motor and drive assembly to the vehicle.
- 14 At the passenger's wiper arm fit the rubber gasket, distance piece and spindle nut.
- 15 At the driver's wiper arm fit the rubber gasket, pivot plate, distance piece and spindle nut.
- 16 Insert the plate adjacent to the brake master cylinder servo. Secure with two Pozidriv screws and washers.
- 17 Slacken the olive nut.
- 18 Ensure that the rubber pad is correctly positioned.
- 19 Position the motor and tubes for the best alignment.
- 20 Engage the clamp strap to the vehicle body slot. Secure with single screw.
- 21 Tighten the olive nut.
- 22 Connect the harness plug.
- 23 Fit the battery, see 86.15.01.
- 24 Fit the windscreen washer reservoir tank.
- 25 Connect two 35 amp Lucar connectors to the battery lead connector.
- 26 Fit the fresh air duct, see 80.15.31.
- 27 Run the motor and 'switch off' using the windscreen wiper switch so that the wheelbox spindles assume the park position.
- 28 Fit the driver's wiper arm to the wheelbox spindle, see 84.15.02 operations 9 to 10.
- 29 Fit the passenger's wiper arm, see 84.15.03.

## WINDSCREEN WIPER SYSTEM

Motor — remove and refit 84.15.12

### Removing

- 1 Remove the motor and drive assembly, see 84.15.10.
- 2 Remove five screws. Lift off the gearbox cover.
- 3 Remove the crankpin spring clip by withdrawing sideways. Remove the washer.
- 4 Carefully withdraw the connecting rod. Remove the washer.
- 5 Lift out the cross-head, rack and tube assembly.

### Refitting

- 6 Lubricate all moving parts of the motor during assembly as instructed on the illustration.
- 7 Position the slider block with the direction of cam slope as shown.
- 8 Position the cross-head, rack and tube assembly locating the projection in the slider block slot.
- 9 Fit the washer. Carefully insert the connecting rod.
- 10 Fit the washer. Fit the crankpin spring clip by inserting sideways.
- 11 Position the gearbox cover. Secure with five screws.
- 12 Fit the motor and drive assembly, see 84.15.10.

RLG Ragosine Listate grease  
ST410 Shell turbo 41 oil

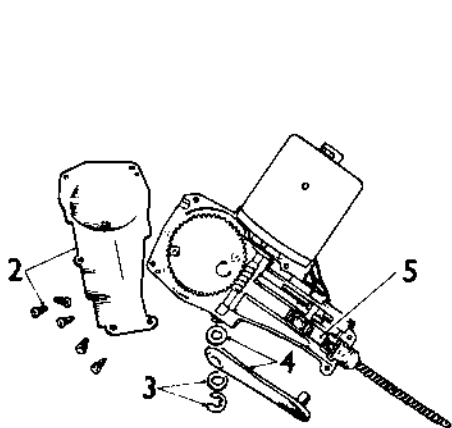

AB4 007A

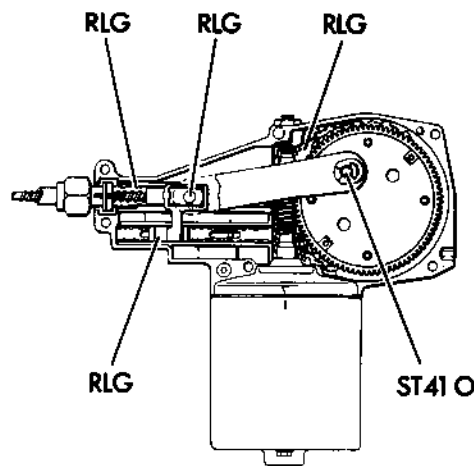

AB4 003

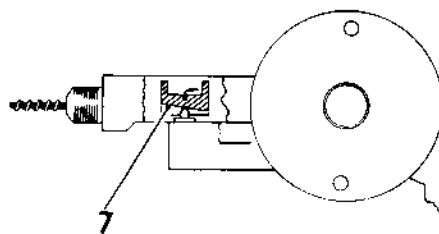

AB4 009A

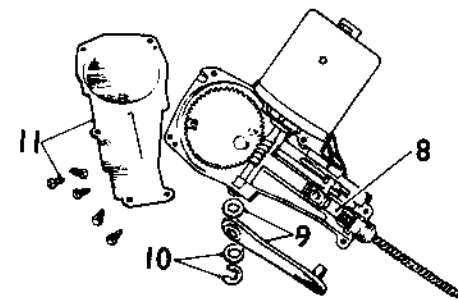

AB4 006A

## WINDSCREEN WIPER MOTOR

Overhaul 84.15.18

### Dismantling

- 1 Remove five screws. Lift off the gearbox cover.
- 2 Lift out the slider block.
- 3 Remove the crankpin spring clip by withdrawing sideways. Remove the washer.
- 4 Carefully withdraw the connecting rod. Remove the washer.
- 5 Remove the final gear shaft spring clip by withdrawing sideways. Remove the washer.
- 6 Ensure that the shaft is burr-free and withdraw it. Remove the dished washer.
- 7 Remove the thrust screw and locknut.
- 8 Remove the through bolts.

- 9 Carefully withdraw the cover and armature about 0.2 in (5 mm). Continue withdrawal allowing the brushes to drop clear of the commutator. Ensure that the three bushes are not contaminated with grease.
- 10 Pull the armature from the cover against the action of the permanent magnet.
- 11 Scribe a line round the limit switch to note its position on the gearbox.
- 12 Remove three screws to release the brush assembly.
- 13 Remove two screws and washers to release the limit switch.
- 14 Remove both units joined together by the wires.
- 15 Remove the plate.

### Reassembling

- 16 Lubricate all moving parts of the motor during assembly as instructed in the text and on the illustration.
- 17 Position the plate so that the round hole will accommodate the limit switch plunger.
- 18 Position the limit switch to the scribe lines made at operation 11 above. Secure with two screws and washers.
- 19 Secure the brush assembly with three screws.
- 20 Lubricate the cover bearing and saturate the cover bearing felt washer with Shell Turbo 41 oil.
- 21 Position the armature to the cover against the action of the permanent magnet.
- 22 Lubricate the self-aligning bearing with Shell Turbo 41 oil.
- 23 Ensure that the three brush springs and brushes are correctly positioned. Retain in position using slave clips locally made from paper clips or similar wire as shown.
- 24 Carefully insert the armature shaft through the bearing. Ensure that the brushes are not contaminated with lubricant. Ensure that the commutator clears the brushes.
- 25 With the brushes over the commutator remove the slave clips.

*continued*

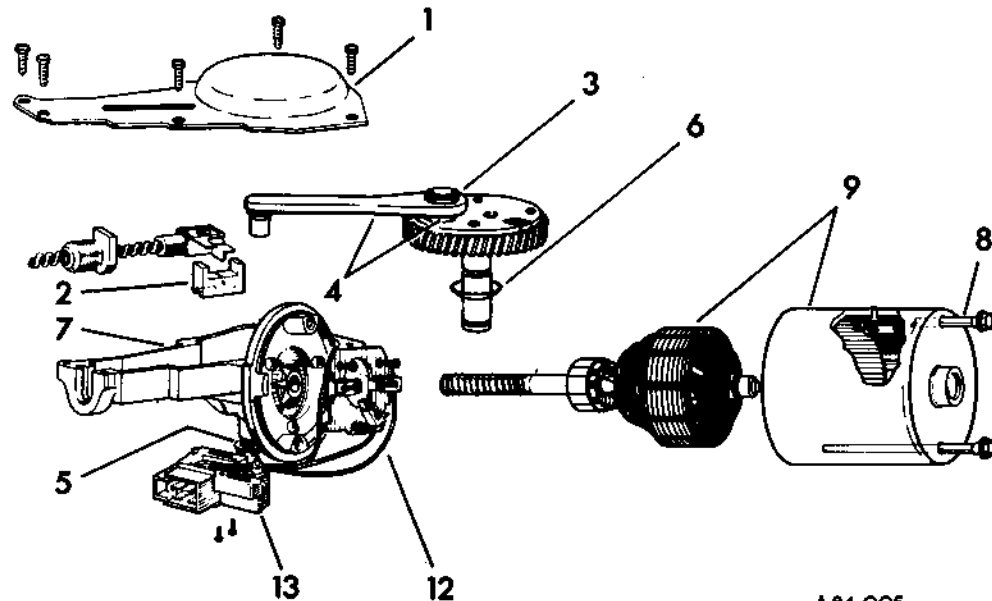

A 84 005

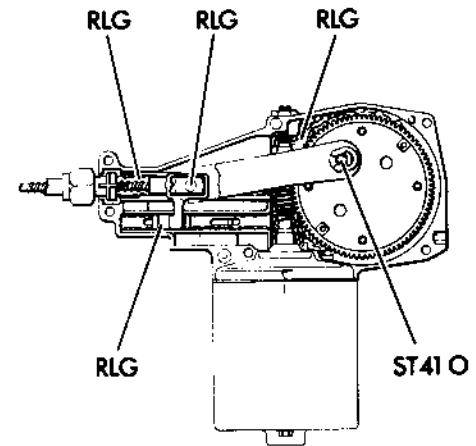

RLG Ragosine Listate grease  
ST410 Shell turbo 41 oil

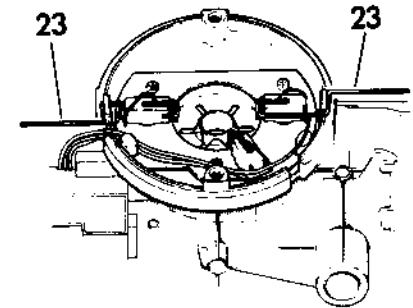

A 84 002

- 26 Seat the cover against the gearbox. Turn the cover to align the marks shown. Fit the through bolts.
  - 27 Fit the thrust screw and locknut.
  - 28 Adjust the armature end-float as follows:  
Slacken the locknut. Screw the thrust screw in until resistance is felt. Screw the thrust screw out a quarter of a turn – maintain in this position and tighten the locknut.
  - 29 Lubricate the final gear bushes with Shell Turbo 41 oil.
  - 30 Fit the dished washer with its concave surface facing the final gear. Insert the shaft.
  - 31 Fit the washer. Fit the spring clip by inserting sideways.
- NOTE:** If the motor is to be immediately fitted to the motor and drive assembly, ignore operations 32 to 35. Refit the motor, see 84.15.12. If the motor is to be stored perform the remaining operations.
- 32 Position the slider block with the direction of cam slope as shown.
  - 33 Fit the washer. Carefully insert the connecting rod.
  - 34 Fit the washer. Fit the crankpin spring clip by inserting sideways.
  - 35 Position the gearbox cover. Secure with five screws.

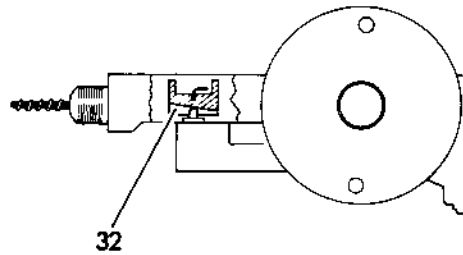
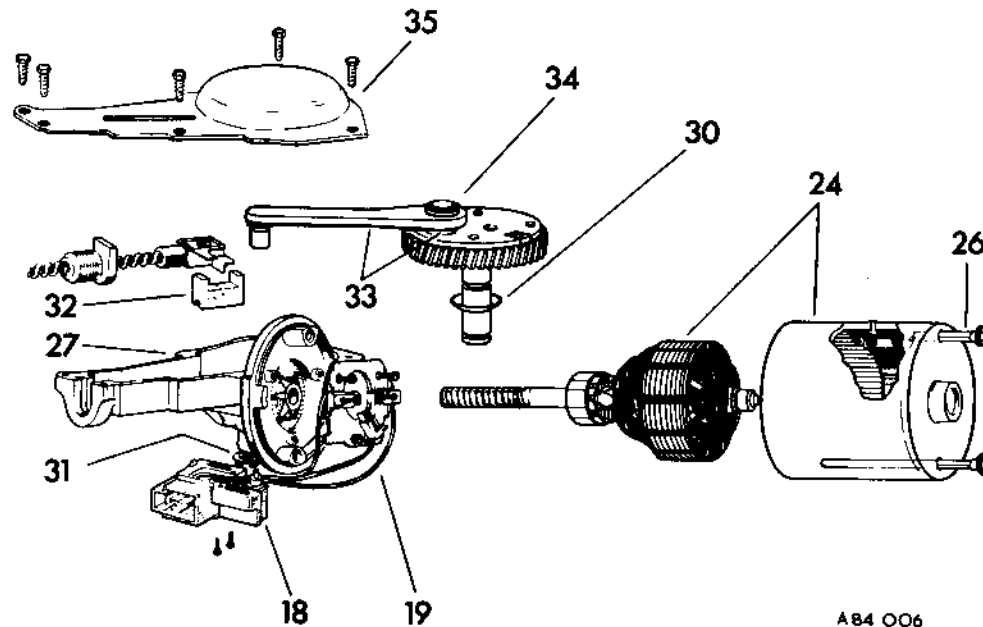
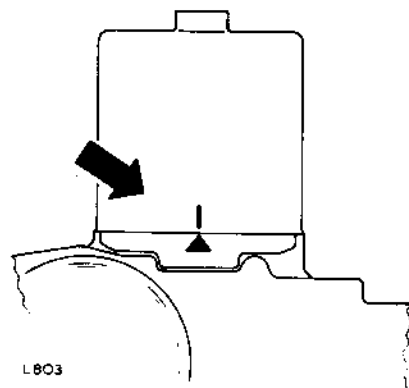

A84 010

A84 006

## WINDSCREEN WIPER SYSTEM

Rack – remove and refit 84.15.24

## Removing

- 1 Remove the motor and drive assembly, see 84.15.10.
- 2 Remove the motor, see 84.15.12.
- 3 Withdraw the rack from the tube assembly.
- 4 Remove the ferrule.

## Refitting

- 5 Fit the ferrule.
- 6 Lubricate the rack with Ragosine Listate grease.
- 7 Insert the rack into the tube assembly. If necessary slightly rotate the wheelbox spindles by hand to facilitate rack engagement.
- 8 Fit the motor, see 84.15.12.
- 9 Fit the motor and drive assembly, see 84.15.10.

## WINDSCREEN WIPER SYSTEM

Wheelbox -- driver's -- remove  
and refit 84.15.28

### Removing

- 1 Remove the motor and drive assembly, see 84.15.10.
- 2 Scribe a line to note the radial position of the tube.
- 3 Remove two nuts. Remove the wheelbox plate.
- 4 Disengage and remove the short straight tube.
- 5 Disengage and remove the wheelbox.

### Refitting

- 6 If a new wheelbox is to be fitted reproduce the scribe line on the new unit.
- 7 Fit the wheelbox the correct way round.
- 8 Lubricate the wheelbox and exposed section of the rack with Ragosine Listate grease.
- 9 Reverse 1 to 4.

## WINDSCREEN WIPER SYSTEM

Wheelbox -- passenger's --  
remove and refit 84.15.29

### Removing

- 1 Remove the motor and drive assembly, see 84.15.10.
- 2 Scribe two lines to note the radial position of the tube.
- 3 Remove two nuts. Remove the wheelbox plate.
- 4 Disengage and remove the tube and far wheelbox assembly.
- 5 Disengage and remove the wheelbox.

### Refitting

- 6 If a new wheelbox is to be fitted reproduce the scribe lines on the new unit.
- 7 Fit the wheelbox the correct way round.
- 8 Lubricate the wheelbox and exposed section of the rack with Ragosine Listate grease.
- 9 Reverse 1 to 4.

WIRING DIAGRAM – TR7 RIGHT- AND LEFT-HAND STEERING – UK AND EUROPE

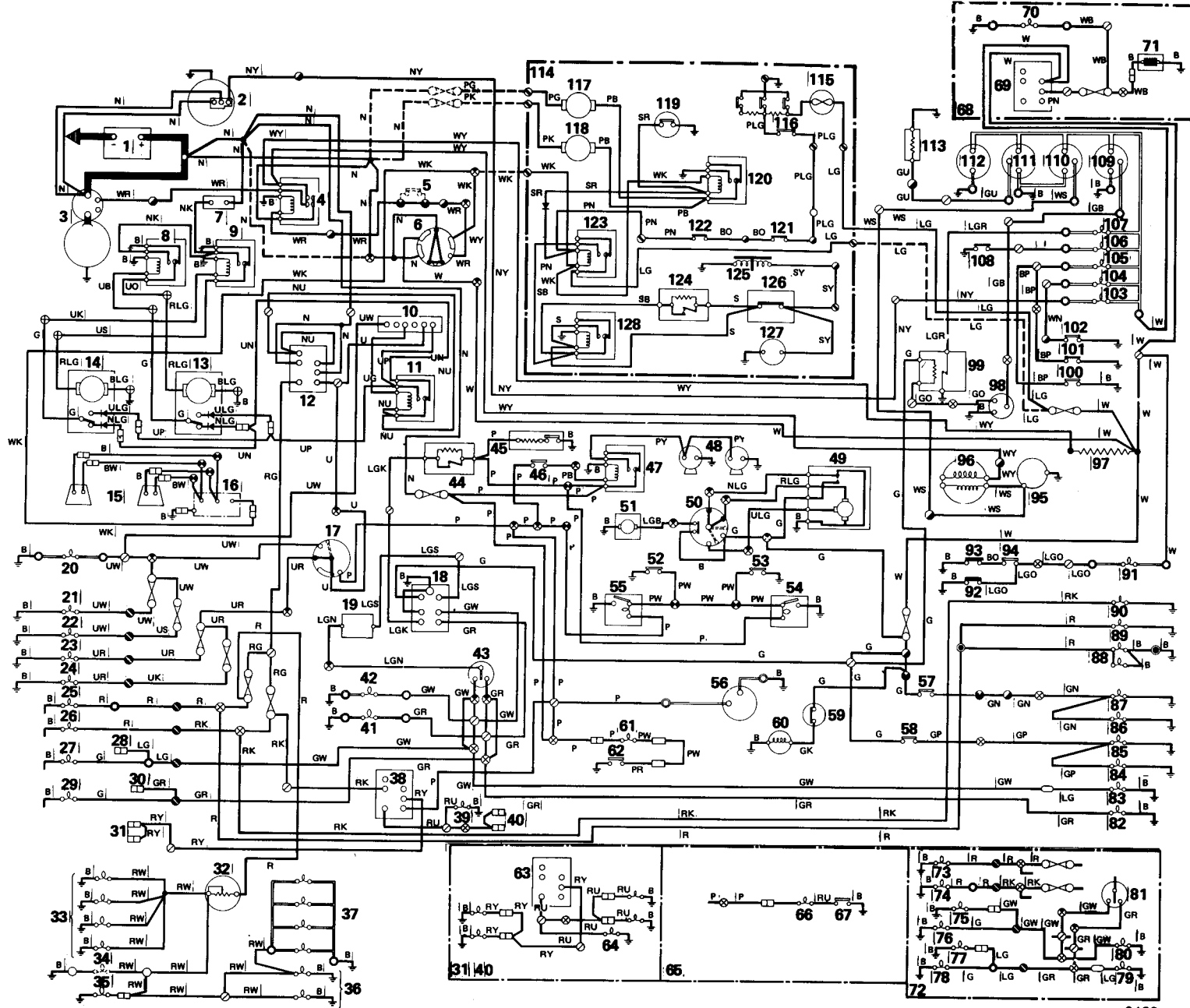



## WIRING DIAGRAM KEY

### TR7 RIGHT- AND LEFT-HAND STEERING – UK AND EUROPE

1	Battery	34	Borg-Warner illumination	66	Boot lamp	96	6 volt coil
2	Alternator	35	Cigar lighter illumination	67	Boot lamp switch	97	Eureka wire
3	Starter motor	36	Switch panel illumination	68	Heated rear screen assembly – TR7 coupé	98	Tank unit
4	Starter motor relay	37	Panel illumination	69	Heated rear screen switch	99	Low fuel delay unit
5	Start inhibit switch (Automatic)	38	Fog lamps switch	70	Heated rear screen warning light	100	Brake pressure differential switch
6	Ignition switch	39	Rear fog lamps warning light	71	Heated rear screen	101	Hand brake switch
7	Headlamp motor circuit breaker	40	Rear fog lamps junction	72	Wiring condition for front, side and front and rear indicator lights – L.H. steering	102	Oil pressure switch
8	Headlamp relay	41	L.H. indicator warning light	73	Sidelight	103	Ignition warning light
9	Headlamp relay	42	R.H. indicator warning light	74	Sidelight	104	Oil warning light
10	Headlamp flash control	43	Direction indicator switch	75	Side repeater	105	Brake warning light
11	Headlamp flash relay	44	Hazard unit	76	Side indicator	106	Choke warning light
12	Master light switch	45	Cigar lighter	77	Side repeater	107	Low fuel warning light
13	Headlamp motor	46	Horn-push	78	Side indicator	108	Choke warning light switch
14	Headlamp motor	47	Horn relay	79	Rear side indicator	109	Fuel gauge
15	Loudspeakers	48	Horns	80	Rear side indicator	110	Tachometer
16	Radio	49	Windscreen wiper motor	81	Direction indicator switch	111	Temperature gauge
17	Main dip flash switch	50	Windscreen wipe/wash switch	82	Side indicator	112	Battery condition indicator
18	Hazard switch	51	Windscreen washer motor	83	Side indicator	113	Temperature transmitter
19	Flasher unit	52	Door switch	84	Stop light	114	Air conditioning blower unit
20	Main beam warning light	53	Door switch	85	Stop light	115	Heater/air conditioning blower unit
21	Main beam	54	Courtesy light	86	Reverse light	116	Thermostat
22	Main beam	55	Courtesy light	87	Reverse light	117	R.H. condenser fan
23	Dip beam	56	Clock	88	Number-plate lights	118	L.H. condenser fan
24	Dip beam	57	Reverse light switch	89	Tail light	119	Radiator thermostat
25	Sidelight	58	Stop light switch	90	Tail light	120	Fan relay
26	Sidelight	59	Engine thermostat	91	Seat belt warning light	121	Full throttle cut-off switch
27	Side indicator	60	F.A.S.D.	92	Driver's buckle switch	122	Air conditioning cut-out switch
28	Side repeater connection	61	Boot lamp	93	Passenger belt switch	123	Air conditioning relay
29	Side indicator	62	Boot lamp switch	94	Passenger seat switch	124	Delay unit
30	Side repeater connection	63	Fog switch	95	Distributor	125	Throttle jack
31	Front fog lamps junction	64	Rear fog lamp warning light			126	Ranco valve high pressure cut-out
32	Panel rheostat	65	Boot lamp and switch wiring assembly – L.H. steering			127	Clutch
33	Heater control illumination					128	Clutch relay

#### COLOUR CODE

B	Black	N	Brown	S	Slate
G	Green	O	Orange	U	Blue
K	Pink	P	Purple	W	White
LG	Light green	R	Red	Y	Yellow

# WIRING DIAGRAM - TR7 USA - AIR CONDITIONING

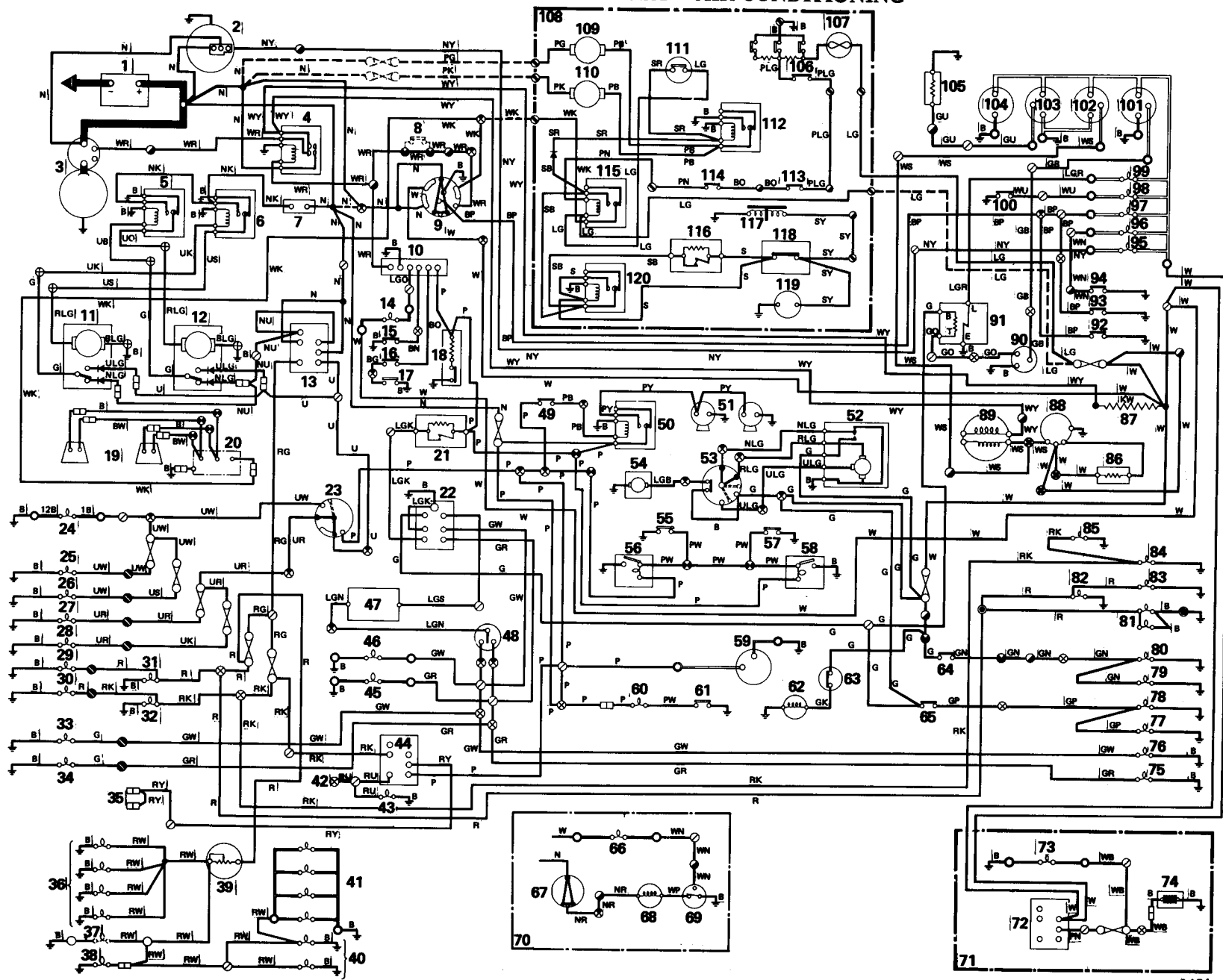

**WIRING DIAGRAM KEY**  
**TR7 – TR7 USA – AIR CONDITIONING**

1 Battery	31 R.H. side marker	61 Boot lamp switch	91 Low fuel relay unit
2 Alternator	32 L.H. side marker	62 F.A.S.D.	92 Brake pressure differential switch
3 Starter motor	33 R.H. side indicator	63 Engine thermostat	93 Hand brake switch
4 Starter motor relay	34 L.H. side indicator	64 Reverse light switch	94 Oil pressure switch
5 R.H. headlamp relay	35 Front fog lamps junction	65 Stop light switch	95 Ignition warning light
6 L.H. headlamp relay	36 Heater control illumination	66 Oil warning light	96 Oil warning light
7 Headlamp motor circuit breaker	37 Borg-Warner illumination	67 Ignition switch	97 Brake warning light
8 Start inhibit switch (Automatic)	38 Cigar lighter illumination	68 Anti-run-on valve	98 Choke warning light
9 Ignition switch	39 Panel rheostats	69 Oil pressure switch	99 Low fuel warning light
10 Buzzer timer unit	40 Switch panel illumination	70 Anti-run-on valve – California market only	100 Choke warning light switch
11 L.H. headlamp motor	41 Panel illumination	71 Heated rear screen – TR7 coupé	101 Fuel gauge
12 R.H. headlamp motor	42 Rear fog lamps illumination	72 Heated rear screen switch	102 Tachometer
13 Master light switch	43 Rear fog lamps warning light	73 Heated rear screen warning light	103 Temperature gauge
14 Seat belt warning light	44 Fog lamps switch	74 Heated rear screen	104 Battery condition indicator
15 Buckle switch	45 L.H. indicator warning light	75 L.H. side indicator	105 Temperature transmitter
16 Door switch	46 R.H. indicator warning light	76 R.H. side indicator	106 Thermostat
17 Audible warning	47 Flasher unit	77 L.H. stop light	107 Heater/air conditioning blower unit
18 Cigar lighter	48 Direction indicator switch	78 R.H. stop light	108 Air conditioning circuit
19 Loudspeakers	49 Horn-push	79 L.H. reverse light	109 R.H. condenser fan
20 Radio	50 Horn relay	80 R.H. reverse light	110 L.H. condenser fan
21 Hazard unit	51 Horns	81 Number-plate lights	111 Radiator thermostat
22 Hazard switch	52 Windscreen wiper motor	82 R.H. side marker	112 Fan relay
23 Main/dip/flash switch	53 Windscreen wipe/wash switch	83 R.H. tail lights	113 Full throttle cut-off switch
24 Main beam warning light	54 Windscreen washer motor	84 L.H. tail lights	114 Air conditioning cut-out switch
25 R.H. main beam	55 Door switch	85 L.H. side marker	115 Air conditioning relay
26 L.H. main beam	56 Courtesy light	86 Drive resistor	116 Delay unit
27 R.H. dip beam	57 Door switch	87 Eureka wire (1.3 to 1.5 ohms)	117 Throttle jack
28 L.H. dip beam	58 Courtesy light	88 Distributor	118 Ranco valve high pressure cut-off
29 R.H. sidelight	59 Clock	89 6 volt	119 Clutch
30 L.H. sidelight	60 Boot lamp	90 Tank unit	120 Clutch relay

**COLOUR CODE**

N	Brown	LG	Light Green
U	Blue	W	White
R	Red	Y	Yellow
P	Purple	S	Slate
G	Green	B	Black
K	Pink	O	Orange

## BULB CHART

86.00.00

	Watts	Lucas Part No.	Unipart No.	Triumph Part No.	
<b>Headlamps:</b>					
L.H. dip. ....	75/60		UKC 2423		†
R.H. dip – Normal	60/50	54523079	GLU 114	215735	†
France .....	45/40	411	GLB 411	510219	
U.S.A. ....	50/40			514578	†
Front parking lamp	4				
Front flasher lamp	21	382	GLB 382	502379	
Front marker lamp	3	504	GLB 504	518414	
Rear marker lamp	3	504	GLB 504	518414	
Tail lamp	5	207	GLB 207	57591	
Stop lamp	21	382	GLB 382	502379	
Rear flasher lamp	21	382	GLB 382	502379	
Reverse lamp	21	382	GLB 382	502379	
Plate illumination lamp	5	207			
Map/courtesy lamp	7				
Instrument panel illumination	2.2				
Instrument panel warning light	1.2	286		UKC 2412	
Hazard warning light	1.2	286		UKC 2412	

† Sealed beam light unit

## ALTERNATOR DATA CHART

86.10.00

**CAUTION:** The alternator contains polarity sensitive components that may be irreparably damaged if subjected to incorrect polarity.

Do not connect or disconnect any part of the charging circuit – including the battery leads – while the engine is running. Run the alternator with all connections made or with the unit disconnected.

<b>Manufacturer Type</b>	Lucas 17 ACR	Lucas 20 ACR Dual sensed – battery sensed with machine sensed safety control European terminations	
<b>Part numbers--</b>	<b>Lucas Part No.</b>	<b>Stanpart No.</b>	<b>Lucas Part No.</b>
assembly	–	TKC 0863	54021510 TKC 0905
– comprising – alternator	23818	TKC 0864	23817 TKC 0906
fan	54217652	147990	54216943 157069
pulley	54217767	154334	54201395 157083
<b>Polarity</b>	Negative earth only		Negative earth only
<b>Brush length</b>	0.5 in (12.70 mm)		0.5 in (12.70 mm)
– new	0.2 in (5.00 mm) protrudes from brushbox when free		0.2 in (5.00 mm) protrudes from brushbox when free
– renew if less than	9 to 13 oz (255 to 370 g) at face flush with brushbox		9 to 13 oz (255 to 370 g)
<b>Brush spring pressure</b>	6 diodes (3 live side and 3 earth side)		6 diodes (3 live side and 3 earth side)
<b>Rectifier pack</b>	3 diodes		3 diodes
– output rectification	Three phase – star connected		Three phase – delta connected
– field winding supply rectification	15,000 rev/min		15,000 rev/min
<b>Stator windings</b>	9/16 in – 18 U.N.F.		M16 – 1.5
<b>Field winding rotor</b>	Dual sensed – battery sensed with machine sensed safety control		3.2 ± 5% ohm
– poles	14 TR		–
– maximum permissible speed	European		–
– shaft thread	Metric M8 – 1.25		–
<b>Field winding resistance at 20°C</b>	Hot		Hot
<b>Control</b>	6000 rev/min		6000 rev/min
	2540 rev/min		2540 rev/min
	14 volt		14 volt
	36 amp		66 amp

## ALTERNATOR – LUCAS TYPES 17ACR and 20ACR

Remove and refit

86.10.02

### Removing

- 1 Isolate the battery.
- 2 Slide the harness plug lock to the unlock position – inboard and down.
- 3 Disconnect the harness plug.
- 4 Slacken the adjustment bolt.
- 5 Slacken the support bracket bolt.
- 6 Slacken the main mounting bolt.
- 7 Push the alternator towards the engine and remove the drive belt from the pulley.
- 8 Remove the adjustment bolt and washer.
- 9 Remove the nut and washer.
- 10 Support the weight of the alternator. Withdraw the main mounting bolt and washer. Lift the alternator from the vehicle.

### Refitting

- 11 Position the alternator to the mounting bracket. Insert the main mounting bolt and washer.
- 12 Fit the nut and washer finger tight.
- 13 Fit the adjustment bolt and washer finger tight.
- 14 Push the alternator towards the engine and fit the drive belt to the pulley.
- 15 Perform 86.10.05 operations 4 to 7.
- 16 Connect the harness plug.
- 17 Slide the harness plug lock to the lock position – outboard and up.
- 18 Connect the battery.

## ALTERNATOR – LUCAS TYPES 17ACR and 20ACR

Drive belt – adjust 86.10.05

- 1 Slacken the adjustment bolt.
- 2 Slacken the support bracket bolt.
- 3 Slaken the main mounting bolt.
- 4 Carefully lever the alternator away from the engine to tension the belt. Tighten the adjustment bolt.  
**CAUTION:** To prevent bearing damage when tensioning the belt use a lever of soft material—preferably wood—applied to the alternator drive end bracket. Do not lever on any other part of the alternator.
- 5 Check the belt tension. Total movement should be 0.75 to 1.00 in (20 to 25 mm) at the mid-point of the longest run.
- 6 Tighten the support bracket bolt.
- 7 Tighten the main mounting bolt.

## ALTERNATOR – LUCAS TYPE 17 ACR

Overhaul 86.10.08

This overhaul instruction is specific to alternator Lucas part number 23818. Other units may differ slightly.

### Dismantling

- 1 Remove the moulded cover.
- 2 Before disturbing any wires note the wire positions and colours.
- 3 Remove the brushbox, regulator and surge protection diode assembly as follows:  
Remove screw to release surge protection diode. Disconnect four Lucar connectors from the rectifier pack. Remove two screws to release the brushbox. Lift away the assembly.
- 4 If required, the regulator may be detached from the assembly as follows:  
Remove screw to release one wire eyelet. Remove screw to release the regulator. Disengage two lugs and lift away the regulator. Collect up the spacer.
- 5 Remove screw to release the radio capacitor.
- 6 Note the position of the three stator wires on the rectifier pack.
- 7 Unsolder the three stator wire connections. Do not overheat the diodes or bend the diode pins. Solder quickly and provide a heat sink by gripping the diode pin with pliers.
- 8 Remove screw to release the rectifier pack earth strip. Slacken the nut and withdraw the rectifier pack.
- 9 Remove the through-bolts.
- 10 Provide an extractor tool as shown.

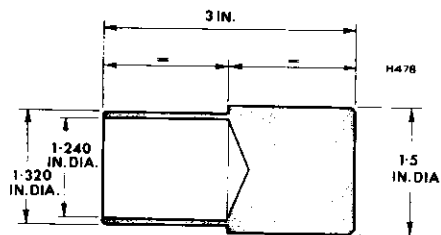

- 11 To remove the slip-ring end bracket, position the extractor tool to engage with the outer journal of the slip-ring end bearing. Employ a second operator to support the slip-ring end bracket by hand. Carefully tap the extractor tool to drive the bearing from the housing.

**NOTE:** It may be necessary to carefully file away surplus solder from the two field winding connections on the slip-ring moulding if the exterior tool will not pass over the moulding.

- 12 The rubber 'O' ring fitted in the slip-ring end bracket bearing housing may remain *in situ* unless replacement is contemplated.
- 13 Remove the stator windings from the drive end bracket.
- 14 Prevent the rotor turning by wrapping a scrap fan belt round the pulley and retaining by hand or vice. Remove the nut, spring washer, pulley and fan. If necessary, use a suitable extractor.
- 15 Remove the key.
- 16 Using a suitable press, remove the rotor from the drive end bracket.  
**CAUTION:** Do not attempt to remove the rotor by applying hammer blows to the shaft end. Such action may burr over and damage the thread.
- 17 Collect up the thick spacer.
- 18 Remove the thin spacer from the rotor shaft.

### Reassembling

- 19 Fit the thin spacer to the rotor shaft.
- 20 Using a suitable press, the thick spacer and a suitable tube, fit the rotor to the drive end bracket by applying pressure to the bearing inner journal.  
**CAUTION:** Do not use the drive-end bracket as a support while fitting the rotor. If the spacer is not employed, the felt ring may be damaged.

- 21 Fit the key.
- 22 Fit the fan, pulley, spring washer and nut. Prevent the rotor turning by wrapping a scrap fan belt round the pulley and retaining by hand or vice. Torque load the nut to 25 to 30 lbf ft (3.46 to 4.15 kgf m).
- 23 Observe the relationship of the stator windings to the drive-end bracket determined by the stator wire connections, the rectifier pack position on the slip-ring end bracket, the alignment of the mounting lugs on the end brackets and the through-bolt clearances on the stator windings.
- 24 Position the stator windings to the drive-end bracket.
- 25 Ensure that the rubber 'O' ring is fitted correctly in the slip-ring end bracket bearing housing.
- 26 Fit the slip-ring end bracket by carefully pushing the bearing into the housing.
- 27 Fit the through-bolts, tightening evenly.
28. Position the rectifier pack. Fit screw to secure the rectifier pack earth strip. Tighten the nut to secure the rectifier pack.
- 29 Position three stator wires on the rectifier pack as noted in operation 6.
- 30 Solder three stator wire connections. Note the precautions stated in operation 7 and use 'M' grade 45-55 resin core solder.
- 31 Position the radio capacitor. Fit the screw to secure.
- 32 If required, attach the regulator to the brushbox, regulator and surge protection diode assembly as follows: Position the spacer. Position the regulator. Fit screw to secure the regulator. Fit screw to secure one wire eyelet.
- 33 Fit the brushbox, regulator and surge protection diode assembly as follows: Position the assembly. Fit two screws to secure the brushbox, include one earth wire eyelet under one screw head. Connect four Lucar connectors to the rectifier pack. Fit screw to secure surge protection diode.
- 34 Fit the moulded cover.

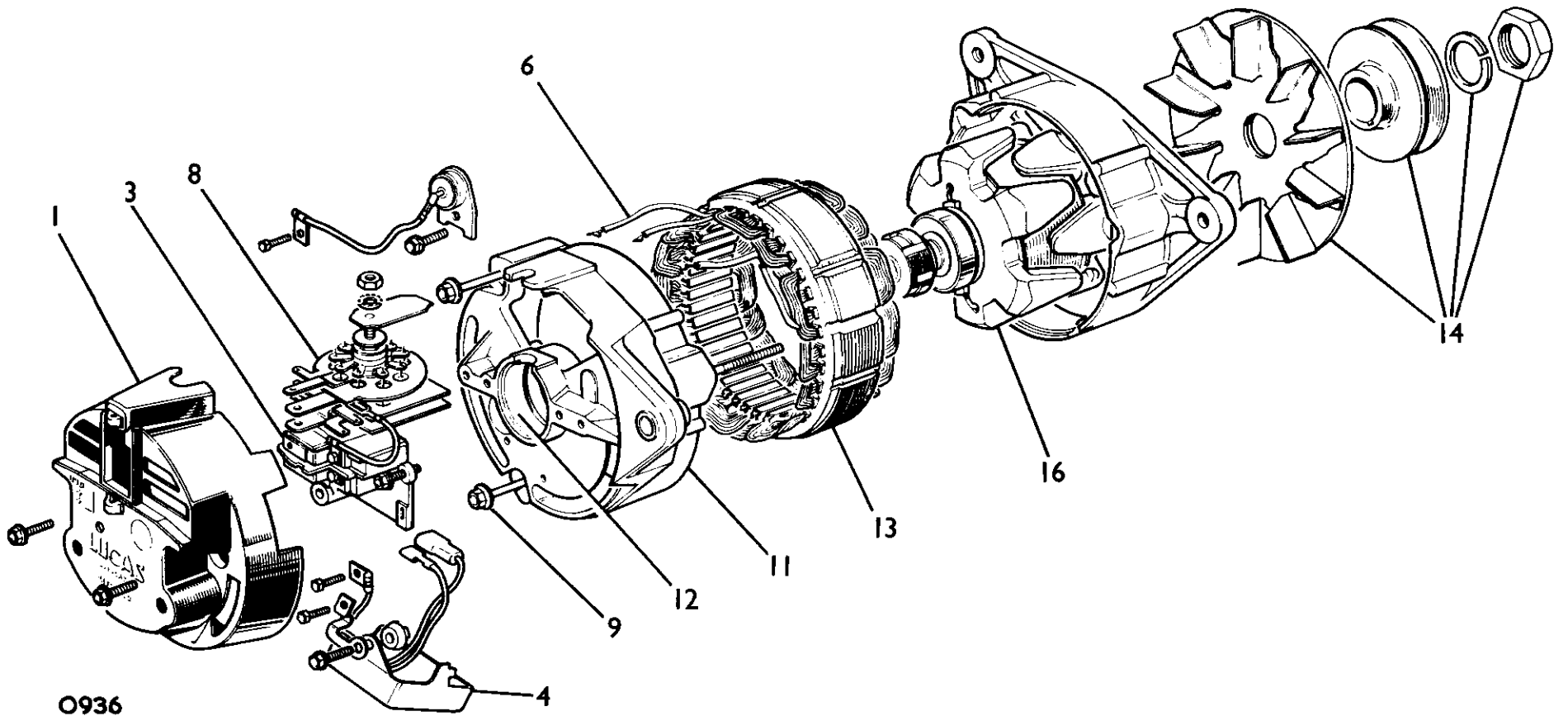

O936

LUCAS 17ACR ALTERNATOR

# ALTERNATOR – LUCAS TYPE 20ACR

Overhaul

86.10.08

## Dismantling

- 1 Remove two screws, washers and spring washers. Remove the cover.
- 2 Note the wire positions and colour codes.
- 3 Disconnect the red wire small Lucar connector.
- 4 Disconnect the white wire small Lucar connector.
- 5 Disconnect the red wire large Lucar connector.
- 6 Remove the screw, washer and spring washer.
- 7 Remove the screw and spring washer.
- 8 Remove the screw, washer and spring washer.
- 9 Lift out the brushbox, regulator and surge protection diode assembly.
- 10 If necessary detach the regulator from the brushbox as follows—  
Remove the screw to release one wire eyelet. Remove the screw to release the regulator. Bend up the contact strap. Disengage two lugs and lift away the regulator. Collect up the spacer.
- 11 Remove three pozidriv screws.
- 12 Remove the earth strap screw and spring washer.
- 13 Remove three screws, washers and spring washers.
- 14 Lift out the rectifier pack.
- 15 Scribe a line across the slip ring end bracket, stator winding and drive end bracket.

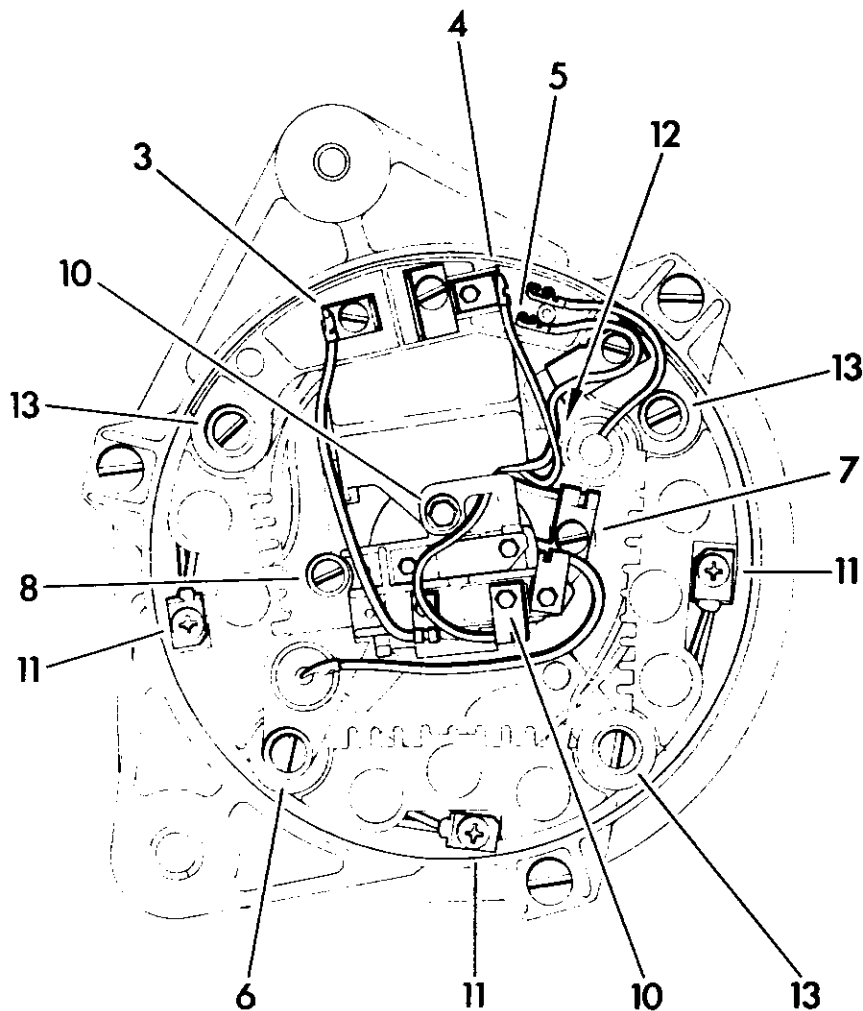

A86-068

- 16 Remove three side bolts and spring washers.
- 17 Collect up three nuts.
- 18 Provide an extractor tool as shown.
- 19 To remove the slip ring end bracket, position the extractor tool to engage with the outer journal of the slip ring end bearing. Employ a second operator to support the slip ring end bracket by hand. Carefully tap the extractor tool to drive the bearing from the housing.  
**NOTE:** It may be necessary to carefully file away surplus solder from the two field winding connections on the slip ring moulding if the extractor tool will not pass over the moulding.
- 20 The rubber 'O' ring fitted in the slip ring end bracket bearing housing may remain in situ unless replacement is contemplated.
- 21 Remove the stator windings from the drive end bracket.
- 22 Remove the nut and spring washer. Prevent the rotor turning by wrapping a scrap fan belt round the pulley and retaining by hand or vice.
- 23 Remove the pulley.
- 24 Remove the fan.
- 25 Remove the flanged spacer.
- 26 Remove the key.
- 27 Unsolder two field winding connections. Pull the slip ring moulding from the shaft. This operation is necessary to prevent damage to the slip ring moulding during remove and refit of the rotor to the drive end bracket.
- 28 Using a suitable press remove the rotor from the drive end bracket.  
**CAUTION:** Do not attempt to remove the rotor by applying hammer blows to the shaft end. Such action may burr over and damage the thread.
- 29 Remove the thin spacer from the rotor shaft.
- 30 Remove three screws. Remove the plate.
- 31 Remove the rubber ring.
- 32 Press the bearing from the drive end bracket.



## Reassembling

- 33 Press the bearing into the drive and end bracket.
- 34 Position the rubber ring.
- 35 Position the plate with the counter-sinks uppermost. Secure with three screws.
- 36 Fit the thin spacer to the rotor shaft.
- 37 Using a suitable press, the flanged spacer and a suitable tube, fit the rotor to the drive end bracket by applying pressure to the bearing inner journal. **CAUTION:** Do not use the drive end bracket as a support while fitting the rotor.
- 38 Push the slip ring moulding onto the shaft. Ensure that the moulding tongue engages correctly in the shaft slot. Solder two field winding connections.
- 39 Fit the key.
- 40 Fit the flanged spacer with the reduced diameter against the bearing inner journal.
- 41 Fit the fan with the blades adjacent to the drive end bracket.
- 42 Fit the pulley with the boss against the fan.
- 43 Fit the spring washer and nut. Prevent the rotor turning by wrapping a scrap fan belt round the pulley and retaining by hand or vice. Torque load the nut to 30 to 36 lbf ft (4.2 to 4.9 kgf m).
- 44 Position the stator windings to the drive end bracket. Align the scribe lines made at operation 15 above.
- 45 Ensure that the rubber 'O' ring is fitted correctly in the slip ring end bracket bearing housing.
- 46 Fit the slip ring end bracket by carefully pushing the bearing into the housing. Align the scribe lines made at operation 15 above.
- 47 Fit three side bolts with spring washers under the bolt heads. Secure with three nuts. Tighten evenly.
- 48 Position the rectifier pack.
- 49 Fit three screws, washers and spring washers.
- 50 Fit the earth strap screw and spring washer.
- 51 Fit three pozidrive screws.

- 52 If necessary attach the regulator to the brushbox as follows—  
Position the spacer. Position the regulator. Bend down the contact strap. Fit the screw to secure the regulator. Fit the screw to secure one wire eyelet.
- 53 Position the brushbox, regulator and surge protection diode assembly.
- 54 Fit the screw, washer and spring washer.
- 55 Fit the screw and spring washer. Include the capacitor lug and the regulator earth wire eyelet in the assembly.
- 56 Fit the screw, washer and spring washer. Include the surge protection diode lug in the assembly.
- 57 Connect the red wire large Lucar connector.
- 58 Connect the white wire small Lucar connector.
- 59 Connect the red wire small Lucar connector.
- 60 Position the cover. Secure with two screws, washers and spring washers.

## BATTERY

Remove and refit 86.15.01

### Removing

- 1 Remove the battery leads.
- 2 Slacken two nuts. Swing the retaining assembly down.
- 3 Lift the battery from the tray.

### Refitting

- 4 Ensure that the retaining assembly is assembled in the swung down position with the hooks engaged in the vehicle body apertures.
- 5 Ensure that all leads and harness wires are outside the area of the retaining assembly.
- 6 Ensure that the rubber mat is correctly positioned.
- 7 Lift the battery onto the tray.
- 8 Swing the retaining assembly up. Tighten two nuts.
- 9 Fit the battery leads. Do not hammer the terminals to the terminal posts.
- 10 Coat the terminals with petroleum jelly 'Vaseline' to prevent corrosion.

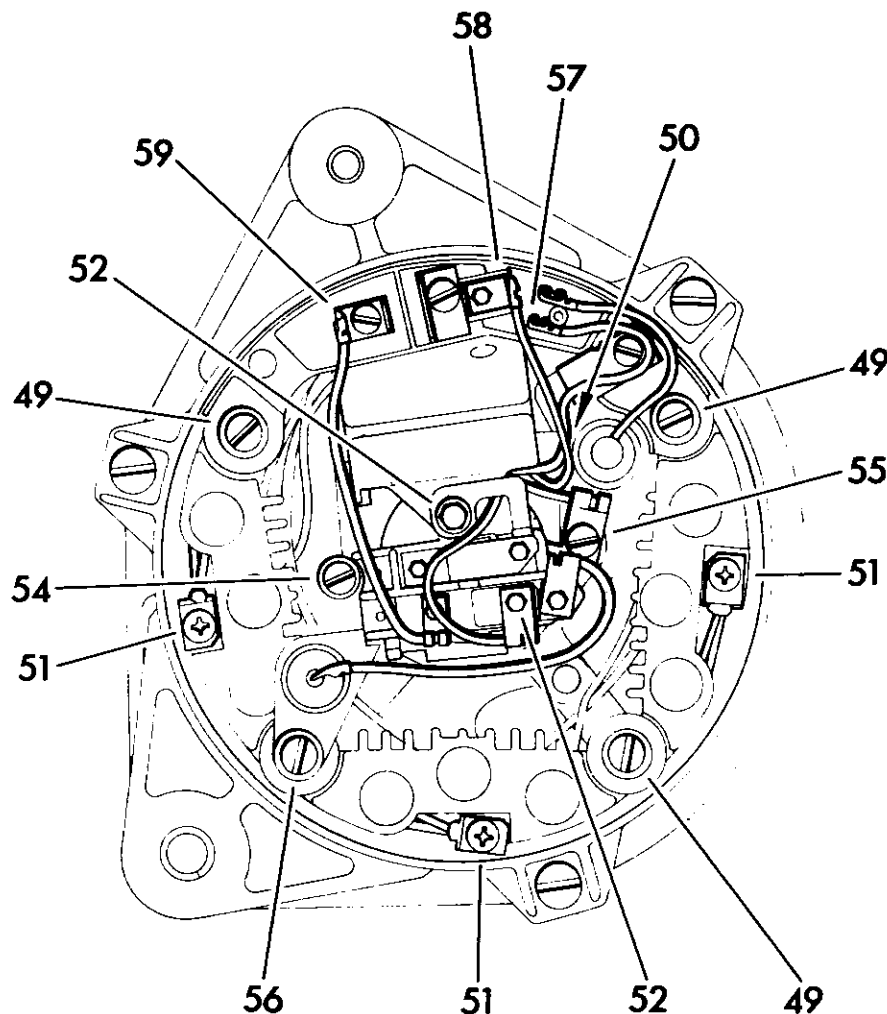

A86 069

**DRIVE RESISTOR –  
USA Markets**

<b>Data</b>	<b>86.35.00</b>
Manufacturer . . . . .	Lucas
Lucas part number . . . .	54427556
Triumph part number . . .	UKC 3908
Resistance . . . . .	10 ± 5% ohm

**Description**

This unit may be considered as a detached component of the ignition distributor amplifier. Its function is associated with the transistors in the amplifier. It is independently mounted due to its size and heat dissipating requirements.

**'OPUS ELECTRONIC IN BUILT'  
SYSTEM – USA Markets**

**Description** **86.35.00**

The 'Opus electronic in built' system consists of a conventional ignition coil and high tension circuit. The distributor contains a power transistor which manages the current flow through the ignition coil primary winding.

Distributor – deleted are the conventional cam, contacts and capacitor. These are replaced by an oscillator, timing rotor, pick up and amplifier. A conventional Lucas body, mechanical centrifugal advance and vacuum retard unit are retained.

Electronic circuit – the encapsulated oscillator supplies pulses to the pick up. The majority of these pulses are 'lost'. The timing rotor is carried on the rotating shaft and contains four ferrite rods. When one of the ferrite rods aligns with the pick up a pulse is 'caught' by the pick up and applied to the input of the encapsulated amplifier. The result is that the amplifier output switches the power transistor to the off condition.

Ignition coil and high tension circuit – the off condition of the power transistor collapses the ignition coil primary winding current. A spark occurs at the appropriate spark plug in the conventional manner.

Retard unit – the pick up is mounted on the moving plate. This assembly may be rotated through a limited angle by the vacuum retard unit. The ignition timing is thus modified by the vacuum retard unit by amending the relationship between the timing rotor and the pick up.

Drive resistor – this unit may be considered as a detached component of the amplifier. Its function is associated with the transistors in the amplifier. It is independently mounted due to its size and heat dissipating requirements.

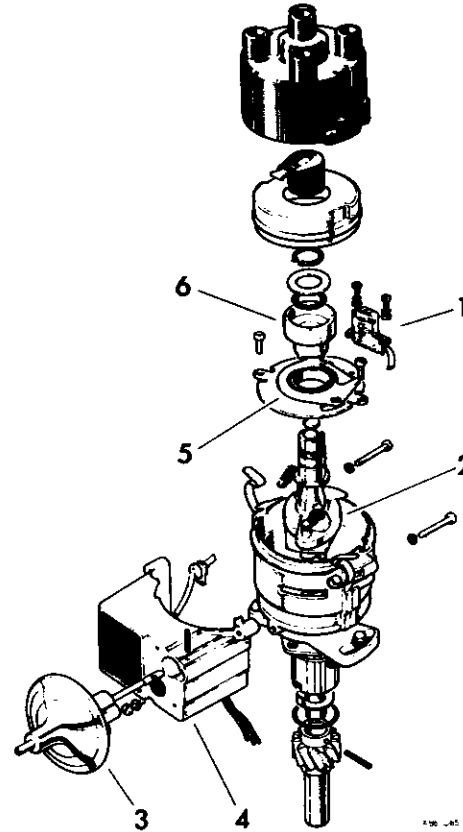

- 1 Pick up
- 2 Centrifugal advance
- 3 Retard unit
- 4 Oscillator and amplifier
- 5 Moving plate
- 6 Timing rotor

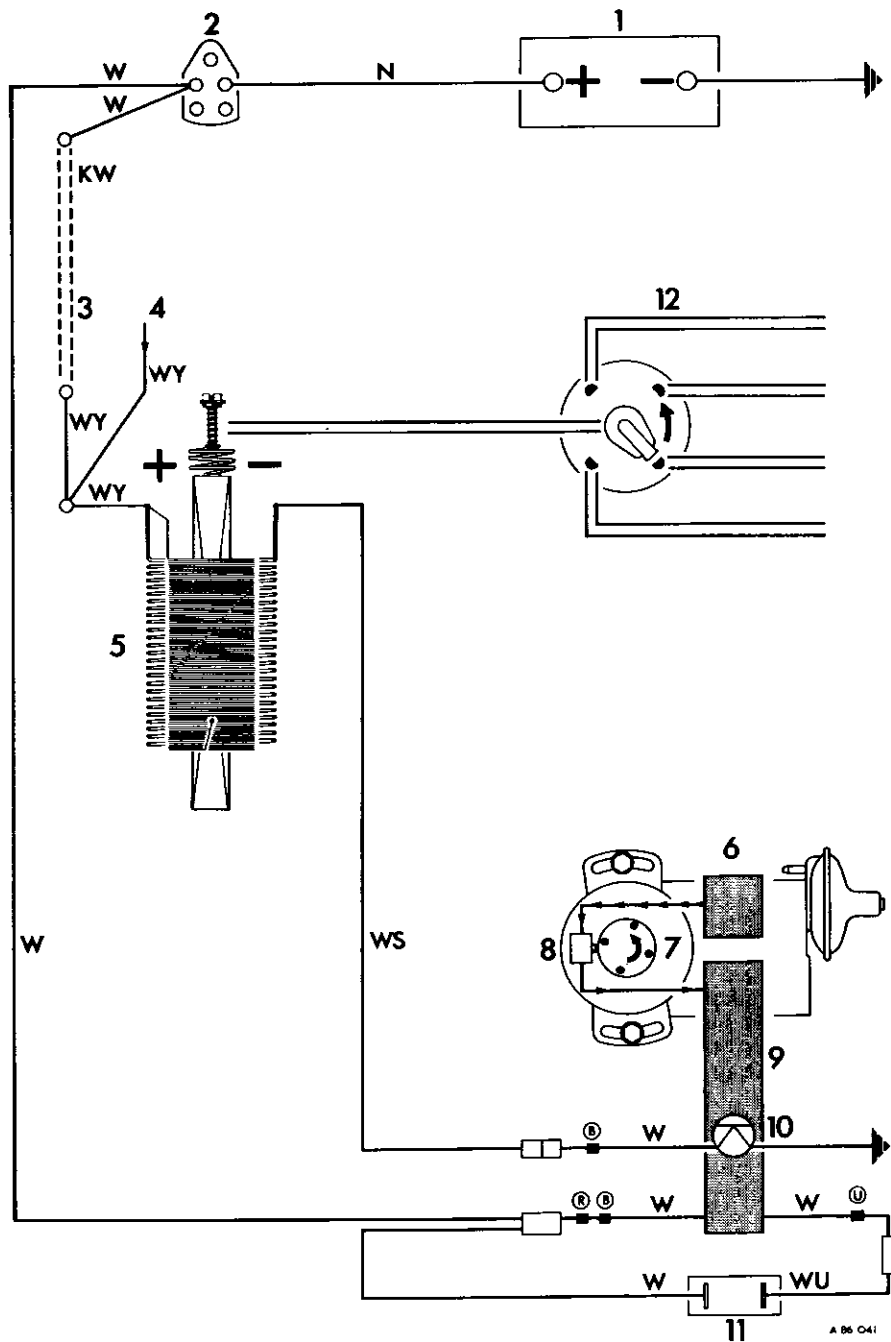

- 1 Battery
- 2 Ignition/starter switch
- 3 Ballast resistor wire
- 4 Start ignition supply from interlock starter motor relay
- 5 Ignition coil
- 6 Oscillator
- 7 Timing rotor
- 8 Pick up
- 9 Amplifier
- 10 Power transistor
- 11 Drive resistor
- 12 High tension circuit

#### Colour Code

- N Brown  
 W White  
 KW Pink/White  
 WY White/Yellow  
 WS White/Slate  
 WU White/Blue
- Ⓟ Black ident  
 Ⓡ Red ident  
 Ⓛ Blue ident

**IGNITION DISTRIBUTOR –  
UK & Europe – 2 Valve**

<b>Data</b>	
Manufacturer .....	AC Delco
Series .....	D302
Delco Remy part no. ....	7992715
Stanpart No. ....	RKC 0066
Contact gap .....	0.014 to 0.016 in
Rotation – viewed on rotor .....	Anti-clockwise
Firing angles .....	90 ± 1 degree
Dwell angle .....	39 ± 1 degree
Open angle .....	51 ± 1 degree
Moving contact spring tension .....	19 to 24 ozf
Condenser capacity .....	0.18 to 0.23 mfd
Engine firing order .....	1-3-4-2

**IGNITION DISTRIBUTOR –  
UK – 4 Valve**

<b>Data</b>	
Manufacturer .....	Lucas
Type .....	44D4
Lucas part no. ....	41655
Stanpart No. ....	RKC 3034
Contact gap .....	0.14 to 0.16 in
Rotation – viewed on rotor .....	Anti-clockwise
Firing angles .....	90 ± 1°
Dwell angle .....	51 ± 5°
Open angle .....	39 ± 5°
Moving contact spring tension .....	18 to 24 ozf
Condenser capacity .....	0.18 to 0.23 mfd
Engine firing order .....	1-3-4-2

**Centrifugal advance**

Distributor r.p.m.	Degs. distributor advance		Crankshaft r.p.m.	Degs. crankshaft advance	
	Minimum	Maximum		Minimum	Maximum
300	No advance to occur		600	No advance to occur	
500	0	1.00	1000	0	2.0
900	1.85	3.85	1800	3.7	7.7
1200	4.00	6.00	2400	8.0	12.0
1600	5.00	7.00	3200	10.0	14.0
2400	7.00	9.00	4800	14.0	18.0
3000	9.00	9.00	6000	18.0	18.0

**Centrifugal advance (check at decelerating speeds) – 4 Valve**

Distributor rev/min	Degs. distributor advance		Crankshaft rev/min	Degrees crankshaft advance	
	Minimum	Maximum		Minimum	Maximum
Below 350	No advance to occur		Below 700	No advance to occur	
450	0	1.5	900	0	3
550	0.5	2.5	1,100	1	5
800	2.75	4.75	1,600	5.5	9.5
1,000	4.5	6.5	2,000	9	13

**Vacuum advance**

Ins. of mercury vacuum	Degs. distributor advance		Degs. crankshaft advance	
	Minimum	Maximum	Minimum	Maximum
3		No advance to occur		
5	1.30	4.67	2.60	9.34
7	6.00	8.00	12.00	16.00
10	6.00	8.00	12.00	16.00
20	8.00	8.00	16.00	16.00

**Vacuum advance – 4 Valve**

In. of mercury vacuum	Degs. distributor advance		Degs. crankshaft advance	
	Minimum	Maximum	Minimum	Maximum
2	No advance to occur			
4	0	0	0	0
8	7	7	14	14

**IGNITION DISTRIBUTOR –  
USA Federal Market Vehicles only**

<b>Data</b>		<b>86.35.00</b>
Manufacturer . . . . .	Lucas	
Type . . . . .	47DE4	
Lucas part number . . . . .	41701	
Triumph part number . . . . .	TKC 3328	
System . . . . .	Opus electronic in built.	
Polarity . . . . .	Negative earth only.	
Pick-up air gap . . . . .	0.014 to 0.016 in (0.35 to 0.40 mm)	
Rotation-viewed on rotor . . . . .	Anti-clockwise	
Firing angle . . . . .	90 ± 1 degree	
Dwell angle . . . . .	70–80 degrees	
Engine firing order . . . . .	1–3–4–2	
To be used in conjunction with an external drive resistor of . . . . .	10 ± 5% ohm	

**IGNITION DISTRIBUTOR  
USA California Market Vehicles only**

<b>Data</b>		<b>86.35.00</b>
Manufacturer . . . . .	Lucas	
Type . . . . .	47 DE4	
Lucas part number . . . . .	41700	
Triumph part number . . . . .	TKC 3330	
System . . . . .	Opus electronic in built	
Polarity . . . . .	Negative earth only	
Pick-up air gap . . . . .	0.014 to 0.016 in (0.35 to 0.40 mm)	
Rotation-viewed on rotor . . . . .	Anti-clockwise	
Firing angle . . . . .	90 ± 1 degree	
Dwell angle . . . . .	70–80 degrees	
Engine firing order . . . . .	1–3–4–2	
To be used in conjunction with an external drive resistor of . . . . .	10 ± 5% ohm	

**Centrifugal advance check at decelerating speeds**

Distributor r.p.m.	Degs. distributor advance		Crankshaft r.p.m.	Degs. crankshaft advance	
	Minimum	Maximum		Minimum	Maximum
400	No advance to occur		800	No advance to occur	
650	1.0	4.0	1300	2	8
950	4.0	6.0	1900	8	12
1400	6.5	8.5	2800	13	17
1700	7.0	9.0	3400	14	18
2500	7.0	9.0	5000	14	18

**Centrifugal advance check at increasing speeds**

Distributor r.p.m.	Degs. distributor advance		Crankshaft r.p.m.	Degrees crankshaft advance	
	Minimum	Maximum		Minimum	Maximum
400	No advance to occur		800	No advance to occur	
650	1.0	4.0	1300	2	8
950	4.0	6.0	1900	8	12
1400	6.5	8.5	2800	13	17
1700	7.0	9.0	3400	14	18
2500	7.0	9.0	5000	14	18

**Retard Unit**

Ins. of mercury vacuum	Degs. distributor retard		Degs. crankshaft retard	
	Minimum	Maximum	Minimum	Maximum
3	No retard to occur			
11	5	7	10	14
15	5	7	10	14

Check first with 11 in Hg. Increase to 15 in Hg  
Finally decrease to 3 in Hg.

**SPARK PLUG – 2 Valve**

Remove, clean, adjust and refit 86.35.01

- 1 Remove the ignition high tension lead from the plug.
- 2 Unscrew the plug from the engine, using a special plug spanner or a box-type spanner.
- 3 Wipe clean the ceramic body of the plug.
- 4 Visually check the plug body for cracks, and renew the plug if any cracks are present.
- 5 Unscrew the end terminal cap from the plug.
- 6 Clean the plug terminal threads with a wire brush.
- 7 Clean the cap threads using a low pressure air line.
- 8 Screw the end terminal cap firmly into position on the plug.
- 9 Clean the electrode area and the plug threads with a wire brush or sand blasting machine.
- 10 Visually check the electrode for damage, and renew the plug if there are any signs of damage.
- 11 Check the electrode gap, which if correct will just allow 0.025 in (0.64 mm) feeler gauge to slide slowly between the electrodes under light pressure.  
If adjustment is necessary
- 12 a Using a suitable tool, carefully move the side electrode.  
b Check the gap, repeat this procedure until the gap is correct.
- 13 Refit the plug to the engine and tighten to the correct torque.
- 14 Refit the high tension lead to the plug.

**SPARK PLUG – 2 Valve**

Remove and refit 86.35.02

**Removing**

- 1 Remove the ignition high tension lead from the plug.
- 2 Unscrew the plug from the engine, using a special plug spanner or a suitable box spanner.
- 3 Discard the plug.

**Refitting**

- 4 Visually check the new plug for damage to the body and electrodes; discard the plug if there are any signs of damage.
- 5 Check the electrode gap on the new plug which, when correct, will just allow a 0.025 in (0.64 mm) feeler gauge to slide slowly between the electrodes under light pressure.  
If adjustment is necessary, using a suitable tool, carefully move the side electrode. Re-check the gap and repeat this procedure until the gap is correct.
- 6 Fit the new plug to the engine.
- 7 Tighten the plug to the correct torque.
- 8 Refit the high tension lead to the plug.

**SPARK PLUG – 4 Valve**

Remove and refit 86.35.02

**Tool:** S 357A plug spanner with rubber insert to hold spark plug. Supplied in vehicle tool kit.

**Removing**

- 1 Pull off the high tension lead, including the rubber moulding.
- 2 Locate the spanner to the spark plug.
- 3 Unscrew the spark plug.
- 4 Withdraw the spark plug and spanner together from the engine spark plug tube.
- 5 Pull the spark plug from the spanner.

**Refitting**

- 6 Locate the spark plug to the spanner.
- 7 Insert the spark plug and spanner together into the engine spark plug tube.
- 8 Screw in the spark plug. Torque load to 6 to 8 lbf ft (0.8 to 1.1 kgf m).  
**NOTE:** No gasket is fitted to the spark plug.  
The cylinder head threads and tapered seat are aluminium alloy. Do not overtighten, otherwise great difficulty will be experienced when the plug is next removed and damage may be caused to the cylinder head.  
The spark plug with a gasket on a conventional Triumph engine is torque loaded to 14 to 20 lbf ft (1.9 to 2.8 kgf m). The above requirement is approximately half this figure.
- 9 Pull the spanner from the spark plug.
- 10 Push on the high tension lead, including the rubber moulding to engage the connector to the spark plug terminal.

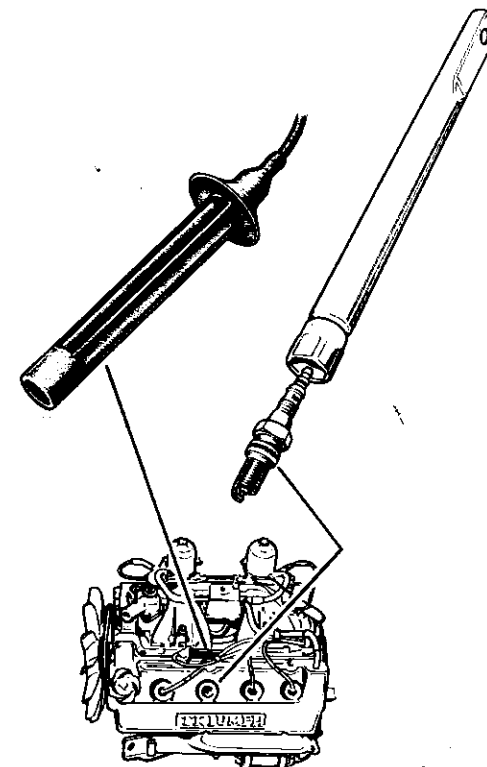

## IGNITION DISTRIBUTOR – UK & Europe – 2 Valve

Contact assembly –  
remove and refit 86.35.13

### Remove

- 1 Remove the fresh air duct, see 80.15.31.
- 2 Pull the 'king' high tension lead from the distributor cover.
- 3 Remove the distributor cover and swing to rest across the camshaft cover.
- 4 Remove two screws and spring washers. Lift off the rotor.
- 5 Push the moving contact spring away from the terminal post and slip two wire eyelets along the post to release.
- 6 If necessary rotate the crankshaft to position the weights for the best access to the contacts.  
**NOTE:** The screws are cross headed to provide a choice of screwdriver position.
- 7 Remove two cross headed screws and spring washers.
- 8 Lift out the contact assembly.

### Refit

- 9 Wipe preservative from the new contact faces.
- 10 Reverse 5 to 8.
- 11 Adjust contact gap, see 86.35.14.

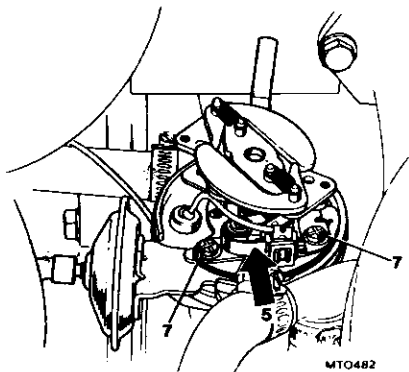

## IGNITION DISTRIBUTOR – 4 Valve

Contact assembly –  
remove and refit 86.35.13

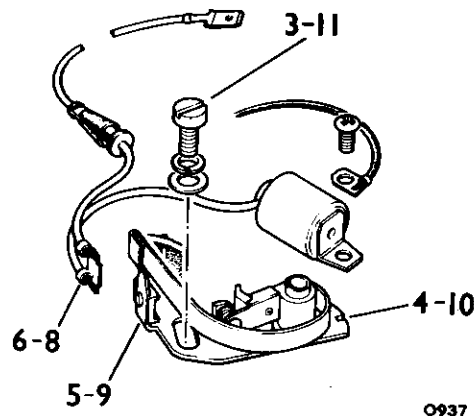

### Removing

- 1 Remove the cover and rotor.
- 2 Lift off the plastic anti-flash cover.
- 3 Remove the lock screw, spring washer and washer.
- 4 Lift out the Quikafit contact assembly.
- 5 Disengage the contact spring from the insulation pad.
- 6 Unclip the terminal plate from the contact spring.

### Refitting

- 7 Wipe preservative from the new contact faces.
- 8 Clip the terminal plate to the contact spring.
- 9 Engage the contact spring to the insulation pad.
- 10 Position the Quikafit contact assembly.
- 11 Fit the lock screw, spring washer and washer.
- 12 Adjust the contact gap, see 86.35.14.

## IGNITION DISTRIBUTOR – UK & Europe – 2 Valve

Contact gap – adjust 86.35.14

- 1 Remove the fresh air duct, see 80.15.31.
- 2 Pull the 'king' high tension lead from the distributor cover.
- 3 Remove the distributor cover and swing to rest across the camshaft cover.
- 4 Remove two screws and spring washers. Lift off the rotor.
- 5 Rotate the crankshaft to position the contact heel on a cam peak and position the weights for the best access to the contacts.
- 6 If the contact gap is correct a 0.015 in (0.38 mm) feeler gauge will fit between the contacts.
- 7 If the gap is correct operations 8 to 11 may be ignored.
- 8 Slacken two cross headed screws.
- 9 Move the fixed contact about the pivot to adjust the gap. This may be facilitated by inserting a screwdriver in the slots and twisting to position the fixed contact.
- 10 Tighten two cross headed screws.
- 11 Check that the correct gap has been maintained.
- 12 Reverse 1 to 4.

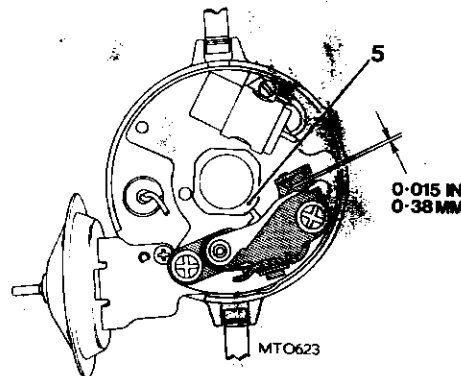

## IGNITION DISTRIBUTOR – 4 Valve

Contact gap – adjust 86.35.14

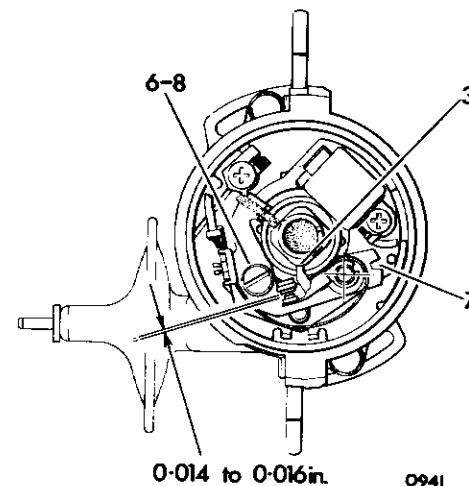

- 1 Remove the cover and rotor.
- 2 Lift off the plastic anti-flash cover.
- 3 Rotate the crankshaft to position the contact heel on a cam peak.
- 4 If the contact gap is correct a 0.014 to 0.016 in (0.36 to 0.41 mm) feeler gauge will just slide between the contacts.
- 5 When the contact gap is correct, operations 6 to 9 may be ignored.
- 6 If a correction is required, slacken the lock screw.
- 7 Move the fixed contact about the pivot to adjust the gap. This may be facilitated by inserting a screwdriver between the slot and the pip as shown and twisting to position the fixed contact.
- 8 Tighten the lock screw.
- 9 Check that the correct gap has been maintained.

## IGNITION DISTRIBUTOR – UK & Europe – 2 Valve

### Ignition timing – adjust 86.35.15

If the engine can be run adjust dynamically as follows. If the engine cannot be run adjust statically as follows:

#### Dynamic

- 1 Remove the fresh air duct, see 80.15.31.
- 2 Pull off the advance unit pipe.
- 3 Connect a tachometer to the engine as instructed by the manufacturer.  
**NOTE:** The vehicle instrument panel tachometer may be used if no other instrument is available.
- 4 Connect a timing light as instructed by the manufacturer. The engine is timed on number one cylinder which is at the front of the engine.
- 5 Run the engine.
- 6 Position the timing light to illuminate the crankshaft pulley and timing cover scale.
- 7 Hold the speed at each of the engine r.p.m. indicated. The ignition timing should be as stated.

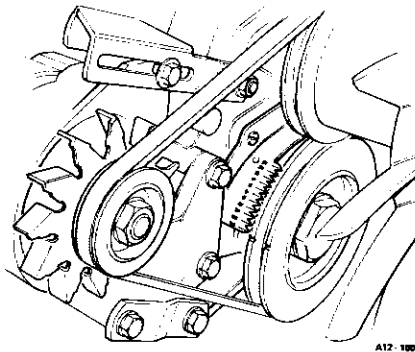

A12-100

Engine r.p.m.	Static timing	Centrifugal advance –mean	Ignition timing B.T.D.C.
1000		1.0	11.0
1800	10 degs.	5.7	15.7
2400	B.T.D.C.	10.0	20.0

- 8 Stop the engine.
- 9 If the ignition timing is correct operations 10 to 13 may be ignored.
- 10 Use service tool S349 to slacken two distributor mounting bolts.
- 11 Rotate the distributor body slightly clockwise to advance the timing or anti-clockwise to retard the timing.
- 12 Tighten two distributor mounting bolts.
- 13 Repeat operation 5 onwards.
- 14 Remove the timing light.
- 15 Remove the tachometer.
- 16 Push on the advance unit pipe.
- 17 Fit the fresh air duct, see 80.15.31.

#### Static

- 18 Isolate the battery.
- 19 Disconnect the distributor low tension fly lead from the harness.
- 20 Provide a test lamp circuit as shown.
- 21 Rotate the crankshaft in the engine run direction to bring the crankshaft pulley notch to the start of the timing cover scale. The test lamp should now be illuminated.
- 22 Carefully rotate the crankshaft further until the lamp just goes out.
- 23 If the timing is correct the pulley notch will be aligned with the 10 degree BEFORE on the scale.
- 24 If the ignition timing is correct operations 25 to 30 may be ignored.
- 25 Remove the fresh air duct, see 80.15.31.
- 26 Use service tool S349 to slacken two distributor mounting bolts.
- 27 Rotate the crankshaft in the engine run direction to align the pulley notch with the 10 degree BEFORE on the scale.
- 28 Rotate the distributor body anti-clockwise past the test lamp illumination position. Carefully rotate clockwise until the lamp just goes out.
- 29 Tighten two distributor mounting bolts.
- 30 Repeat operation 21 onwards.
- 31 Remove the test lamp circuit.
- 32 Connect the distributor low tension fly lead to the harness white/slate wire.
- 33 Fit the fresh air duct, see 80.15.31.
- 34 Connect the battery.

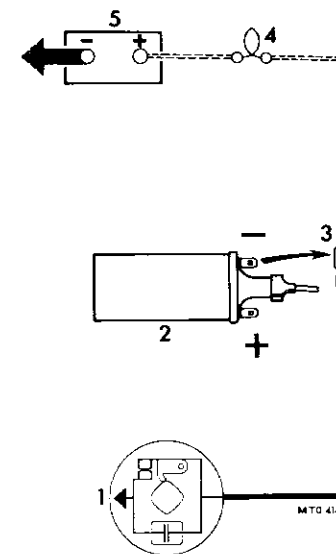

- 1 Distributor – diagrammatic layout.
- 2 Ignition coil.
- 3 Distributor fly lead removed from coil.
- 4 Test lamp – 12 volt.
- 5 Vehicle battery.

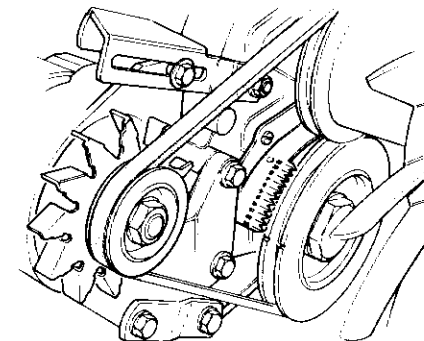

A12-100



## IGNITION DISTRIBUTOR –

### 4 Valve

Ignition timing – adjust 86.35.15

#### Static

- 1 Adjust the contact gap, see 86.35.14.
- 2 Disconnect the distributor low tension fly lead from the floating connection.
- 3 Provide a test circuit as shown.
- 4 Rotate the crankshaft in engine run direction to approximately align the mark on the pulley with the 24 degree BEFORE on the scale. The test lamp should now be illuminated.
- 5 Carefully rotate the crankshaft further until the lamp just goes out.

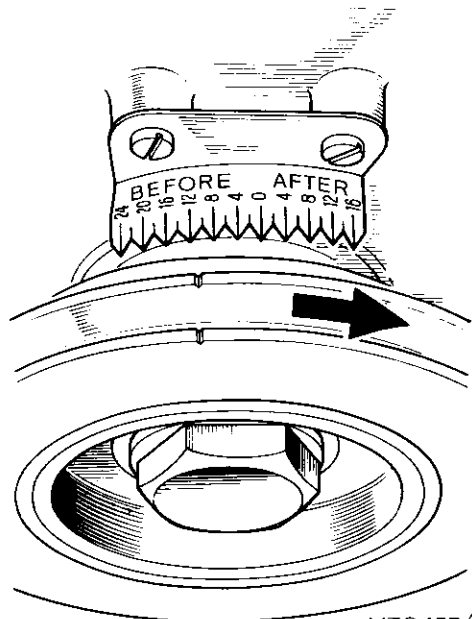

MTO457/1

- 6 If the timing is correct, the mark on the pulley will be aligned with the 10 degree BEFORE on the scale. Rotate
- 7 When the timing is correct, operations 8 to 9 may be ignored.
- 8 If a correction is required, slacken the two distributor mounting bolts. Align the mark on the pulley with the 10 degree BEFORE on the scale. Rotate the distributor body anti-clockwise past the test lamp illumination

position. Carefully rotate clockwise until the lamp just goes out. Tighten the two mounting bolts with the unit in this position.

- 9 Repeat operation 4 onwards.

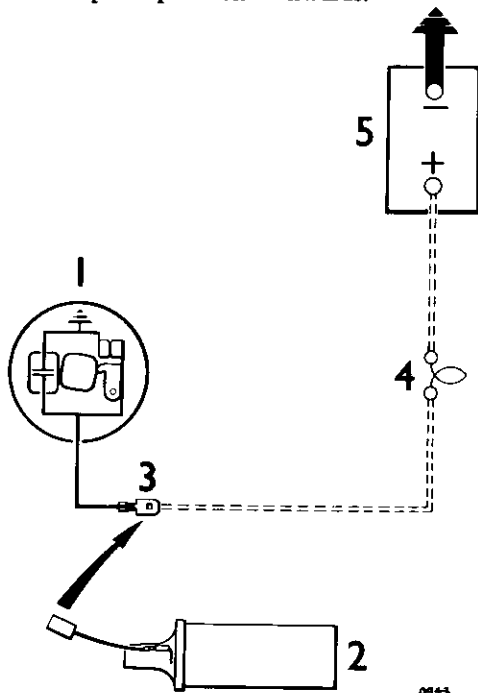

- 1 Distributor – diagrammatic layout
- 2 Ignition coil
- 3 Distributor fly lead removed from coil
- 4 Test lamp – 12 volt
- 5 Vehicle battery

## IGNITION DISTRIBUTOR – USA & Canada

Ignition timing – adjust 86.35.15

The 'Opus electronic in-built' ignition system provides a beneficial long dwell period with a short open period. For this reason a static adjustment using a test lamp is not practicable. The test lamp would only flicker and would not provide an exact firing position.

If the engine can be run adjust dynamically as follows. If the engine cannot be run, adjust statically as follows.

#### Dynamic

- 1 Connect a tachometer to the engine as instructed by the manufacturer.  
**NOTE:** The vehicle instrument panel tachometer may be used if no other instrument is available.
- 2 Connect a timing light as instructed by the manufacturer. The engine is timed on number one cylinder which is at the front of the engine.
- 3 Ensure that the retard unit pipe is connected – Canadian and California specification vehicles only.
- 4 Run the engine.
- 5 Position the timing light to illuminate the crankshaft pulley and timing cover scale.

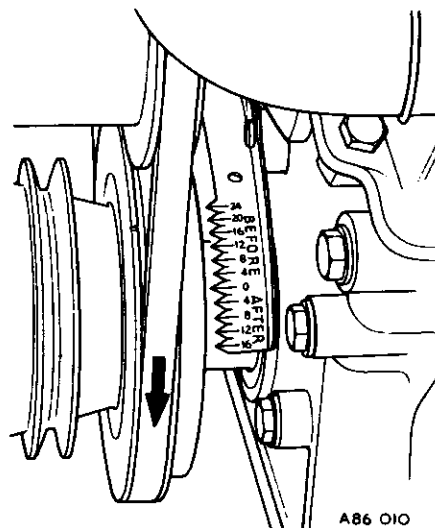

A86 O10

- 6 Hold the speed at 700 to 900 rev/min. Nominal 800 rev/min.
- 7 The ignition timing should now be 2° A.T.D.C. – Canadian and California specification vehicles only, and 10° B.T.D.C. Federal specification vehicles.
- 8 If a correction is required, perform operations 9 to 13.
- 9 Stop the engine.
- 10 Use Service tool S 349 to slacken two distributor mounting bolts.
- 11 Rotate the distributor body slightly clockwise to advance the timing, or anti-clockwise to retard the timing.

- 12 Tighten two distributor mounting bolts.
- 13 Repeat operation 4 onwards.

#### Static

- 14 Isolate the battery.
- 15 Rotate the crankshaft in the engine run direction to align the mark on the pulley with the 10° B.T.D.C. on the timing cover scale.
- 16 Remove the distributor cover.
- 17 Pull off the rotor.
- 18 Remove the plastic anti-flash cover.
- 19 Inspect the relationship of the pick-up to the nearest ferrite rod on the timing rotor. This should be positioned as shown.

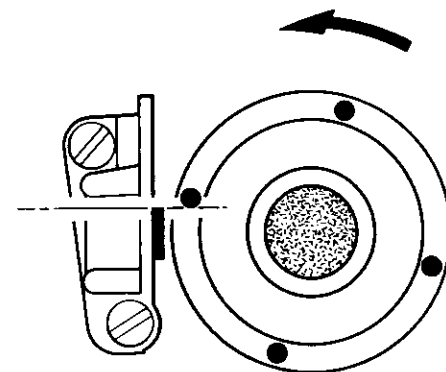

A86 O63

- 20 If a correction is required, perform operations 21 to 23.
- 21 Use Service tool S 349 to slacken two distributor mounting bolts.
- 22 Rotate the distributor body as required to achieve the position shown.
- 23 Tighten two distributor mounting bolts.
- 24 Fit the plastic anti-flash cover with the two recesses positioned adjacent to the clips.
- 25 Push on the rotor.
- 26 Fit the cover.
- 27 Connect the battery.
- 28 When the engine can be run, adjust dynamically as detailed above.

**IGNITION DISTRIBUTOR –  
UK & Europe – 2 Valve****Lubrication 86.35.18**

- 1 Remove the fresh air duct, see 80.15.31.
- 2 Pull the 'king' high tension lead from the distributor cover.
- 3 Remove the distributor cover and swing to rest across the camshaft cover.
- 4 Remove two screws and spring washers. Lift off the rotor.
- 5 Squeeze the two sides of the cam lubrication post together and withdraw the post.
- 6 Remove the sponge from the post.
- 7 Work on amount of Shell 'Alvonia No. 2' grease or equivalent into the sponge.
- 8 Fit the sponge to the post.
- 9 Squeeze the two sides of the post together and insert the post. Ensure that the curved base surface faces outwards.
- 10 Inject a few drops of engine oil through the OIL hole to lubricate the top bearing.
- 11 Apply one drop of engine oil to each weight pivot post and each 'cam action' position.
- 12 Reverse 1 to 4.

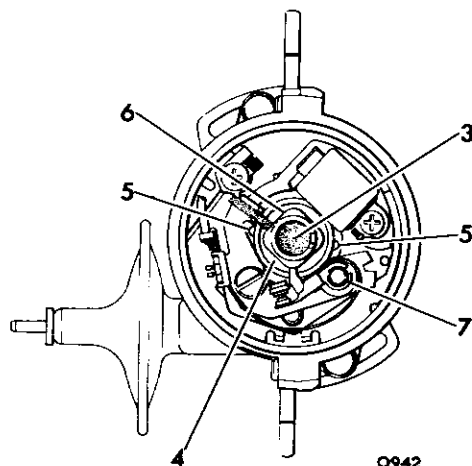
**IGNITION DISTRIBUTOR –  
4 Valve****Lubrication 86.35.18**

- 1 Remove the cover and rotor.
- 2 Lift off the plastic anti-flash cover.
- 3 Apply a few drops of engine oil to the felt pad to lubricate the cam spindle bearing.
- 4 Inject a few drops of engine oil through the apertures to lubricate the centrifugal timing control.
- 5 Apply one drop of engine oil to each of the two lubrication apertures of the contact plate bearing.
- 6 Lightly grease the cam with Shell Retinax A or equivalent.
- 7 If the moving contact is removed from the post, lightly grease the post with Shell Retinax A or equivalent.

**IGNITION DISTRIBUTOR –  
USA & Canada****Lubrication 86.35.18**

- 1 Remove the fresh air duct, see 80.15.31.
- 2 Remove the cover.
- 3 Pull off the rotor.
- 4 Remove the plastic anti-flash cover.
- 5 Apply a few drops of engine oil to the felt pad to lubricate the rotor carrier bearing.

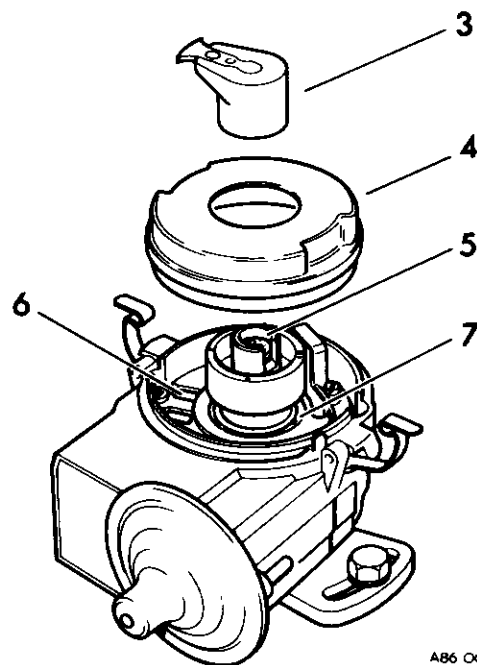

- 6 Inject a few drops of engine oil through the apertures to lubricate the centrifugal timing control.
- 7 Apply one drop of engine oil to each of the two lubrication apertures of the moving plate bearing.

## IGNITION DISTRIBUTOR – UK & Europe – 2 Valve

Remove and refit 86.35.20

### Removing

- 1 Remove the fresh air duct, see 80.15.31.
- 2 Pull the 'king' high tension lead from the distributor cover.
- 3 Remove the distributor cover and swing to rest across the camshaft cover
- 4 To assist the refit rotate the crankshaft in the engine run direction to bring number one piston to T.D.C. on the firing stroke. This is indicated when the rotor is pointing approximately towards the rear manifold mounting bolt as shown and the mark on the pulley is aligned with the 0 degree on the timing cover scale.
- 5 Pull off the advance unit pipe.
- 6 Disconnect the distributor low tension fly lead from the harness.
- 7 Use service tool S349 to remove two distributor mounting bolts, spring washers and washers.
- 8 Carefully withdraw and manoeuvre the distributor from the block.

### Refitting

- 9 Ensure that number one piston is at T.D.C. on the firing stroke and the mark on the pulley is aligned with the 0 degree on the timing cover scale.
- 10 Carefully manoeuvre and insert the distributor into the block with the vacuum unit facing exactly rearwards. Engage the drive gear so that the rotor is finally pointing approximately towards the rear manifold mounting bolt as shown.
- 11 Fit two distributor mounting bolts, spring washers and washers.
- 12 Connect the distributor low tension fly lead to the harness white/slate wire.
- 13 Push on the advance unit pipe.
- 14 Fit the distributor cover.
- 15 Push the 'king' high tension lead onto the distributor cover.
- 16 Adjust ignition timing, see 86.35.15.
- 17 Fit the fresh air duct, see 80.15.31.

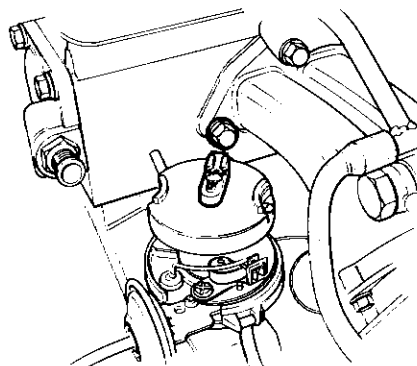

A12-90

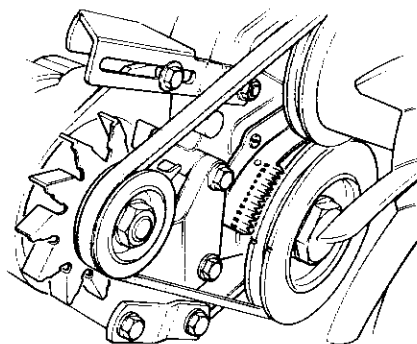

A12-108

## IGNITION DISTRIBUTOR – 4 Valve

Remove and refit 86.35.20

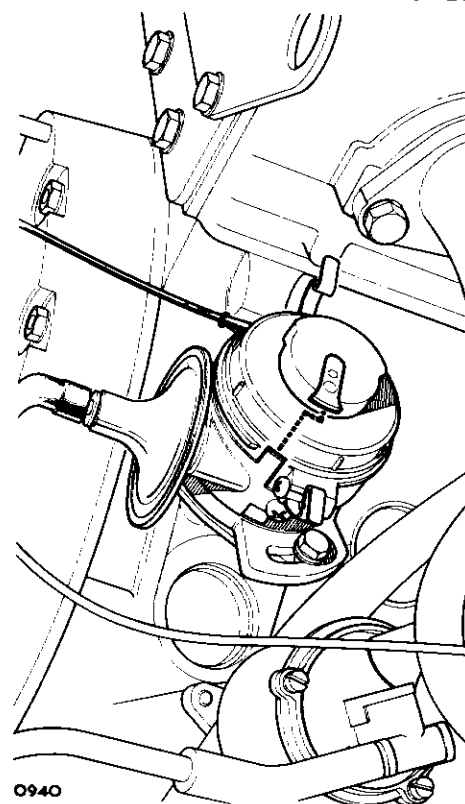

O940

### Removing

- 1 Disconnect the distributor low tension fly lead from the floating connection.
- 2 Pull off the vacuum timing control pipe.
- 3 Remove the distributor cover and position clear of the working area.

- 4 Remove two distributor mounting bolts, spring washers and washer.
- 5 Carefully withdraw and manoeuvre the distributor from the block.

### Refitting

- 6 Ensure that the mounting plate is correctly fitted to the block. The mounting plate is symmetrical and may be fitted either way round.
- 7 Remove No. 1 cylinder sparking plug, see 86.35.02.
- 8 Insert a suitable probe into the plug hole to indicate No. 1 piston position.
- 9 Rotate the crankshaft in the engine run direction to align the mark on the pulley with the 0 degree on the scale and bring No. 1 piston to T.D.C.
- 10 Carefully manoeuvre and insert the distributor into the block with the vacuum unit facing exactly rearwards. Engage the drive gear so that the rotor is finally pointing approximately towards the vacuum unit mounting plate projection shown. Fit two distributor mounting bolts, spring washers and washers finger-tight.
- 11 Fit No. 1 cylinder sparking plug, see 86.35.02.
- 12 Push on the vacuum timing control pipe.
- 13 Adjust ignition timing, see 86.35.15.

## IGNITION DISTRIBUTOR – USA & Canada

Remove and refit 86.35.20

**CAUTION:** Do not connect the ignition distributor wires listed below direct to the battery positive supply –  
White wire with Blue indent.  
White wire with Black indent.

### Removing

- 1 Isolate the battery.
- 2 Remove the fresh air duct. 80.15.31.
- 3 Remove the distributor cover.
- 4 Pull off the retard unit pipe. – Canadian and California specification vehicles only.
- 5 Disconnect three wire connectors.
- 6 Use Service tool S349 to remove two distributor mounting bolts, spring washers and washers.
- 7 Carefully withdraw and manoeuvre the distributor from the block.

### Refitting

- 8 Ensure that the mounting plate is correctly fitted to the block. The mounting plate is symmetrical and may be fitted either way round.
- 9 Rotate the crankshaft in the engine run direction to bring number one piston to T.D.C. on the firing stroke and align the mark on the pulley with the 0 degree on the timing cover scale.
- 10 Carefully manoeuvre and insert the distributor into the block with the vacuum unit facing exactly rearwards. Engage the drive gear so that the rotor is finally pointing approximately towards the rear manifold mounting bolt as shown.
- 11 Fit two distributor mounting bolts, spring washers and washers.

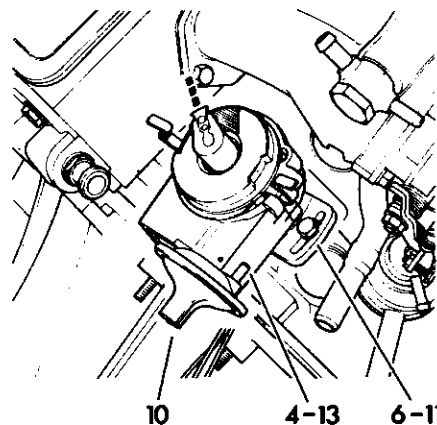

A86 009

- 12 Connect three wire connections as shown on illustration 86.35.00 Sheet 5.
- 13 Push on the retard unit pipe. – Canadian and California specification vehicles only.
- 14 Fit the distributor cover.
- 15 Connect the battery.
- 16 Adjust ignition timing. 86.35.16.
- 17 Fit the fresh air duct. 80.15.31.

## IGNITION DISTRIBUTOR – UK & Europe – 2 Valve

Overhaul 86.35.26

### Dismantling

- 1 Remove the cover.
- 2 Remove two screws and spring washers. Lift off the rotor.
- 3 Note the position of the two wire eyelets on the terminal post.
- 4 Push the moving contact spring away from the terminal post and slip two wire eyelets along the post to release.
- 5 Rotate the shaft to position the weights for the best access to the cross-headed screws. The screws are cross-headed to provide a choice of screwdriver position.
- 6 Remove two cross-headed screws and spring washers. Lift out the contact assembly.
- 7 Remove the screw and lift out the condenser.
- 8 Squeeze the two sides of the cam lubrication post together and withdraw the post.
- 9 Remove the sponge from the post.
- 10 Tap out the roll pin. Remove the drive gear and thrust washer.
- 11 Ensure that the shaft is burr-free. Withdraw the assembly.
- 12 Remove the special circlip and lift off the plate.
- 13 Remove two screws and lift off the earth lead and vacuum advance unit.
- 14 Carefully prise out the felt washer.
- 15 Remove the rubber grommet upwards and withdraw the wire assembly.
- 16 Remove the control springs, exercising great care not to distort the springs.
- 17 Lift off the weights.
- 18 Remove the cam unit by withdrawing down the shaft.

### Reassembling

- 19 Lubricate the shaft with engine oil. Fit the cam unit to the shaft.
- 20 Position the weights.

- 21 Fit the control springs, exercising great care not to distort the springs.
- 22 Insert the wire assembly downwards and fit the rubber grommet.
- 23 Saturate the felt washer with engine oil and position in the base recess.
- 24 Fit the vacuum advance unit. Include the earth lead tag under the appropriate screw head.
- 25 Lubricate the plate bearing with engine oil. Fit the plate and secure it with the special circlip.
- 26 Ensure that the shaft is adequately lubricated with engine oil. Insert the shaft assembly.
- 27 Fit the thrust washer and drive gear. Secure with the roll pin.
- 28 Work an amount of Shell 'Alvania No. 2' grease or equivalent into the sponge.
- 29 Fit the sponge to the post.
- 30 Squeeze the two sides of the post together and insert the post. Ensure that the curved base surface faces outwards.
- 31 Fit the condenser. Include the earth lead tag under the screw head.
- 32 Position the contact assembly. Fit two cross-headed screws and spring washers finger tight.
- 33 Push the moving contact spring away from the terminal post and slip two wire eyelets along the post to secure in the positions noted at operation 3 above.
- 34 Rotate the shaft to position the contact heel on a cam peak and position the weights for the best access to the contacts.
- 35 Move the fixed contact about the pivot to adjust the contact gap to 0.015 in (0.38 mm). This may be facilitated by inserting a screwdriver in the slots and twisting to position the fixed contact.
- 36 Tighten two cross-headed screws.
- 37 Check the correct gap has been maintained.
- 38 Apply one drop of engine oil to each weight pivot post and each 'cam action' position.
- 39 Position the rotor with correct location of the keying. Secure with two screws and spring washers.
- 40 Fit the cover.

## IGNITION DISTRIBUTOR —

### 4 Valve

Overhaul

86.35.26

This overhaul instruction is specific to Lucas distributor part number 41402. Other units may differ slightly.

#### Dismantling

- 1 Remove the contact assembly, see 86.35.13.
- 2 Withdraw the felt pad.
- 3 Remove the capacitor screw. Manoeuvre the low tension lead grommet inwards towards the centre of the unit. Remove the capacitor and low tension lead connected together.
- 4 Remove two screws and anti-vibration washers. Withdraw the vacuum advance unit.
- 5 Remove the screw to release the expandable limb. Lift out the moving plate earth lead.
- 6 Use a small screwdriver to push the expanded limb of the base plate inwards to release it from the body chamfered undercut. Lift out the plate assembly.
- 7 Tap out the drive gear pin. Remove the drive gear and thrust washer. Ensure that the shaft is burr-free and withdraw it.
- 8 Remove the distance collar.
- 9 Remove the control springs, exercising care not to distort the springs.

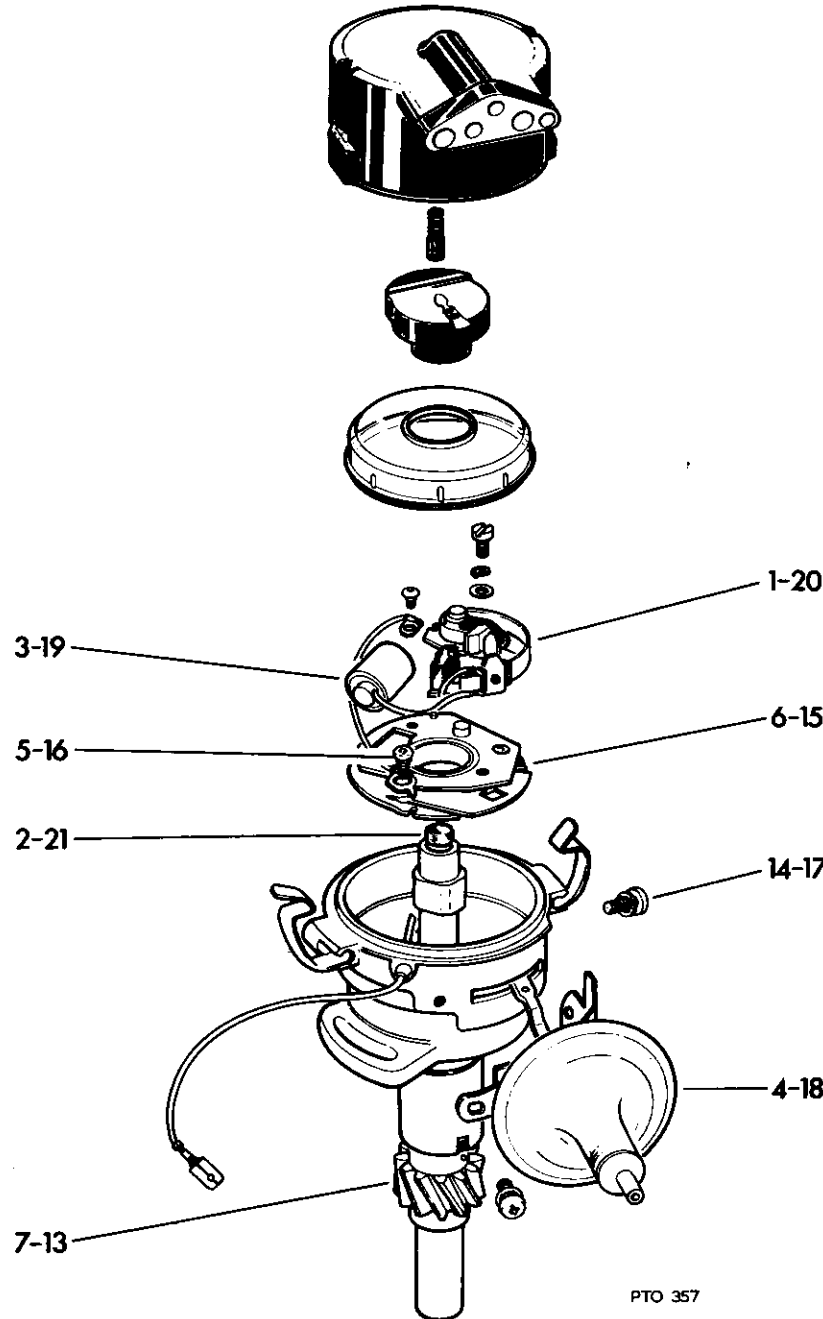

#### Reassembling

- 10 Lubricate the action plate, weight and cam assembly working surfaces with Rocol 'Molypad'.
- 11 Fit the control springs, exercising care not to distort the springs.
- 12 Fit the distance collar.
- 13 Lubricate the shaft with Rocol 'Molypad' and insert it into the body. Fit the thrust washer and drive gear. Secure with the drive gear pin.
- 14 Temporarily fit one screw and anti-vibration washer adjacent to one clip as shown. This is to facilitate operation 15 below.
- 15 Lubricate the moving plate pin with Rocol 'Molypad'. Position the plate assembly so that the two downward-facing prongs straddle the screw fitted at operation 14 above. Push the plate assembly downwards until it 'clicks' into the body chamfered undercut.
- 16 Position the moving plate earth lead tag. Fit the screw to expand the expandable limb.
- 17 Temporarily remove one screw and anti-vibration washer fitted at operation 14 above.
- 18 Lubricate the vacuum advance unit link hole with Rocol 'Molypad'. Insert the vacuum advance unit so that the moving plate pin engages correctly in the link hole. Secure first with one screw and anti-vibration washer in the round hole. Secure secondly with one screw and anti-vibration washers in the elongated hole.
- 19 Thread the low tension lead outwards through the body hole. Manoeuvre the lead grommet into position. Position the capacitor and the moving plate earth lead tag. Secure with the capacitor screw.
- 20 Fit the contact assembly, see 86.35.13.
- 21 Insert the felt pad.
- 22 Lubricate, see 86.35.18.

# IGNITION DISTRIBUTOR – USA & Canada

## Overhaul

86.35.26

### Dismantling

- 1 Remove the cover.
- 2 Pull off the rotor.
- 3 Remove the plastic anti flash cover.
- 4 Withdraw the felt pad.
- 5 Carefully remove two screws, lock washers and washers to release the pick up.
- 6 Remove two long screws and lock washers.
- 7 Hold the amplifier module in position. Remove one short screw, lock washer and washer.
- 8 Hold the distributor body in one hand and the amplifier module in the other hand. Carefully manoeuvre to unhook the retard unit link from the moving plate pin. This operation will not be visible.
- 9 Hold the distributor body and amplifier module slightly apart. Withdraw two clips.
- 10 Pull out the wire grommet. Remove the amplifier module and pick up joined together by the wires.
- 11 Tap out the retard unit pin. Withdraw the retard unit.
- 12 Using a suitable pair of small circlip pliers remove the circlip.
- 13 Remove the plain washer.
- 14 Remove the rubber 'O' ring.
- 15 Carefully withdraw the timing rotor.
- 16 Remove two screws. Lift out the base plate.
- 17 Tap out the drive gear pin. Remove the drive gear and thrust washer. Ensure that the shaft is burr free and withdraw it.
- 18 Remove the metal distance collar.
- 19 Remove the control springs, exercising care not to distort the springs.

**NOTE:** Do not attempt to dismantle the shaft and mechanism further.

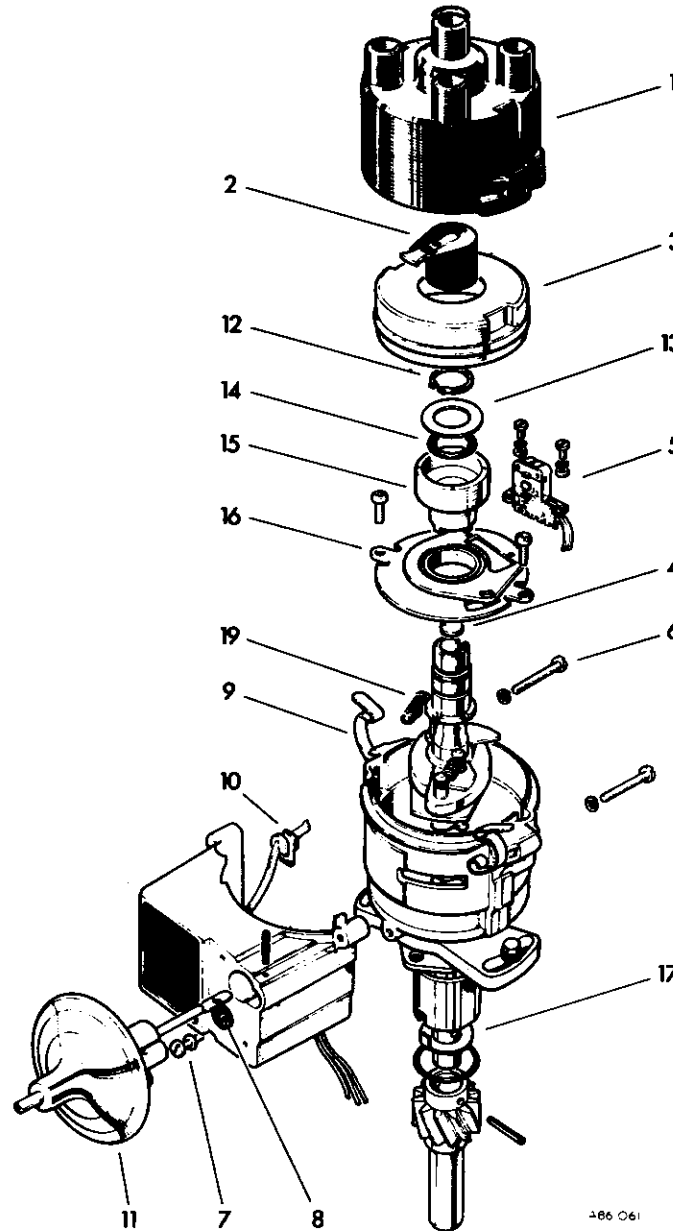

A86 061

### Reassembling

- 20 Lubricate the weight assembly working surfaces with Rocol 'Moly pad'.
- 21 Fit the control springs, exercising care not to distort the springs.
- 22 Fit the metal distance collar.
- 23 Lubricate the shaft with Rocol 'Moly pad' and insert it into the body. Fit the thrust washer and drive gear. Secure with the drive gear pin.
- 24 Lubricate the moving plate pin with Rocol 'Moly pad'. Position the base plate so that the moving plate pin is correctly positioned for the retard unit link. Secure with two screws.
- 25 Carefully insert the timing rotor. Ensure that the master projection locates correctly in the master slot.
- 26 Fit the rubber 'O' ring.
- 27 Fit the plain washer.
- 28 Fit the circlip.
- 29 Insert the retard unit. Secure with the retard unit pin.
- 30 Hold the distributor body and amplifier module slightly apart. Push in the wire grommet.
- 31 Insert two clips.
- 32 Hold the distributor body in one hand and the amplifier module in the other hand. Carefully manoeuvre and slightly rotate the moving plate to hook the retard unit link to the moving plate pin. This operation will not be visible.
- 33 Hold the amplifier module in position. Fit one short screw, lock washer and washer finger tight.
- 34 Fit two long screws and lock washers finger tight.
- 35 Ensure that the amplifier module and two wire grommets are correctly seated. Tighten three screws evenly.
- 36 Position the pick up. Carefully fit two screws, lock washers and washers finger tight.
- 37 Adjust the pick up air gap. 86.35.31.
- 38 Insert the felt pad.
- 39 Lubricate. 86.35.18.
- 40 Fit the plastic anti flash cover with the two recesses positioned adjacent to the clips.
- 41 Push on the rotor.
- 42 Fit the cover.

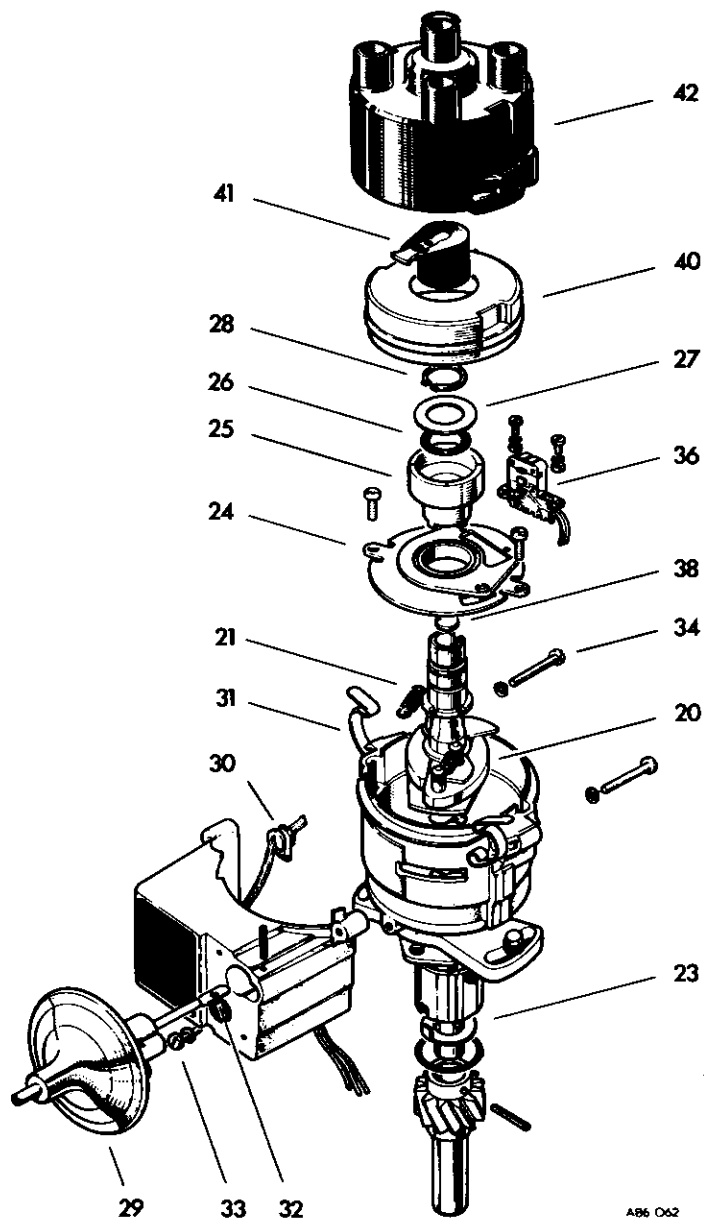

### IGNITION DISTRIBUTOR

Pick up air gap — adjust 86.35.31

**CAUTION:** Do not insert a feeler gauge into the pick up air gap when the ignition circuit is energised.

- 1 Isolate the battery.
- 2 remove the fresh air duct. 80.15.31.
- 3 Remove the cover.
- 4 Pull off the rotor.
- 5 Remove the plastic anti flash cover
- 6 If the pick up air gap is correct a 0.014 to 0.016 in (0.35 to 0.40 mm) feeler gauge will just slide between the contacts.
- 7 When the pick up air gap is correct operations 8 to 11 may be ignored.
- 8 If a correction is required slacken two screws.
- 9 Move the pick up about the pivot screw to adjust the gap.
- 10 Tighten two screws.
- 11 Check that the correct gap has been maintained.
- 12 Connect the battery.

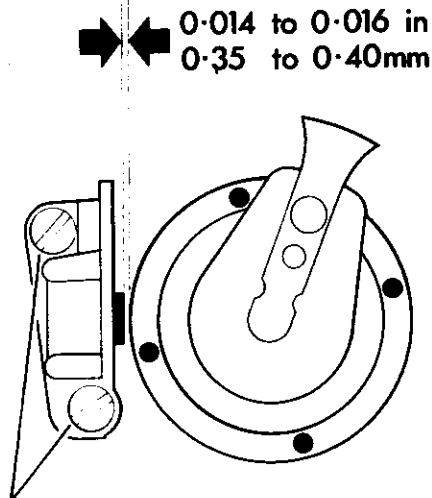

## IGNITION COIL AND BALLAST RESISTOR – All Models

### Data

#### Ignition coil

Manufacturer .....	Lucas
Type .....	15C6
Lucas part number .....	45266
Triumph part number .....	UKC 2982

Primary winding resistance ..... 1.3 to 1.45

#### Ballast resistor wire

Resistance .....	1.3 to 1.5 ohm
Wire length .....	63 in (1600 mm)
Wire colour code .....	Pink/white

### Description

This system is designed to assist engine starting under adverse conditions. A ballast resistor wire built into the harness is electrically positioned in series in the normal supply to the ignition coil. This wire causes a voltage drop in the circuit so that the 12 volt supply from the ignition switch may be employed to power the nominally rated 6 volt ignition coil.

During engine start the resistor is by-passed and the battery voltage (reduced from 12 volt by the starter motor load) is applied to the coil direct from the starter motor relay. This slight voltage overload provides an increased high tension voltage at the spark plugs.

## IGNITION COIL – All Models

Remove and refit 86.35.32

### Removing

- 1 Drive the vehicle onto a ramp.
- 2 Raise the ramp.
- 3 Locate the ignition coil mounted in the engine bay low down on the right hand side of the bulkhead as shown.
- 4 Pull up the protective cover.
- 5 Pull off the high tension lead.
- 6 Disconnect two Lucar connectors.
- 7 Remove two nuts, spring washers and washers.
- 8 Remove the drive resistor lug from the body stud. – U.S.A. spec. vehicles.
- 9 Remove the ignition coil from two body studs.

### Refitting

- 10 Reverse 1 to 9.

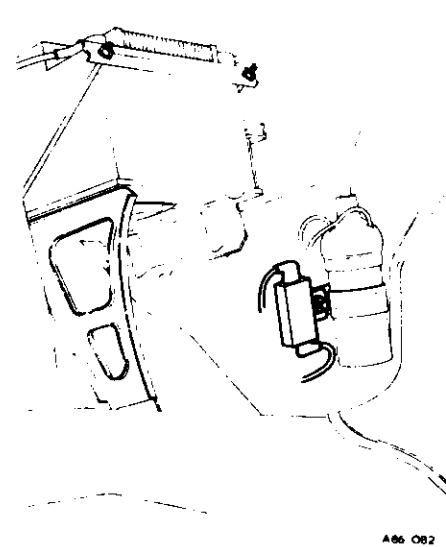

A86 082

## DRIVE RESISTOR – USA Specification Vehicles

Remove and refit 86.35.37

### Removing

- 1 Drive the vehicle onto a ramp.
- 2 Raise the ramp.
- 3 Locate the drive resistor mounted in the engine bay low down on the right hand side of the bulkhead as shown.
- 4 Disconnect two Lucar connectors.
- 5 Remove single nut, spring washer and washer.
- 6 Remove the drive resistor from the body stud.

### Refitting

- 7 Reverse 1 to 6. The Lucar connectors may be fitted either way round.

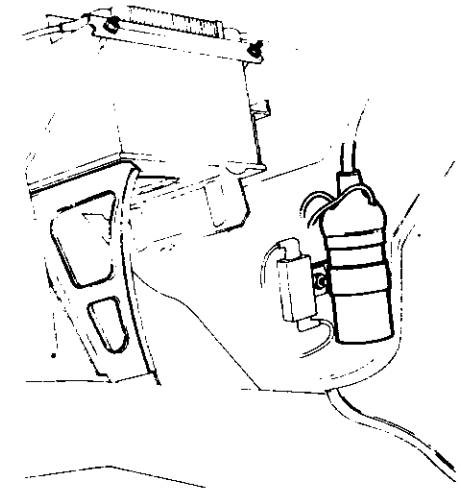

A86 081



## HEADLAMP

### Data

#### Actuator

Manufacturer .....	Lucas
Type .....	15W
Lucas part number .....	75857
Triumph part number .....	RKC 0822

Polarity .....	Negative earth only
Running current – after 60 seconds from cold with link rod disconnected from crank .....	1.5 amp.
Running speed – crank after 60 seconds from cold with link rod disconnected from crank .....	46 to 52 rev/min
Armature end-float .....	0.002 to 0.008 in (0.05 to 0.20 mm)
Brush length – new .....	0.250 in (6.35 mm)
renew if less than .....	0.187 in (4.75 mm)
Brush spring pressure – when compressed so brush bottom is aligned with brush-box slot end .....	5 to 7 ozf (140 to 200 gf)

86.40.00

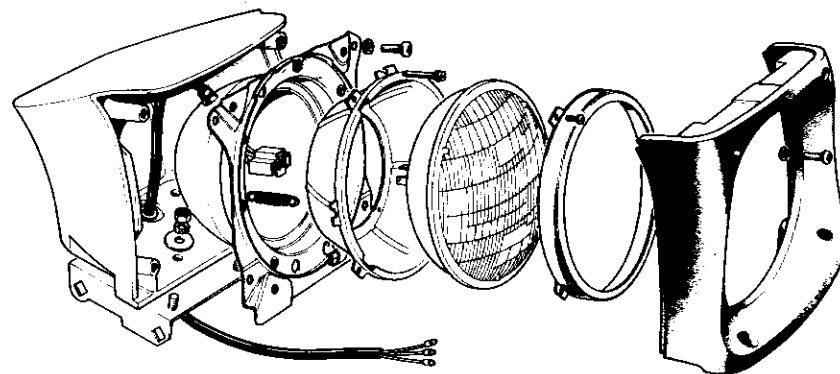

AB6 006

### Description 86.40.00

A base bracket is bolted rigidly to the vehicle body. A substantial light alloy member is hinged to the base bracket. The light alloy member is traversed from one position to the other by an electric actuator. Mounted to the light alloy member is a 'body colour' box casting which contains the headlamp.

Actuator – this consists of a permanent magnet motor and a gearbox unit which drives a single direction rotating crank arm. The gearbox unit includes a limit switch.

Action – rotation of the actuator crank arm is converted to an up and down motion of the light alloy member by a link rod. The weight of the assembly is counter-balanced by a spring.

Box casting – with the headlamp in the close position the top surface of the box casting provides the visible panel which follows the vehicle body contours. In the open position the box casting forms the visible fairing. The headlamp is a conventional Lucas seven inch housing and light unit assembly.

Hand knob – the actuator is provided with a hand knob. This may be used to open or close a headlamp during service or if an actuator should fail. Rotate only in the direction shown.

**WARNING:** Exercise care when using the hand knob. If the battery is not isolated slight rotation of the hand knob may initiate a full cycle movement. Keep all limbs clear of the mechanism to avoid personal injury.

Design – to assist manufacture and service the base bracket, light alloy member, actuator and link rod assembly is not handed. To follow the vehicle body contours the box casting is handed.

Service – special precautions must be taken to avoid scratching the visible paint surfaces of the box casting. If the headlamp assembly is removed from the vehicle onto a bench, the bench should be covered with a thick protective cloth.

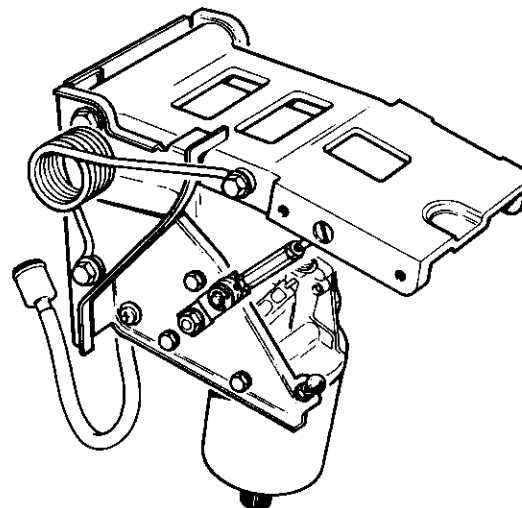

AB6 045

**HEADLAMP RUBBER BEZEL**Remove and refit **86.40.01****Removing**

- 1 Select the master light switch to raise the headlamps.
- 2 Isolate the battery to extinguish the headlamps.
- 3 Unscrew four Pozidriv screws and lock washers.
- 4 Pull the rubber bezel from the box casting.
- 5 Manoeuvre the rubber bezel downwards into the headlamp cavity. If necessary manoeuvre further downwards to remove from the vehicle. The rubber bezel may be distorted slightly to facilitate this operation.
- 6 Collect up four Pozidriv screws and lock washers.

**Refitting**

- 7 Reverse 1 to 5.

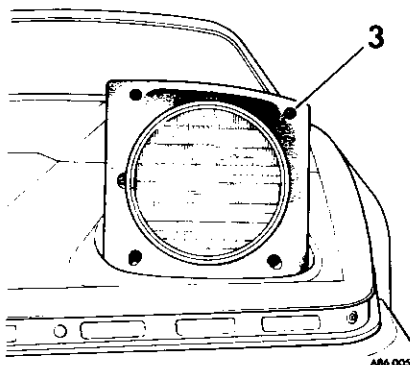
**HEADLAMP ASSEMBLY**Remove and refit **86.40.02****Removing**

- 1 Remove the rubber bezel, see 86.40.01.
- 2 To assist refitting, note the actuator harness and headlamp wire runs relative to the components.
- 3 Disconnect the actuator harness plug.
- 4 Disconnect three headlamp snap connectors.
- 5 Support the weight of the headlamp assembly. Remove four nuts, lock washers and washers. Carefully manoeuvre the headlamp assembly upwards through the body aperture.

**Refitting**

- 6 Carefully manoeuvre the headlamp assembly downwards through the body aperture. Fit four washers, lock washers and nuts.
- 7 Connect three headlamp snap connectors. Ensure that the wire runs are as noted at operation 2 above. Connect the wires as follows:  
Blue/red wire to blue/red wire  
Blue/white wire to blue/white wire  
Black wire to black wire.
- 8 Connect the actuator harness plug. Ensure that the harness run is as noted at operation 2 above.
- 9 Inspect the actuator harness and headlamp wire runs to ensure that no foul occurs while using the actuator manual thumb screw to traverse the mechanism over its full travel.
- 10 Adjust the headlamp assembly, see 86.40.16.
- 11 Refit the rubber bezel, see 86.40.01.

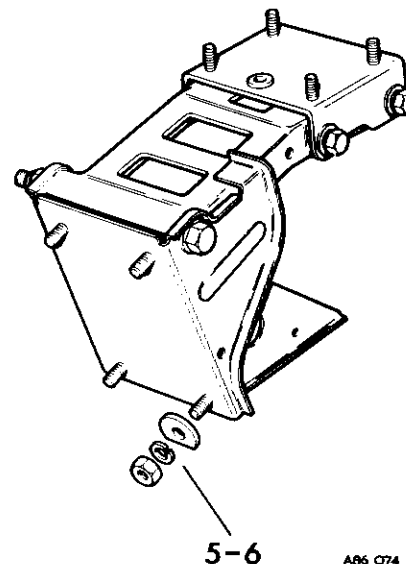
**HEADLAMP LIGHT UNIT**Remove and refit **86.40.09****Removing**

- 1 Remove the rubber bezel, see 86.40.01.
- 2 Remove three screws to release the retaining rim and light unit.
- 3 Pull the connector block from the light unit.

**Refitting**

- 4 Reverse 1 to 3.

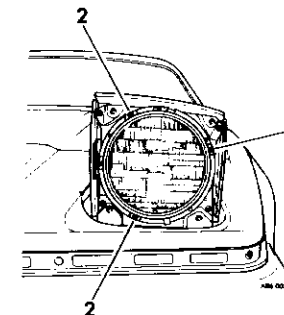
**HEADLAMP LINK ROD**Remove and refit **86.40.12**

The upper end of the link rod contains a rubber bush. This provides a measure of compliance to the link rod alignment and to the primary and secondary adjustments.

After an extended period of service wear of the upper rubber bush and the lower Oilite bush may dictate renewal of the link rod.

**Removing**

- 1 Remove the headlamp assembly, see 86.40.02.
- 2 Perform 86.40.15 operations 2 to 11.

**Refitting**

- 3 Perform 86.40.15 operations 39 to 49.
- 4 Refit the headlamp assembly, see 86.40.02.

## HEADLAMP ACTUATOR

### Remove and refit

86.40.13

#### Removing

- 1 Remove the headlamp assembly, see 86.40.02.
- 2 Safely retain the spring by rotating the actuator manual thumb screw to position the light alloy member against the metal up stop on the base bracket.
- 3 Remove the circlip and washer.
- 4 Remove the nut, lock washer, washer and screw. Remove the harness 'P' clip.
- 5 Remove three screws and lock washers.
- 6 Manoeuvre the link rod from the bush.
- 7 Remove the bush from the crank arm.
- 8 Manoeuvre the crank arm through the aperture.

#### Refitting

- 9 Manoeuvre the crank arm through the aperture.
- 10 Lubricate the bush working surfaces with engine oil.
- 11 Fit the bush to the crank arm.
- 12 Position the link rod ends in the turnbuckle so that an equal number of threads are visible at each end.
- 13 Manoeuvre the link rod to the bush. It may be necessary to rotate the manual thumb screw to position the crank arm.
- 14 Position the actuator. It may be necessary to rotate the manual thumb screw to position the crank arm. Ensure that the actuator harness is looped up between the actuator and the base bracket. Secure with three screws and lock washers.
- 15 Position the harness 'P' clip. Secure with the screw, washer, lock washer and nut.
- 16 Fit the washer and circlip.
- 17 With the headlamp assembly removed from the vehicle perform the primary adjustment and the secondary adjustment, see 86.40.16.
- 18 Refit the headlamp assembly, see 86.40.02.

## HEADLAMP ACTUATOR

### Overhaul

86.40.14

**CAUTION:** The actuator operates in a hostile environment. After overhaul or disturbing any joint the unit must be sealed as detailed in operation 33.

#### Dismantling

- 1 Remove three hexagon screws and two Pozidriv screws. Lift off the cover and gasket.
- 2 Disconnect two Lucar connectors.
- 3 Remove one hexagon screw. Lift off the limit switch and harness.
- 4 Remove the nut. Withdraw the crank arm and washer.
- 5 Ensure that the shaft is burr-free and withdraw it. Remove the dished washer.
- 6 Using a large screwdriver blade carefully prise the hand knob from the armature shaft.
- 7 Remove the thrust screw or the thrust screw and locknut as fitted.
- 8 Remove the through bolts.
- 9 Carefully withdraw the cover and armature about 0.2 in (5 mm). Continue withdrawal, allowing the brushes to drop clear of the commutator. Ensure that the two brushes are not contaminated with grease.
- 10 Pull the armature from the cover against the action of the permanent magnet.
- 11 Remove two thrust washers.  
**NOTE:** These may be on the armature shaft or in the cover bearing recess.
- 12 Remove three screws to release the brush assembly. Break the wire slot seal. Lift the assembly from the recess.

*continued*

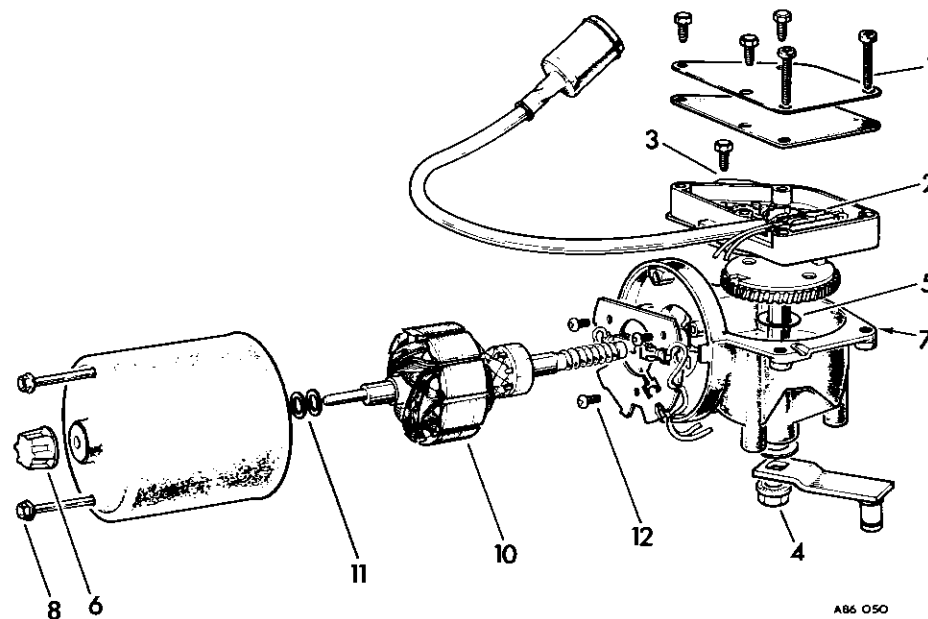

**Reassembling**

**NOTE:** The following lubricants are required during assembly:

Molybdenum di-sulphide oil.

Shell Turbo 41 oil.

Ragoline Listate grease.

- 13 Position the brush assembly. Insert the wires in the slot. Secure with three screws.
- 14 Lubricate two thrust washers with Molybdenum di-sulphide oil.
- 15 Fit two thrust washers into the cover bearing recess.
- 16 Lubricate the cover bearing with Shell Turbo 41 oil
- 17 Position the armature to the cover against the action of the permanent magnet. Ensure that the two thrust washers remain in position during this operation.
- 18 Lubricate the self-aligning bearing with Shell Turbo 41 oil.
- 19 Carefully insert the armature shaft through the bearing. Ensure that the brushes are not contaminated with lubricant. Push the two brushes back to clear the commutator.
- 20 Seat the cover against the gearbox. Turn the cover to align the marks shown. Fit the through bolts.
- 21 Fit the thrust screw or the thrust screw and locknut as fitted.
- 22 If a non-adjustable thrust screw is fitted check the armature end-float as follows:

Position a feeler gauge between the armature shaft and the thrust screw. Push the armature towards the cover. End-float should be 0.002 to 0.008 in. In the unlikely event of adjustment being required end-float may be increased by fitting shim washer/washers under the thrust screw head or reduced by mounting the thrust screw in a lathe and removing metal from the underside of the head.

- 23 If an adjustable thrust screw and locknut is fitted adjust the armature end-float as follows:  
Slacken the locknut. Screw the thrust screw in until resistance is felt. Screw the thrust screw out a quarter of a turn – maintain in this position and tighten the locknut.

- 24 Push the hand knob onto the armature shaft.
- 25 Lubricate the final gear bushes with Shell Turbo 41 oil.
- 26 Fit the dished washer with its concave surface facing the final gear. Insert the shaft.
- 27 Fit the washer. Fit the crank arm. Ensure that the relationship of the crank arm to the final gear cam is as shown. Secure with the nut.
- 28 Lubricate the final gear cam with Ragoline Listate grease.
- 29 Position the limit switch and harness. Secure with one hexagon screw.
- 30 Connect two Lucar connectors as follows:  
Red/light green wire to red wire.  
Black/light green wire to blue wire.
- 31 Pack the wires into the limit switch recesses as shown.
- 32 Position the gasket and cover. Secure with three hexagon screws and two Pozidriv screws.
- 33 Seal the exterior of the unit by applying a rubberised sealing compound such as vehicle body underseal. Special attention must be given to disturbed joints and the wire slot seal.

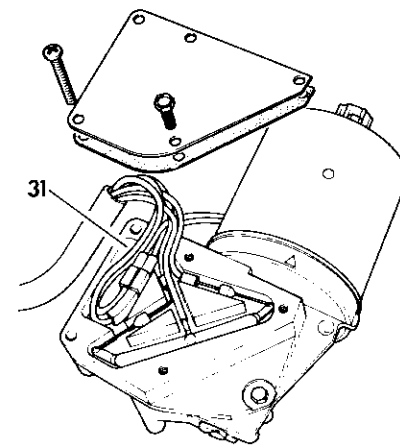
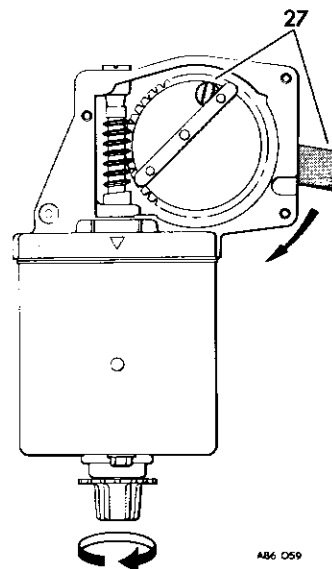

A86 056

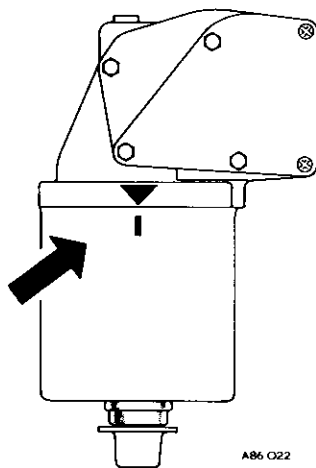

A86 022

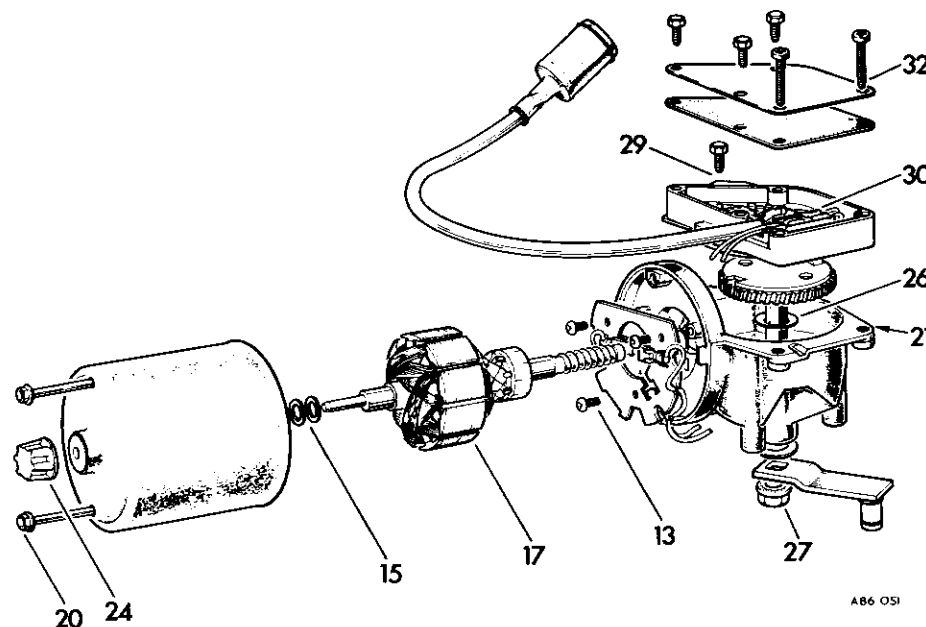

A86 051

## HEADLAMP ASSEMBLY

Overhaul

86.40.15

### Dismantling

- 1 Remove the headlamp assembly, see 86.40.02.
- 2 Remove the nut, lock washer, washer and screw. Remove the harness 'P' clip.
- 3 To assist refitting, scribe the outline of the mounting bracket sides onto the light alloy member.
- 4 Remove four bolts, lock washers and washers. Separate the two assemblies.
- 5 Withdraw the headlamp harness from the light alloy member.
- 6 Safely restrain the spring by rotating the actuator hand knob to position the light alloy member against the metal up stop on the base bracket.
- 7 Remove the circlip and washer.
- 8 Remove the nut, lock washer, washer and special screw.
- 9 Slide the upper end of the link rod from the light alloy member.
- 10 Remove the link rod from the crank arm.
- 11 Remove the bush from the crank arm.
- 12 Remove three screws and lock washers. Manoeuvre the crank arm through the aperture and remove the actuator.
- 13 Ensure that the spring is safely restrained and extended to its weakest working position by checking that the light alloy member is against the metal up stop on the base bracket.
- 14 Retain the spring by strong hand pressure. Carefully remove the nut, lock washer, small washer, large washer and special bolt.
- 15 Remove the nut, lock washer, small washer, large washer and special bolt. Lift away the spring.
- 16 Remove the nut, washer, washer and bolt. Withdraw the light alloy member.
- 17 Withdraw the hinge pin.
- 18 Slacken the locknut. Remove the rubber down stop including the locknut and washer.
- 19 Remove three screws to release the retaining rim and light unit.

- 20 Pull the connector block from the light unit.
- 21 Remove four screws and lock washers. Withdraw the housing and plate.
- 22 If necessary drill out four 'pop rivets' to separate the housing plate.
- 23 To assist refitting, scribe the outline of the mounting bracket onto the box casting.
- 24 Remove four nuts, lock washers and washers. Remove the mounting bracket.
- 25 Remove the grommet from the mounting bracket to release the headlamp harness.

*continued*

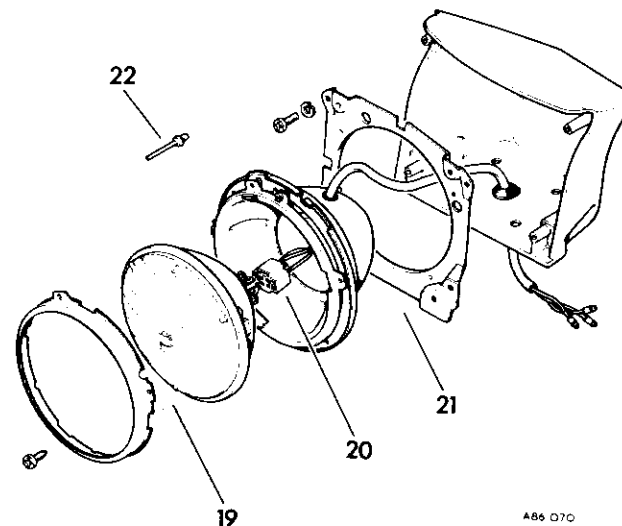
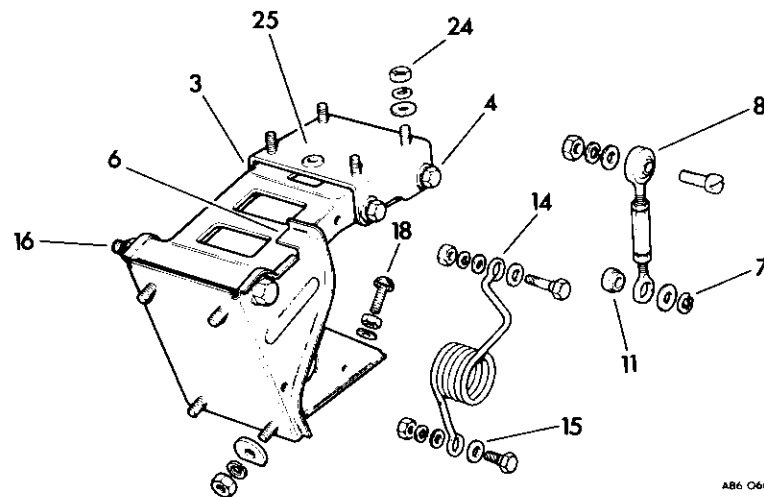

**Reassembling**

- 26 Position the headlamp harness and fit the grommet to the mounting bracket.
- 27 Position the mounting bracket to the scribe lines on the box casting. Secure with four nuts, lock washers and washers.
- 28 If necessary, fit four 'pop rivets' to unite the housing and plate.
- 29 Insert the housing and plate. Secure with four screws and lock washers.
- 30 Push the connector block on to the light unit.
- 31 Position the retaining rim and light unit. Secure with three screws.
- 32 Fit the rubber down stop including the locknut and washer.
- 33 Lubricate the hinge pin working surfaces with P.B.C. (Poly Butyl Cuprysil) grease.
- 34 Insert the hinge pin into the light alloy member.
- 35 Insert the light alloy member into the base bracket. Secure with the bolt, washer, washer and nut.
- 36 Position the spring. Secure with the special bolt, large washer, small washer, lock washer and nut.
- 37 Retain the spring by strong hand pressure. Secure with the special bolt, large washer, small washer, lock washer and nut.
- 38 Manoeuvre the crank arm through the aperture and position the actuator. Ensure that the actuator harness is looped up between the actuator and the base bracket. Secure with three screws and lock washers.
- 39 Lubricate the bush working surfaces with engine oil.
- 40 Fit the bush to the crank arm.
- 41 Position the link rod ends in the turnbuckle so that an equal number of threads are visible at each end.
- 42 Fit the link rod to the bush.
- 43 Slide the upper end of the link rod to the light alloy member.
- 44 Fit the special screw, washer, lock washer and nut.
- 45 Fit the washer and circlip.
- 46 With the headlamp assembly removed from the vehicle perform the primary and secondary adjustment, see 86.40.16.

- 47 Insert the headlamp harness through the light alloy member.
- 48 Position the mounting bracket to the scribe lines on the light alloy member. Secure with four bolts, lock washers and washers.
- 49 Position the harness 'P' clip. Secure with the screw, washer, lock washer and nut.
- 50 Fit the headlamp assembly, see 86.40.02.

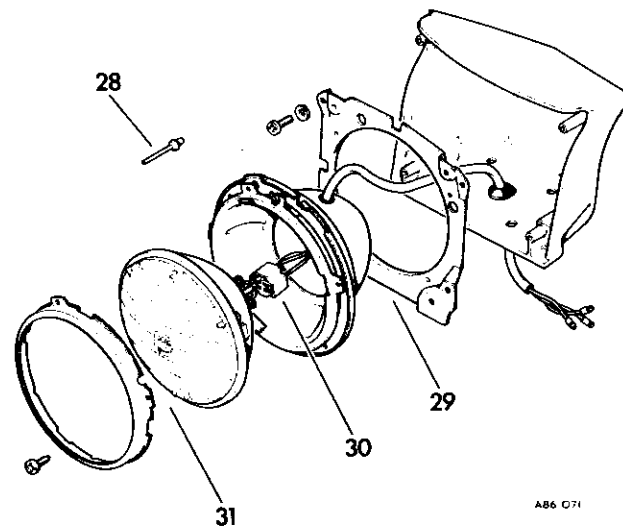

A86 071

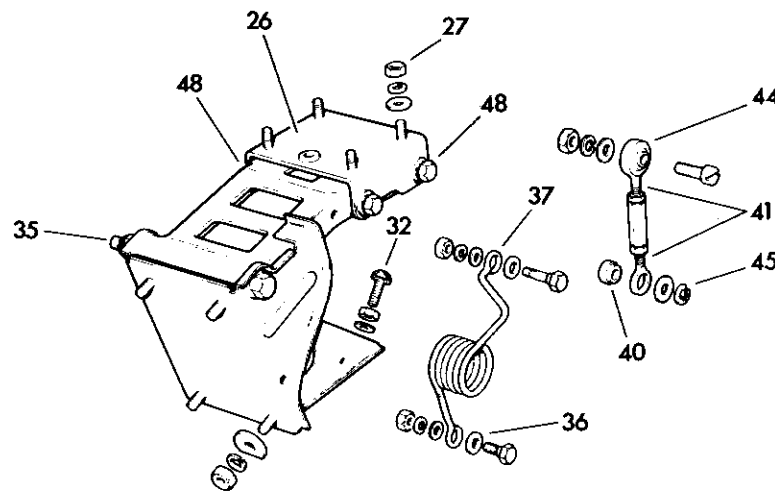

A86 067

## HEADLAMP ASSEMBLY

Adjust

86.40.16

### Primary adjustment

The primary adjustment is to ensure that the light alloy member is forced hard against the metal up stop on the base bracket when the crank arm stops for the up position. This condition is achieved by adjusting the length of the link rod.

This adjustment may be made with the headlamp assembly in situ or removed from the vehicle.

- 1 *Headlamp assembly in situ only:*  
Select the master light switch to raise the headlamps.
- 2 *Headlamp assembly removed from the vehicle only:*  
Using the actuator hand knob rotate the crank arm to obtain the T.D.C. position as shown.
- 3 Slacken two link rod lock nuts. Note that the upper lock nut has a left-hand thread.
- 4 Rotate the turnbuckle by hand – do not use a spanner – until slight resistance is felt as the light alloy member contacts the metal up stop on the base bracket. This is the datum point.
- 5 Rotate a further 4½ flats (270 degrees) using a spanner.  
**NOTE:** This will provide a 'crowd' of 1.20 to 1.40 mm to the length of the link rod. Correct pre-load will then be applied to the up stop.
- 6 Hold the turnbuckle in this position and tighten two lock nuts.

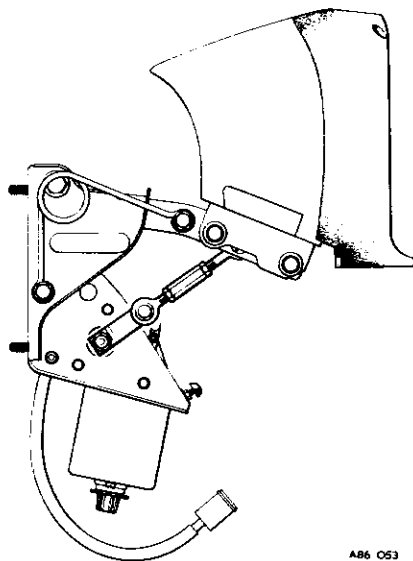

### Secondary adjustment

The secondary adjustment is to ensure that the rubber down stop mounted on the base bracket is suitably compressed by the light alloy member when the crank arm stops for the down position. This condition is achieved by adjusting the position of the rubber down stop.

This adjustment may be made with the headlamp assembly in situ or removed from the vehicle.

- 7 Perform the primary adjustment, see 86.40.16.  
**CAUTION:** The position the light alloy member assumes in the down position is dependent on the length of the link rod. A correct secondary adjustment cannot be achieved until the primary adjustment is correctly set.
- 8 Slacken the rubber down stop lock nut. Screw the rubber down stop to its lowest position.
- 9 *Headlamp assembly in situ only:*  
Select the master light switch to retract the headlamps.
- 10 *Headlamp assembly removed from vehicle only:*  
Using the actuator hand knob rotate the crank arm to obtain B.D.C. position as shown.
- 11 Screw the rubber down stop out by hand until it just contacts the light alloy member. This is the datum point.
- 12 Screw out a further 1¼ turns (480 degrees).  
**NOTE:** This will provide a 'crowd' of 1.00 to 1.20 mm to the downstop.
- 13 Hold the rubber down stop in this position and tighten the lock nut.

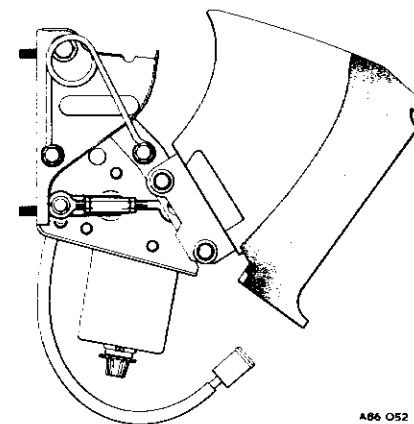

**Box casting adjustment**

The box casting adjustment is to ensure that the top surface of the box casting is correctly aligned with the vehicle body contours when the headlamp is retracted. This condition is achieved by adjusting the position of components.

This adjustment may only be made with the headlamp assembly in situ.

- 14 Perform the primary and secondary adjustment, see 86.40.16.
- CAUTION:** The position the light alloy member assumes in the down position is dependent on the length of the link rod. A correct box casting adjustment cannot be achieved until the primary adjustment is correctly set.
- 15 Ensure that the headlamps are in the retracted position.
- 16 Slacken four nuts securing the base bracket to the vehicle body.
- 17 Move the complete headlamp assembly to align the top surface of the box casting with the vehicle body contours.
- 18 Hold the headlamp assembly in this position and tighten four nuts.
- 19 If sufficient adjustment is not available to achieve alignment perform operations 20 to 22.
- 20 Slacken four bolts securing the mounting bracket to the light alloy member.
- 21 Adjust the relationship of the components to facilitate the operation.
- 22 Hold the components in position and tighten four bolts.
- 23 Repeat operation 15 onwards.

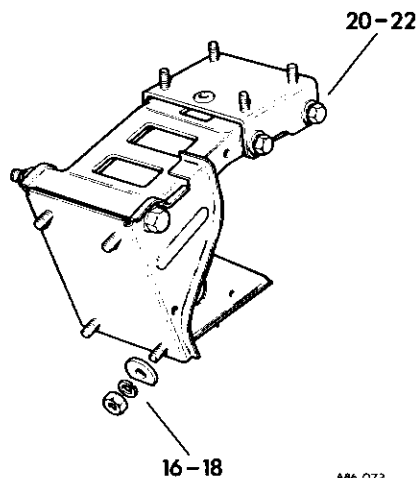

AB6 072

**HEADLAMP****Beam aiming**

86.40.17

Beam aiming can best be accomplished using equipment such as Lucas 'Beamsetter', 'Lev-L-Lite' or 'Beam tester'. This service is available at Triumph distributors or dealers and will ensure maximum road illumination with minimum discomfort to other road users.

With the headlamps in the up position the adjustment is achieved in the same way as for conventional solid mounted Lucas headlamp units. One screw positions the beam in the horizontal plane while a second screw controls beam height.

- 1 Select the master light switch to raise the headlamps.
- 2 Ensure that the headlamp assembly is correctly adjusted, see 86.40.16.
- 3 Gain access to the beam aiming screws by inserting a screwdriver through the 'cut outs' provided in the rubber bezel.
- 4 Screw 'A' positions the beam in the horizontal plane.
- 5 Screw 'B' controls beam height.

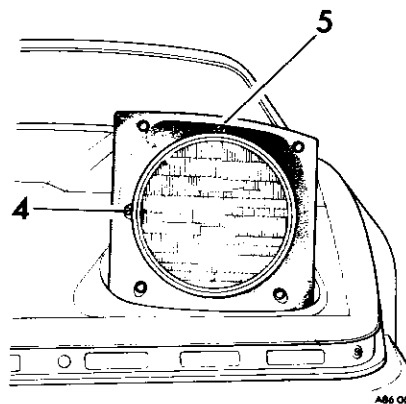

AB6 002

**HEADLAMP CIRCUIT BREAKER****Remove and refit**

86.40.19

**Removing**

- 1 Open the cubby box lid.
- 2 Remove the two Pozidriv screws. Withdraw the lower panel to obtain access to the component mounting plate.
- 3 Locate the circuit breaker attached to the harness using the appropriate illustration.
- 4 Pull off two electrical connectors to detach the circuit breaker from the vehicle.

**Refitting**

- 5 Push on two electrical connectors. The connectors may be fitted either way round.
- 6 Stow the circuit breaker in a suitable position.
- 7 Reverse 1 to 2.

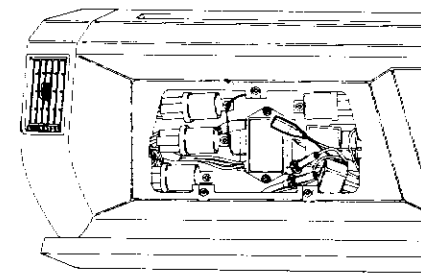



## FRONT PARKING AND FLASHER LAMP

Remove and refit 86.40.26

### Removing

- 1 Remove the lamp harness from the body clip.
- 2 Disconnect three snap connectors.
- 3 Remove two Pozidriv screws and washers. Withdraw the clear lens and the amber plate lens.
- 4 Remove the lens gasket.
- 5 Remove two bulbs from the bayonet fittings.
- 6 Remove two nuts, spring washers and washers.
- 7 Withdraw the lamp base and gasket.

### Refitting

- 8 Insert the lamp base and gasket. Ensure that it is the correct way up with the lens securing tappings horizontal.
- 9 Fit two nuts, spring washers and washers.
- 10 Fit two bulbs to the bayonet fittings.
- 11 Fit the lens gasket.
- 12 Position the amber plate lens to the clear lens. Ensure that the assembly is the correct way up with the screw holes horizontal and the amber plate lens the correct end.
- 13 Insert the lens assembly. Secure with two Pozidriv screws and washers.
- 14 Connect three snap connectors as follows:  
*Left-hand lamp only* –  
Red wire to red wire.  
Green/red wire to green wire.  
Black wire to black wire.  
*Right-hand lamp only* –  
Red wire to red wire.  
Green/white wire to green wire.  
Black wire to black wire.

- 15 Fit the lamp harness to the body clip.

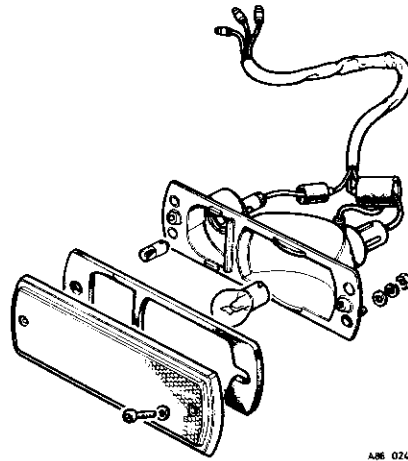

## FRONT FLASHER REPEATER LAMP

Remove and refit 86.40.53

### Removing

- 1 The lamp unit is attached by a groove in the rubber component of the lamp locating in an aperture provided in the vehicle body. Carefully manoeuvre the rubber to allow the complete lamp unit to be withdrawn outwards.
- 2 Pull off the metal bezel.
- 3 Remove the lens.
- 4 Remove the bulb from the bayonet fitting.
- 5 Locate the terminations of the green wire and black wire below the headlamp assembly.
- 6 Release the two wires from the clips and tape.
- 7 Disconnect two snap connectors.
- 8 Provide a length of slave cord about 2 metres long.
- 9 Attach the cord to the two wire ends.
- 10 Attach the other end of the cord to the vehicle body cross-member to prevent it being pulled completely through.
- 11 Carefully withdraw the lamp wires from the vehicle wing cavity.
- 12 Detach the cord from the two wire ends.

### Refitting

- 13 Reverse 1 to 12. Connect two wires as follows:  
*Left-hand only* –  
Green wire to black wire to black wire.  
*Right-hand lamp only* –  
Green wire to green/white wire.  
Black wire to black wire.

## USA Specification Vehicles FRONT MARKER LAMP

Remove and refit 86.40.59

### Removing

- 1 Select the master light switch to raise the headlamps.
- 2 Isolate the battery to extinguish the headlamps.
- 3 Pull the bulb holder from the lamp base.
- 4 Pull the bulb from the bulb holder.
- 5 Disconnect two Lucar connectors.
- 6 Remove two nuts, spring washers and washers.
- 7 Withdraw the lamp assembly. Do not attempt to disassemble the lens from the lamp base.

### Refitting

- 8 Ensure that the rubber gasket is secured to vehicle body.
- 9 Reverse 1 to 7.

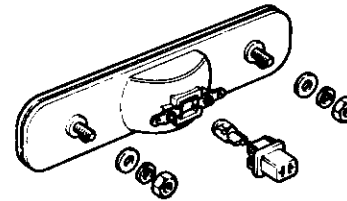

## REAR MARKER LAMP

Remove and refit 86.40.64

### Removing

- 1 Open the luggage boot lid.
- 2 Remove two nuts, spring washers and washers.
- 3 Remove the clamp cover.
- 4 Pull the bulb holder from the lamp base.
- 5 Pull the bulb from the bulb holder.
- 6 Disconnect two Lucar connectors.
- 7 Withdraw the lamp assembly. Do not attempt to disassemble the lens from the lamp base.

### Refitting

- 8 Ensure that the rubber gasket is secured to the vehicle body.
- 9 Reverse 1 to 7.

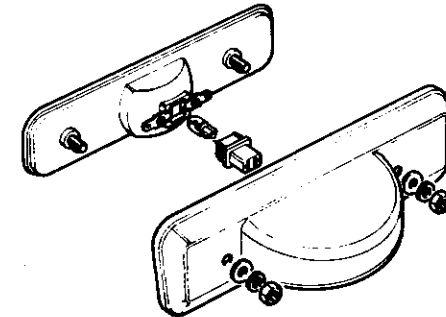

**REAR LAMP ASSEMBLY**

Remove and refit 86.40.70

**Removing**

- 1 Open the luggage boot lid.
- 2 Turn back the floor mat on the appropriate side.
- 3 Remove two trim panel top longer Pozidriv screws.
- 4 Remove two trim panel bottom shorter Pozidriv screws.
- 5 Remove the trim panel.
- 6 Rotate four bulb holders anti-clockwise and remove from the bayonet fittings.
- 7 Remove four bulbs from the bayonet fittings.
- 8 Remove one nut and spring washer. Remove the harness earth tag.
- 9 Remove five nuts, spring washers and washers.
- 10 Withdraw the lens and lens gasket. The lens is a one piece assembly. The lens section may not be replaced individually.
- 11 Withdraw the lamp base and lamp base gasket.

**Refitting**

- 12 Reverse 1 to 11. Fit the four bulb holders so that the wire colour codes are as the left-hand assembly shown. On a right-hand assembly the last wire is GW Green/White.

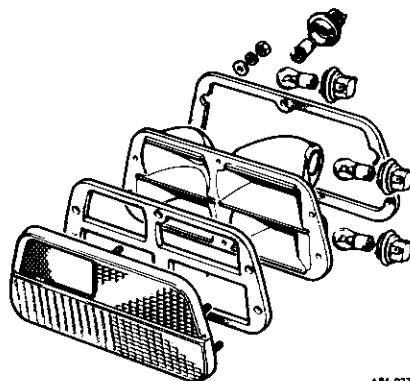

A86 027

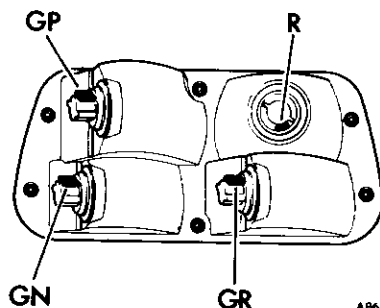

A86 030

GP Green/Purple  
 R Red  
 GN Green/Brown  
 GR Green/Red

**PLATE ILLUMINATION LAMP**

Remove and refit 86.40.86

**Removing**

- 1 Open the luggage boot lid to obtain improved access.
- 2 Remove two Pozidriv screws.
- 3 Manoeuvre the lamp from the body panel aperture. Take care not to break the festoon bulb.
- 4 Carefully remove the festoon bulb.
- 5 Remove two Lucar connectors.

**Refitting**

- 6 Reverse 1 to 5. The two Lucar connectors may be fitted either way round.

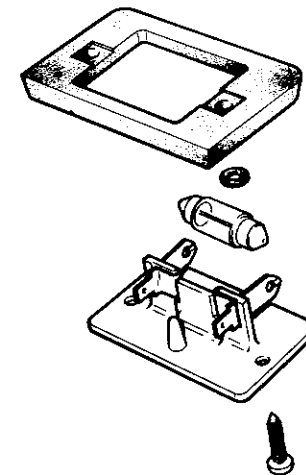

A86 028

**MAP/COURTESY LAMP**

Remove and refit 86.45.10

**Removing**

- 1 Isolate the battery.
- 2 Carefully prise the rearward edge of the lamp outwards to free it from the door trim pad.
- 3 Carefully remove the festoon bulb.
- 4 Note the wire colour codes and positions.
- 5 Remove the three Lucar connectors.

**Refitting**

- 6 Reverse 1 to 5.

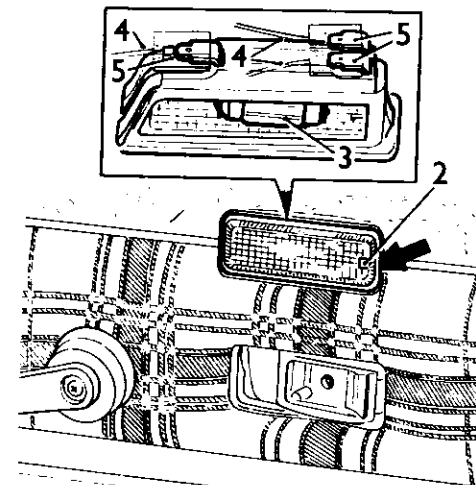

A86230

## INSTRUMENT ILLUMINATION

### Remove and refit 86.45.32

The four instrument illumination assemblies may be considered as a composite part of the instrument panel. Each instrument illumination assembly consists of three parts. The bulb and bulb holder which may best be removed from the concealed side of the instrument panel. The green dome cover which will not normally require to be removed.

#### Removing

All operations:

- 1 Isolate the battery.
- 2 Remove the fascia centre grille, see 76.55.14.
- 3 Remove the fascia instrument cowl, see 76.46.17.
- 4 Read the remainder of this operation and decide the best approach for the specific operation that is to be performed.

Any bulb and bulb holder may be removed as follows:

- 5 At the concealed side of the instrument panel proceed as follows: Rotate the appropriate bulb holder anti-clockwise and carefully withdraw from the bayonet fitting.
- 6 If satisfactory access is not available at the concealed side of the instrument panel proceed as follows: Perform 88.20.01 operations 3 to 9. Withdraw the instrument panel as shown. Rotate the appropriate bulb holder anti-clockwise and carefully withdraw from the bayonet fitting.
- 7 Pull the bulb from the bulb holder.  
Any green dome cover may be removed as follows:
- 8 Remove three Pozidriv screws and washers.
- 9 Carefully slide the lens upwards following the path of its natural arc.
- 10 Lift out the face panel.
- 11 Remove the speedometer, see 88.30.01 or the tachometer, see 88.30.21 to obtain access to the appropriate green dome cover.
- 12 Remove the green dome cover from the housing claws. Take care not to break a claw.

#### Refitting

- 13 Reverse all operations performed.

## HEATER CONTROL ILLUMINATION

### Remove and refit 86.45.44

#### Removing

- 1 Remove two Pozidriv screws.
- 2 Lower the panel downwards.
- 3 Any of the four bulb holders may now be removed by tilting the panel and sliding out a bulb holder.
- 4 Remove the bulb from the bayonet fitting.

#### Refitting

- 5 Reverse 1 to 4.

## FASCIA SWITCH PANEL ILLUMINATION

### Remove and refit 86.45.47

#### Removing

- 1 Isolate the battery.
- 2 Remove two Pozidriv screws and washers.
- 3 Withdraw the panel.
- 4 Either of the two bulb holders may now be removed by carefully pulling from the housing.
- 5 Pull the bulb from the bulb holder.

#### Refitting

- 6 Reverse 1 to 5.

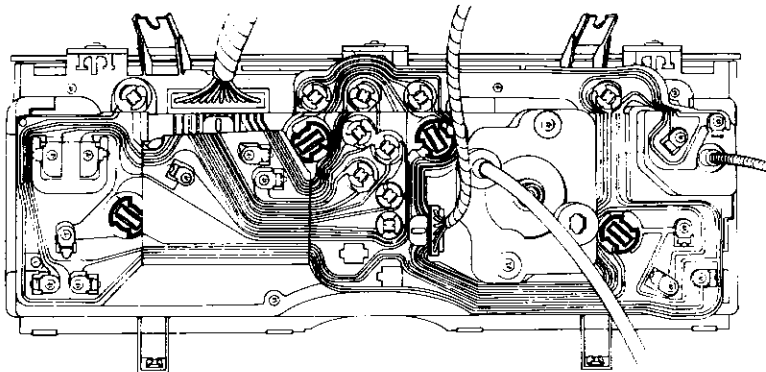

AB6 073

**WARNING LIGHT****Remove and refit 86.45.60**

The warning light assemblies may be considered as a composite part of the instrument panel. Each warning light assembly consists of three parts. The bulb holder which may only be removed from the concealed side of the instrument panel. The bulb which may be removed from either side of the instrument panel. The annotated lens which may only be removed from the exposed side of the instrument panel.

**Removing**

All operations:

- 1 Isolate the battery.
- 2 Remove the fascia centre grille, see 76:55.14.
- 3 Remove the fascia instrument cowl, see 76.46.17.
- 4 Read the remainder of this operation and decide the best approach for the specific operation that is to be performed.

Any bulb holder may be removed as follows:

- 5 At the concealed side of the instrument panel proceed as follows: Rotate the appropriate bulb holder anti-clockwise and carefully withdraw from the bayonet fitting.
- 6 If satisfactory access is not available at the concealed side of the instrument panel proceed as follows: Perform 88.20.01 operations 3 to 9. Withdraw the instrument panel as shown. Rotate the appropriate bulb holder anti-clockwise and carefully withdraw from the bayonet fitting.
- 7 Pull the bulb from the bulb holder. Any bulb or annotated lens may be removed as follows:
- 8 Remove three Pozidriv screws and washers.
- 9 Carefully slide the lens upwards following the path of its natural arc.
- 10 Lift out the face panel.
- 11 Lift out the appropriate annotated lens.
- 12 Pull the bulb from the bulb holder.

**Refitting**

- 13 Reverse all operations performed.

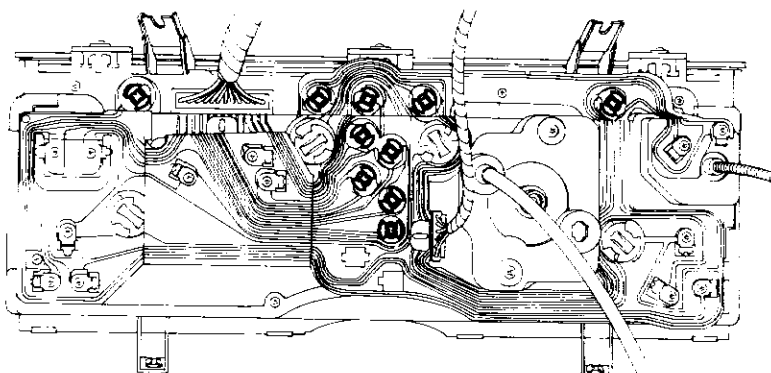

A86 O64

**HAZARD WARNING LIGHT****Remove and refit 86.45.76****Removing**

- 1 Isolate the battery.
- 2 Remove two Pozidriv screws and washers.
- 3 Withdraw the panel.
- 4 Disconnect the hazard switch harness plug.
- 5 Pull the bulb from the harness plug.

**Refitting**

- 6 Reverse 1 to 5.

**RADIO –  
USA Specification Vehicles****Door speaker –  
remove and refit 86.50.13****Removing**

- 1 Remove the door trim pad. 76.34.01.
- 2 Remove the four Pozidriv screws and spring clips securing the speaker to the trim pad.
- 3 Withdraw the speaker.

**Refitting**

- 4 Reverse instructions 1 to 3.

**RELAYS – U.K. AND EUROPE  
STARTER MOTOR RELAY****Remove and refit 86.55.05****Removing**

- 1 Open the cubby box lid.
- 2 Remove two Pozidriv screws. Withdraw the lower panel to obtain access to the component mounting plate.
- 3 Locate the starter motor relay using the appropriate illustration.
- 4 Remove the Pozidriv screw.
- 5 Pull the relay from the harness plug.

**Refitting**

- 6 Reverse 1 to 5.

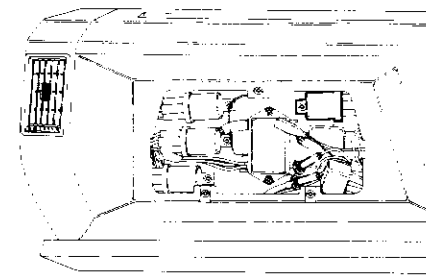

## HORN RELAY

Remove and refit

86.55.09

### Removing

- 1 Open the cubby box lid.
- 2 Remove two Pozidriv screws. Withdraw the lower panel to obtain access to the component mounting plate.
- 3 Locate the horn relay using the appropriate illustration.
- 4 Remove the Pozidriv screw.
- 5 Pull the relay from the harness plug.

### Refitting

- 6 Reverse 1 to 5.

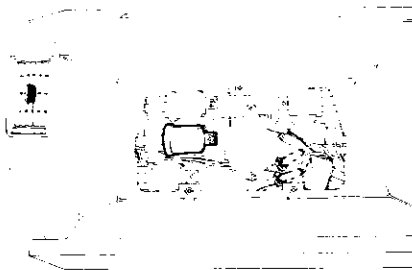

## HAZARD FLASHER UNIT

Remove and refit

86.55.12

### Removing

- 1 Locate the flasher unit mounted in a clip attached to the component mounting plate by placing the head near the floor under the glovebox and looking upwards.  
**NOTE:** The illustration shows the flasher unit position looking through the glovebox.
- 2 Pull the clip from the component mounting plate.
- 3 Disconnect two Lucar connectors.
- 4 Remove the flasher unit from the clip.

### Refitting

- 5 Reverse 1 to 4. Connect two Lucar connectors as follows:  
Purple wire to terminal B.  
Light green/pink wire to terminal L.

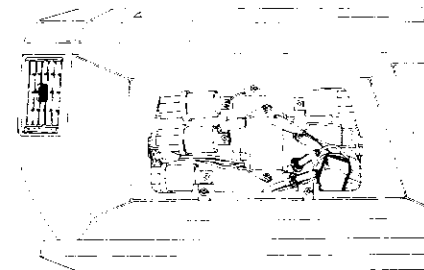

## TURN SIGNAL FLASHER UNIT

Remove and refit

86.55.11

### Removing

- 1 Locate the flasher unit mounted in a clip attached to the fascia support rail forward of the choke and bonnet release controls.
- 2 Pull the flasher unit from the clip.
- 3 Disconnect two Lucar connectors.

### Refitting

- 4 Reverse 1 to 3. Connect two Lucar connectors as follows:  
Light green/slate wire to terminal B.  
Light green/brown wire to terminal L.

## HEADLAMP – RUN/STOP RELAY

Remove and refit

86.55.20

### Removing

- 1 Open the cubby box lid.
- 2 Remove two Pozidriv screws. Withdraw the lower panel to obtain access to the component mounting plate.
- 3 Locate the left-hand headlamp run/stop relay or the right-hand headlamp run/stop relay using the appropriate illustration.
- 4 Remove the Pozidriv screw.
- 5 Pull the relay from the harness plug.

### Refitting

- 6 Reverse 1 to 5.

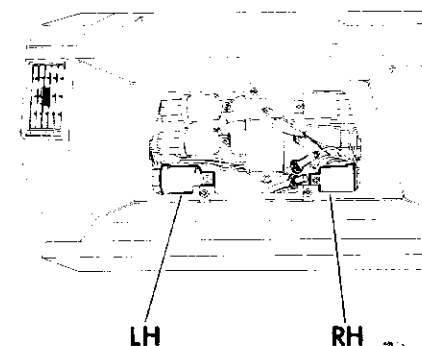

LH Left-hand run/stop relay.  
RH Right-hand run/stop relay.

## AIR CONDITIONING – DELAY CIRCUIT RELAY

Remove and refit 86.55.30

### Removing

- 1 Open the bonnet.
- 2 Locate the relay attached to a forward engine bay panel.
- 3 Remove the Pozidriv screw.
- 4 Disconnect the harness plug.

### Refitting

- 5 Reverse 1 to 4. Ensure that the harness earth tag is included in the screw assembly.

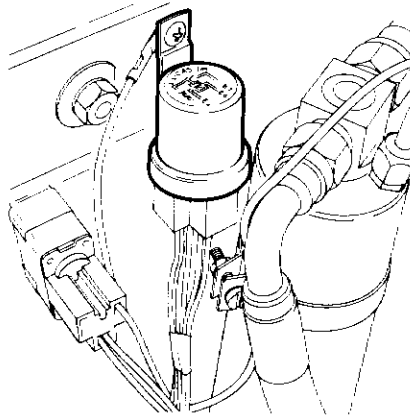

AB6 087

## FLASHER UNIT

Air conditioning – delay circuit  
flasher unit – remove and refit 86.55.31

### Removing

- 1 Open the bonnet.
- 2 Locate the flasher unit mounted in a clip attached to a forward engine bay panel.
- 3 Pull the flasher unit from the clip.
- 4 Disconnect the harness plug.

### Refitting

- 5 Connect the harness plug. Ensure that the flasher unit Lucar blades are fitted into the harness plug operational sockets.
- 6 Reverse 1 to 3.

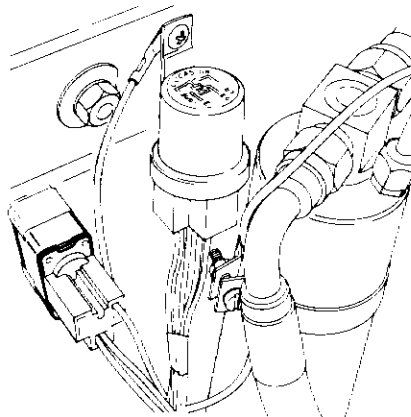

AB6 088

## HEADLAMP – FLASH RELAY

Remove and refit 86.55.37

### Removing

- 1 Open the cubby box lid.
- 2 Remove two Pozidriv screws. Withdraw the lower panel to obtain access to the component mounting plate.
- 3 Locate the headlamp flash relay using the appropriate illustration.
- 4 Remove the Pozidriv screw.
- 5 Pull the relay from the harness plug.

### Refitting

- 6 Reverse 1 to 5.

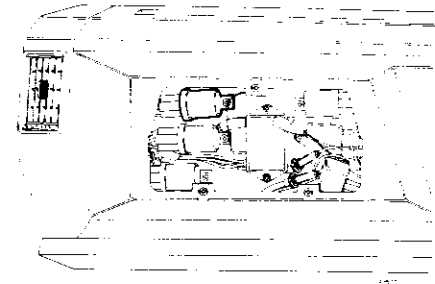

## CONTROL UNIT

Headlamp – flash control unit –  
remove and refit 86.55.38

### Removing

- 1 Open the cubby box lid.
- 2 Remove two Pozidriv screws. Withdraw the lower panel to obtain access to the component mounting plate.
- 3 Locate the headlamp flash control unit using the appropriate illustration.
- 4 Remove the Pozidriv screw.
- 5 Depress the claw lever and pull the control unit from the harness multi-contact plug.

### Refitting

- 6 Reverse 1 to 5.

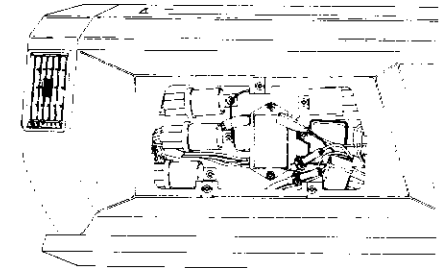

## RELAYS – USA Specification Vehicles

Data  
 Manufacturer . . . . . Lucas  
 Type . . . . . 26RA

### RELAY CHART

Illustration reference number	Wiring diagram reference number	Relay	Lucas part no.	Triumph part no.	Relay colour	Winding terminals	Normally open single contact	Normally open dual contact	Change over contacts	
									Common contact	Switched contacts
1	9	Starter motor relay	33365	UKC 7219	Blue	85 and 86		30/51 87 and 87A		
2	63	Air conditioning—control relay	33365	UKC 7219	Blue	85 and 86		30/51 87 and 87A		
3	19	Headlamp—R.H. run/stop relay	33362	UKC 2416	Black	85 and 86			30/51	87 and 87A
4	19	Headlamp—L.H. run/stop relay	33362	UKC 2416	Black	85 and 86			30/51	87 and 87A
5*	47	Horn relay (some vehicles)	33362	UKC 2416	Black	85 and 86	30/51 and 87			
Mounted in engine bay see 86.55.30	73	Air conditioning—delay circuit relay	33362	UKC 2416	Black	85 and 86	30/51 and 87			

\*Fitted in this position on some vehicles – usually found in the engine bay adjacent to the wiper motor.

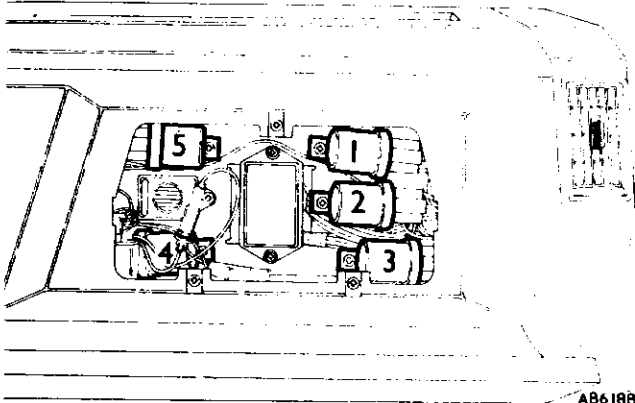

## RELAY

Air conditioning – control relay –  
remove and refit 86.55.10

### Removing

- 1 Open the cubby box lid.
- 2 Withdraw the lower panel to obtain access to the component mounting plate.
- 3 Locate the air conditioning – control relay using the appropriate illustration.
- 4 Remove the Pozidriv screw.
- 5 Pull the relay from the harness plug.

### Refitting

- 6 Reverse 1 to 5.

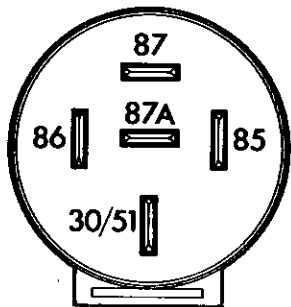
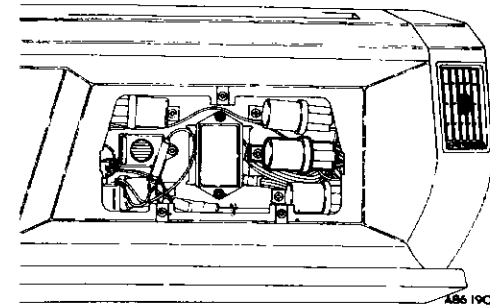

AB6 089



## RELAY

Headlamp — run/stop relay —  
remove and refit 86.55.20

### Removing

- 1 Open the cubby box lid.
- 2 Withdraw the lower panel to obtain access to the component mounting plate.
- 3 Locate the left-hand headlamp run/stop relay or the right-hand headlamp run/stop relay using the appropriate illustration.
- 4 Remove the Pozidriv screw.
- 5 Pull the relay from the harness plug.

### Refitting

- 6 Reverse 1 to 5.

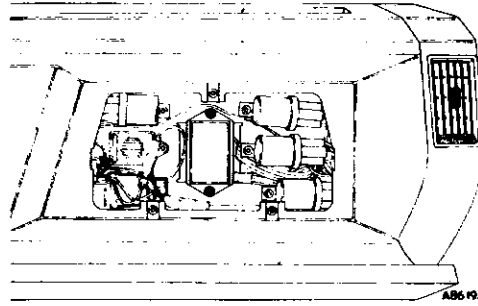

*Left-hand headlamp run/stop relay*

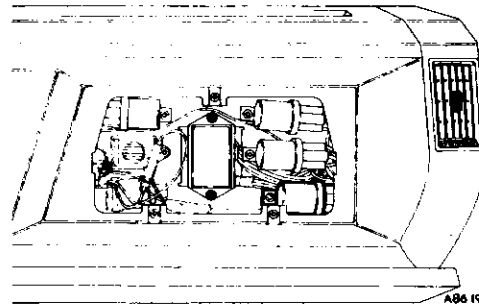

*Right-hand headlamp run/stop relay*

## SEAT BELT — TIMER/BUZZER MODULE

Remove and refit 86.57.08

### Removing

- 1 Open the cubby box lid.
- 2 Withdraw the lower panel to obtain access to the component mounting plate.
- 3 Locate the timer/buzzer module.
- 4 Remove the Pozidriv screw.
- 5 Withdraw the module from the harness multi-contact plug.

### Refit

- 6 Reverse 1 to 5.

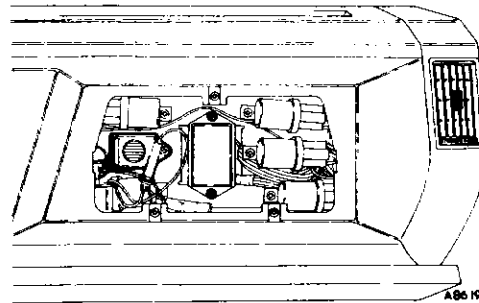

**STARTER MOTOR**

86.60.00

<b>Data</b>	
Manufacturer .....	Lucas
Type .....	2M100 PE
Lucas part number .....	25703
Triumph part number .....	TKC 0020
<b>Motor</b>	
Yoke diameter .....	4 in (101.60 mm)
Light running – speed .....	6,000 rev/min
current .....	40 amp.
torque .....	Not stated
Load running – speed .....	1,000 rev/min
current .....	300 amp.
torque .....	7.3 lbf ft (1.01 kgf m)
Locked – speed .....	Nil
current .....	463 amp.
torque .....	14.4 lbf ft (1.99 kgf m)
Commutator minimum skimming thickness .....	0.140 in (3.56 mm)
Brush length – new .....	0.710 in (18.03 mm)
renew if less than .....	0.375 in (9.53 mm)
Brush spring tension .....	36 ozf (1000 gf)
Shaft end-float: maximum between bush and Spire retaining ring .....	0.010 in (0.25 mm)
Bearing renewal mandrel diameter:	
Commutator end cover bearing .....	0.4377 in (11.118 mm)
Drive end bracket bearing .....	0.4729 in (12.012 mm)
<b>Solenoid</b>	
Pull-in winding resistance – measured between unmarked ‘WR wire’ connector and ‘STA’ terminal .....	0.25 to 0.27 ohm
Hold-in winding resistance – measured between unmarked ‘WR wire’ connector and unit body .....	0.76 to 0.80 ohm

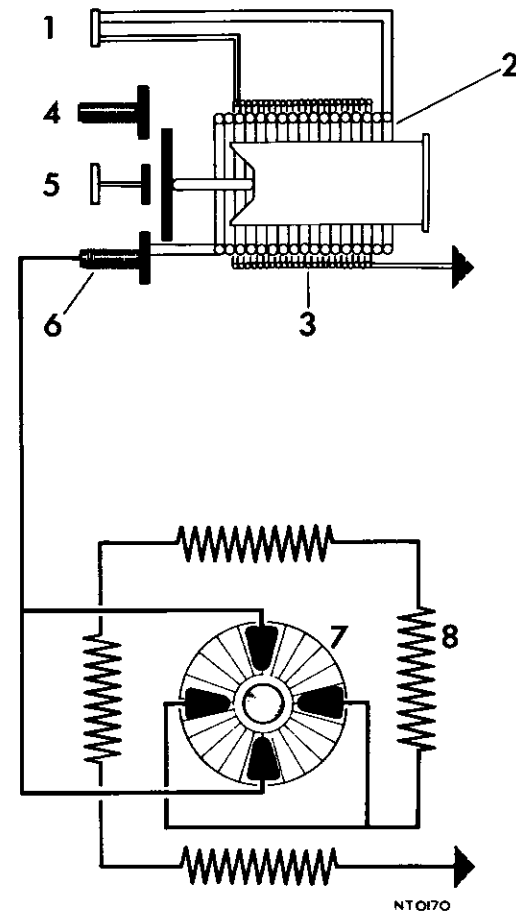

1. Unmarked ‘WR wire’ connector
2. Pull-in winding
3. Hold-in winding
4. Solenoid battery terminal
5. IGN connector for ballast ignition
6. Solenoid motor terminal
7. Brushes and commutator
8. Field windings

## STARTER MOTOR

### Remove and refit

86.60.01

#### Removing

- 1 Drive the vehicle onto a ramp.
- 2 Isolate the battery.
- 3 Raise the ramp.
- 4 Lower the complete exhaust system. It is not necessary to remove it from the vehicle.
  - a Remove two bolts, spring washers and washers at the gearbox bracket.
  - b Remove two nuts, spring washers, washers and bolts at the bell-housing bracket.
  - c Unhook two rubber rings at the front silencer hanger.
  - d Unhook two rubber rings at the tail pipe hanger.
  - e Remove three nuts, spring washers and washers at the manifold flange.
- 5 Unclip the heat shield from the starter solenoid.
- 6 Swing the front of the exhaust pipe under the engine and temporarily secure under the right-hand side of the vehicle.
- 7 Disconnect the Lucar connector.
- 8 Remove the nut and spring washer. Disconnect the battery lead from the solenoid.
- 9 Slacken one bolt indicated at the bell-housing exhaust bracket.
- 10 Remove the lower mounting bolt, spring washer and nut.
- 11 Remove the middle mounting bolt, cable clip, spring washer and nut.
- 12 Remove the upper mounting bolt, spring washer and nut.  
**NOTE:** This bolt may be removed with the starter motor tilted.
- 13 Manoeuvre the starter motor downwards from the vehicle.

#### Refitting

- 14 Position the starter motor upwards to the vehicle.
- 15 Fit the upper mounting bolt, spring washer and nut finger-tight.  
**NOTE:** This bolt may be inserted with the starter motor tilted.

- 16 Fit the middle mounting bolt, cable clip, spring washer and nut finger-tight.
- 17 Fit the lower mounting bolt, spring washer and nut finger-tight. Include the exhaust bell-housing bracket in the assembly.
- 18 Tighten the upper bolt assembly.
- 19 Tighten the middle bolt assembly.
- 20 Tighten the lower bolt assembly.
- 21 Tighten one bolt indicated at the bell-housing exhaust bracket.
- 22 Connect the battery lead to the solenoid. Fit the spring washer and nut.
- 23 Connect the Lucar connector.
- 24 Swing the front of the exhaust pipe under the engine and position to the manifold.
- 25 Clip the heat shield to the starter solenoid.
- 26 Reverse operation 4. Fit a new exhaust manifold gasket.
- 27 Lower the ramp.
- 28 Ensure that the electrical leads are stowed along the inside edge of the heat shield.
- 29 Connect the battery.

## STARTER MOTOR

### Roller clutch drive – remove and refit

86.60.07

#### Removing

- 1 Dismantle the starter motor, see 86.60.13.
- 2 Provide a special punch as shown.
- 3 Position the special punch over the shaft end and tap the thrust collar from the jump ring towards the roller clutch drive.
- 4 Prise the jump ring from the shaft groove.
- 5 Remove the thrust collar.
- 6 Remove the roller clutch drive.

#### Refitting

- 7 Lubricate the splines and pinion bearing with grease. Shell SB 2628 for home market and cool climates. Shell Retinax A for hot climates.
- 8 Fit the roller clutch drive with the engaging lever convex surface facing the solenoid.
- 9 Fit the thrust collar with the open side facing the shaft end as shown.
- 10 Prise the jump ring into the shaft groove.
- 11 Force the thrust collar over the jump ring.

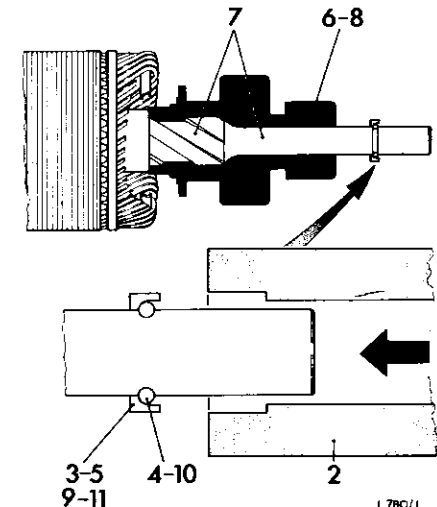
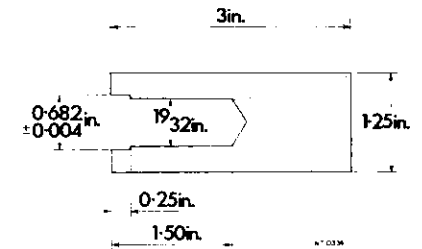

L780/1

**STARTER MOTOR**

Overhaul

86.60.13

**Dismantling**

**NOTE:** Dismantling of the starter motor will necessitate the destruction of one Spire retaining ring. Ensure that a new Spire retaining ring for the armature shaft is available before proceeding further. This item is included in the sundry parts kit, Lucas part no. 54246438 or Triumph part no. 520466.

- 1 Remove the nut, spring washer and washer to free the connector link from the solenoid.
- 2 Carefully prise off the metal end cap.

- 3 Use a small chisel to cut a number of claws and remove the Spire retaining ring. Do not prise off the Spire retaining ring without cutting a number of claws as such action may damage the bearing end face, armature shaft and bearing surface when the shaft is withdrawn.
- 4 Remove two through bolts and spring washers.
- 5 Withdraw the yoke and commutator end cover assembly.
- 6 Remove the thrust washer.
- 7 Remove the rubber seal block.
- 8 Employ a second operator to support the yoke by hand. Use a length of wood of approximately 0.75 in (20

mm) diameter to tap the commutator end cover from the yoke.

- 9 Lift out two field winding brushes from the brush box to separate the commutator end cover from the yoke.
- 10 Tap out the pivot pin. The staking will fold inwards during withdrawal.
- 11 Remove two bolts and spring washers. Withdraw the solenoid leaving the plunger attached to the engaging lever.
- 12 Remove the return spring.
- 13 Withdraw the armature, roller clutch drive and plunger assembly from the drive end bracket.
- 14 Unhook the plunger complete with the solenoid seal moulding from the engaging lever.

**Bearings**

- 15 Inspect the porous bronze bearing bushes for wear.
- 16 If necessary renew either bush as follows:  
Extract the bush using a suitable press and mandrel. Prepare the porous bronze bush by immersing it in thin engine oil for 24 hours or thin engine oil heated to 100° C for two hours. Allow the bush to cool in the oil. Fit the bush using a suitable press and a highly polished, shouldered mandrel of the appropriate dimension given in Data. Do not ream the bush after fitting or its porosity may be impaired.

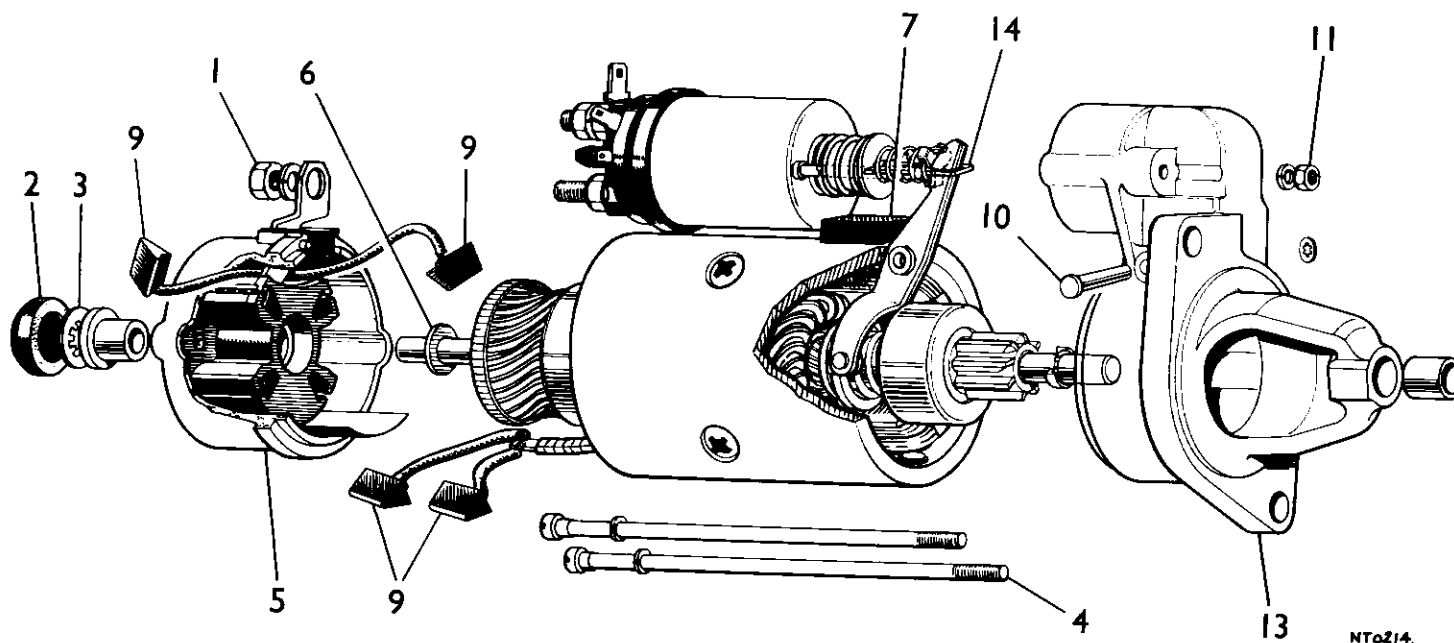

NTa214.

**Brushes**

- 17 Clean the brushes and brush box with a petrol-moistened cloth.
- 18 Check that the brushes move freely in the brush box.
- 19 Check the brush spring pressure as shown. Position a new brush so that the top protrudes 0.060 in (1.50 mm) above the brush box. Brush spring pressure should be as given in Data. Repeat for the remaining three springs. If the pressure is low renew the commutator end bracket assembly.
- 20 Check the brush length. Renew the brushes if less than the length given in Data.
- 21 If necessary renew the commutator end cover brushes. Brushes are supplied attached to a new connector link. Withdraw two brushes from the brush box. Withdraw the connector link. Position new brushes as shown. Retain the longer flexible under the flap.
- 22 If necessary renew the field winding brushes. Brushes are supplied attached to a common flexible. Cut the old flexibles 0.250 in (6 mm) from the joint. Solder the new flexible to the ends of the old flexible. Do not attempt to solder direct to the field winding strip as the strip may be produced from aluminium.

### Commutator

- 23 Clean the commutator with a petrol-moistened cloth. If the commutator is in good condition it will be smooth and free from pits or burned spots.
- 24 If necessary polish the commutator with fine glass-paper.
- 25 If necessary skim the commutator. Separate the armature from the roller clutch drive by performing 86.60.07. Mount the armature in a lathe and rotate at high speed. Using a very sharp tool, take a light cut. Polish with fine glass-paper. Do not cut below the minimum skimming thickness given in Data. Do not undercut insulators between segments.

### Roller clutch drive

- 26 Do not wash the roller clutch in petrol as such action would remove lubricant from the sealed unit. It may be cleaned by wiping with a petrol-moistened cloth.
- 27 Check that the clutch locks in one direction and rotates smoothly in the other. The unit should move freely round and along the armature shaft splines.
- 28 The roller clutch is a sealed unit. If the above conditions are not met repair by replacement of the roller clutch unit.

### Solenoid

- 29 Assembly of the starter solenoid involves soldering and sealing complications. It is therefore not advisable to attempt to service this unit. If the solenoid operation is suspect, repair by replacement of the solenoid unit.
- 30 The plunger is matched with the solenoid body. The spares unit of purchase is a matched solenoid and plunger and the box also contains a return spring. All three items should be fitted as a set.

### Assemble

- 31 Ensure that the bearing surfaces on the armature shaft are burr-free.
- 32 Hook the plunger complete with the solenoid seal moulding onto the engaging lever.
- 33 Insert the armature, roller clutch drive and plunger assembly into the drive end bracket.
- 34 Fit the return spring to the solenoid.
- 35 Fit the solenoid so the 'STA' terminal is adjacent to the yoke. Secure with two bolts and spring washers. Ensure that the plunger does not unhook during this operation.
- 36 Lightly grease the pivot pin. Align the holes and insert the pivot pin. Secure by staking. Ensure that the plunger does not unhook during this operation.
- 37 Insert two field winding brushes into the brush box with flexibles positioned as shown.
- 38 Position the commutator end cover to the yoke.
- 39 Position the rubber seal block.
- 40 Fit the thrust washer.
- 41 Holding the commutator end cover firmly to the yoke, insert the assembly.
- 42 Fit two through bolts and spring washers.
- 43 If necessary adjust the position of the rubber seal block.
- 44 Fit a new Spire retaining ring to the armature shaft.
- 45 Fit the metal end cap.
- 46 Fit washer, spring washer and nut to secure the connector link to the solenoid.

### IGNITION/STARTER SWITCH

Remove and refit 86.65.02

#### Removing

- 1 Isolate the battery.
- 2 Unscrew two long Pozidriv screws and remove the nacelle upper and lower halves.  
**NOTE:** The screws have a long threaded length of approximately 20 mm. A long 'unscrew time' should be expected.
- 3 Note the switch harness wire run.
- 4 Disconnect one harness plug.
- 5 Remove two small Pozidriv screws.
- 6 Remove the switch complete with its harness from the vehicle.

#### Refitting

- 7 Position the switch harness wire run as noted at operation 3 above. Insert the switch into the steering column lock assembly. Note the keyway and ensure that the lock shaft and switch shaft align correctly.
- 8 Fit two small Pozidriv screws.
- 9 Connect one harness plug.
- 10 Position the nacelle upper and lower halves. Secure with two long Pozidriv screws.
- 11 Connect the battery.

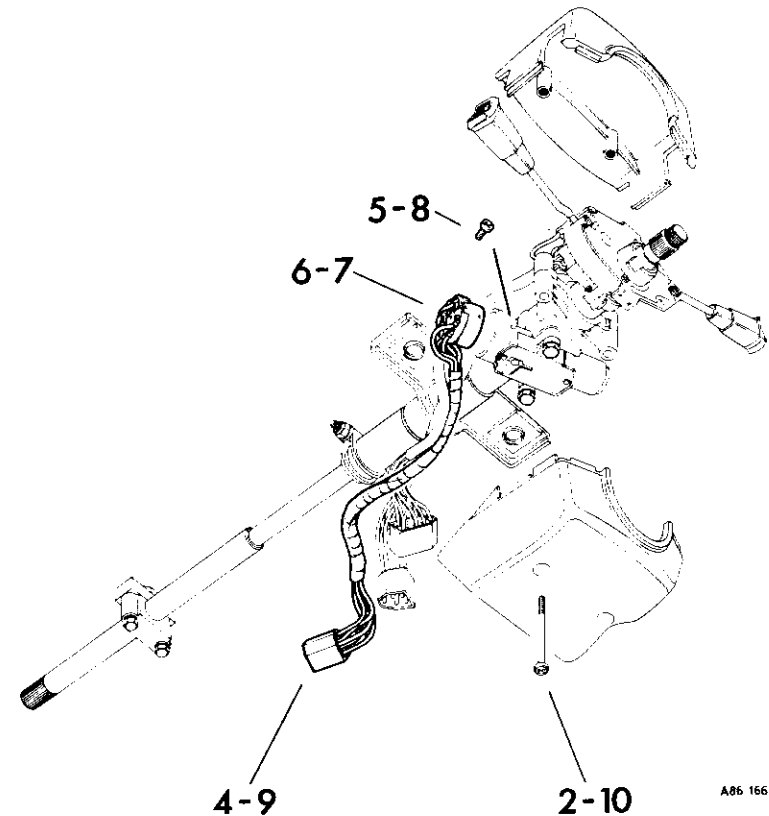

**MASTER LIGHT SWITCH**

– Remove and refit **86.65.09**

**Removing**

- 1 Remove the fascia switch panel, see 86.65.66.
- 2 Using a small screwdriver carefully prise off two Spire clips.
- 3 Remove the face panel and the switch identification strip assembly.
- 4 Push inwards one plastic clip on the switch and withdraw the switch from the panel.

**Refitting**

- 5 Reverse 1 to 4. Insert the switch so that the 'symbol' is at the lower edge.

**PANEL RHEOSTAT**

Remove and refit **86.65.12**

**Removing**

- 1 Isolate the battery.
- 2 Pull out the centre console tray.
- 3 Locate the hole in the knob. Insert a suitable probe into the hole and while depressing pull the knob from the shaft.
- 4 Unscrew the bezel.
- 5 Withdraw the panel rheostat downwards from the centre console panel.
- 6 Remove the spring washer.
- 7 Note the wire colour codes and positions.
- 8 Disconnect two Lucar connectors.

**Refitting**

- 9 Reverse 1 to 8.

**DOOR SWITCH**

Remove and refit **86.65.14**

**Removing**

- 1 Open the appropriate door.
- 2 Remove the single screw.
- 3 Withdraw the switch.
- 4 Disconnect one Lucar connector.

**Refitting**

- 5 Reverse 1 to 4.

**FRONT FOG LAMP SWITCH**

Remove and refit **86.65.19**

*When fitted***Removing**

- 1 Remove the fascia switch panel, see 86.65.66.
- 2 Using a small screwdriver carefully prise off two Spire clips.
- 3 Remove the face panel and the switch identification strip assembly.
- 4 Push inwards one plastic clip on the switch and withdraw the switch from the panel.

**Refitting**

- 5 Reverse 1 to 4. Insert the switch so that the 'symbol' is at the lower edge.

**REVERSE LAMP SWITCH**

Remove and refit **86.65.20**

*Four speed gearbox only***Removing**

- 1 Drive the vehicle onto a ramp.
- 2 Raise the ramp.
- 3 Disconnect two snap connectors.
- 4 Unscrew the switch from the gearbox extension.
- 5 Collect up the distance washer.

**Refitting**

- 6 Fit the distance washer to the switch.
- 7 Screw the switch into the gearbox extension and tighten lightly.  
**NOTE:** No further adjustment is required.
- 8 Connect two snap connectors. The connectors may be fitted either way round.
- 9 Perform a function test as follows: Switch on ignition. Select reverse. The reverse lamps should now be illuminated. Select any other gear. The reverse lamps should now be off.

*Five speed gearbox only***Removing**

- 10 Drive the vehicle onto a ramp.
- 11 Unscrew the gear lever knob.
- 12 Lift off the gear lever gaiter.
- 13 Remove four Pozidriv screws and washers. Lift out the draught excluder and plate.
- 14 Raise the ramp.
- 15 Disconnect two snap connectors.
- 16 Lower the ramp.
- 17 Slacken the locknut.
- 18 Unscrew the switch from the gearbox extension.

**Refitting**

- 19 Ensure that the locknut is fitted to the switch.
- 20 Screw the switch into the gearbox extension.
- 21 Adjust the switch position as follows: Provide a test lamp circuit as shown. Select reverse gear. Screw the switch inwards until the lamp just illuminates. This is the datum position. Screw the switch inwards a further 3 flats (180 degrees). Hold the switch in this position and tighten the locknut.
- 22 Raise the ramp.
- 23 Connect two snap connectors. The connectors may be fitted either way round.
- 24 Lower the ramp.
- 25 Perform a function test as follows: Switch on ignition. Select reverse. The reverse lamps should now be illuminated. Select any other gear. The reverse lamps should now be off.
- 26 Reverse 11 to 13.

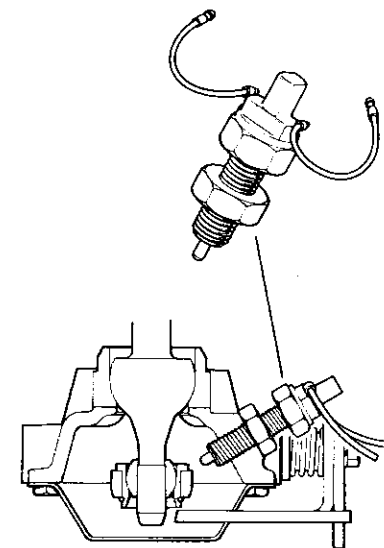

## PASSENGER'S SEAT SWITCH

Remove and refit 86.65.29

### Removing

- 1 Remove the passenger's seat, see 76.70.05.
- 2 Unhook two front diaphragm attachment clips.
- 3 Note the switch position and wire run.
- 4 Withdraw the wires through the diaphragm hole.
- 5 Withdraw the switch.

### Refitting

- 6 Reverse 1 to 5.

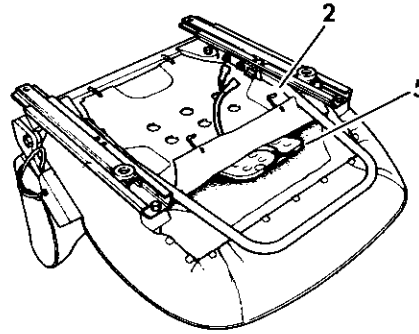

AB6 033

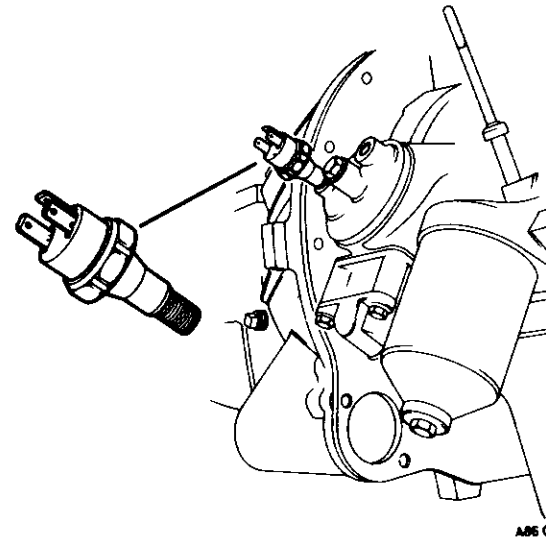

AB6 011

## DRIVER'S BELT SWITCH

Remove and refit 86.65.31

Passenger's belt switch —  
remove and refit 86.65.32

### Removing

- 1 Remove the driver's seat, see 76.70.04 or the passenger's seat, see 76.70.05.
- 2 Remove single bolt to release the integral buckle and switch unit.
- 3 Collect up the wavy washer, flange bush and distance piece.

### Refitting

- 4 Reverse 1 to 3.

## HEATED BACK LIGHT SWITCH

Remove and refit 86.65.36

### Removing

- 1 Remove the fascia switch panel, see 86.65.66.
- 2 Using a small screwdriver carefully prise off two Spire clips.
- 3 Remove the face panel and the switch identification strip assembly.
- 4 Push inwards two spring clips on the switch and withdraw the switch from the panel.

### Refitting

- 5 Reverse 1 to 4.

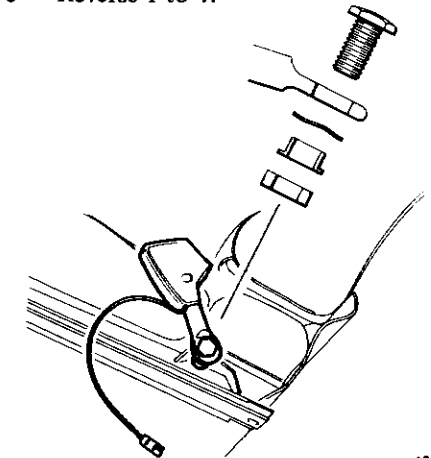

AB6 035

## OIL PRESSURE SWITCH – UK & Europe

Remove and refit 86.65.30

### Removing

- 1 Locate the switch on the right-hand side of the engine adjacent to the dipstick tube.
- 2 Disconnect the Lucar connector.
- 3 Using a spanner, unscrew the switch from the oil transfer adaptor.

### Refitting

- 4 Screw the switch into the oil transfer adaptor. The thread is tapered. Do not overtighten.
- 5 Connect the Lucar connector.

## OIL PRESSURE SWITCH – USA Specification Vehicles

Remove and refit 86.65.30

### Removing

- 1 Locate the switch on the right hand side of the engine adjacent to the dipstick.
- 2 *Normal vehicles only*— Disconnect one Lucar connector.
- 3 *Emission control—anti run on system vehicles only*— Disconnect three Lucar connectors.
- 4 Using a spanner, unscrew the switch from the oil transfer adaptor.

### Refitting

- 5 Screw the switch into the oil transfer adaptor. The thread is tapered. Do not overtighten.
- 6 *Normal vehicles only*— Connect one Lucar connector.
- 7 *Emission control—anti run on system vehicles only*— Connect three Lucar connectors as shown.

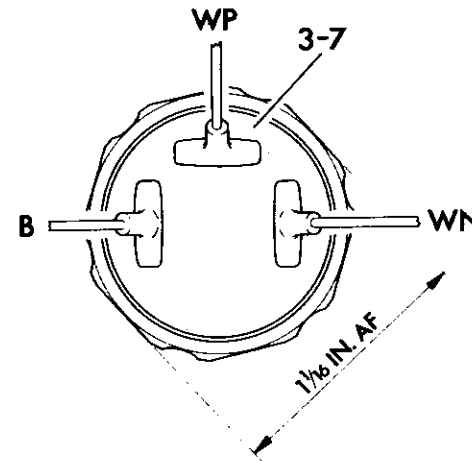

AB6 020

**HANDBRAKE SWITCH**

Remove and refit **86.65.45**

**Removing**

- 1 Remove the console assembly, see 76.25.01.
- 2 Pull apart the Velcro 'touch and close' fastener strips along the top edge of the hand brake gauntlet.
- 3 Remove the single Pozidriv screw and detach the switch.
- 4 Disconnect the Lucar connector.

**Refitting**

- 5 Reverse 1 to 4.

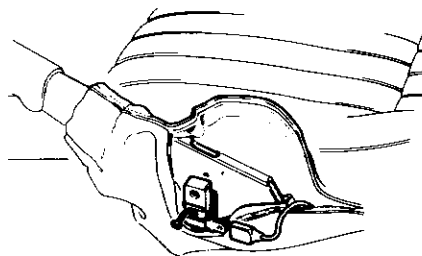

A 86 001

**BRAKE LINE FAILURE SWITCH**

Remove and refit **86.65.47**

**Removing**

- 1 Locate the brake line failure switch on the brake master cylinder.
- 2 Release the harness plug claws and disconnect the harness plug from the switch.
- 3 Using a spanner on the nylon switch body carefully unscrew the switch.

**Refitting**

- 4 Carefully screw the switch to the brake master cylinder. Do not overtighten. Torque load to only 15 lbf in (0,17 kgf m).
- 5 Connect the harness plug. The harness plug may be fitted either way round.

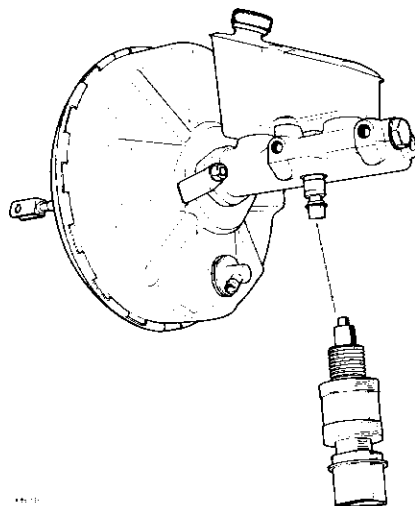
**HAZARD SWITCH**

Remove and refit **86.65.50**

**Removing**

- 1 Remove the fascia switch panel, see 86.65.66.
- 2 Using a small screwdriver carefully prise off two Spire clips.
- 3 Remove the face panel and the switch identification strip assembly.
- 4 Push inwards one plastic clip on the switch and withdraw the switch from the panel.

**Refitting**

- 5 Reverse 1 to 4. Insert the switch so that the 'symbol' is at the lower edge.
- NOTE:** The hazard warning light built into the switch has a bulb housed in the switch harness plug.

**STOP LAMP SWITCH**

Remove and refit **86.65.51**

**Removing**

- 1 Locate the switch adjacent to the brake pedal arm attachment to the brake servo.
- 2 Disconnect two Lucar connectors.
- 3 Slacken the large hexagon nut.
- 4 Push the brake pedal forward and remove the nut and washer/washers.  
**CAUTION:** Do not attempt to rotate the switch in the bracket as the switch has a locating flat.
- 5 Remove the switch from the bracket.

**Refitting**

- 6 Position the switch to the bracket.
- 7 Push the brake pedal forward and fit the washer/washers and nut finger-tight.
- 8 Tighten the nut lightly. Do not overtighten the nut on the plastic threads or the switch may be damaged.
- 9 Connect two Lucar connectors. The connectors may be fitted either way round.



## CHOKE SWITCH

Remove and refit 86.65.53

### Removing

- 1 Locate the choke switch attached to the choke cable adjacent to the hand knob.
- 2 Using a small screwdriver remove the small screw.
- 3 Slide the clip from the switch and remove both items.
- 4 Disconnect one Lucar connector.

### Refitting

- 5 Connect one Lucar connector.
- 6 Position the switch and clip over the reduced diameter of the cable. Slide the clip onto the switch.
- 7 Position the assembly so that the switch plunger is located in the hole provided in the outer cable housing. Secure with the small screw.

## CIGARETTE LIGHTER

Remove and refit 86.65.60

### Removing

- 1 Isolate the battery.
- 2 Pull out the centre console tray.
- 3 Withdraw the cigarette lighter heating unit.
- 4 Pull the purple wire 3 mm connector from the centre terminal.
- 5 Carefully insert a pair of long nosed pliers into the inner well to locate on the stronger cross piece as shown. Holding the outer well, unscrew the inner well from the outer well.
- 6 Remove the illumination ring.
- 7 Disconnect the black earth wire Lucar connector.
- 8 Disconnect the red/white wire single pin harness plug.
- 9 If necessary renew the bulb as follows: Squeeze the sides of the bulb cowl and withdraw. Unclip the bulb cowl from the bulb holder. Remove the bulb from the bayonet fitting.

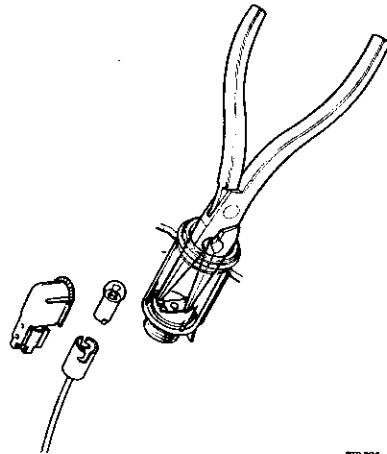

PI0 205

## STEERING COLUMN MULTI-PURPOSE SWITCH

Remove and refit 86.65.64

### Removing

- 1 Isolate the battery.
- 2 Unscrew two long Pozidriv screws and remove the nacelle upper and lower halves.  
**NOTE:** The screws have a long threaded length of approximately 20 mm. A long 'unscrew time' should be expected.
- 3 Remove the steering wheel, see 57.60.01.
- 4 Note the switch harness wire runs.
- 5 Remove the Insuloid harness clip securing the switch harnesses to the fascia rail support strut. The clip is released by squeezing the projection as shown.
- 6 Disconnect two harness plugs.
- 7 Slacken the switch clamp screw.
- 8 Withdraw the switch complete with its harnesses from the column.

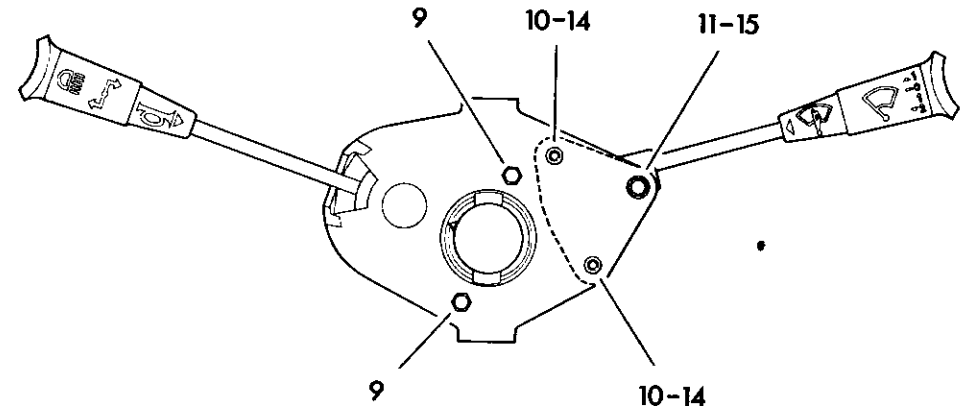

A 86 165

### Individual switch renew

The multi-purpose switch is initially fitted as a complete unit. In service either half of the switch may be renewed as follows:

- 9 Do not slacken or remove two hexagon headed screws.
- 10 Drill out two rivets.
- 11 Remove one hexagon headed screw and washer.
- 12 Discard the defective switch.
- 13 Position the new switch.
- 14 Fit two bolts and nuts supplied with the new switch.
- 15 Fit one hexagon headed screw and washer. Do not fully tighten as the screw head is required to move with the switch arm.

*continued*

### Refitting

- 10 Reverse 1 to 9. Fit the cigarette lighter so that the bulb cowl is suitably positioned.

**Refitting**

- 16 Insert the switch harnesses into position. Position the switch to the column with the switch tongue located into the outer tube assembly slot.
- 17 Push the switch against the outer tube assembly and tighten the switch clamp screw.
- 18 Position the switch harness wire runs as noted at operation 4 above.
- 19 Connect two harness plugs.
- 20 Fit the Insuloid harness clip to secure the switch harnesses to the fascia rail support strut.
- 21 Fit the steering wheel, see 57.60.01.  
**NOTE:** The turn signal cancelling collar must be correctly aligned at this stage. Refer to 57.60.01.
- 22 Position the nacelle upper and lower halves. Secure with two long Pozidriv screws.
- 23 Connect the battery.

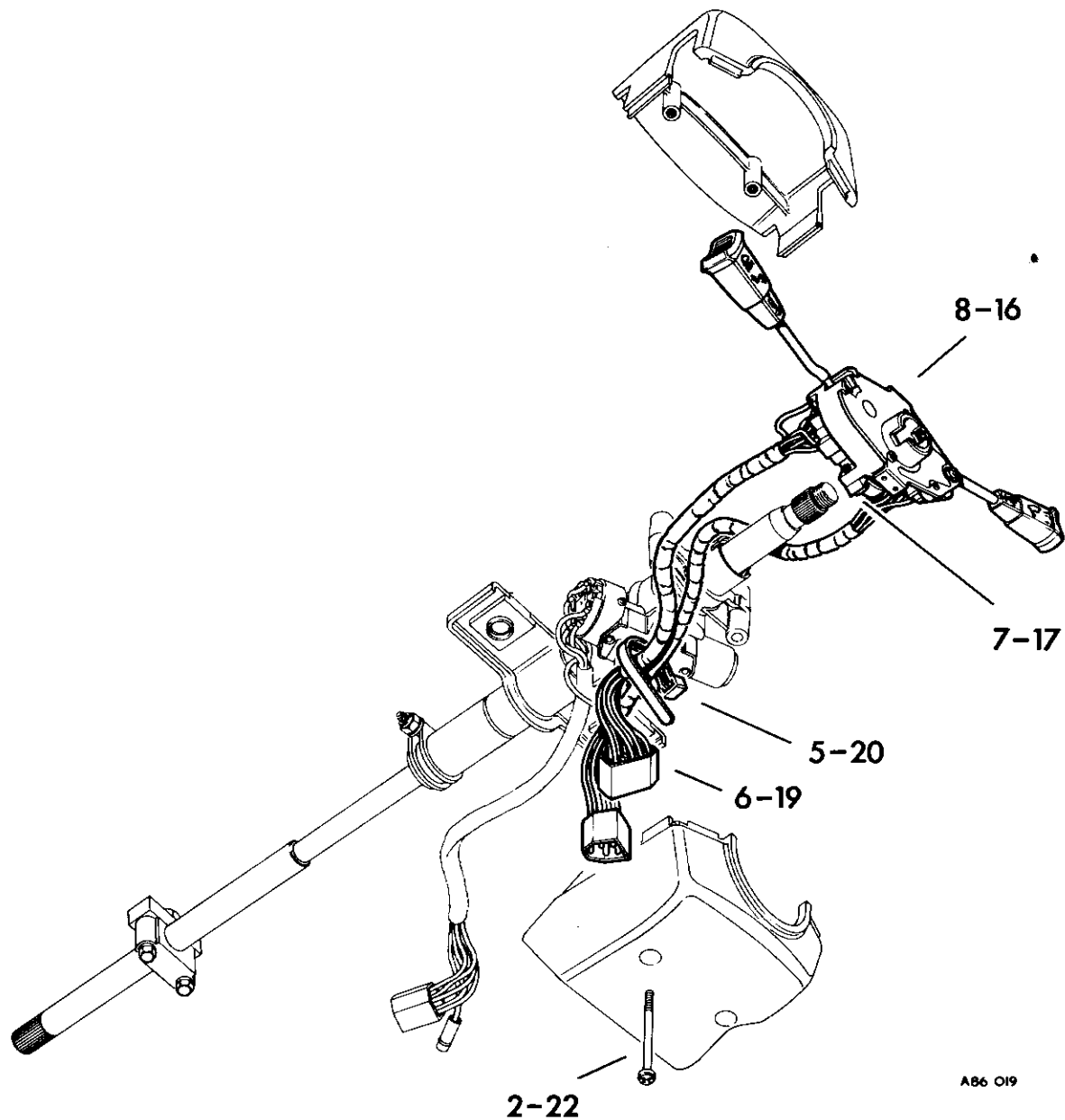

## REAR FOG LAMP SWITCH

Remove and refit 86.65.65

### When fitted

#### Removing

- 1 Remove the fascia switch panel, see 86.65.66.
- 2 Using a small screwdriver carefully prise off two Spire clips.
- 3 Remove the face panel and the switch identification strip assembly.
- 4 Push inwards two spring clips on the switch and withdraw the switch from the panel.

#### Refitting

- 5 Reverse 1 to 4.

## FASCIA SWITCH PANEL

Remove and refit 86.65.66

#### Removing

- 1 Remove two Pozidriv screws and washers. Withdraw the fascia switch panel.
- 2 Pull out two switch identification strip bulb holders.
- 3 Disconnect all switch harness plugs.
- 4 Remove the fascia switch panel from the vehicle.

#### Refitting

- 5 Reverse 1 to 4.

## FUSE

Remove and refit 86.70.02

### Fuse box

#### Removing

- 1 Open the cubby box lid.
- 2 Remove two Pozidriv screws. Withdraw the lower panel to obtain access to the component mounting plate.
- 3 Locate the fuse box attached to the component mounting plate.
- 4 Pull off the plastic cover.
- 5 Identify the defective fuse.
- 6 Carefully lever the fuse from the contacts.

#### Refitting

- 7 Reverse 1 to 6.

### In line

#### Removing

- 1 Open the cubby box lid.
- 2 Remove two Pozidriv screws. Withdraw the lower panel to obtain access to the component mounting plate.
- 3 Locate the two in line fuses using the appropriate illustration.
- 4 Identify the two in line fuses as follows:  
Front parking lamp and cockpit illuminations to red/green and red wires. Heated backlight to white and white/black wires.
- 5 Release the bayonet type fitting to separate the two parts of the fuse holder.
- 6 Remove the fuse.

#### Refitting

- 7 Reverse 1 to 6.

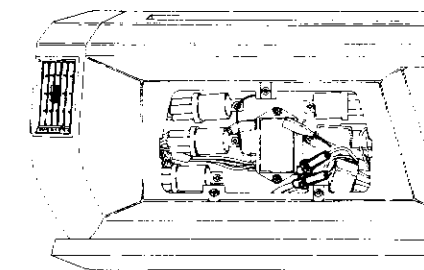
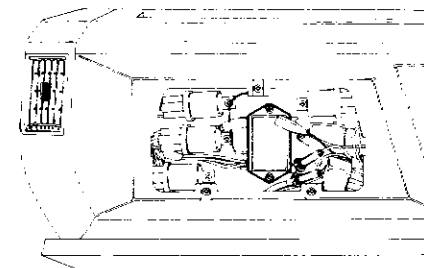

**BATTERY CONDITION INDICATION**

<b>Data</b>		<b>88.10.00</b>
Manufacturer .....	Smith's	
Type .....	Bi-metal resistance	
Smith's part number .....	BV 8115/00	
Triumph part number .....	UKC 0512	
<b>Illumination</b> .....	Remote by instrument panel illumination	

**Description**

The Smith's 'bi-metal resistance' battery condition indicator measures the system voltage. Instrument response is slow to damp out short period variations. The indicator produces no radio interference and no suppression equipment is required.

The battery condition indicator contains a bi-metal strip surrounded by a heater series winding. Current flow through the series winding heats the bi-metal strip which consequently distorts. The pointer is suspended between the moving end of the bi-metal strip and a spring blade. This arrangement causes the pointer to take up a position over the scale that is related to current flow through the indicator. Current flow through the indicator is related to system voltage.

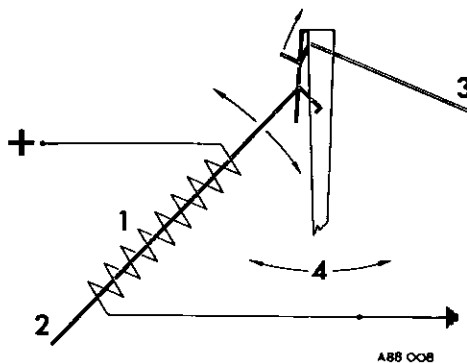

- † Supply voltage
- 1 Heater series winding
- 2 Bimetal strip
- 3 Spring blade
- 4 Pointer

**BATTERY CONDITION INDICATOR**

**Remove and refit** **88.10.07**

**Removing**

- 1 Remove the lens, see 88.20.17.
- 2 Lift away the face panel.
- 3 Remove one Pozidriv screw.
- 4 Carefully withdraw the battery condition indicator.

**Refitting**

- 5 Reverse 1 to 4.

**CLOCK**

<b>Data</b>		
Manufacturer .....	Smith's--made in France	
Type .....	Transistor	
Smith's part number .....	CTJ 3702/00	
Triumph part number .....	UKC 2408	

**CLOCK**

**Adjust** **88.15.04**

Set the hands to the correct time—  
Locate the adjustment knob below the fascia and to the left of the speedometer trip reset knob. Push the clock adjustment knob upwards and rotate to set the hands.

Regulate the clock—

The clock is precision regulated during manufacture and no further adjustment is possible in service. If the clock is gaining or losing less than five minutes per week the clock should be periodically reset to the correct time as detailed above. If the clock is gaining or losing more than five minutes per week the clock should be replaced.

**CLOCK**

**Remove and refit** **88.15.07**

**Removing**

- 1 Remove the lens, see 88.20.17.
- 2 Lift away the face panel.
- 3 Unscrew the knurled nut. Withdraw the clock cable.
- 4 Remove two Pozidriv screws.
- 5 Withdraw the clock.

**Refitting**

- 6 Reverse 1 to 5.

## INSTRUMENT PANEL

### Description 88.20.00

The instrument panel is an independent unit which contains a set of instruments and a comprehensive set of warning lights. These are enclosed in a plastic housing. The exposed side of the instrument panel is finished with a face panel and a one-piece curved lens produced from ICI Acrylic. The individual instruments therefore require no bodies or glasses.

Electrical connections from the vehicle harness to the printed circuit attached to the concealed side of the instrument panel is by two multi-contact harness plugs.

The mechanism of the individual instruments are screw mounted into the housing. Electrical input to the instruments is via the instrument pillars. The electrical path from the printed circuit to the instrument pillars is by metal clips screwed down against exposed sections of the printed circuit. This design allows any instrument to be removed and refitted without making any conscious electrical connections.

The warning light bulbs are retained in bulb holders which are fitted into the concealed side of the instrument panel by bayonet fittings. The warning light annotated lens blocks are positioned by housing dowels and are retained by being sandwiched between the housing and the face panel. The warning light electrical connections are made automatically by two bulb holder strips making direct contact against exposed sections of the printed circuit.

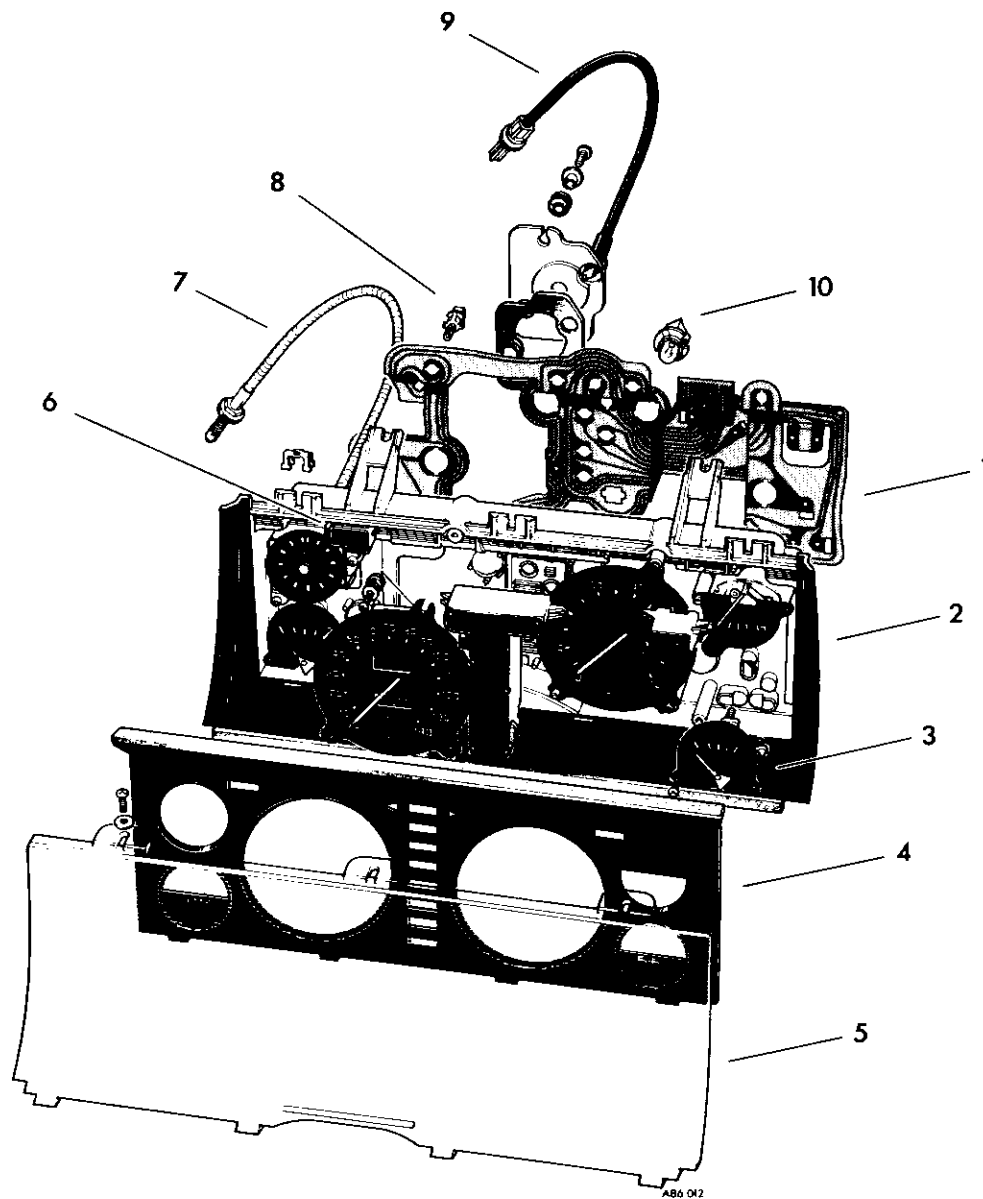

- 1 Printed circuit
- 2 Housing
- 3 Instrument
- 4 Face panel
- 5 Lens
- 6 Annotated lens block
- 7 Clock cable
- 8 Warning light
- 9 Speedometer trip reset cable
- 10 Instrument illumination

## INSTRUMENT PANEL

Remove and refit

88.20.01

## Removing

- 1 Remove the fascia centre grille, see 76.55.14.
- 2 Remove the fascia instrument cowl, see 76.46.17.
- 3 Unscrew two long Pozidriv screws and remove the nacelle upper and lower halves.  
**NOTE:** The screws have a long threaded length of approximately 20 mm. A long 'unscrew time' should be expected.
- 4 Slacken the speedometer trip reset cable knurled nut. Withdraw the cable from the bracket slot.
- 5 Slacken the clock cable knurled nut. Withdraw the cable from the bracket slot.
- 6 Depress the lever to release the catch from the annular groove in the boss. Pull the speedometer cable from the instrument.
- 7 Remove two upper Pozidriv screws and washers.
- 8 Remove two lower Pozidriv screws and washers.
- 9 Withdraw the instrument panel slightly.
- 10 Disconnect two harness multi-contact plugs.
- 11 Remove the instrument panel from the vehicle.

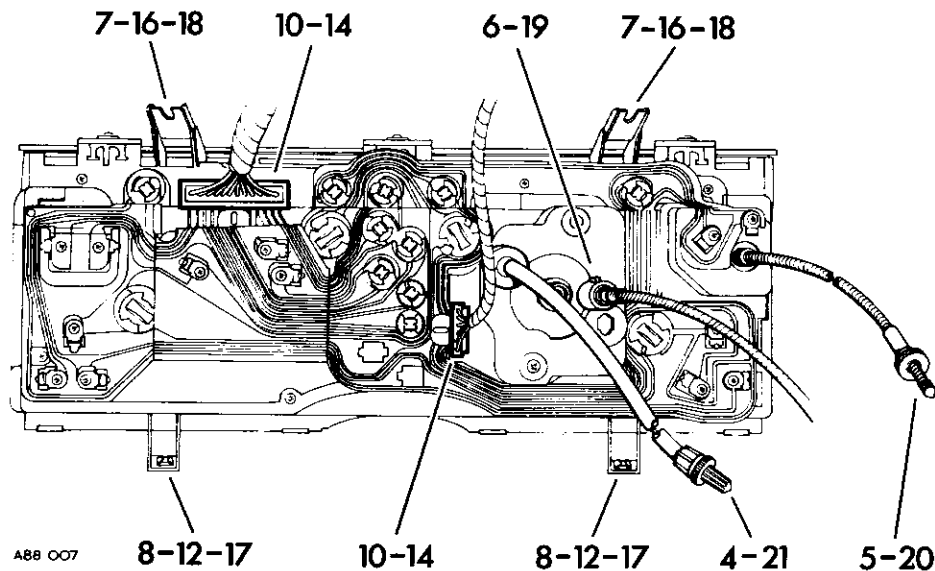
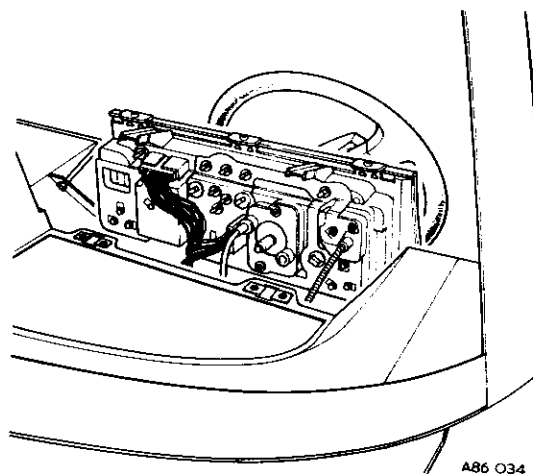

## Refitting

- 12 Ensure that two lower Spire nuts are correctly fitted.
- 13 Position the instrument panel with the clock cable and the speedometer trip reset cable inserted either side of the fascia rail support strut and harnesses.
- 14 Connect two harness multi-contact plugs.
- 15 Insert the instrument panel to its correct position.
- 16 To help establish the correct position, fit two upper Pozidriv screws and washers finger-tight.
- 17 Fit two lower Pozidriv screws and washers.
- 18 Tighten two upper Pozidriv screws and washers.
- 19 Push the speedometer cable onto the instrument. Ensure that the catch engages into the annular groove in the boss.
- 20 Insert the clock cable into the appropriate bracket slot. Hand tighten the knurled nut.
- 21 Insert the speedometer trip reset cable into the appropriate bracket slot. Hand tighten the knurled nut.
- 22 Position the nacelle upper and lower halves. Secure with two long Pozidriv screws.
- 23 Fit the fascia instrument cowl, see 76.46.17.
- 24 Fit the fascia centre grille, see 76.55.14.

## INSTRUMENT PANEL

**Lens – remove and refit 88.20.17**

### Removing

- 1 Remove the fascia centre grille, see 76.55.14.
- 2 Remove the fascia instrument cowl, see 76.46.17.
- 3 Remove three Pozidriv screws and washers.
- 4 Carefully slide the lens upwards following the path of its natural arc.

### Refitting

- 5 Reverse 1 to 4. If difficulty is experienced to engage the four lens tongues, slacken two lower Pozidriv screws and slightly reposition the instrument panel.

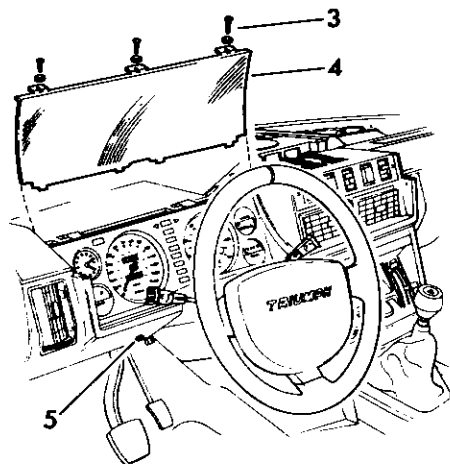

488 003

## INSTRUMENT PANEL

**Printed circuit – remove and refit 88.20.19**

### Removing

- 1 Remove the instrument panel, see 88.20.01.
- 2 Remove a number of small Pozidriv screws.
- 3 Lift out a number of contact clips.
- 4 Rotate four large bulb holders anti-clockwise and lift from the bayonet fittings.
- 5 Rotate a number of small bulb holders anti-clockwise and lift from the bayonet fittings.
- 6 Use a small screwdriver to carefully prise up two plastic press clips. Take care not to damage the printed circuit.
- 7 Release any sticky tape.
- 8 Lift away the printed circuit.

### Refitting

- 9 Reverse 1 to 8.

## FUEL AND TEMPERATURE INDICATION

### Data

88.25.00

### Fuel indicator

Manufacturer .....	Smith's
Type .....	Air cored
Smith's part number .....	ACF 8103/00
Triumph part number .....	UKC 0511

Body .....	None—assembled into instrument panel
Illumination .....	Remote by instrument panel illumination

### Fuel tank unit

Manufacturer .....	Smith's
Smith's part number .....	TBS 5232/000EC
Triumph part number .....	TKC 0147

### Temperature indicator

Manufacturer .....	Smith's
Type .....	Air cored
Smith's part number .....	ACT 8102/00
Triumph part number .....	UKC 0510

Body .....	None—assembled into instrument panel
Illumination .....	Remote by instrument panel illumination

### Temperature transmitter

Manufacturer .....	Smith's
Type .....	Semi-conductor
Smith's part number .....	TT 4803/00A
Triumph part number .....	150843

Colour code .....	Black
Indication range .....	50 to 140 deg. centigrade
Thread .....	½ in—18 UNF

## FUEL AND TEMPERATURE INDICATION

### Description 88.25.00

The Smith's 'air cored' indication system is suitable for rugged environments and able to withstand high levels of vibration. Instrument response is rapid. The system is self-compensating for variation in voltage supply and no voltage stabilizer is required. The system produces no radio interference and no suppression equipment is required.

The 'air cored' indicator consists of three individual coil windings positioned relative to each other as shown. A central shaft carries a magnet bar which is free to swing in the area enclosed by the coils. The end of the shaft carries the pointer.

The magnetic field direction produced by any one coil is fixed. The magnetic field strength produced by any one coil may be varied by adjusting the current through the appropriate coil. The final magnetic field direction is the resultant of the currents through all three coils.

The design is that two of the coils

receive a constant current. The third coil receives a current managed by a variable resistor which is the appropriate system sensor. The sensor therefore controls the final magnetic field direction. The magnet bar aligns itself with this magnetic field direction and the pointer is positioned to indicate the correct dial reading.

Switch off - when the circuit supply is switched off a small permanent magnet located in the assembly influences the magnet bar and the pointer returns to the zero position. The effect of this 'pull off' magnet is allowed for when calibrating the instrument during manufacture.

The circuit diagram for the fuel indication system and the temperature indication system is shown. Coils 'A' and 'B' receive an almost constant current. In this circuit the current through coils 'A' and 'B' will vary but to a small amount compared to the variation through coil 'C'. Coil 'C' receives a current managed by the fuel tank unit or the temperature transmitter. A ballast resistor and calibration resistor are included in the circuit as shown.

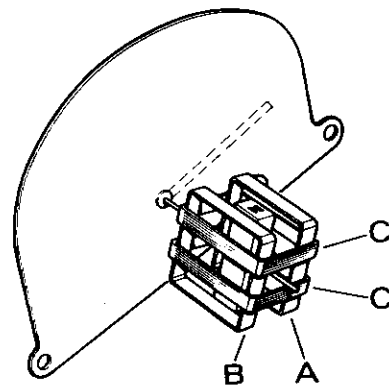

888 005

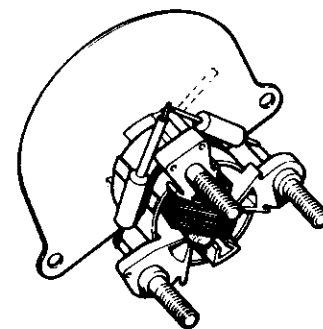

888 004

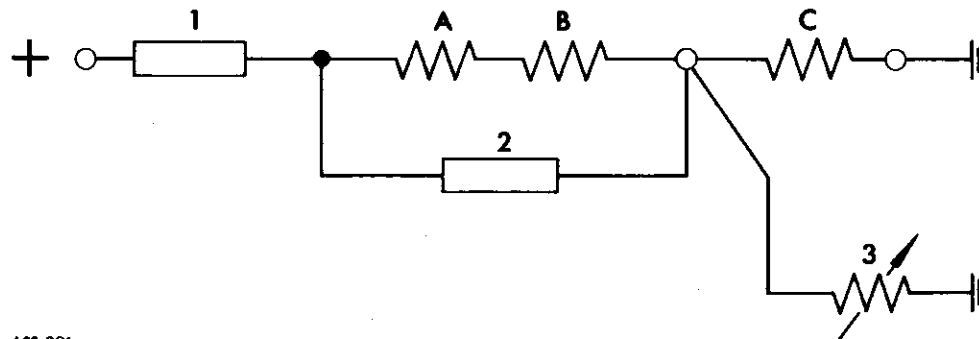

888 006

- 1 Ballast resistor
- 2 Calibration resistor
- A Coil 'A'
- B Coil 'B'
- C Coil 'C'
- 3 System sensor



## TEMPERATURE INDICATION

### TEMPERATURE INDICATOR Remove and refit 88.25.14

#### Removing

- 1 Remove the lens, see 88.20.17.
- 2 Lift away the face panel.
- 3 Remove one Pozidriv screw.
- 4 Carefully withdraw the temperature indicator.

#### Refitting

- 5 Reverse 1 to 4.

### TEMPERATURE TRANSMITTER Remove and refit 88.25.20

#### Removing

- 1 Drain part of the coolant, see 26.10.01.
- 2 Locate the transmitter on the inlet manifold.
- 3 Disconnect the Lucar connector.
- 4 Unscrew the transmitter from the inlet manifold.

#### Refitting

- 5 Reverse 1 to 4. Fit a new sealing washer if available.

## FUEL INDICATION

### FUEL INDICATOR Remove and refit 88.25.26

#### Removing

- 1 Remove the lens, see 88.20.17.
- 2 Lift away the face panel.
- 3 Remove one Pozidriv screw.
- 4 Carefully withdraw the fuel indicator.

#### Refitting

- 5 Reverse 1 to 4.

### FUEL TANK UNIT Remove and refit 88.25.32

#### Removing

- 1 Drive the vehicle onto a ramp.
- 2 Estimate the quantity of fuel in the fuel tank.
- 3 Provide a suitable container to receive the quantity.
- 4 Raise the ramp.
- 5 Disconnect three Lucar connectors.
- 6 Prepare for fuel spillage. Pull off the rubber fuel outlet pipe and drain the tank contents into the container.
- 7 Release the locking ring by tapping anti-clockwise. Remove the locking ring.  
**NOTE:** This operation may be facilitated by employing a service tool – Churchill number 18G 1001.
- 8 Carefully withdraw the tank unit.
- 9 Remove the sealing washer.

#### Refitting

- 10 Reverse 1 to 9. Fit a new sealing washer if available. Connect the Lucar connectors as follows:  
Green/black wire to terminal T.  
Green/orange wire to terminal W.  
Black wire to earth terminal.

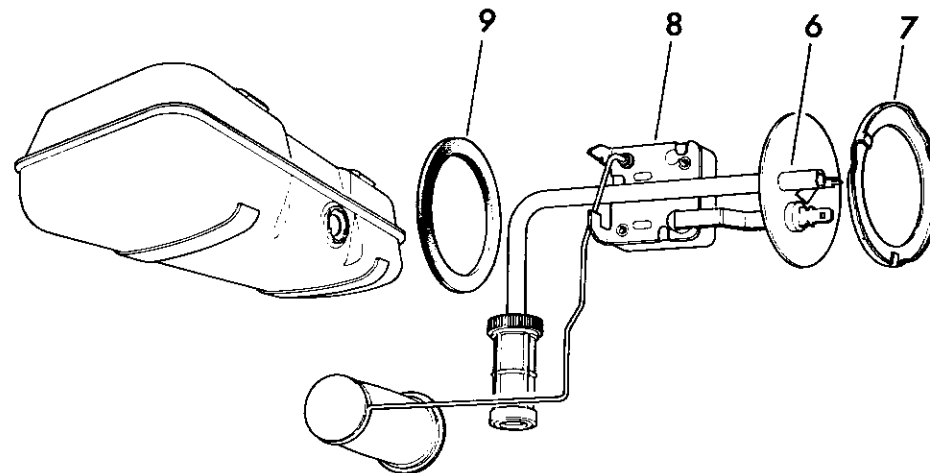

**SPEEDOMETER**

Remove and refit 88.30.01

**Removing**

- 1 Remove the lens, see 88.20.17.
- 2 Lift away the face panel.
- 3 Depress the lever to release the catch from the annular groove in the boss. Pull the speedometer cable from the instrument.
- 4 Remove three Pozidriv screws.
- 5 Withdraw the speedometer.

**Refitting**

- 6 To assist engagement of the speedometer trip reset cable rotate the control to pre-set the alignment.
- 7 Insert the speedometer.
- 8 Fit three Pozidriv screws.
- 9 Push the speedometer cable onto the instrument. Ensure that the catch engages into the annular groove in the boss.
- 10 Position the face panel.
- 11 Fit the lens, see 88.20.17.

**SPEEDOMETER**

Trip reset cable — remove and refit 88.30.02

**Removing**

- 1 Remove the speedometer, see 88.30.01.
- 2 Note the run of the trip reset cable.
- 3 Slacken the trip reset cable knurled nut. Withdraw the cable from the bracket slot.
- 4 To assist withdrawal of the trip reset cable rotate the control to pre-set the alignment.
- 5 Using a small screwdriver release the trip reset cable claws. Withdraw the trip reset cable attachment from the instrument panel housing.

**Refitting**

- 6 To assist insertion of the trip reset cable rotate the control to pre-set the alignment.
- 7 Insert the trip reset cable attachment into the instrument panel housing. Ensure that the claws engage correctly.
- 8 Ensure that the trip reset cable run is as noted at operation 2 above.
- 9 Insert the trip reset cable into the bracket slot. Hand tighten the knurled nut.
- 10 Fit the speedometer, see 88.30.01.



ABB 002

**TACHOMETER**

Remove and refit 88.30.21

**Removing**

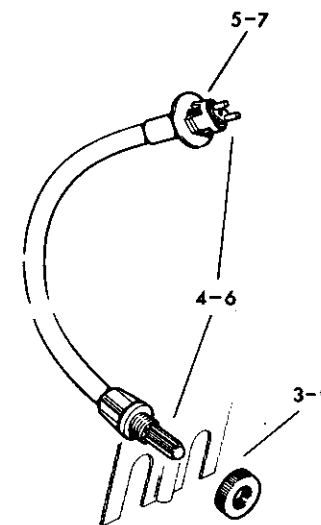
- 1 Remove the lens, see 88.20.17.
- 2 Lift away the face panel.
- 3 Remove three Pozidriv screws.
- 4 Carefully withdraw the tachometer.

**Refitting**

- 5 Reverse 1 to 4.

## SERVICE TOOLS

The following tool list is divided into two sections: 'New Tools' that have been specially designed for use on the Triumph TR7, and 'Existing Tools' that may already be in the possession of Distributors and Dealers, and are suitable for the Triumph TR7.

All service tools mentioned in this Manual must be obtained direct from the manufacturers:  
Messrs. V. L. Churchill & Co. Ltd.  
P.O. Box No. 3  
London Road  
Daventry, Northants.

NEW TOOLS		EXISTING TOOLS	
Tool No.	Description	Tool No.	Description
18G 47 BP	Adaptor set – remover/replacer – mainshaft bearing and speedometer gear.	S 357A	Plug spanners
18G 1198A	Adaptor sleeve (use with existing tool S 145C) – replacer – gearbox mainshaft circlip.	S 60A	Valve guide remover/replacer
S 356C	Hub remover (includes S 356C/5) see note below.	S60A-2A	Valve guide remover/replacer adaptor set.
S 356C/5	Retaining nuts for S 356A and B – hub remover see note below.	S60A-8	Valve guide replacer adaptor.
RTR 359	Front suspension unit closure nut wrench.	S 348	Water pump overhaul kit.
ST 1136	Clutch withdrawal pivot spanner. See note below.	S 349	Distributor remove/refit spanner.
RTR 360	Front suspension upper swivel dished washer retaining spanner.	S 350	Cylinder head stud remover/replacer.
18G 1261	Steering rack pinion retaining nut.	S 352	Valve spring adaptor.
	<b>NOTE:</b> Distributors and Dealers who already hold existing tools S 356A or S 356B – hub remover, can obtain modification details to bring them to condition 'C' and then need only order S 356C/5 – retaining nuts. Also, note that tool ST 1136 is a 'snap on' supply item.	S 353	Carburettor adjusting tool.
		S 4235A-10	Water pump assembly remover.
		18G 1199	Gearbox mainshaft circlip (S 144A)
		S 145	Gearbox mainshaft circlip replacer.
		18G 284 AAA	Input shaft remover.
		(S 4235A-2)	
		S 314	Mainshaft ball bearing replacer.
		8G 47 BD	Differential bearing adaptor remover.
		18G 134 DH	Differential bearing adaptor replacer.
		S 101	Differential case spreader.
		18G 191	Bevel pinion setting gauge.
		18G 191M	Dummy pinion.
		S 304	Rear hub bearing replacer.
		RG 421	} Propeller shaft flange wrench.
		or	
		18G 1205	
		18G 106	Valve spring compressor.
		S 4221A-17	Pinion head bearing remover/replacer adaptor.
		S 4235A-1	Axle shaft remover
		P 5045	Front suspension spring compressor.
		47 (S4221A)	Hand press.
		18G 134	Basic handle.
		(550)	
		3072	Impact remover.

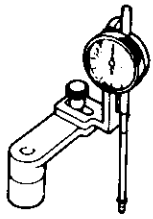

18G.191

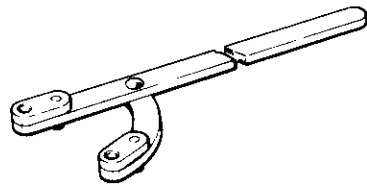

18G.1205

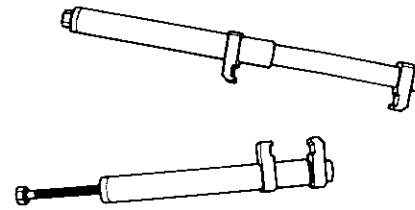

P.5045

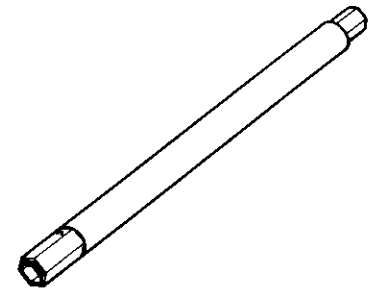

S.357A Plug spanner

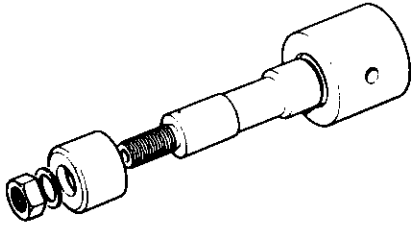

18G.191M

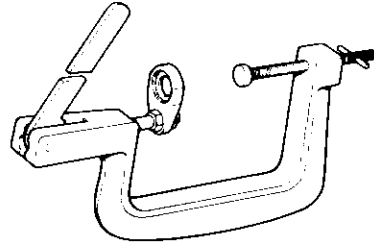

18G.106

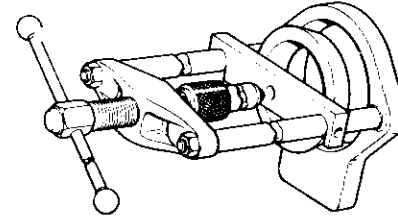

47

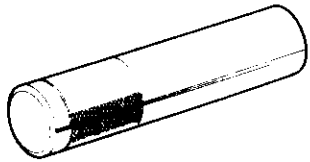

S.304

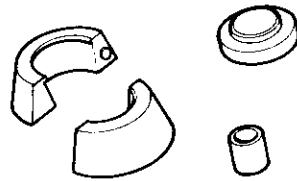

S.4221A-17

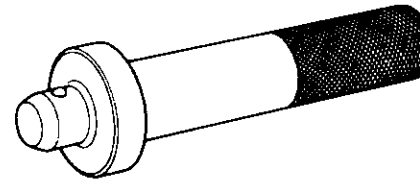

18G.134  
(550)

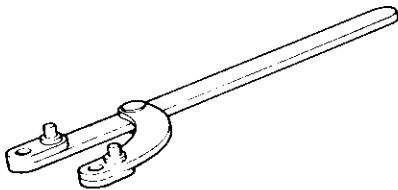

RG.421

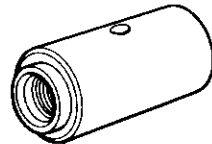

S.4235A-1

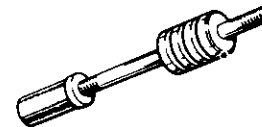

3072

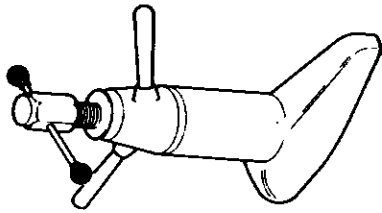

60A

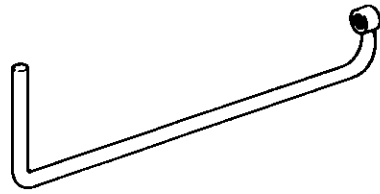

S.349

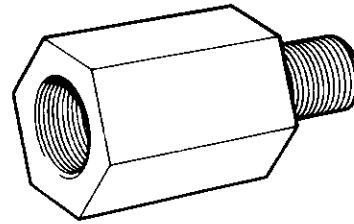

S.4235A-10

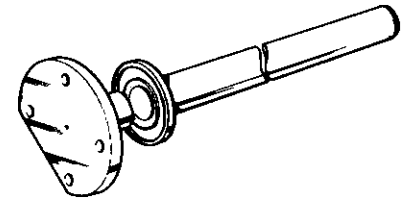

S.314

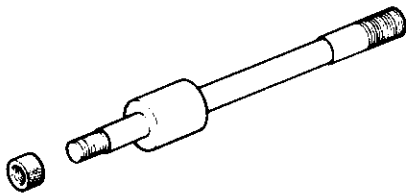

S.60A-2A

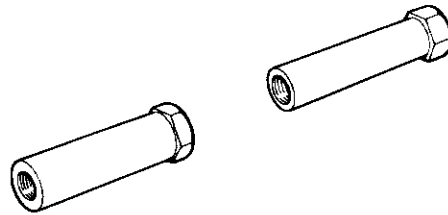

S.350

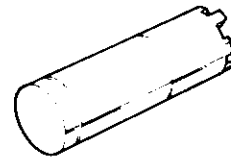

18G.1199  
(S.144A)

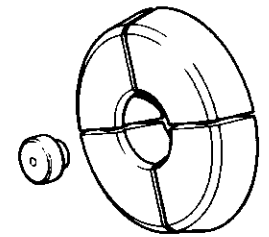

18G.47BD

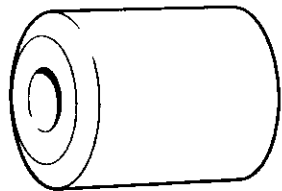

S.60A-8

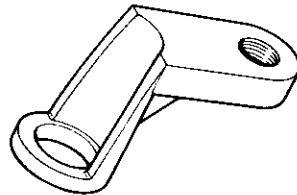

S.352

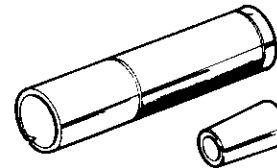

S.145

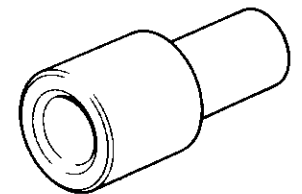

18G.134DH

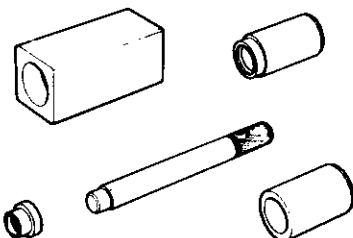

S.348

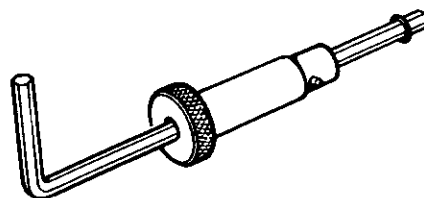

S.353

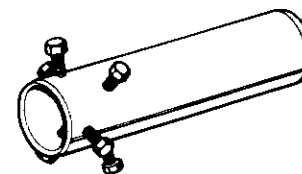

18G.284AAA  
(S.4235A-2)

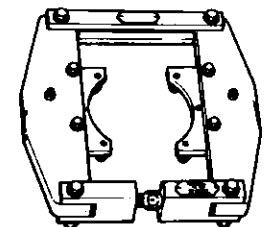

S.101